

# Hawkeye®<sup>®</sup>, Patriot MY 2017 Installation Manual

*P/N 016-0171-645 Rev. B 04/17*

*E29396*

## ***Disclaimer***

---

While every effort has been made to ensure the accuracy of this document, Raven Industries assumes no responsibility for omissions and errors. Nor is any liability assumed for damages resulting from the use of information contained herein.

Raven Industries shall not be responsible or liable for incidental or consequential damages or a loss of anticipated benefits or profits, work stoppage or loss, or impairment of data arising out of the use, or inability to use, this system or any of its components. Raven Industries shall not be held responsible for any modifications or repairs made outside our facilities, nor damages resulting from inadequate maintenance of this system.

As with all wireless and satellite signals, several factors may affect the availability and accuracy of wireless and satellite navigation and correction services (e.g. GPS, GNSS, SBAS, etc.). Therefore, Raven Industries cannot guarantee the accuracy, integrity, continuity, or availability of these services and cannot guarantee the ability to use Raven systems, or products used as components of systems, which rely upon the reception of these signals or availability of these services. Raven Industries accepts no responsibility for the use of any of these signals or services for other than the stated purpose.

---

<b>Chapter 1</b>	<b><i>Important Safety Information</i></b> .....	<b>1</b>
	Instructions for Wire Routing .....	2
	Instructions for Hose Routing .....	3
<b>Chapter 2</b>	<b><i>Introduction</i></b> .....	<b>7</b>
	Required Components .....	7
	Tools and Materials Needed .....	7
	Point of Reference .....	8
	Kit Contents .....	8
	Updates .....	11
<b>Chapter 3</b>	<b><i>Installation Preparation</i></b> .....	<b>13</b>
<b>Chapter 4</b>	<b><i>Boom Installation</i></b> .....	<b>15</b>
	Hawkeye Nozzle Control Valve Installation .....	15
	Best Practices and Recommendations .....	15
	Boom Cable Routing and Connection .....	16
	Best Practices and Recommendations .....	16
	Secondary Boom Cable Routing and Connections .....	17
	Primary Boom Cable Routing and Connections .....	18
	System Diagram .....	20
<b>Chapter 5</b>	<b><i>Hawkeye® Adapter Harness Installation</i></b> .....	<b>21</b>
	Adapter Harness Installation .....	21
<b>Chapter A</b>	<b><i>Cable and Connector Maintenance</i></b> .....	<b>25</b>
	Power and ECU Harness Maintenance .....	25
	Hawkeye Boom Harness Connector Maintenance .....	25



---

# CHAPTER

# 1

# IMPORTANT SAFETY INFORMATION

---

## NOTICE

Read this manual and all operation and safety instructions included with the implement and/or controller carefully before installing the Hawkeye® system.

- Follow all safety information presented within this manual.
- If you require assistance with any portion of the installation or service of Case IH equipment, contact a local Case IH dealer for support.
- Follow all safety labels affixed to system components. Be sure to keep safety labels in good condition and replace any missing or damaged labels. To obtain replacements for missing or damaged safety labels, contact a local Case IH dealer.

When operating the machine, observe the following safety measures:

- Be alert and aware of surroundings.
- Do not operate agricultural equipment while under the influence of alcohol or an illegal substance.
- Remain in the operator's position in the machine at all times when equipment is engaged. Disable system functions or features when exiting from the operator's seat and machine.
- Do not drive the machine with equipment enabled on any public road.
- Determine and remain a safe working distance from other individuals. The operator is responsible for disabling Hawkeye when the safe working distance has been diminished.
- Ensure Hawkeye is disabled prior to starting any maintenance work on the system or the implement.

## DANGER

### AGRICULTURAL CHEMICAL SAFETY

- Thoroughly bleed pressure from chemical lines and rinse the system with clean water prior to installing or servicing fittings, hoses, valves, or nozzles in the application system.
- Always follow safety labels and instructions provided by the chemical manufacturer or supplier.
- Always wear appropriate personal protective equipment as recommended by the chemical and/or equipment manufacturer.
- Fill, flush, calibrate, and decontaminate chemical application systems in an area where runoff will not reach ponds, lakes, streams, livestock areas, gardens, or populated areas.
- Avoid inhaling chemical dust or spray particulate and avoid direct contact with any agricultural chemicals. Seek immediate medical attention if symptoms of illness occur during, or soon after, use of agricultural chemicals, products, or equipment.
- After handling or applying agricultural chemicals:

- Thoroughly wash hands and face after using agricultural chemicals and before eating, drinking, or using the rest room.
- Thoroughly flush or rinse equipment used to mix, transfer, or apply chemicals with water after use or before servicing any component of the application system.
- Follow all federal, state, and local regulations regarding the handling, use, and disposal of agricultural chemicals, products, and containers. Triple-rinse and puncture or crush empty containers before disposing of them properly. Contact a local environmental agency or recycling center for additional information.

## CAUTION

### ELECTRICAL SAFETY

- Always verify that the power leads are connected to the correct polarity as marked. Reversing the power leads could cause severe damage to the equipment.
- Disconnect the Hawkeye system ECUs and control console before jump starting the vehicle or welding on any part of the implement or machine.

---

## INSTRUCTIONS FOR WIRE ROUTING

The word “harness” is used to mean all electrical leads and cables, bundled and unbundled. When installing harness, secure it at least every 30 cm (12in) to the frame. Follow existing harness as much as possible and use these guidelines:

Harness should not contact or be attached to:

- Lines and hoses with high vibration forces or pressure spikes
- Lines and hoses carrying hot fluids beyond harness component specifications

Avoid contact with any sharp edge or abrading surfaces such as, but not limited to:

- Sheared or flame cut edges
- Edges of machined surfaces
- Fastener threads or cap screw heads
- Ends of adjustable hose clamps
- Wire exiting conduit without protection, either ends or side of conduit
- Hose and tube fittings

Routing should not allow harnesses to:

- Hang below the unit
- Have the potential to become damaged due to exposure to the exterior environment. (i.e. tree limbs, debris, attachments)
- Be placed in areas of or in contact with machine components which develop temperatures higher than the temperature rating of harness components
- Wiring should be protected or shielded if it needs to route near hot temperatures beyond harness component specifications

Harnessing should not have sharp bends

Allow sufficient clearance from machine component operational zones such as:

- Drive shafts, universal joints and hitches (i.e. 3-point hitch)
- Pulleys, gears, sprockets
- Deflection and backlash of belts and chains
- Adjustment zones of adjustable brackets
- Changes of position in steering and suspension systems
- Moving linkages, cylinders, articulation joints, attachments
- Ground engaging components

For harness sections that move during machine operation:

- Allow sufficient length for free movement without interference to prevent: pulling, pinching, catching or rubbing, especially in articulation and pivot points
- Clamp harnesses securely to force controlled movement to occur in the desired harness section
- Avoid sharp twisting or flexing of harnesses in short distances
- Connectors and splices should not be located in harness sections that move

Protect harnesses from:

- Foreign objects such as rocks that may fall or be thrown by the unit
- Buildup of dirt, mud, snow, ice, submersion in water and oil
- Tree limbs, brush and debris
- Damage where service personnel or operators might step or use as a grab bar
- Damage when passing through metal structures

**IMPORTANT:** Avoid directly spraying electrical components and connections with high pressure water. High pressure water sprays can penetrate seals and cause electrical components to corrode or otherwise become damaged. When performing maintenance:

- Inspect all electrical components and connections for damage or corrosion. Repair or replace components, connections, or cable as necessary.
- Ensure connections are clean, dry, and not damaged. Repair or replace components, connections, or cable as necessary.
- Clean components or connections using low pressure water, pressurized air, or an aerosol electrical component cleaning agent.
- Remove visible surface water from components, connections, or seals using pressurized air or an aerosol electrical component cleaning agent. allow components to dry completely before reconnecting cables.

---

## INSTRUCTIONS FOR HOSE ROUTING

The word "hose" is used to mean all flexible fluid carrying components. Follow existing hoses as much as possible and use these guidelines:

Hoses should not contact or be attached to:

- Components with high vibration forces
- Components carrying hot fluids beyond component specifications

Avoid contact with any sharp edge or abrading surfaces such as, but not limited to:

- Sheared or flame cut edges
- Edges of machined surfaces
- Fastener threads or cap screw heads
- Ends of adjustable hose clamps

Routing should not allow hoses to:

- Hang below the unit
- Have the potential to become damaged due to exposure to the exterior environment. (i.e. tree limbs, debris, attachments)
- Be placed in areas of or in contact with machine components which develop temperatures higher than the temperature rating of hose components
- Hoses should be protected or shielded if it needs to route near hot temperatures beyond hose component specifications

Hoses should not have sharp bends

Allow sufficient clearance from machine component operational zones such as:

- Drive shafts, universal joints and hitches (i.e. 3-point hitch)
- Pulleys, gears, sprockets
- Deflection and backlash of belts and chains
- Adjustment zones of adjustable brackets
- Changes of position in steering and suspension systems
- Moving linkages, cylinders, articulation joints, attachments
- Ground engaging components

For hose sections that move during machine operation:

- Allow sufficient length for free movement without interference to prevent: pulling, pinching, catching or rubbing, especially in articulation and pivot points
- Clamp hoses securely to force controlled movement to occur in the desired hose section
- Avoid sharp twisting or flexing of hoses in short distances

Protect hoses from:

- Foreign objects such as rocks that may fall or be thrown by the unit
- Buildup of dirt, mud, snow, ice, submersion in water and oil
- Tree limbs, brush and debris
- Damage where service personnel or operators might step or use as a grab bar
- Damage when passing through metal structures
- High pressure wash

**IMPORTANT:** Avoid directly spraying electrical components and connections with high pressure water. High pressure water sprays can penetrate seals and cause electrical components to corrode or otherwise become damaged. When performing maintenance:

- Inspect all electrical components and connections for damage or corrosion. Repair or replace components, connections, or cable as necessary.
- Ensure connections are clean, dry, and not damaged. Repair or replace components, connections, or cable as necessary.
- Clean components or connections using low pressure water, pressurized air, or an aerosol electrical component cleaning agent.



- Remove visible surface water from components, connections, or seals using pressurized air or an aerosol electrical component cleaning agent. Allow components to dry completely before reconnecting cables.



The Hawkeye® nozzle control system is a pressure based product control system designed for precise sprayer application in a variety of conditions. Pressure based application control provides accurate control of droplet size which reduces spray drift during field operations.

Hawkeye is compatible with the ISOBUS communication platform which allows the system to work with most ISO Virtual Terminals (VTs) and Task Controllers on the market. This manual provides installation instructions for:

**TABLE 1. Patriot Make and Model Information**

Make	Model	Model Year	Boom Configuration
Patriot	2250, 3240, 3340, 4440	2017	120' Boom 20" Spacing
			100' Boom 20" Spacing
			90' Boom 20" Spacing
			80' Boom 20" Spacing

## REQUIRED COMPONENTS

The following components must be installed with the Hawkeye nozzle control system:

- Updated software on field computers or control monitors
- PWM pump control valve
- Case IH compatible flow meter
- Case IH compatible pressure transducer
- 80 (or finer) mesh strainer

## TOOLS AND MATERIALS NEEDED

The following tools are recommended for completing the installation:

- SAE and metric sized wrenches and tools
- Drill bit set and drill
- Dielectric grease (supplied)
- Cable ties (supplied)

## POINT OF REFERENCE

The instructions provided in this manual assume the installer is standing behind the machine, looking toward the machine cabin.

## KIT CONTENTS

Basic hardware (nuts, bolts, etc. included with the kit are not included in the table below).

**TABLE 2. Kit, Hawkeye, Patriot MY 2017 and Newer Chassis (P/N 117-1007-147) (Purchased Separately)**  
**Patriot Boom Kit 120' Boom, 20" Spacing, ARAG, Aftermarket (P/N 117-1007-148)**  
**Patriot Boom Kit 100' Boom, 20" Spacing, ARAG, Aftermarket (P/N 117-1007-149)**  
**Patriot Boom Kit 90' Boom, 20" Spacing, ARAG, Aftermarket (P/N 117-1007-150)**  
**Patriot Boom Kit 80' Boom, 20" Spacing, ARAG, Aftermarket (P/N 117-1007-151)**  
**Patriot Boom Kit 120' Boom, 20" Spacing, Wilger, Aftermarket (P/N 117-1007-152)**  
**Patriot Boom Kit 100' Boom, 20" Spacing, Wilger, Aftermarket (P/N 117-1007-153)**  
**Patriot Boom Kit 90' Boom, 20" Spacing, Wilger, Aftermarket (P/N 117-1007-154)**  
**Patriot Boom Kit 80' Boom, 20" Spacing, Wilger, Aftermarket (P/N 117-1007-155)**

Picture	Item Description	Part Number	Qty.											
			117-1007-											
			147	148	149	150	151	152	153	154	155			
Not Pictured	Cable, Adapter, Hawkeye, Left/Right (included as part of kit P/N 117-1007-147)	115-2500-014	1											
Not Pictured	Fuse, 30 Amp, Mini Blade Type (included as part of kit P/N 117-1007-147)	510-1003-044	3											
Not Pictured	Cable, Mid, Case, 120' Boom, 20" Spacing, Molded	115-7303-008		2					2					
Not Pictured	Cable, Outer, Case, 120' Boom, 20" Spacing, Molded	115-7303-009		2					2					
Not Pictured	Cable, Secondary, Case, 100' Boom, 20" Spacing, Molded	115-7303-089			2						2			





Picture	Item Description	Part Number	Qty.										
			117-1007-										
			147	148	149	150	151	152	153	154	155		
Not Pictured	Cable, Outer, Case, 80' Boom, 20" Spacing, Molded	115-7303-200						2					2
Not Pictured	Cable, Primary, Case, 120' Boom, Molded	115-7303-007		2					2				
Not Pictured	Cable, Primary, Case, 80', 90', 100' Boom, Molded	115-7303-088			2	2	2			2	2	2	
	Hawkeye Nozzle Control Valve, ARAG	063-0173-673		72	60	54	48						
	Hawkeye Nozzle Control Valve, Wilger	063-0173-674							72	60	54	48	
	O-Ring, Viton, Green Coated, -115, 56 Pack	219-1005-115M		2	2	1	1						
	O-Ring, Viton, Brown, -116, 56 Pack	219-1005-116M							2	2	1	1	

TABLE 3. 117-1005-057 Kit Components







Picture	Item Description	Part Number	Quantity
	Hawkeye Nozzle Control Valve, ARAG	063-0173-810	1
Not Pictured	Kit, Seal, Hawkeye, ARAG	117-1005-051	3
Not Pictured	Hawkeye Valve Jumper	115-7303-139	2
	Single O-Ring, Viton, Brown, Size -116	219-1005-116	1
	Valve Tool	321-0000-457	2
	Flynut Wrench	321-0000-459	1

TABLE 4. 117-1005-058 Kit Components

Picture	Item Description	Part Number	Quantity
	Hawkeye Nozzle Control Valve, Wilger	063-0173-809	1
Not Pictured	Kit, Seal, Hawkeye, Wilger	117-1005-052	3
Not Pictured	Hawkeye Valve Jumper	115-7303-139	2

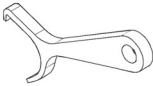
Picture	Item Description	Part Number	Quantity
	Single O-Ring, Viton, Green, Size -115	219-1005-115	1
	Valve Tool	321-0000-457	2
	Flynut Wrench	321-0000-459	1

## UPDATES

Raven software and documentation updates may be made available periodically on the Raven Applied Technology web site:

[www.ravenhelp.com](http://www.ravenhelp.com)

At Raven Industries, we strive to make your experience with our products as rewarding as possible. One way to improve this experience is to provide us with feedback on this manual.

Your feedback will help shape the future of our product documentation and the overall service we provide. We appreciate the opportunity to see ourselves as our customers see us and are eager to gather ideas on how we have been helping or how we can do better.

To serve you best, please send an email with the following information to

[techwriting@ravenind.com](mailto:techwriting@ravenind.com)

- Hawkeye®, Patriot MY 2017 Installation Manual
- P/N 016-0171-645 Rev. B
- Any comments or feedback (include chapter or page numbers if applicable).
- Let us know how long have you been using this or other Raven products.

We will not share your email or any information you provide with anyone else. Your feedback is valued and extremely important to us.

Thank you for your time.





Perform the following procedure to prepare the implement for installation of the Hawkeye® nozzle control system.

	<p><b>CAUTION</b></p> <p>Chemical residues may be present. Thoroughly bleed pressure from chemical lines and rinse the system with clean water prior to installing or servicing fittings, hoses, valves, or nozzles in the application system.</p>
---	--

1. Rinse and fill the tank with clean water.
2. Move the equipment to an open area suitable for testing application system operation and rinsing the boom plumbing.
3. Unfold the boom and enable the application control system. Verify that all control hardware (e.g. control valves, section valves, etc.) and spray tips function as expected.
4. Operate the system until any chemicals are rinsed from the boom supply lines.
5. Disable the application control system and de-pressurize the boom.
6. Replace existing carrier line strainer(s) with an 80 mesh strainer. An 80 mesh or finer strainer is required for use with the Hawkeye® nozzle control system.
7. If turret style nozzle bodies are installed on the implement, rotate the turret to an open spray position, if available. If an open spray position is not available, or for nozzle bodies without a turret, remove the spray tips from the boom and set aside for later use.
8. Enable the application control system and run clean water for at least 20 seconds to rinse any remaining debris from the boom plumbing and nozzle bodies.
9. Remove the cap and diaphragm from the nozzle bodies.

**FIGURE 1. Nozzle Body Cap and Diaphragm Removed**

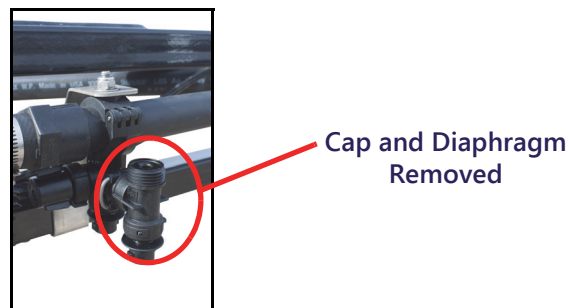



---

## HAWKEYE NOZZLE CONTROL VALVE INSTALLATION

### BEST PRACTICES AND RECOMMENDATIONS

- Do not connect battery leads until all cables are installed and connected.
- If a dual channel turret nozzle body is installed on the implement, always mount the Hawkeye nozzle control valve to the straight nozzle port to avoid excessive pressure drop across the nozzle.

### GENERAL VALVE INSTALLATION

**FIGURE 1. Valve Face O-Ring and Nozzle Control Valve**

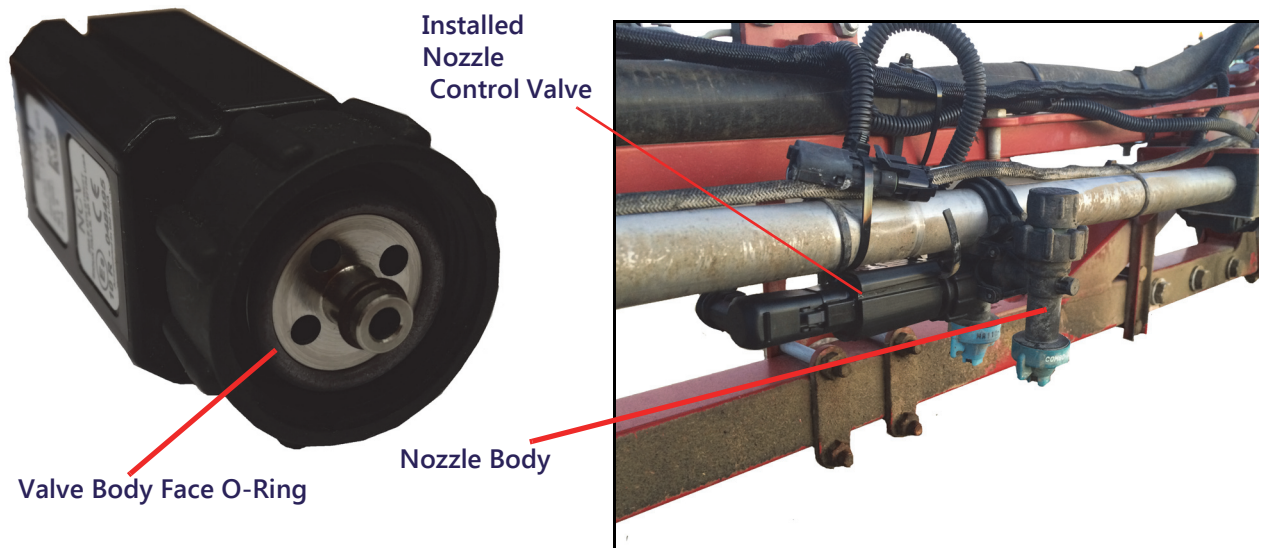

1. Place a supplied o-ring on the inside of the fly nut flush with the valve body face.
2. Thread the fly nut onto the nozzle body.
3. Orient the nozzle control valve so that the label is easily readable.
4. Hand tighten the swivel nut to secure the nozzle control valve to the nozzle body. Do not over tighten.

**NOTE:** Frequently check the nozzle control valve nuts to ensure they are secure.

5. Repeat the previous steps to mount a nozzle control valve to each nozzle body on the spray boom.

## VALVE MOUNTING INTERFERENCE AND OBSTRUCTIONS

In some locations on the spray boom, boom equipment or hardware may interfere with mounting the Hawkeye® nozzle control valves. In these locations, it may be necessary to rotate the nozzle control valve or to relocate existing hardware to provide additional clearance.

**NOTE:** Avoid removing of any existing boom hardware or support brackets where applicable during installation of the Hawkeye nozzle control valves.

See Figure 2 on page 16 for an example of modified installations of the nozzle control valve.

**FIGURE 2. Modified Nozzle Control Valve Installation**

---

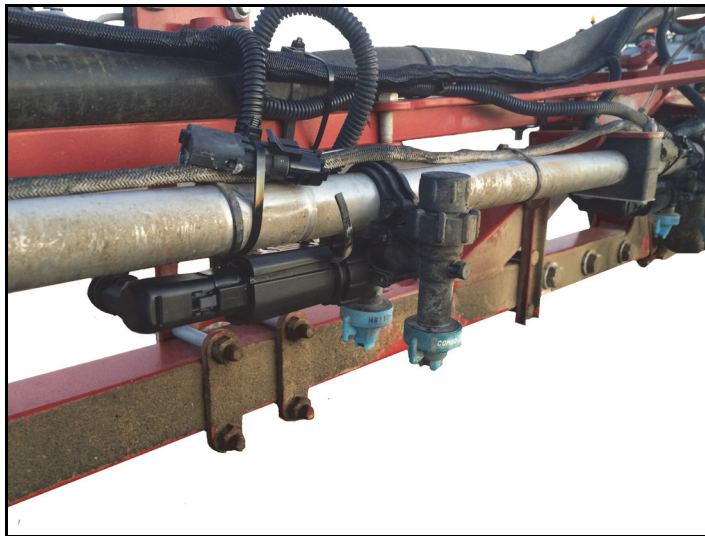

---

## BOOM CABLE ROUTING AND CONNECTION

### BEST PRACTICES AND RECOMMENDATIONS

- Route the Hawkeye primary and secondary boom cables along existing cables or plumbing to help avoid damage to the cable.
- Route cables to avoid pinch points and to avoid stretching the cable during folding and unfolding operations. Pay special attention to cable routing near folding or break-away points.
- Route cables through existing cable retention devices as appropriate.
- When securing the primary and secondary boom cables on the implement, begin at the outer boom tips. Adjust the cable position to provide sufficient slack between valve tee branches while working toward the center of the implement.
- Route the boom cables on the inside of the boom frame work.
- Secure cables using a zip tie at each nozzle control valve tee branch, and one between each tee branch along the cable length.
- Secure the terminators to the cable and to the boom.

## SECONDARY BOOM CABLE ROUTING AND CONNECTIONS

**NOTE:** Please review the Best Practices and Recommendations section on page 16 before routing or securing the boom cables on the implement. Do not connect or secure the cables until instructed to do so in the procedure.

1. Locate the terminator on each of the secondary boom cables (refer to the Kit Contents section on page 8).

**FIGURE 3. Secondary Cable ISOBUS Powell Terminator**



2. Route the secondary boom cables so they are located at the outer tips of the left and right boom.
3. Starting from the mid-boom fold point, feed the terminator end of the secondary boom cable through the boom framework along existing cable or plumbing runs and through any existing cable retention devices as appropriate.
4. If not already applied, apply a single short burst of corrosion inhibitor (Corrosion X HD (Raven P/N 222-0000-020 or available from <http://www.corrosionx.com/corrosionx-heavy-duty.html>)) into the NCV connection. Be sure the corrosion inhibitor has coated the NCV contacts and recessed portions of the connector.

**NOTE:** To determine if corrosion inhibitor has been applied, inspect for a thick liquid in the bottom of the connector.

5. Connect the valve tee branches to the nozzle control valves, starting with the nozzle control valve at the outer end of the boom.

**FIGURE 4. Securing Valve Branches**



6. At each valve branch, adjust the cable as necessary to provide slack between nozzle control valve connections. The large round connector on the secondary boom cable should reach to the mid-boom fold point after all nozzle control valves are connected.

FIGURE 5. Boom Cable Connection at Fold Points

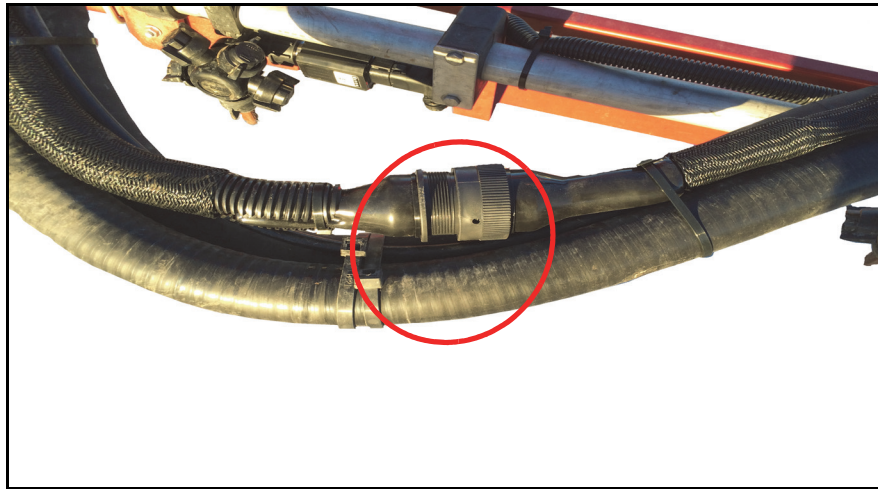

7. Repeat this procedure to route and connect the secondary boom cable on the opposite boom.

**NOTE:** Route and connect the primary and secondary cables before securing the cable with the supplied zip ties.

### PRIMARY BOOM CABLE ROUTING AND CONNECTIONS

**NOTE:** Review the Best Practices and Recommendations section on page 16 before routing or securing the boom cables on the implement. It is recommended not to connect or secure the cable until instructed to do so in the procedure.

1. Locate the large, round connectors on the primary boom cables (refer to the Kit Contents section on page 8). The primary boom cables must be routed such that the connector with female pins is located at the mid-boom fold point of the left or right boom and will connect to the secondary boom cable.

FIGURE 6. Primary Cable Ends



**Male Connector**  
To Center Rack/Chassis Connector



**Female Receptacle**  
To Secondary Boom Cable/Mid-Boom Fold Point

2. Starting at the center of the implement, feed the female receptacle end of the primary boom cable through the boom framework along existing cable or plumbing runs and through any existing cable retention devices as appropriate.

3. Connect the large, round connectors on the primary and secondary boom cables.
4. Adjust the primary and secondary boom cables to ensure sufficient slack around the mid-boom fold point and allow each cable to reach nozzle control valves near the folding point.
5. Secure the primary and secondary connection using the supplied zip ties as necessary to protect the connector from damage during folding and unfolding operations.
6. Once the primary and secondary boom cables are connected, begin connecting the valve tee branches to the nozzle control valves, starting with the valve on the primary boom segment furthest from the center of the implement.
7. At each valve branch, adjust the cable as necessary to provide slack between nozzle control valve connections and use the supplied zip ties to secure the cable at each valve branch. Refer to Figure 4 on page 17. The large, round connector with male pins on the primary boom cable should reach to the center of the implement after all nozzle control valves are connected.
8. Repeat this procedure to route the primary boom cable on the opposite boom.



SYSTEM DIAGRAM

HAWKEYE, PATRIOT MY 2017

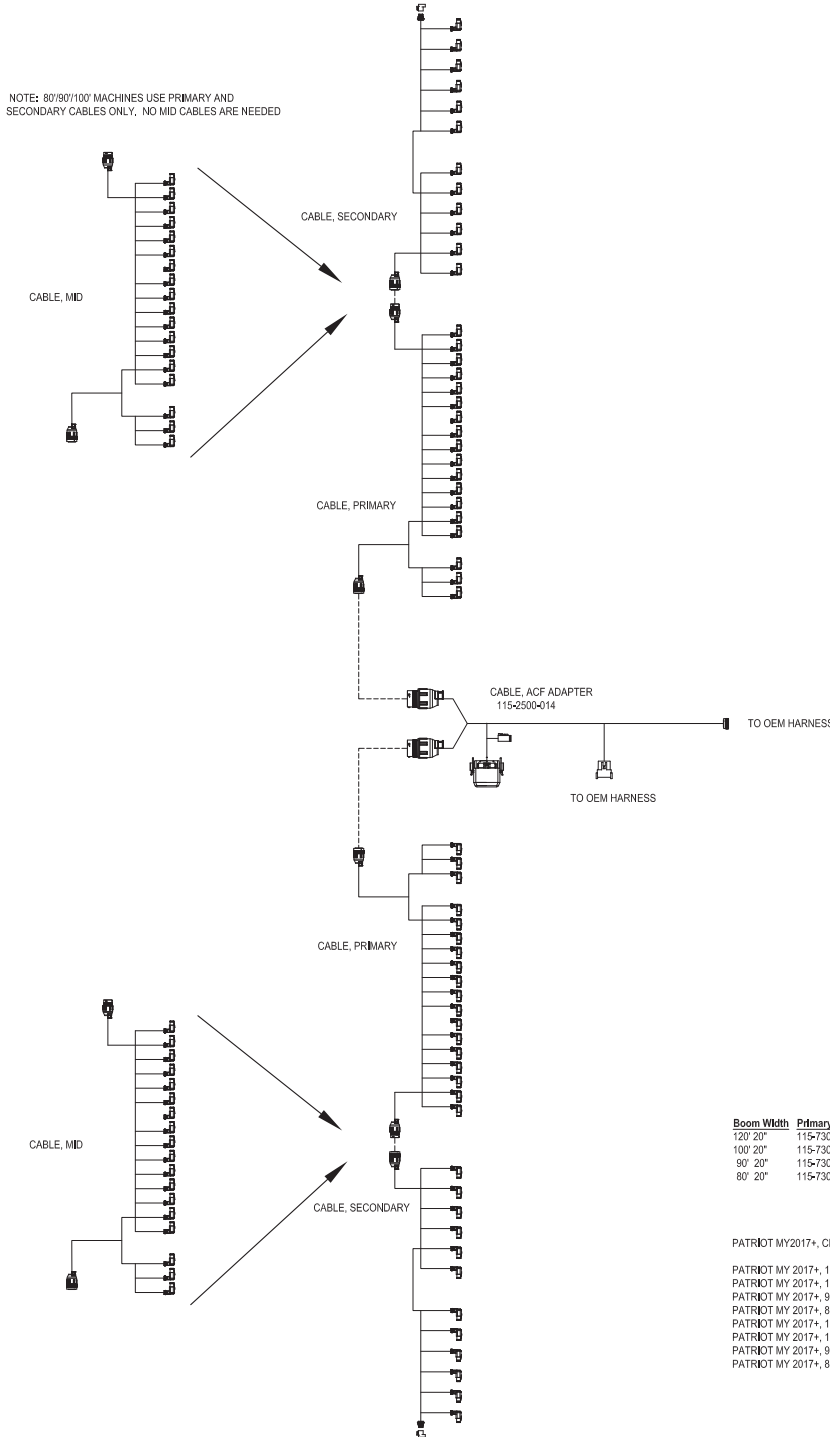



### ADAPTER HARNESS INSTALLATION

1. Locate the Hawkeye adapter harness (115-2500-014).
2. Use the provided hardware to attach the fuse block to the rear of the center rack, near the Product Controller II.
3. Use the provided hardware to attach the three relays to the front side of the Product Controller II mounting plate.

**FIGURE 1. Product Controller II**

---

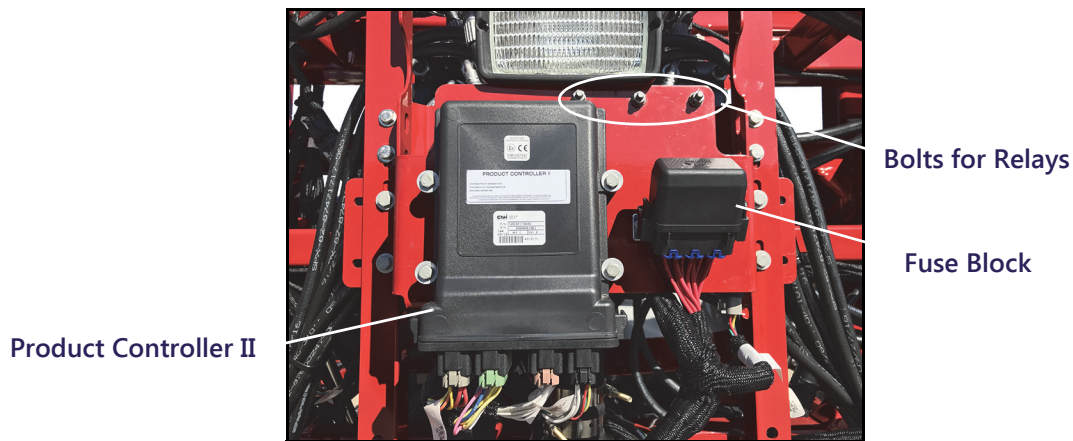

4. Route the 8-pin circular plug to the existing power bulkhead located on the left center rack lift arm.

FIGURE 2. Bulkhead Connector



5. Connect the 12-pin Deutsch receptacle to the mating plug (labeled 'AIM CMD FLEX INTERFACE') located on the center rack, below and to the left of the Product Controller II ECU.

FIGURE 3. 12-Pin Deutsch



6. Route the connectors located "Left Boom" and "Right Boom" to the Primary Hawkeye nozzle cables installed in "Primary Boom Cable Routing and Connections" on page 15.

7. Locate the fuse panel inside the battery compartment, in front of the right rear wheel.

**FIGURE 4. Fuse Panel**

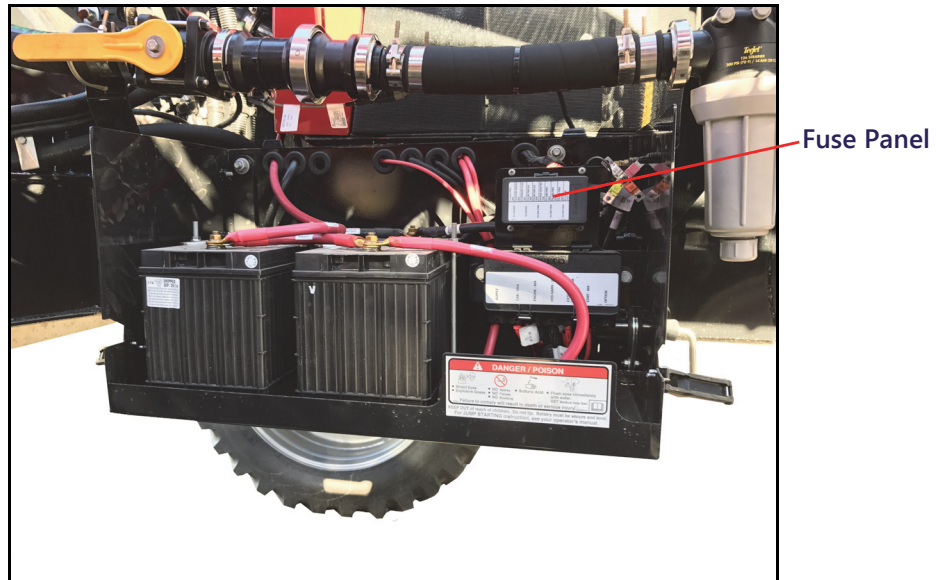

8. Install the 30 Amp fuses in the F7, F8, and F9 spots.



---

## POWER AND ECU HARNESS MAINTENANCE

1. Disconnect the ECU harness connector and inspect for signs of moisture or corrosion.
2. If moisture or corrosion is detected, use Deoxit D5, brushes, and compressed air to clean and dry the connector.
3. When clean, apply a coating of Corrosion X HD to the connector mating surfaces and contacts.
4. Reattach the connectors.

---

## HAWKEYE BOOM HARNESS CONNECTOR MAINTENANCE

Prior to connecting the Hawkeye boom cable to the Hawkeye Nozzle Control Valves (NCV), perform the following steps to all 6-pin NCV connectors and 19-pin circular connectors between the boom cables and ECU cable connections to ensure high quality connections:

1. Verify the NCV connectors and the accompanying boom cable connectors are free of moisture, contamination, or oxidation. Oxidation will appear as a dry, white coating on the contacts. If any connectors show signs of moisture, contamination, or oxidation, perform Step 2 - Step 6. If this is a new installation, skip to Step 7. All components listed below can be ordered in the Hawkeye NCV Connection Maintenance Kit (P/N 117-0171-692).
2. Spray the connection with a deoxidizing agent (DeoxIT D5 is recommended (P/N 222-4001-006)).

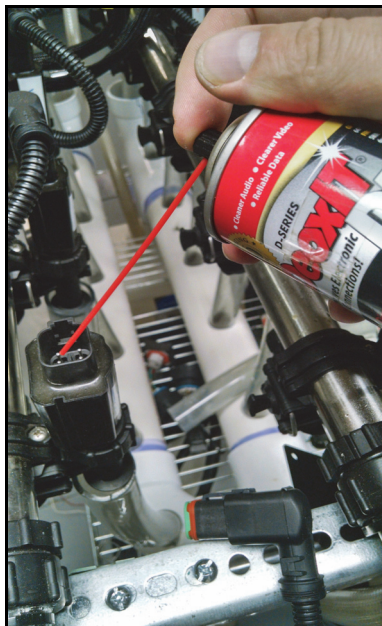

3. Clean contacts with a small wire brush (P/N 321-0000-477).

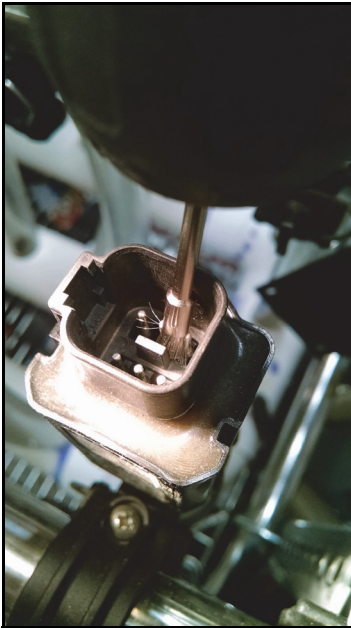

4. Spray the contacts again with the deoxidizing agent. This will rinse out debris.
5. Remove all residue of deoxidizing agent from the connection. Not removing deoxidizing agent can damage the connector seal.
6. Dry out the connection with dry, compressed air. Dust Off Electronics Duster (P/N 222-4001-007) is recommended however, if unavailable, alternate compressed air sources can be used. If using compressed air from a large volume air compressor, be sure the lines are free of moisture.





7. If not already applied, apply a single short burst of corrosion inhibitor (Corrosion X HD (Raven P/N 222-0000-020 or available from <http://www.corrosionx.com/corrosionx-heavy-duty.html>)) into the NCV connection. Be sure the corrosion inhibitor has coated the NCV contacts and recessed portions of the connector.

**NOTE:** To determine if corrosion inhibitor has been applied, inspect for a thick liquid in the bottom of the connector (as shown in the Corrosion Inhibitor Applied image below).

**NCV Connector**

Spray in  
Void  
Between  
Pins

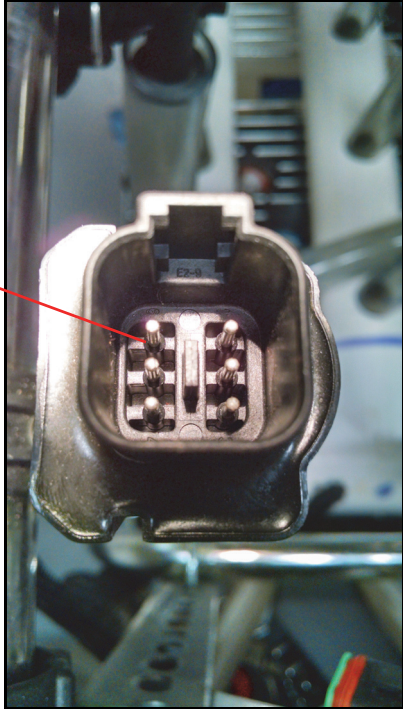

**Applying Corrosion Inhibitor**

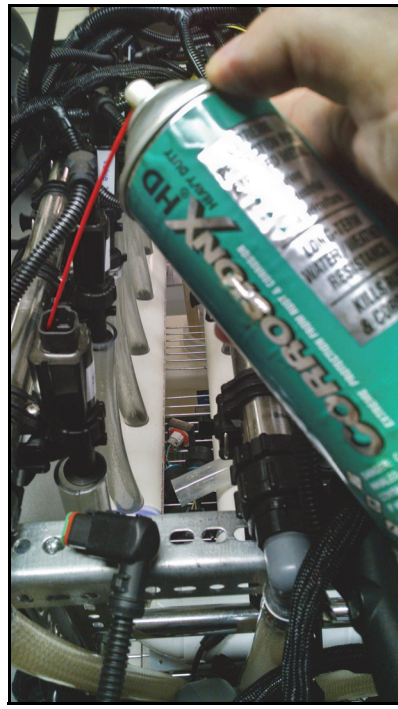

**Corrosion Inhibitor Applied**

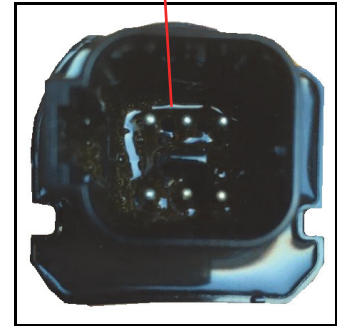





# RAVEN

## Limited Warranty

---

### ***What Does this Warranty Cover?***

This warranty covers all defects in workmanship or materials in your Raven Applied Technology Division product under normal use, maintenance, and service when used for intended purpose.

### ***How Long is the Coverage Period?***

Raven Applied Technology products are covered by this warranty for 12 months from the date of retail sale. In no case will the Limited Warranty period exceed 24 months from the date the product was issued by Raven Industries Applied Technology Division. This warranty coverage applies only to the original owner and is non-transferable.

### ***How Can I Get Service?***

Bring the defective part and proof of purchase to your Raven dealer. If the dealer approves the warranty claim, the dealer will process the claim and send it to Raven Industries for final approval. The freight cost to Raven Industries will be the customer's responsibility. The Return Materials Authorization (RMA) number must appear on the box and all documentation (including proof of purchase) must be included inside the box to be sent to Raven Industries.

### ***What Will Raven Industries Do?***

Upon confirmation of the warranty claim, Raven Industries will (at our discretion) repair or replace the defective product and pay for the standard return freight, regardless of the inbound shipping method. Expedited freight is available at the customer's expense.

### ***What is not Covered by this Warranty?***

Raven Industries will not assume any expense or liability for repairs made outside our facilities without written consent. Raven Industries is not responsible for damage to any associated equipment or products and will not be liable for loss of profit, labor, or other damages. The obligation of this warranty is in lieu of all other warranties, expressed or implied, and no person or organization is authorized to assume any liability for Raven Industries.

**Damages caused by normal wear and tear, misuse, abuse, neglect, accident, or improper installation and maintenance are not covered by this warranty.**



## Extended Warranty

### ***What Does this Warranty Cover?***

This warranty covers all defects in workmanship or materials in your Raven Applied Technology Division product under normal use, maintenance, and service when used for intended purpose.

### ***Do I Need to Register My Product to Qualify for the Extended Warranty?***

Yes. Products/systems must be registered within 30 days of retail sale to receive coverage under the Extended Warranty. If the component does not have a serial tag, the kit it came in must be registered instead.

### ***Where Can I Register My Product for the Extended Warranty?***

To register, go online to [www.ravenhelp.com](http://www.ravenhelp.com) and select Product Registration.

### ***How Long is the Extended Warranty Coverage Period?***

Raven Applied Technology products that have been registered online are covered for an additional 12 months beyond the Limited Warranty for a total coverage period of 24 months from the date of retail sale. In no case will the Extended Warranty period exceed 36 months from the date the product was issued by Raven Industries Applied Technology Division. This Extended Warranty coverage applies only to the original owner and is non-transferable.

### ***How Can I Get Service?***

Bring the defective part and proof of purchase to your Raven dealer. If the dealer approves the warranty claim, the dealer will process the claim and send it to Raven Industries for final approval. The freight cost to Raven Industries will be the customer's responsibility. The Return Materials Authorization (RMA) number must appear on the box and all documentation (including proof of purchase) must be included inside the box to be sent to Raven Industries. In addition, the words "Extended Warranty" must appear on the box and all documentation if the failure is between 12 and 24 months from the retail sale.

### ***What Will Raven Industries Do?***

Upon confirmation of the product's registration for the Extended Warranty and the claim itself, Raven Industries will (at our discretion) repair or replace the defective product and pay for the standard return freight, regardless of the inbound shipping method. Expedited freight is available at the customer's expense.

### ***What is Not Covered by the Extended Warranty?***

Raven Industries will not assume any expense or liability for repairs made outside our facilities without written consent. Raven Industries is not responsible for damage to any associated equipment or products and will not be liable for loss of profit, labor, or other damages. Cables, hoses, software enhancements, and remanufactured items are not covered by this Extended Warranty. The obligation of this warranty is in lieu of all other warranties, expressed or implied, and no person or organization is authorized to assume any liability for Raven Industries.

**Damages caused by normal wear and tear, misuse, abuse, neglect, accident, or improper installation and maintenance are not covered by this warranty.**