

**AGCO RoGator RG700  
Hawkeye® Installation  
Manual**

*P/N 016-0171-613 Rev. B*

*04-17*

*E29395*

## ***Disclaimer***

---

While every effort has been made to ensure the accuracy of this document, Raven Industries assumes no responsibility for omissions and errors. Nor is any liability assumed for damages resulting from the use of information contained herein.

Raven Industries shall not be responsible or liable for incidental or consequential damages or a loss of anticipated benefits or profits, work stoppage or loss, or impairment of data arising out of the use, or inability to use, this system or any of its components. Raven Industries shall not be held responsible for any modifications or repairs made outside our facilities, nor damages resulting from inadequate maintenance of this system.

As with all wireless and satellite signals, several factors may affect the availability and accuracy of wireless and satellite navigation and correction services (e.g. GPS, GNSS, SBAS, etc.). Therefore, Raven Industries cannot guarantee the accuracy, integrity, continuity, or availability of these services and cannot guarantee the ability to use Raven systems, or products used as components of systems, which rely upon the reception of these signals or availability of these services. Raven Industries accepts no responsibility for the use of any of these signals or services for other than the stated purpose.

---

|                   |  |           |
|-------------------|--|-----------|
| <b>Chapter 1</b>  | <b><i>Important Safety Information</i></b> .....       | <b>1</b>  |
|                   | Instructions for Wire Routing .....                    | 2         |
|                   | Instructions for Hose Routing .....                    | 3         |
| <b>Chapter 2</b>  | <b><i>Introduction</i></b> .....                       | <b>5</b>  |
|                   | Overview of the Installation Process .....             | 5         |
|                   | Required Components .....                              | 6         |
|                   | Tools and Materials Needed .....                       | 6         |
|                   | Point of Reference .....                               | 6         |
|                   | Kit Contents .....                                     | 6         |
|                   | Updates .....  | 10        |
| <b>Chapter 3</b>  | <b><i>Installation Preparation</i></b> .....           | <b>11</b> |
| <b>Chapter 4</b>  | <b><i>Nozzle Control Valve Installation</i></b> .....  | <b>13</b> |
|                   | Hawkeye Nozzle Control Valve Installation .....        | 13        |
|                   | Best Practices and Recommendations .....               | 13        |
|                   | Boom Cable Routing and Connection .....                | 15        |
|                   | Best Practices and Recommendations .....               | 15        |
|                   | Secondary Boom Cable Routing and Connections .....     | 15        |
|                   | Primary Boom Cable Routing and Connections .....       | 17        |
| <b>Chapter 5</b>  | <b><i>ISOBUS ECU Mounting and Connection</i></b> ..... | <b>19</b> |
|                   | Product Controller II ECU Installation .....           | 19        |
|                   | Best Practices and Recommendations .....               | 19        |
|                   | Electrical Box Preparation .....                       | 19        |
|                   | Mounting Plate Preparation and ECU Installation .....  | 20        |
|                   | ECU Retrofit Cable Installation .....                  | 21        |
| <b>Chapter 6</b>  | <b><i>Chassis Installation</i></b> .....               | <b>25</b> |
|                   | Chassis Cable Routing and Connection .....             | 25        |
|                   | Best Practices and Recommendations .....               | 25        |
|                   | Electrical Box Connection .....                        | 25        |
|                   | Center Rack Routing and Boom Cable Connections .....   | 25        |
|                   | Battery Compartment and Connections .....              | 26        |
|                   | System Diagrams .....                                  | 27        |
| <b>Appendix A</b> | <b><i>ISOBUS Adapter</i></b> .....                     | <b>31</b> |
|                   | Viper 4 ISOBUS Adapter Cable .....                     | 31        |

|                  |   |           |
|------------------|---|-----------|
| <b>Chapter B</b> | <b><i>Cable and Connector Maintenance</i></b> ..... | <b>33</b> |
|                  | Power and ECU Harness Maintenance .....             | <b>33</b> |
|                  | Hawkeye Boom Harness Connector Maintenance .....    | <b>33</b> |

---

# CHAPTER

# 1

# IMPORTANT SAFETY INFORMATION

---

## NOTICE

Read this manual and all operation and safety instructions included with the implement and/or controller carefully before installing the Hawkeye system.

- Follow all safety information presented within this manual.
- If you require assistance with any portion of the installation or service of Raven equipment, contact a local Raven dealer for support.
- Follow all safety labels affixed to system components. Be sure to keep safety labels in good condition and replace any missing or damaged labels. To obtain replacements for missing or damaged safety labels, contact a local Raven dealer.

When operating the machine, observe the following safety measures:

- Be alert and aware of surroundings.
- Do not operate agricultural equipment while under the influence of alcohol or an illegal substance.
- Remain in the operator's position in the machine at all times when equipment is engaged. Disable system functions or features when exiting from the operator's seat and machine.
- Do not drive the machine with equipment enabled on any public road.
- Determine and retain a safe working distance from other individuals. The operator is responsible for disabling Hawkeye when the safe working distance has been diminished.
- Ensure Hawkeye is disabled prior to starting any maintenance work on the system or the implement.

## DANGER

### AGRICULTURAL CHEMICAL SAFETY

- Thoroughly bleed pressure from chemical lines and rinse the system with clean water prior to installing or servicing fittings, hoses, valves, or nozzles in the application system.
- Always follow safety labels and instructions provided by the chemical manufacturer or supplier.
- Always wear appropriate personal protective equipment as recommended by the chemical and/or equipment manufacturer.
- Fill, flush, calibrate, and decontaminate chemical application systems in an area where runoff will not reach ponds, lakes, streams, livestock areas, gardens, or populated areas.
- Avoid inhaling chemical dust or spray particulate and avoid direct contact with any agricultural chemicals. Seek immediate medical attention if symptoms of illness occur during, or soon after, use of agricultural chemicals, products, or equipment.
- After handling or applying agricultural chemicals:

- Thoroughly wash hands and face after using agricultural chemicals and before eating, drinking, or using the rest room.
- Thoroughly flush or rinse equipment used to mix, transfer, or apply chemicals with water after use or before servicing any component of the application system.
- Follow all federal, state, and local regulations regarding the handling, use, and disposal of agricultural chemicals, products, and containers. Triple-rinse and puncture or crush empty containers before disposing of them properly. Contact a local environmental agency or recycling center for additional information.

## CAUTION

### ELECTRICAL SAFETY

- Always verify that the power leads are connected to the correct polarity as marked. Reversing the power leads could cause severe damage to the equipment.
- Disconnect the Hawkeye system ECUs and control console before jump starting the vehicle or welding on any part of the implement or machine.

---

## INSTRUCTIONS FOR WIRE ROUTING

The word “harness” is used to mean all electrical leads and cables, bundled and unbundled. When installing harness, secure it at least every 30 cm (12in) to the frame. Follow existing harness as much as possible and use these guidelines:

Harness should not contact or be attached to:

- Lines and hoses with high vibration forces or pressure spikes
- Lines and hoses carrying hot fluids beyond harness component specifications

Avoid contact with any sharp edge or abrading surfaces such as, but not limited to:

- Sheared or flame cut edges
- Edges of machined surfaces
- Fastener threads or cap screw heads
- Ends of adjustable hose clamps
- Wire exiting conduit without protection, either ends or side of conduit
- Hose and tube fittings

Routing should not allow harnesses to:

- Hang below the unit
- Have the potential to become damaged due to exposure to the exterior environment. (i.e. tree limbs, debris, attachments)
- Be placed in areas of or in contact with machine components which develop temperatures higher than the temperature rating of harness components
- Wiring should be protected or shielded if it needs to route near hot temperatures beyond harness component specifications

Harnessing should not have sharp bends

Allow sufficient clearance from machine component operational zones such as:

- Drive shafts, universal joints and hitches (i.e. 3-point hitch)
- Pulleys, gears, sprockets
- Deflection and backlash of belts and chains
- Adjustment zones of adjustable brackets
- Changes of position in steering and suspension systems
- Moving linkages, cylinders, articulation joints, attachments
- Ground engaging components

For harness sections that move during machine operation:

- Allow sufficient length for free movement without interference to prevent: pulling, pinching, catching or rubbing, especially in articulation and pivot points
- Clamp harnesses securely to force controlled movement to occur in the desired harness section
- Avoid sharp twisting or flexing of harnesses in short distances
- Connectors and splices should not be located in harness sections that move

Protect harnesses from:

- Foreign objects such as rocks that may fall or be thrown by the unit
- Buildup of dirt, mud, snow, ice, submersion in water and oil
- Tree limbs, brush and debris
- Damage where service personnel or operators might step or use as a grab bar
- Damage when passing through metal structures

**IMPORTANT:** Avoid directly spraying electrical components and connections with high pressure water. High pressure water sprays can penetrate seals and cause electrical components to corrode or otherwise become damaged. When performing maintenance:

- Inspect all electrical components and connections for damage or corrosion. Repair or replace components, connections, or cable as necessary.
- Ensure connections are clean, dry, and not damaged. Repair or replace components, connections, or cable as necessary.
- Clean components or connections using low pressure water, pressurized air, or an aerosol electrical component cleaning agent.
- Remove visible surface water from components, connections, or seals using pressurized air or an aerosol electrical component cleaning agent. allow components to dry completely before reconnecting cables.

---

## INSTRUCTIONS FOR HOSE ROUTING

The word "hose" is used to mean all flexible fluid carrying components. Follow existing hoses as much as possible and use these guidelines:

Hoses should not contact or be attached to:

- Components with high vibration forces
- Components carrying hot fluids beyond component specifications

Avoid contact with any sharp edge or abrading surfaces such as, but not limited to:

- Sheared or flame cut edges
- Edges of machined surfaces
- Fastener threads or cap screw heads
- Ends of adjustable hose clamps

Routing should not allow hoses to:

- Hang below the unit
- Have the potential to become damaged due to exposure to the exterior environment. (i.e. tree limbs, debris, attachments)
- Be placed in areas of or in contact with machine components which develop temperatures higher than the temperature rating of hose components
- Hoses should be protected or shielded if it needs to route near hot temperatures beyond hose component specifications

Hoses should not have sharp bends

Allow sufficient clearance from machine component operational zones such as:

- Drive shafts, universal joints and hitches (i.e. 3-point hitch)
- Pulleys, gears, sprockets
- Deflection and backlash of belts and chains
- Adjustment zones of adjustable brackets
- Changes of position in steering and suspension systems
- Moving linkages, cylinders, articulation joints, attachments
- Ground engaging components

For hose sections that move during machine operation:

- Allow sufficient length for free movement without interference to prevent: pulling, pinching, catching or rubbing, especially in articulation and pivot points
- Clamp hoses securely to force controlled movement to occur in the desired hose section
- Avoid sharp twisting or flexing of hoses in short distances

Protect hoses from:

- Foreign objects such as rocks that may fall or be thrown by the unit
- Buildup of dirt, mud, snow, ice, submersion in water and oil
- Tree limbs, brush and debris
- Damage where service personnel or operators might step or use as a grab bar
- Damage when passing through metal structures
- High pressure wash



The Hawkeye nozzle control system is a pressure based product control system designed for precise sprayer application in a variety of conditions. Pressure based application provides accurate control of droplet size which reduces spray drift during field operations.

The Hawkeye is compatible with the ISOBUS communication platform which allows the system to work with most ISO Virtual Terminals (VTs) and Task Controllers on the market. This manual is intended to provide installation instructions on the following equipment:

**TABLE 1. AGCO RoGator Make and Model Information**

| Make | Model       | Model Years    | Boom Configuration                        |
|------|-------------|----------------|---|
| AGCO | RoGator 700 | 2014 and Newer | 60'/80' Combo Boom<br>20" and 15" Spacing |
|      |             |                | 60'/90' Combo Boom<br>20" and 15" Spacing |

**FIGURE 1. RoGator 1300B**



## OVERVIEW OF THE INSTALLATION PROCESS

The recommended process for installing the Hawkeye nozzle control system is as follows:

1. Check Hawkeye kit contents. See the Kit Contents section on page 6.
2. Replace existing strainer with an 80 mesh (or finer) strainer for use with the Hawkeye nozzle control system. See the Hawkeye Installation Preparation section on page 7.

3. Remove spray tips and flush each section individually for a minimum of 20 seconds to thoroughly flush the boom.
4. Mount Hawkeye nozzle control valves. See the Hawkeye Nozzle Control Valve Installation section on page 8.
5. Route and connect the secondary and primary boom cables. See the Boom Cable Routing and Connection section on page 10.
6. Mount the Hawkeye product controller II ECU. See the Product Controller II ECU Installation section on page 13.
7. Route and connect chassis cable. See the Chassis Cable Routing and Connection section on page 19.

### REQUIRED COMPONENTS

The following components must be installed with the Hawkeye nozzle control system:

- Updated software on field computers or control monitors. Contact your local RoGator dealer for the latest version of C1000 software.
- PWM pump control valve
- Raven compatible flow meter
- Raven compatible pressure transducer
- 80 mesh (or finer) strainer

**NOTE:** Do not use air induction tips with the Hawkeye nozzle control system. A fan or cone style spray tip is required for the Hawkeye system to operate properly.

### TOOLS AND MATERIALS NEEDED

The following tools are recommended for completing the installation:

- SAE and metric sized wrenches and tools
- Drill bit set and drill
- Dielectric grease (supplied)
- Cable ties (supplied)

### POINT OF REFERENCE

The instructions provided in this manual assume the installer is standing behind the machine, looking toward the machine cabin.



---

### KIT CONTENTS

**TABLE 2. RoGator RG700, 60'/90' Combo Boom, 20" Spacing, Hypro, Aftermarket (P/N 117-1007-026)  
RoGator RG700, 60'/80' Combo Boom, 20" Spacing, Hypro, Aftermarket (P/N 117-1007-027) RoGator**

RG700, 60'/90' Combo Boom, 15" Spacing, Hypro, Aftermarket (P/N 117-1007-028) RoGator RG700, 60'/80' Combo Boom, 15" Spacing, Hypro, Aftermarket (P/N 117-1007-029)

| Picture   | Item Description                                     | Part Number  | Qty.      |     |     |     |
|---|--|--------------|-----------|-----|-----|-----|
|   |  |              | 117-1005- |     |     |     |
|   |  |              | 026       | 027 | 028 | 029 |
| Not Pictured  | Manual - Hawkeye® Calibration and Operation          | 016-0171-584 | 1         |     |     |     |
| Not Pictured  | Manual - AGCO RoGator RG700 Hawkeye Installation     | 016-0171-613 | 1         |     |     |     |
| Not Pictured  | Quick Start Guide - Hawkeye Start-Up                 | 016-0171-598 | 1         |     |     |     |
|   | Cable - AGCO Boom Sense Retrofit                     | 115-7303-084 | 1         |     |     |     |
|  | ECU - ISO Product Controller II                      | 063-0173-704 | 1         |     |     |     |
|  | ECU - ISO Boom Sense/Speed                           | 063-0173-635 | 1         |     |     |     |
|  | Cable, Adapter, Viper 4 to 3-Pin ISObus              | 115-0172-247 | 1         |     |     |     |
| Not Pictured  | Cable, Logic Power/CAN, ECU, RG700 Retrofit, Hawkeye | 115-7303-190 | 1         |     |     |     |

| Picture   | Item Description  | Part Number   | Qty.      |     |     |     |
|---|---|---------------|-----------|-----|-----|-----|
|   |   |               | 117-1005- |     |     |     |
|   |   |               | 026       | 027 | 028 | 029 |
| Not Pictured  | Cable, Primary, RG700, 60'/80' and 90' Boom, 20" Spacing, Hawkeye       | 115-7303-191  | 2         | 2   |     |     |
|   | Cable, Right Primary, RG700, 60'/80' and 90' Boom, 15" Spacing, Hawkeye | 115-7303-133  |           |     | 1   | 1   |
|   | Cable, Left Primary, RG700, 60'/80' and 90' Boom, 15" Spacing, Hawkeye  | 115-7303-132  |           |     | 1   | 1   |
| Not Pictured  | Cable, Secondary, RG700, 60'/90' Boom, 20" Spacing, Hawkeye             | 115-7303-192  | 2         |     |     |     |
|   | Cable, Secondary, RG700, 60'/80' Boom, 20" Spacing, Hawkeye             | 115-7303-193  |           | 2   |     |     |
|   | Cable, Secondary, RG700, 60'/90' Boom, 15" Spacing, Hawkeye             | 115-7303-134  |           |     | 2   |     |
|   | Cable, Secondary, RoGator RG700, 60/80, 15" Hawkeye                     | 115-7303-127  |           |     |     | 2   |
|   | Cable, HC Power/Boom Feed, AGCO Retrofit, Hawkeye                       | 115-7303-189  | 1         |     |     |     |
|  | Hawkeye Nozzle Control Valve, Hypro                                     | 063-0173-673  | 54        | 48  | 71  | 63  |
|  | O-Ring, Viton, Green Coated, -115, 56 Pack                              | 219-1005-115M | 1         | 1   | 2   | 2   |



| Picture   | Item Description                               | Part Number  | Qty.      |     |     |     |
|---|--|--------------|-----------|-----|-----|-----|
|   |  |              | 117-1005- |     |     |     |
|   |  |              | 026       | 027 | 028 | 029 |
|    | Nozzle Body, Triple Nozzle, 1" Wet Boom, Hypro | 334-0002-196 | 2         |     |     |     |
| Not Pictured  | Hawkeye System Service Kit                     | 117-1005-057 | 1         |     |     |     |
|    | Bolt, 1/4-20 x 1.5" LG Hex Head                | 311-0050-107 | 4         |     |     |     |
|    | Nut, Flanged Lock 1/4 - 20 Zinc                | 312-1001-168 | 4         |     |     |     |
|  | Washer 265 ID x.505OD x .060 Thk               | 313-2300-120 | 4         |     |     |     |

TABLE 3. Hawkeye Service Kit Components (P/N 117-1005-056)

| Picture   | Item Description                     | Part Number  | Quantity |
|---|--------------------------------------|--------------|----------|
|  | Hawkeye Nozzle Control Valve, TeeJet | 063-0173-672 | 1        |
| Not Pictured  | Kit, Seal, Hawkeye Valve, TeeJet     | 117-1005-050 | 3        |
| Not Pictured  | Hawkeye Valve Jumper                 | 115-7303-139 | 2        |
|  | Hawkeye Valve Tool                   | 321-0000-457 | 2        |
|  | Hawkeye Fly Nut Wrench               | 321-0000-459 | 1        |

## UPDATES

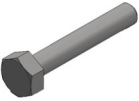
Raven software and documentation updates may be made available periodically on the Raven Applied Technology web site:

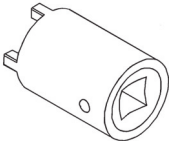
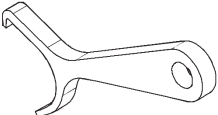
[www.ravenhelp.com](http://www.ravenhelp.com)

At Raven Industries, we strive to make your experience with our products as rewarding as possible. One way to improve this experience is to provide us with feedback on this manual.

Your feedback will help shape the future of our product documentation and the overall service we provide. We appreciate the opportunity to see ourselves as our customers see us and are eager to gather ideas on how we have been helping or how we can do better.

To serve you best, please send an email with the following information to

[techwriting@ravenind.com](mailto:techwriting@ravenind.com)

- AGCO RoGator RG700 Hawkeye® Installation Manual
- P/N 016-0171-613 Rev. B
- Any comments or feedback (include chapter or page numbers if applicable).
- Let us know how long have you been using this or other Raven products.

We will not share your email or any information you provide with anyone else. Your feedback is valued and extremely important to us.

Thank you for your time.

Perform the following procedure to prepare the implement for installation of the Hawkeye nozzle control system.

|   |  |
|---|--|
|  | <p><b>CAUTION</b></p> <p>Chemical residues may be present. Thoroughly bleed pressure from chemical lines and rinse the system with clean water prior to installing or servicing fittings, hoses, valves, or nozzles in the application system.</p> |
|---|--|

1. Rinse and fill the tank with clean water.
2. Move the equipment to an open area suitable for testing application system operation and rinsing the boom plumbing.
3. Unfold the boom and enable the application control system. Verify that all control hardware (e.g. control valves, section valves, etc.) and spray tips function as expected.
4. Operate the system until any chemicals are rinsed from the boom supply lines.
5. Disable the application control system and de-pressurize the boom.
6. Replace existing carrier line strainer(s) with an 80 mesh strainer. An 80 mesh (or finer) strainer is required for use with the Hawkeye nozzle control system.
7. If turret style nozzle bodies are installed on the implement, rotate the turret to an open spray position, if available. If an open spray position is not available, or for nozzle bodies without a turret, remove the spray tips from the boom and set aside for later use.
8. Enable the application control system and run clean water for at least 20 seconds to rinse any remaining debris from the boom plumbing and nozzle bodies.
9. Remove the cap and diaphragm from the nozzle bodies.

**FIGURE 1. Nozzle Body Cap and Diaphragm Removed**



Cap and  
Diaphragm  
Removed





# CHAPTER

# 4

# NOZZLE CONTROL VALVE INSTALLATION

## HAWKEYE NOZZLE CONTROL VALVE INSTALLATION

After the plumbing has been rinsed of debris, the Hawkeye nozzle control valves may be mounted to the existing nozzle bodies.

### BEST PRACTICES AND RECOMMENDATIONS

- Do not connect battery leads until all cables are installed and connected.
- If a dual channel turret nozzle body is installed on the implement, always mount the Hawkeye nozzle control valve to the straight nozzle port to avoid excessive pressure drop across the nozzle.
- If there are obstacles that interfere with the Hawkeye valve installation it may be necessary to purchase a different brand of nozzle body with a threaded port on the opposite side.

### GENERAL VALVE INSTALLATION

**FIGURE 1. Valve Face O-Ring and Nozzle Control Valve**

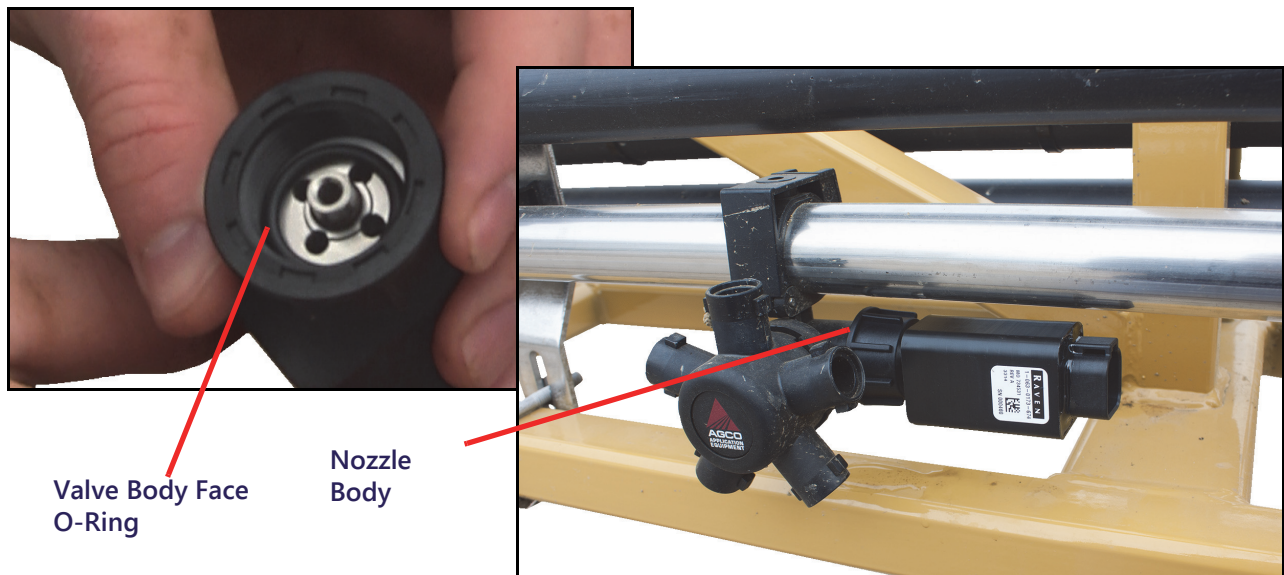

1. Place a supplied o-ring on the inside of the fly nut flush with the valve body face.

**NOTE:** If using TeeJet QJS (straight) nozzle bodies, use the green coated (size 115) o-ring. For TeeJet QJ (turret) nozzle bodies, use the brown/gray (size 116) o-rings.

For AGCO Hypro nozzle bodies, use the green coated (size 115) o-ring.

FIGURE 2. Green Coated and Brown/Gray O-Rings



2. Thread the fly nut onto the nozzle body.
3. Orient the nozzle control valve so that the label is easily readable.
4. Hand tighten the swivel nut to secure the nozzle control valve to the nozzle body. If needed, use the Hawkeye fly wrench provided in the System Service kit. Do not over tighten.

**NOTE:** Frequently check the nozzle control valve nuts to ensure they are secure.

5. Repeat the previous steps to mount a nozzle control valve to each nozzle body on the spray boom.

#### VALVE MOUNTING INTERFERENCE AND OBSTRUCTIONS

In some locations on the spray boom, boom equipment or hardware may interfere with mounting the Hawkeye nozzle control valves. In these locations, there are a few options to get around the interferences:

1. Rotate the nozzle control valve so the round, lowest-profile side of the NCV is towards the interference.

FIGURE 3. Modified Nozzle Control Valve Installation

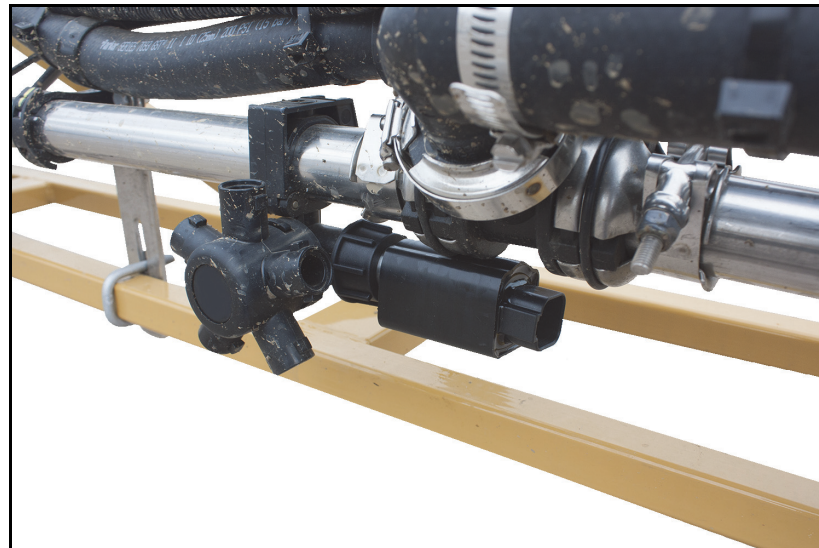

2. Loosen the brackets and slide them down, out of the way of the NCV. Verify the brackets still adequately support the components as intended. Do not remove the brackets completely.
3. If the first two options do not solve the interference, swap the AGCO nozzle body for a triple nozzle body (provided in the kit) with the threaded connection for the Hawkeye valve facing away from the interference.

FIGURE 4. Triple Nozzle Body Installed



**NOTE:** Avoid removing of any existing boom hardware or support brackets where applicable during installation of the Hawkeye nozzle control valves.

Verify the terminators are secured to the main cable trunk using a zip tie through the connector retainer clip. If terminators are not secured, wire breakage could occur.

## BOOM CABLE ROUTING AND CONNECTION

### BEST PRACTICES AND RECOMMENDATIONS

- Route the Hawkeye primary and secondary boom cables along existing cables or plumbing to help avoid damage to the cable.
- Route cables to avoid pinch points and to avoid stretching the cable during folding and unfolding operations. Pay special attention to cable routing near folding or break-away points.
- Route cables through existing cable retention devices as appropriate.
- When securing the primary and secondary boom cables on the implement, begin at the outer boom tips. Adjust the cable position to provide sufficient slack between valve tee branches while working toward the center of the implement.
- Route the boom cables on the inside of the boom frame work if possible.
- Secure cables using a zip tie at each nozzle control valve tee branch, and one between each tee branch along the cable length.

### SECONDARY BOOM CABLE ROUTING AND CONNECTIONS

**NOTE:** Please review the Best Practices and Recommendations section on page 15 before routing or securing the boom cables on the implement. It is recommended not to connect or secure the cable until instructed to do so in the procedure.

1. Locate the terminator on each of the secondary boom cables (refer to the Kit Contents section on page 6).

FIGURE 5. Secondary Cable ISOBUS Powell Terminator



2. Route the secondary boom cables to the outer tips of the left and right boom.
3. Starting from the mid-boom fold point, feed the terminator end of the secondary boom cable through the boom framework along existing cable or plumbing runs and through any existing cable retention devices as appropriate.

**NOTE:** If there is interference between the connector and boom components, remove the 90° back shell from the connector. Refer to Figure 7 on page 17.

4. If not already applied, apply a single short burst of corrosion inhibitor (Corrosion X HD (Raven P/N 222-0000-020 or available from <http://www.corrosionx.com/corrosionx-heavy-duty.html>)) into the NCV connection. Be sure the corrosion inhibitor has coated the NCV contacts and recessed portions of the connector.

**NOTE:** To determine if corrosion inhibitor has been applied, inspect for a thick liquid in the bottom of the connector.

5. Starting with the nozzle control valve at the outer end of the boom, connect the valve tee branches to the nozzle control valves.

FIGURE 6. Securing Valve Branches



6. At each valve branch, adjust the cable as necessary to provide slack between nozzle control valve connections. The large round connector on the secondary boom cable should reach to the mid-boom fold point after all nozzle control valves are connected.

---

**FIGURE 7. Primary and Secondary Boom Cable Connection at Mid-Boom Fold Point**

---

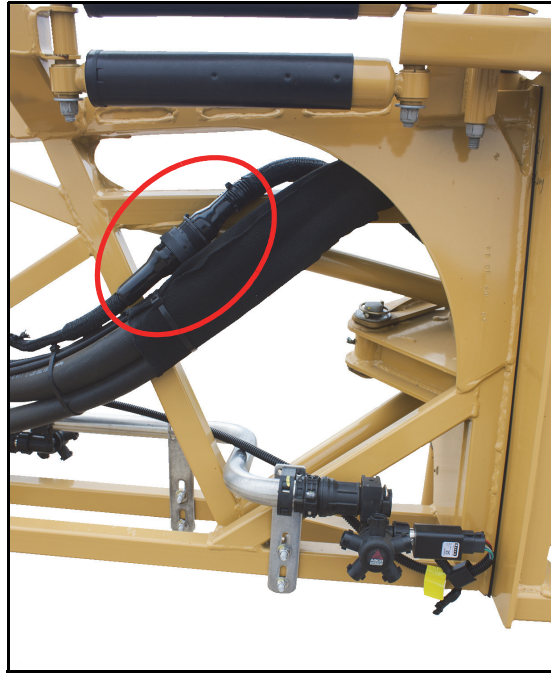

7. Repeat this procedure to route and connect the secondary boom cable on the opposite boom.

**NOTE:** Route and connect the primary and secondary cables before securing the cable with the supplied zip ties.

### PRIMARY BOOM CABLE ROUTING AND CONNECTIONS

**NOTE:** Review the Best Practices and Recommendations section on page 15 before routing or securing the boom cables on the implement. It is recommended not to connect or secure the cable until instructed to do so in the procedure.

1. Locate the large, round connectors on the primary boom cables (refer to the Kit Contents section on page 6). The primary boom cables must be routed such that the connector with female pins is located at the mid-boom fold point of the left or right boom and will connect to the secondary boom cable.

---

**FIGURE 8. Primary Cable Ends**

---



**Male Connector  
To Center Rack/Chassis Connector**



**Female Receptacle  
To Secondary Boom**

2. Starting at the center of the implement, feed the female receptacle end of the primary boom cable through the boom framework along existing cable or plumbing runs and through any existing cable retention devices.
3. Connect the large, round connectors on the primary and secondary boom cables.
4. Adjust the primary and secondary boom cables to ensure sufficient slack around the mid-boom fold point and allow each cable to reach nozzle control valves near the folding point.
5. Secure the primary and secondary connection using the supplied zip ties as necessary to protect the connector from damage during folding and unfolding operations.
6. Once the primary and secondary boom cables are connected, begin connecting the valve tee branches to the nozzle control valves, starting with the valve on the primary boom segment furthest from the center of the implement.
7. At each valve branch, adjust the cable as necessary to provide slack between nozzle control valve connections and use the supplied zip ties to secure the cable at each valve branch. Refer to Figure 6 on page 16. The large, round connector with male pins on the primary boom cable should reach to the center of the implement after all nozzle control valves are connected.
8. Repeat this procedure to route the primary boom cable on the opposite boom.

PRODUCT CONTROLLER II ECU INSTALLATION

BEST PRACTICES AND RECOMMENDATIONS

- Do not connect battery leads until all cables are installed and connected.
- If a protected mounting location is not available on the equipment, mount the Hawkeye product controller II ECU with the connectors facing down toward the ground to help keep moisture from accumulating in the ECU.

ELECTRICAL BOX PREPARATION

1. Locate the electrical box on the right side of the machine, between the axles and remove the cover.

**FIGURE 1. RoGator RG700 Electrical Box Location**

---

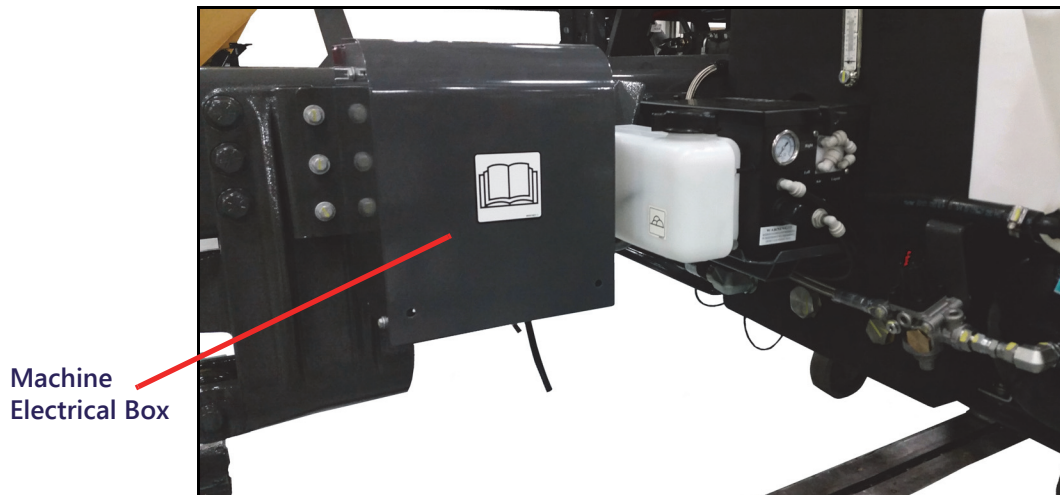

2. Locate the Raven boom/speed sense node and single product control node mounted to the back of the box.

**NOTE:** Due to harness differences, the Hawkeye Nozzle Control System is only compatible with RG700 machines factory-equipped with Raven product control.

FIGURE 2. Raven CAN Node Removal

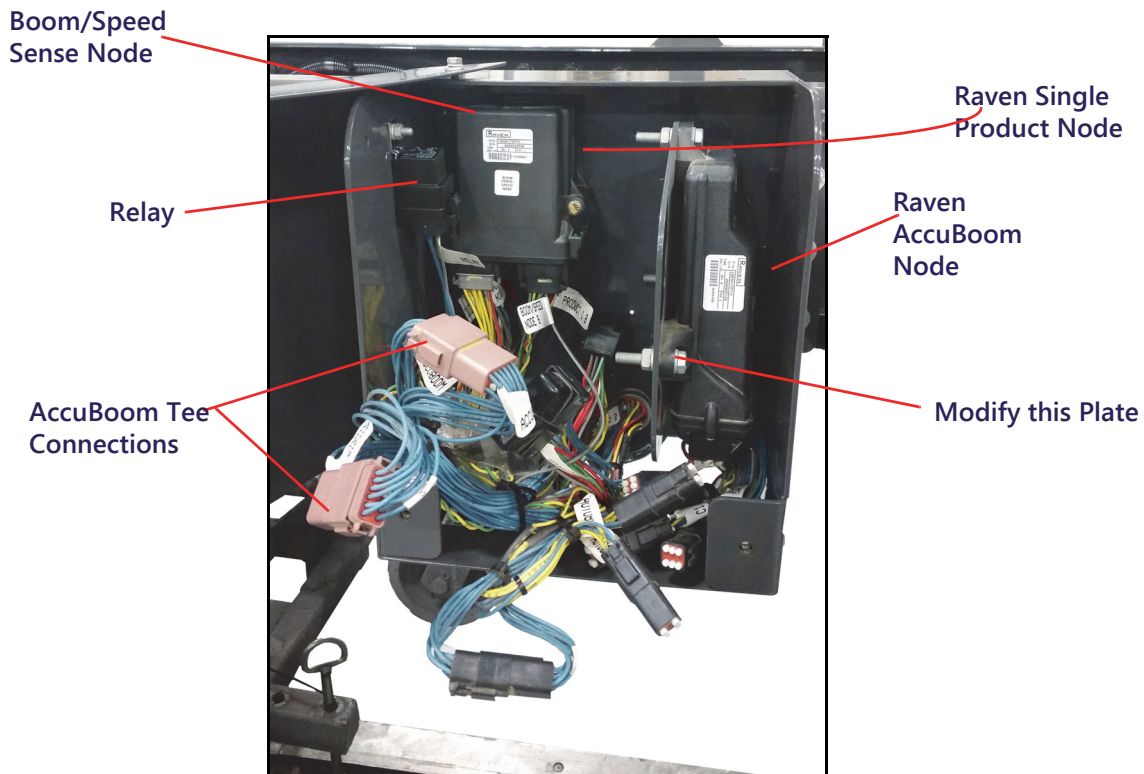

3. Remove the bolts securing the boom/speed node and product node to the back of the electrical box. It may be necessary to remove the relay to access the nodes.
4. Remove the Raven AccuBoom node and mounting plate from the machine electrical box. Retain the mounting plate to mount the new Product Controller II ECU.
5. Tuck the two rectangular node plugs connected to the AccuBoom out of the way at the bottom of the electrical box. These rectangular node plugs are not needed for the Hawkeye system.
6. While the plate is removed, locate the two brown connections (four separate harness connectors) labeled "AccuBoom Tee" in the electrical box.
7. Adjust the harnesses to allow access to these connectors for use during the procedure outlined in the ECU Retrofit Cable Installation section on page 21.

### MOUNTING PLATE PREPARATION AND ECU INSTALLATION

1. Using the Product Controller II ECU as a template, mark the mounting plate for the new ECU mounting bolt pattern. It may be possible to use some existing hoses in the plate.

**NOTE:** The Product Controller II ECU should be mounted with the cable connectors pointing toward the bottom of the electrical box. Position the ECU parallel with a straight edge of the mounting plate. Keep in mind the electrical box cover when positioning and marking the plate for mounting the Product Controller II ECU.

2. Use a 5/16" bit to drill the mounting plate.
3. Reuse the hardware from the boom/speed node or single product node to mount the ISO Boom/Speed Sense ECU.
4. Use the supplied 1/4" bolts, hex nuts, and flat washers to mount the Product Controller II ECU to the mounting plate.



5. Reinstall the node mounting plate into the electrical box and use a socket, socket extension, and existing hardware to secure the plate in place.

## ECU RETROFIT CABLE INSTALLATION

**NOTE:** Refer to the system diagram for connection details.

1. Locate the large, round receptacle on the Hawkeye ECU cable (P/N 115-7303-190).
2. Feed the receptacle through the rectangular opening in the bottom of the ECU box.
3. Route the opposite end of the ECU cable to the product controller II ECU.
4. Insert the four Product Controller II ECU connectors (gray, green, brown, and black) into the Product Controller II ECU as indicated below.

**FIGURE 3. Product Controller II ECU Connections**

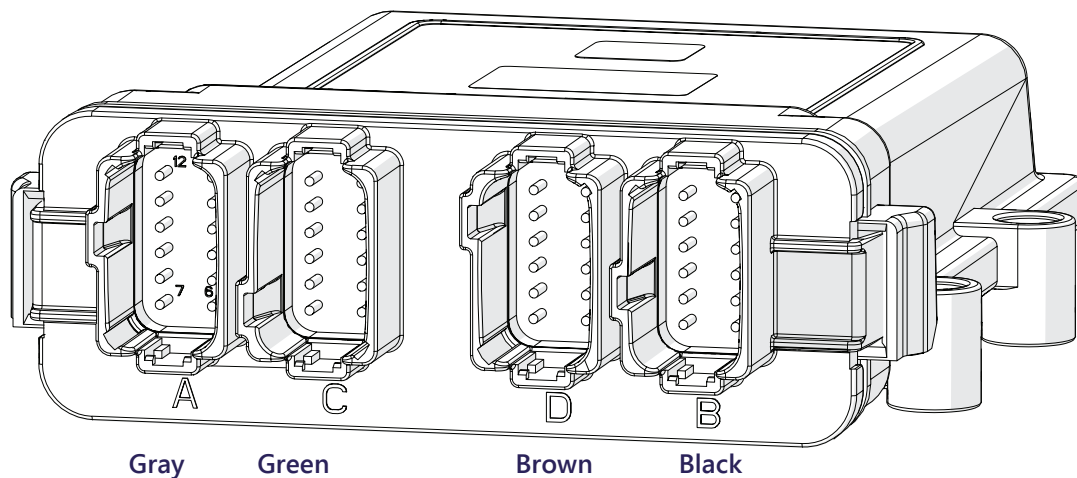

5. Locate the branch on the ECU cable with the two triangular ISOBUS connectors, one plug and one receptacle.
6. Locate the 3-Pin ISObus connection in the ECU box labeled "CAN 4 Terminator".

**FIGURE 4. CAN 4 Terminator**

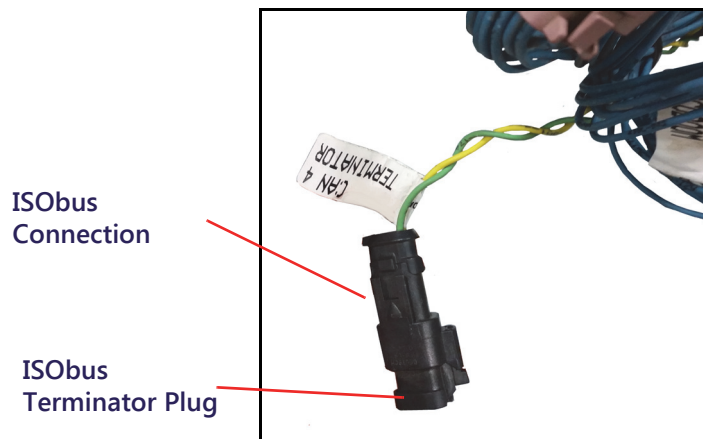

7. Remove the ISObus terminator plug from the 3-pin connection and plug it into the open 3-pin receptacle of the ECU cable.

8. Connect the 3-pin plug connection of the ECU cable into the receptacle where the 3-pin terminator was connected.

#### SINGLE PRODUCT NODE REMOVAL AND ECU CONNECTION

1. Locate the gray and black connectors on the existing single product node and the gray and black receptacles labeled "Single Product Node" on the Hawkeye ECU cable (P/N 115-7303-190).
2. Disconnect the black plug from the single product node and connect to the black receptacle on the ECU cable labeled "Single Product Node".
3. Disconnect the gray plug from the single product node and connect to the gray receptacle on the ECU cable labeled "Single Product Node". The single product node will not be reused with the Hawkeye system and may be set aside.

#### BOOM/SPEED NODE REMOVAL AND ECU CONNECTION

1. Locate the gray and black connectors on the existing boom/speed node and the gray receptacle on the Hawkeye Boom Sense retrofit cable (P/N 115-7303-084).
2. Disconnect the gray plug from the boom/speed node and connect to the gray receptacle on the Hawkeye Boom Sense retrofit cable labeled "Single Product Node".
3. Insert the remaining gray plug on the retrofit cable into the provided ISO boom/speed ECU (P/N 063-0173-635).
4. Locate the remaining black 12-pin plug and 12-pin receptacle on the Hawkeye ECU cable (P/N 115-7303-190). These are located adjacent to the 3-pin triangular ISObus connectors.
5. Disconnect the black connector from the boom/speed node and connect to the black receptacle of the Hawkeye ECU cable (P/N 115-7303-190). The existing Boom/Speed node will not be used with the Hawkeye system.
6. Insert the remaining black plug on the Hawkeye ECU cable into the ISO Boom/Speed ECU.

#### FINAL HAWKEYE ECU CABLE CONNECTIONS

1. Disconnect the two brown "AccuBoom Tee" connections of the machine's harness located earlier in the installation process.
2. While looking at the back side of each of the existing brown, 12-pin receptacles, locate the wires in the Pin 1 sockets of each connector. There is text printed directly on the wires. One of the receptacle's Pin 1 wires will read "730L-1-119 LTBL-16 Section 1."

**FIGURE 5. Pin 1**

---

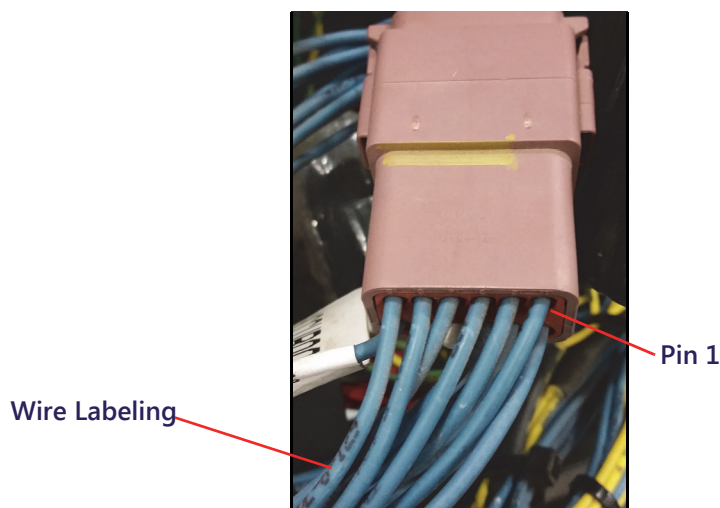

3. Connect the receptacle identified step 2 in to the brown 12-pin plug on the retrofit cable (P/N 115-7303-190) labeled "Boom Valves."
4. While looking at the back of the two existing 12-pin brown plugs, identify Pin 1 of each connector. One of the connectors should have a blue wire in Pin 1 labeled "730L-1-120 LTBL-16 Section 1."
5. Connect the plug to the brown receptacle of the ECU Cable (P/N 115-7303-190) labeled boom valves.

**NOTE:** The remaining 12-pin plug and receptacle lead to the AccuBoom node which is no longer used with the Hawkeye system. These connectors will not be used. Connect this plug and receptacle together to protect the pins from corrosion.

**NOTE:** After Hawkeye system installation is complete, if the boom switches or valves do not operate correctly, it is possible the wrong connectors were identified above. Switching the connectors should correct the issue.

6. Tuck cables back into the electrical box and replace the cover.



### CHASSIS CABLE ROUTING AND CONNECTION

#### BEST PRACTICES AND RECOMMENDATIONS

- Do not connect battery leads until all cables are installed and connected.
- Route chassis cabling along existing cabling or plumbing to help avoid pinch points or stretching the cable during normal equipment operation.

#### ELECTRICAL BOX CONNECTION

1. Locate the single, round connector on the supplied chassis cable (P/N 115-7303-189).
2. Route this connector to the electrical box and connect to the round receptacle of the Hawkeye retrofit cable that was previously routed through the rectangular opening in the bottom of the electrical box (review the ECU Retrofit Cable Installation section on page 21).

**FIGURE 1. Chassis Cable Electrical Box Connection**

---



#### CENTER RACK ROUTING AND BOOM CABLE CONNECTIONS

1. Route the round connectors labeled "left boom" and "right boom" toward the center rack of the machine.
2. Use the provided zip ties to secure the chassis cable to the undercarriage as necessary to avoid snagging the cable during machine operation.
3. At the rear of the applicator tank, route the chassis cable to follow the chemical supply lines underneath the rear catwalk and then up through the center rack framework. Following the supply lines will help to ensure adequate slack for operating the center rack during field operations and when folding and unfolding the booms.

FIGURE 2. Chassis Cable Center Rack Routing

Chassis  
Cable

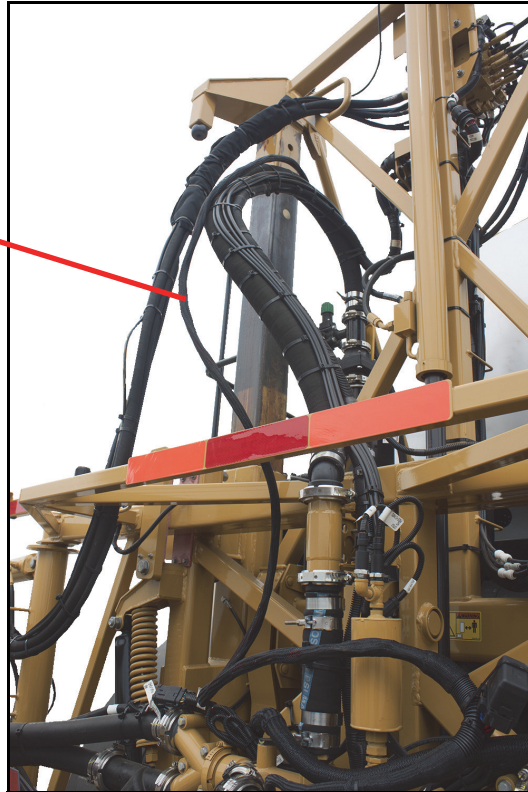

4. Use zip ties to secure the chassis cable to existing system lines to keep the cable from being damaged during normal equipment operation.
5. Connect the round connectors to the left and right boom cables at the center rack as appropriate. Orient the boom cable connectors horizontally to avoid moisture collecting the rubber boots of the round connectors.
6. Use supplied zip ties to secure any excess cabling on the center rack framework.

### BATTERY COMPARTMENT AND CONNECTIONS

1. Open the hood of the machine to access the battery compartment.

FIGURE 3. RoGator RG700 Battery Compartment

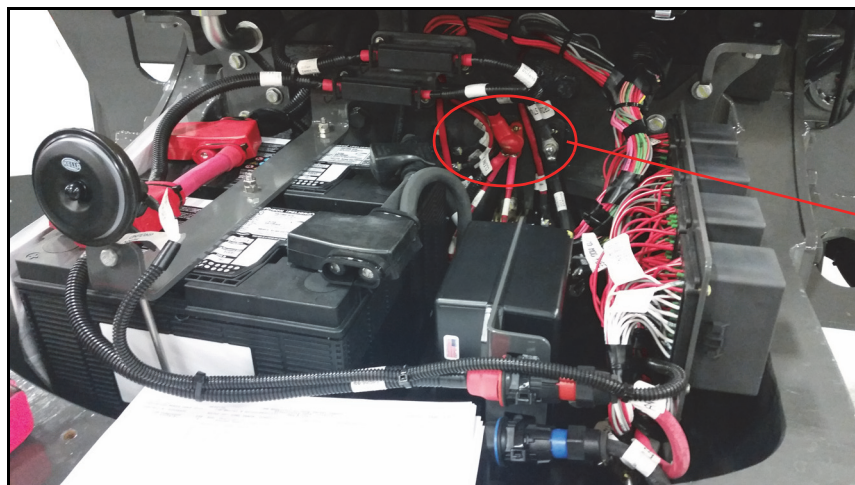

Positive and  
Negative  
Power  
Connections

2. Follow the right hand frame rail to route the battery leads on the chassis cable branch into the battery compartment.
3. Use the provided zip ties to secure the chassis cable to the undercarriage as necessary to avoid snagging the cable during machine operation.
4. Verify the battery disconnect switch is disconnected.
5. Remove the nut from the Positive) power connection shown below.
6. Place the Positive Hawkeye power wire over the stud and replace the retaining nut.
7. Remove the nut from the Negative) power connection shown below.
8. Place the Negative Hawkeye power wire over the stud and replace the retaining nut.
9. After system installation is complete, turn the battery disconnect switch on.

**FIGURE 4. Battery Box Connections**



## SYSTEM DIAGRAMS

Diagrams start on the next page.

FIGURE 5. System Diagram (Page 1)

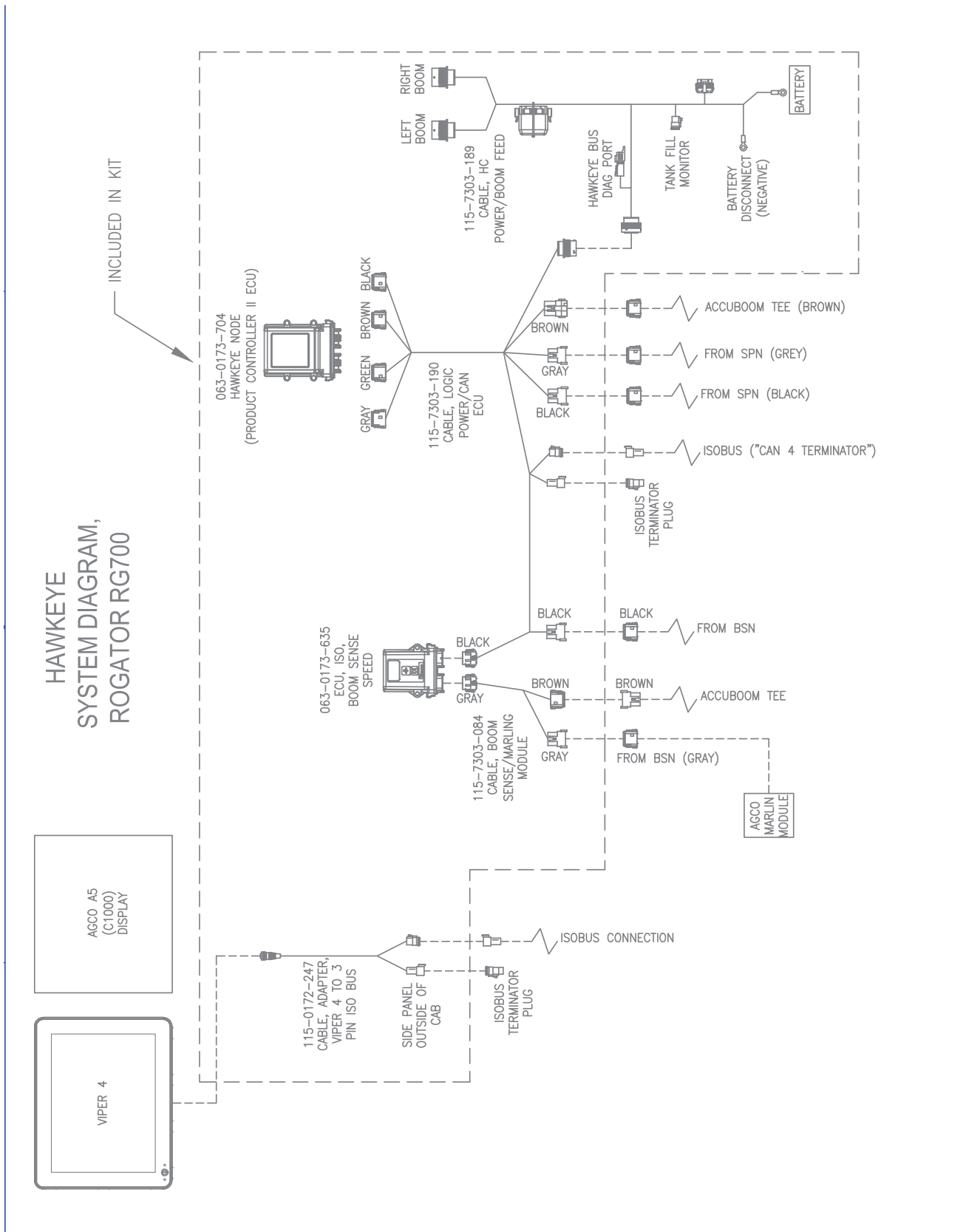
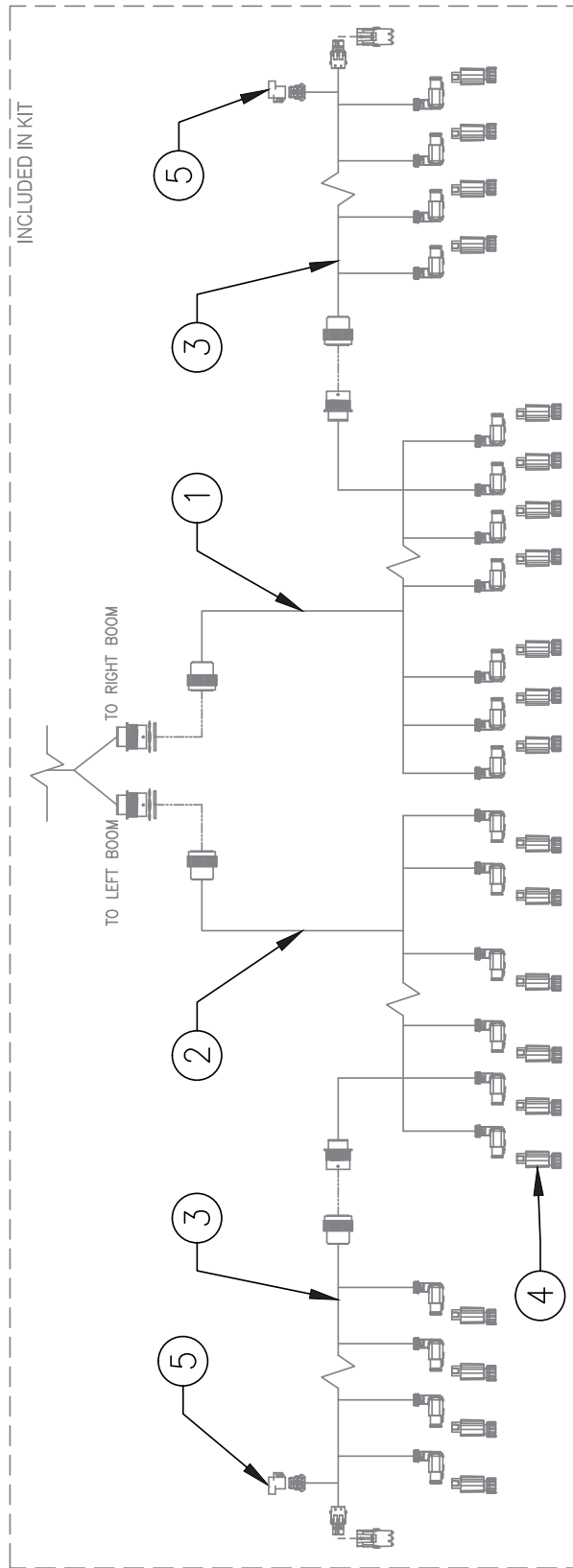



FIGURE 6. System Diagram (Page 2)

NOTES:  
 1. CABLES SHORTENED FOR GRAPHICAL PURPOSES

| ITEM | DESCRIPTION                  | RG700<br>60/90° COMBO BOOM<br>20' SPACING<br>IN KIT P/N: 117-1005-026 | RG700<br>60/80° COMBO BOOM<br>20' SPACING<br>IN KIT P/N: 117-1005-027 | RG700<br>60/90° COMBO BOOM<br>15' SPACING<br>IN KIT P/N: 117-1005-028 | RG700<br>60/80° COMBO BOOM<br>15' SPACING<br>IN KIT P/N: 117-1005-029 |
|------|------------------------------|---|---|---|---|
| 1    | CABLE, RIGHT PRIMARY         | 115-7303-191  | 115-7303-191  | 115-7303-133  | 115-7303-133  |
| 2    | CABLE, LEFT PRIMARY          | 115-7303-191  | 115-7303-191  | 115-7303-132  | 115-7303-132  |
| 3    | CABLE, SECONDARY<br>(QTY: 2) | 115-7303-192  | 115-7303-192  | 115-7303-134  | 115-7303-127  |
| 4    | ARAG / HYPRO HAWKEYE VALVE   | 063-0173-673<br>(QTY: 54)   | 063-0173-673<br>(QTY: 48)   | 063-0173-673<br>(QTY: 71)   | 063-0173-673<br>(QTY: 63)   |
| 5    | CAN TERMINATOR<br>(QTY: 2)   | 063-0172-964  | 063-0172-964  | 063-0172-964  | 063-0172-964  |





**A**

Contact a local equipment or Raven dealer for additional assistance with any adapter cables required for connecting the Hawkeye nozzle control system to the virtual terminal (VT).

**VIPER 4 ISOBUS ADAPTER CABLE**

**NOTE:** The ISOBUS adapter cable (P/N 115-0172-247) is required for a ROS device to interface with the Hawkeye nozzle control system. Refer to the Installation Manual provided with the ROS device for additional assistance with installing a Raven display.

**NOTE:** 2016 and newer machines with an existing Viper 4 field computer may already have the ISObus connected to the Viper 4.

Look for a cable connected to Port 5 on the back of the V4 to verify. If present, the ISObus adapter cable (P/N 115-0172-247) will not be used. There may be two 2-pin Deutsch connectors on the existing console cable that need to be connected together to finish connecting the V4 to the ISObus.

1. Locate the electrical panel outside of the right hand side of the cab.

**FIGURE 1. RG700 Cab Compartment**



2. Remove the panel cover to access the ISOBUS terminator and connections.
3. Locate the ISObus terminator connection.

FIGURE 2. Upper Panel Right of the Operator Seat

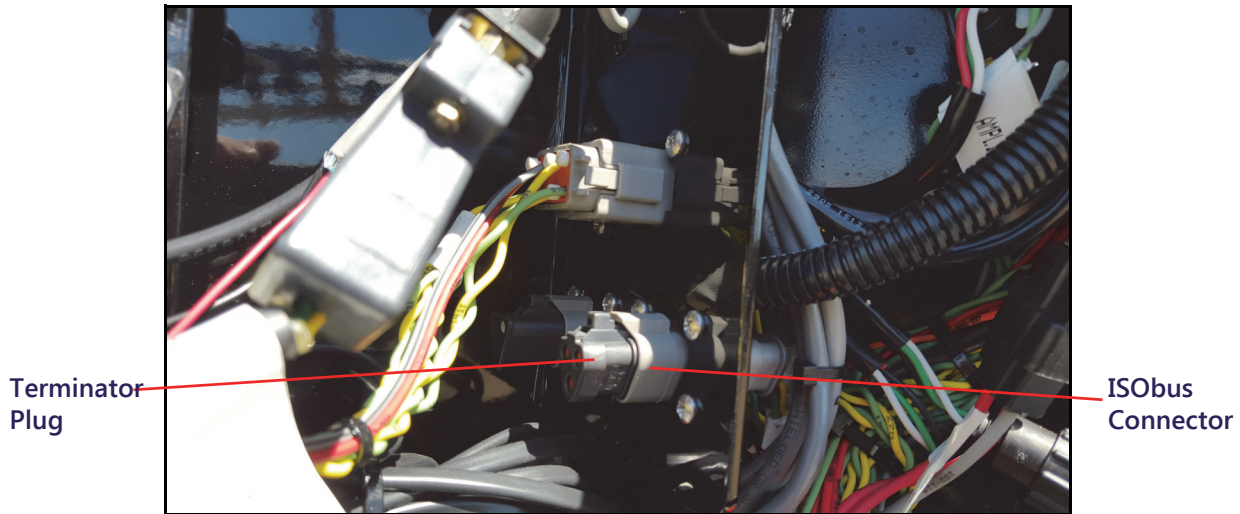

4. Disconnect the ISO terminator from the 3-pin connector.
5. Route the ISObus adapter cable (P/N 115-0172-247) from inside the cab through the firewall.
6. Plug in the 3-pin ISObus connector to the connectors to allow the ROS device to interface with the machine ISOBUS and the Raven Hawkeye nozzle control system.
7. Plug the ISO terminator plug on to the second connector.
8. Route the adapter cable to the back of the ROS device and connect to the receptacle labeled "5."
9. Disable the Task Controller on the C1000 monitor before turning on the ROS.

---

## POWER AND ECU HARNESS MAINTENANCE

1. Disconnect the ECU harness connector and inspect for signs of moisture or corrosion.
2. If moisture or corrosion is detected, use Deoxit D5, brushes, and compressed air to clean and dry the connector.
3. When clean, apply a coating of Corrosion X HD to the connector mating surfaces and contacts.
4. Reattach the connectors.

---

## HAWKEYE BOOM HARNESS CONNECTOR MAINTENANCE

Prior to connecting the Hawkeye boom cable to the Hawkeye Nozzle Control Valves (NCV), perform the following steps to all 6-pin NCV connectors and 19-pin circular connectors between the boom cables and ECU cable connections to ensure high quality connections:

1. Verify the NCV connectors and the accompanying boom cable connectors are free of moisture, contamination, or oxidation. Oxidation will appear as a dry, white coating on the contacts. If any connectors show signs of moisture, contamination, or oxidation, perform Step 2 - Step 6. If this is a new installation, skip to Step 7. All components listed below can be ordered in the Hawkeye NCV Connection Maintenance Kit (P/N 117-0171-692).
2. Spray the connection with a deoxidizing agent (DeoxIT D5 is recommended (P/N 222-4001-006)).

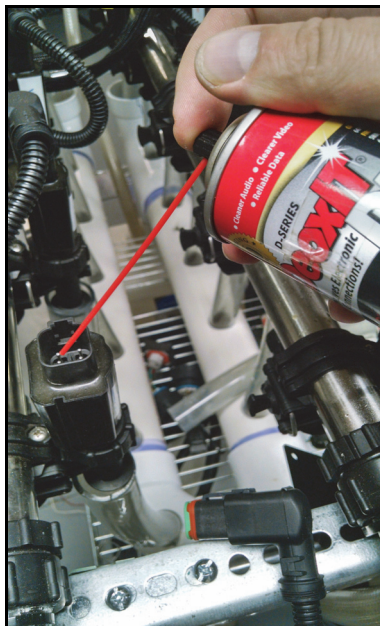

3. Clean contacts with a small wire brush (P/N 321-0000-477).

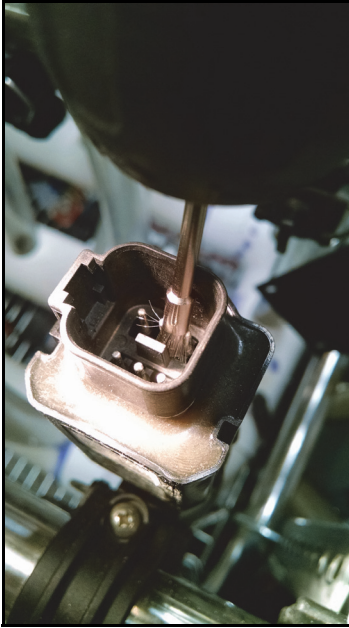

4. Spray the contacts again with the deoxidizing agent. This will rinse out debris.
5. Remove all residue of deoxidizing agent from the connection. Not removing deoxidizing agent can damage the connector seal.
6. Dry out the connection with dry, compressed air. Dust Off Electronics Duster (P/N 222-4001-007) is recommended however, if unavailable, alternate compressed air sources can be used. If using compressed air from a large volume air compressor, be sure the lines are free of moisture.



7. If not already applied, apply a single short burst of corrosion inhibitor (Corrosion X HD (Raven P/N 222-0000-020 or available from <http://www.corrosionx.com/corrosionx-heavy-duty.html>)) into the NCV connection. Be sure the corrosion inhibitor has coated the NCV contacts and recessed portions of the connector.

**NOTE:** To determine if corrosion inhibitor has been applied, inspect for a thick liquid in the bottom of the connector (as shown in the Corrosion Inhibitor Applied image below).

**NCV Connector**

Spray in  
Void  
Between  
Pins

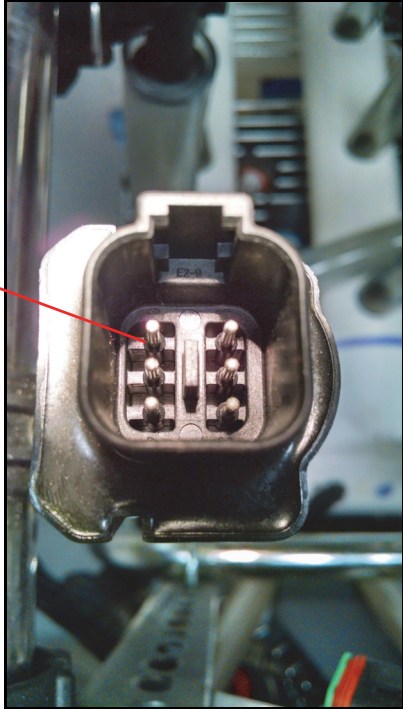

**Applying Corrosion Inhibitor**

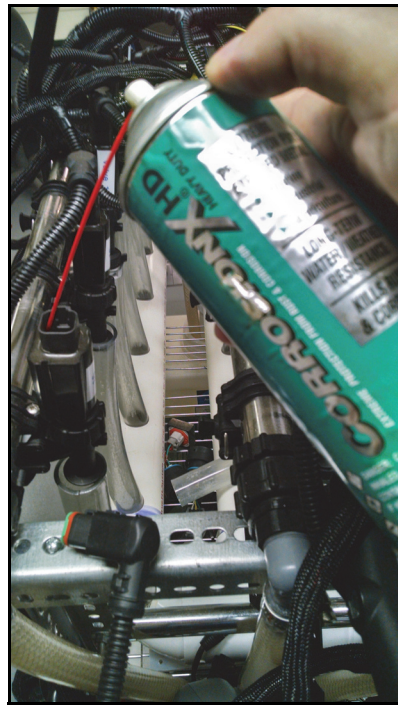

**Corrosion Inhibitor Applied**

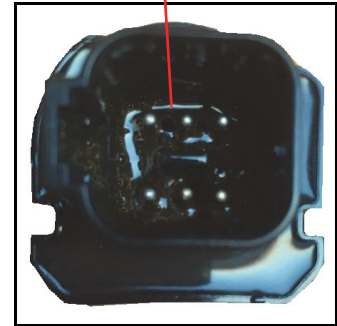





# RAVEN

## Limited Warranty

---

### ***What Does this Warranty Cover?***

This warranty covers all defects in workmanship or materials in your Raven Applied Technology Division product under normal use, maintenance, and service when used for intended purpose.

### ***How Long is the Coverage Period?***

Raven Applied Technology products are covered by this warranty for 12 months from the date of retail sale. In no case will the Limited Warranty period exceed 24 months from the date the product was issued by Raven Industries Applied Technology Division. This warranty coverage applies only to the original owner and is non-transferable.

### ***How Can I Get Service?***

Bring the defective part and proof of purchase to your Raven dealer. If the dealer approves the warranty claim, the dealer will process the claim and send it to Raven Industries for final approval. The freight cost to Raven Industries will be the customer's responsibility. The Return Materials Authorization (RMA) number must appear on the box and all documentation (including proof of purchase) must be included inside the box to be sent to Raven Industries.

### ***What Will Raven Industries Do?***

Upon confirmation of the warranty claim, Raven Industries will (at our discretion) repair or replace the defective product and pay for the standard return freight, regardless of the inbound shipping method. Expedited freight is available at the customer's expense.

### ***What is not Covered by this Warranty?***

Raven Industries will not assume any expense or liability for repairs made outside our facilities without written consent. Raven Industries is not responsible for damage to any associated equipment or products and will not be liable for loss of profit, labor, or other damages. The obligation of this warranty is in lieu of all other warranties, expressed or implied, and no person or organization is authorized to assume any liability for Raven Industries.

**Damages caused by normal wear and tear, misuse, abuse, neglect, accident, or improper installation and maintenance are not covered by this warranty.**



## Extended Warranty

### ***What Does this Warranty Cover?***

This warranty covers all defects in workmanship or materials in your Raven Applied Technology Division product under normal use, maintenance, and service when used for intended purpose.

### ***Do I Need to Register My Product to Qualify for the Extended Warranty?***

Yes. Products/systems must be registered within 30 days of retail sale to receive coverage under the Extended Warranty. If the component does not have a serial tag, the kit it came in must be registered instead.

### ***Where Can I Register My Product for the Extended Warranty?***

To register, go online to [www.ravenhelp.com](http://www.ravenhelp.com) and select Product Registration.

### ***How Long is the Extended Warranty Coverage Period?***

Raven Applied Technology products that have been registered online are covered for an additional 12 months beyond the Limited Warranty for a total coverage period of 24 months from the date of retail sale. In no case will the Extended Warranty period exceed 36 months from the date the product was issued by Raven Industries Applied Technology Division. This Extended Warranty coverage applies only to the original owner and is non-transferable.

### ***How Can I Get Service?***

Bring the defective part and proof of purchase to your Raven dealer. If the dealer approves the warranty claim, the dealer will process the claim and send it to Raven Industries for final approval. The freight cost to Raven Industries will be the customer's responsibility. The Return Materials Authorization (RMA) number must appear on the box and all documentation (including proof of purchase) must be included inside the box to be sent to Raven Industries. In addition, the words "Extended Warranty" must appear on the box and all documentation if the failure is between 12 and 24 months from the retail sale.

### ***What Will Raven Industries Do?***

Upon confirmation of the product's registration for the Extended Warranty and the claim itself, Raven Industries will (at our discretion) repair or replace the defective product and pay for the standard return freight, regardless of the inbound shipping method. Expedited freight is available at the customer's expense.

### ***What is Not Covered by the Extended Warranty?***

Raven Industries will not assume any expense or liability for repairs made outside our facilities without written consent. Raven Industries is not responsible for damage to any associated equipment or products and will not be liable for loss of profit, labor, or other damages. Cables, hoses, software enhancements, and remanufactured items are not covered by this Extended Warranty. The obligation of this warranty is in lieu of all other warranties, expressed or implied, and no person or organization is authorized to assume any liability for Raven Industries.

**Damages caused by normal wear and tear, misuse, abuse, neglect, accident, or improper installation and maintenance are not covered by this warranty.**