

**DCS
CABLE
DRAWING
BOOK**

CABLE, 30' DCS 310 CONSOLE 115-0159-878 (REV. D)

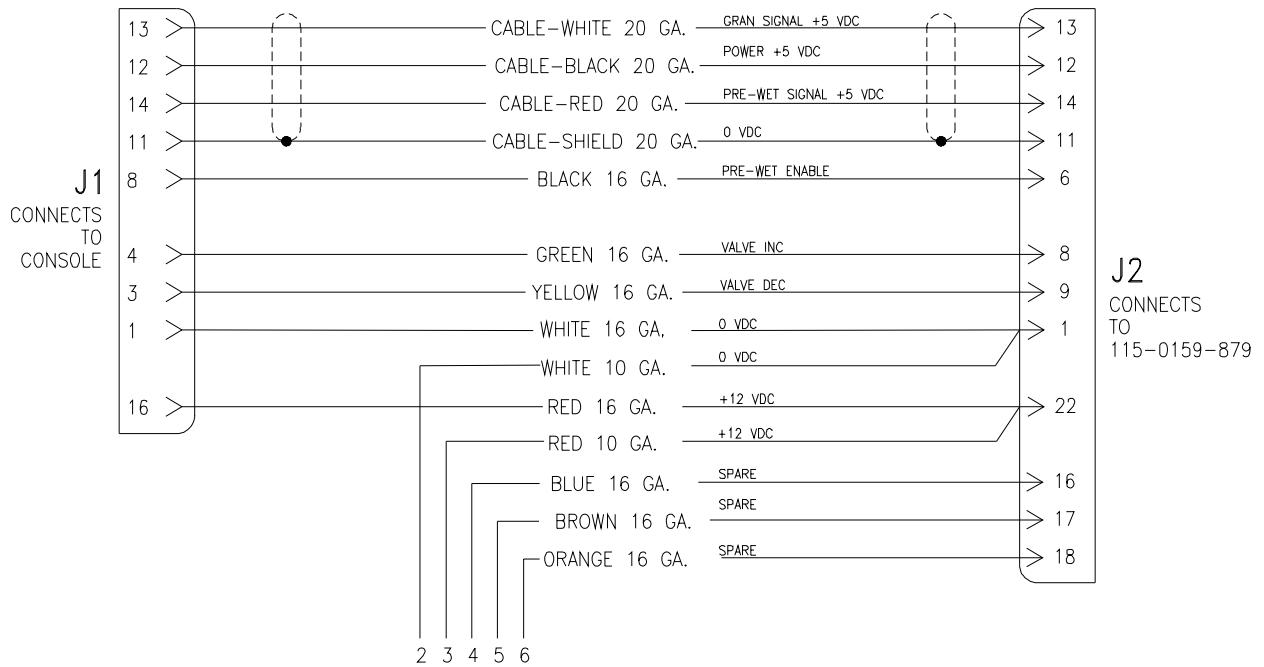

CABLE, 16' DCS 310 PRODUCT 115-0159-879

(REV. NONE)

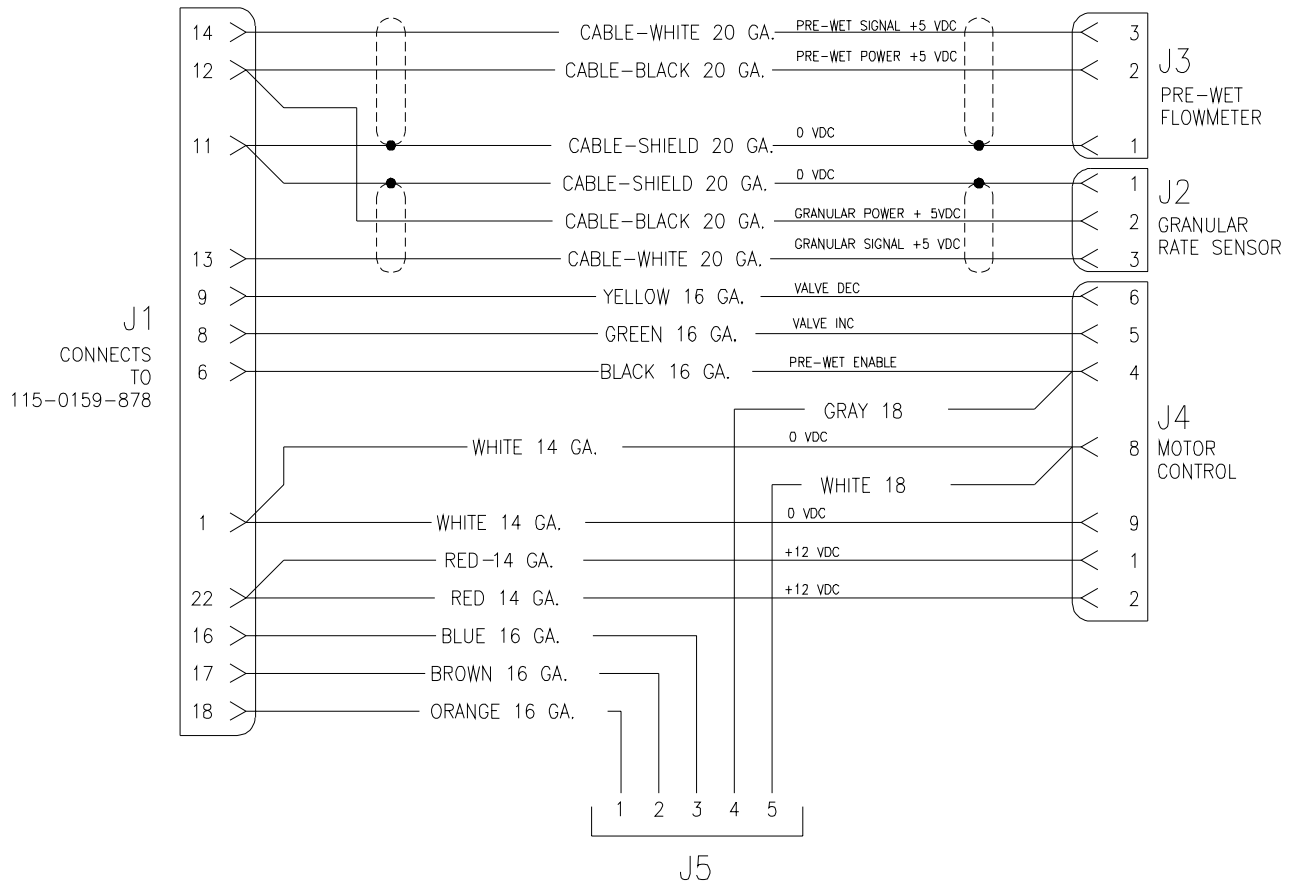

CABLE, PRODUCT, DCS 700 115-0159-925

(REV. A)

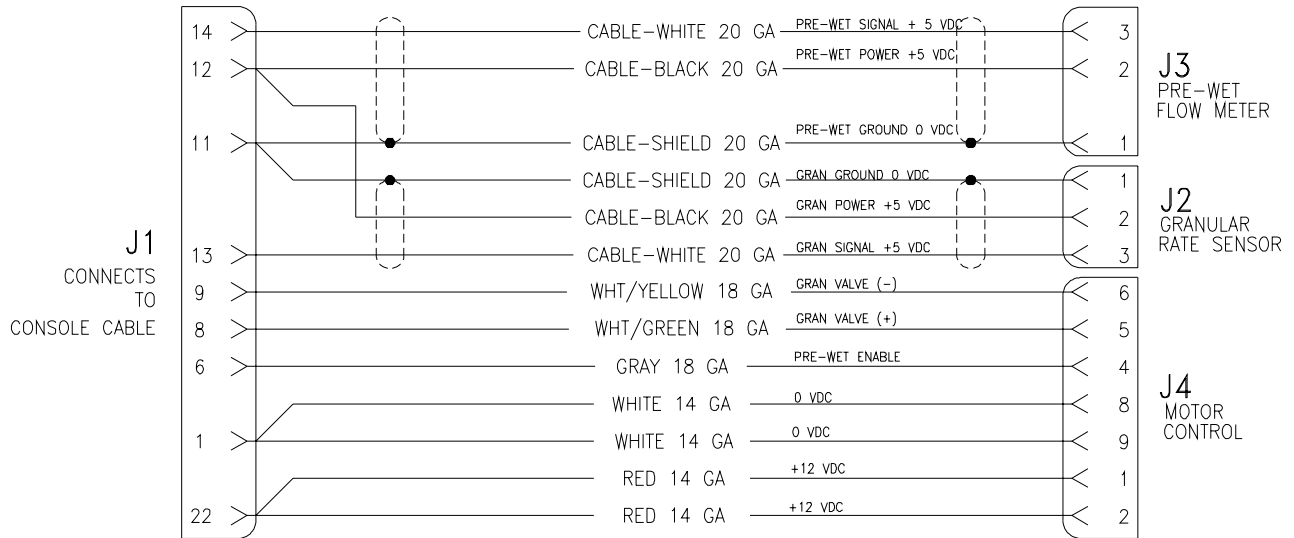

**CABLE,
24' DCS 300 ENCODER,
EXENSION**

115-0159-946

(REV. NONE)

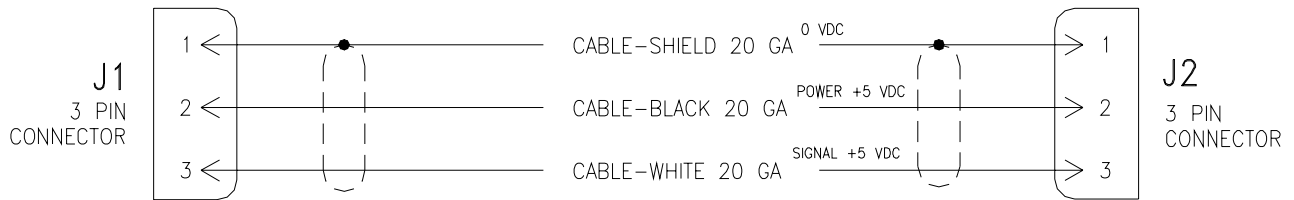

CABLE, 15' SPEED INTERFACE 115-0159-953

(REV. A)

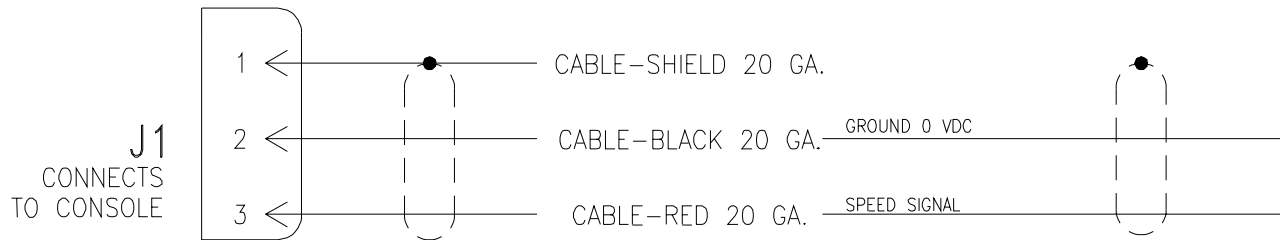

CABLE, PRODUCT, ANTI-ICE

115-0159-955 - 10' (REV. A)
115-0171-093 - 50' (REV. NONE)

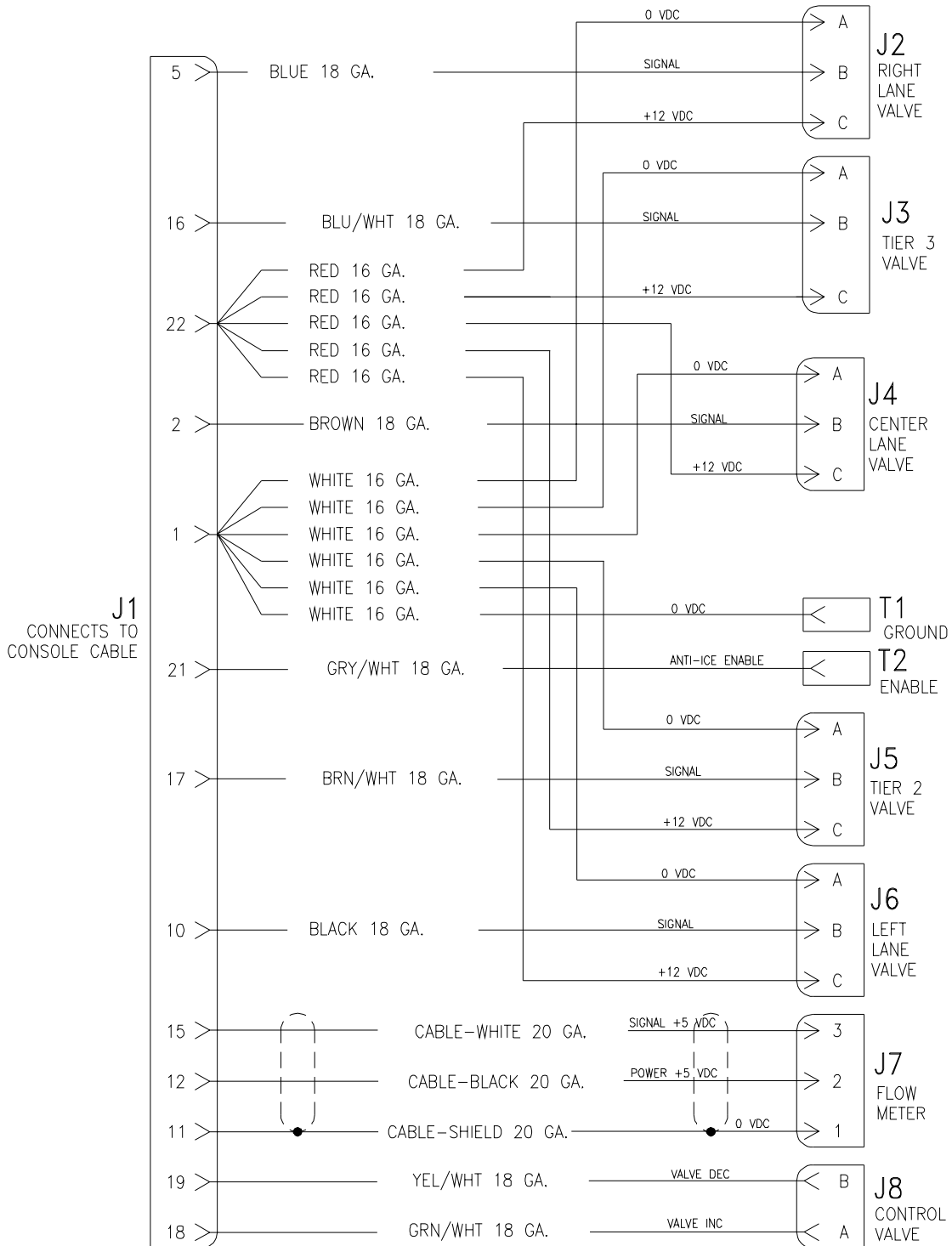

CABLE, 9' PRODUCT, GRANULAR 115-0159-956 (REV. NONE)

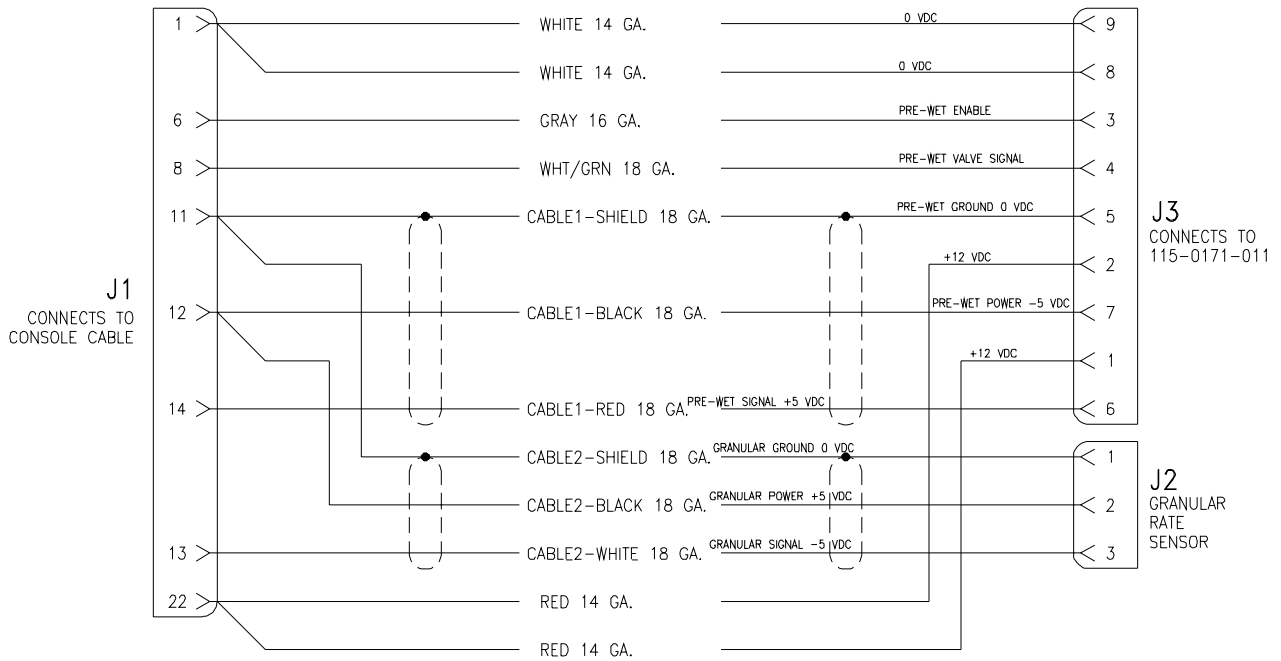

CABLE, CONSOLE, DLA336/DCS700/DCS710 115-0159-957 (REV. C)

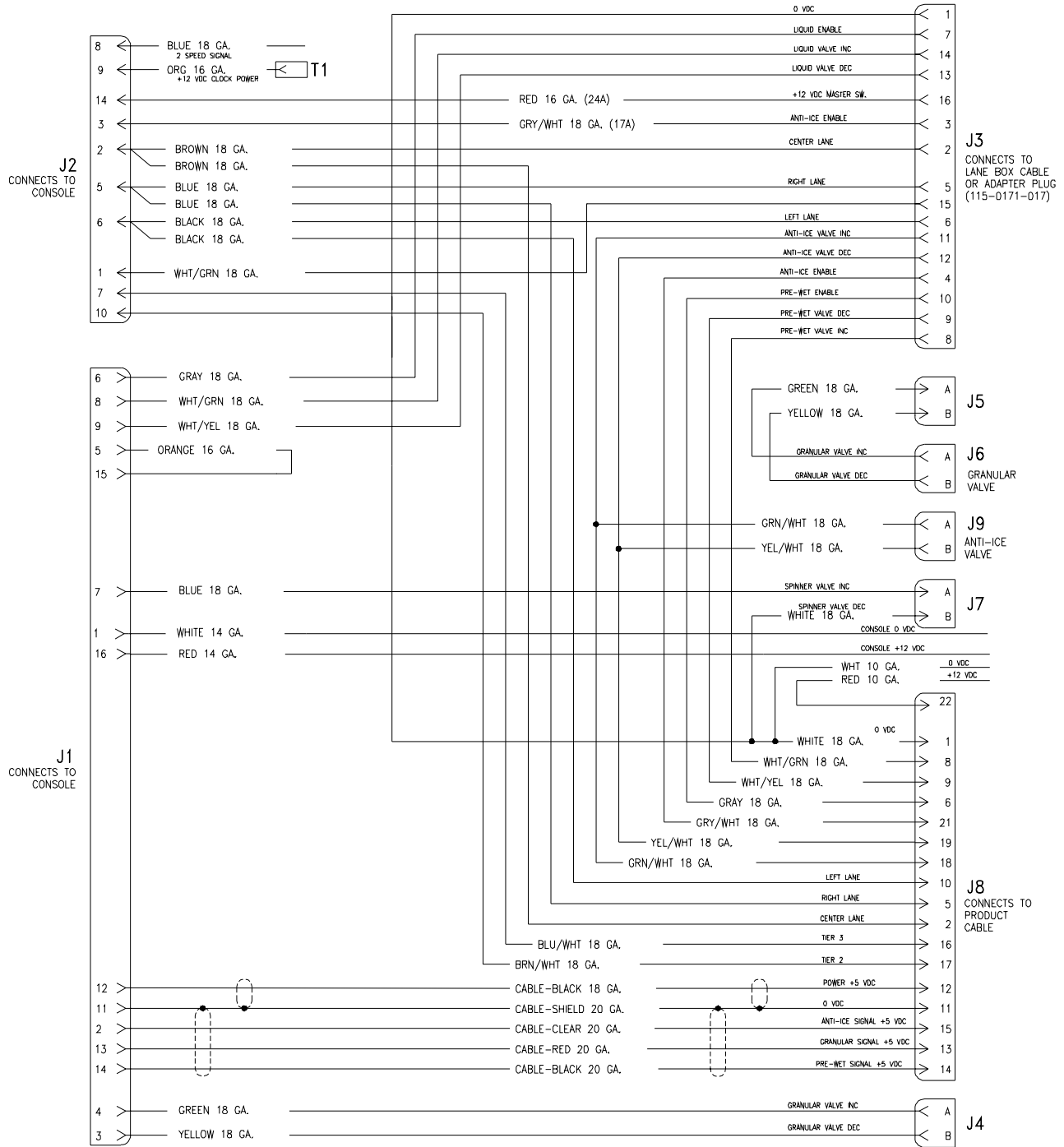

CABLE, CONSOLE, DCS 700, IOWA RETROFIT 115-0159-959 (REV. A)

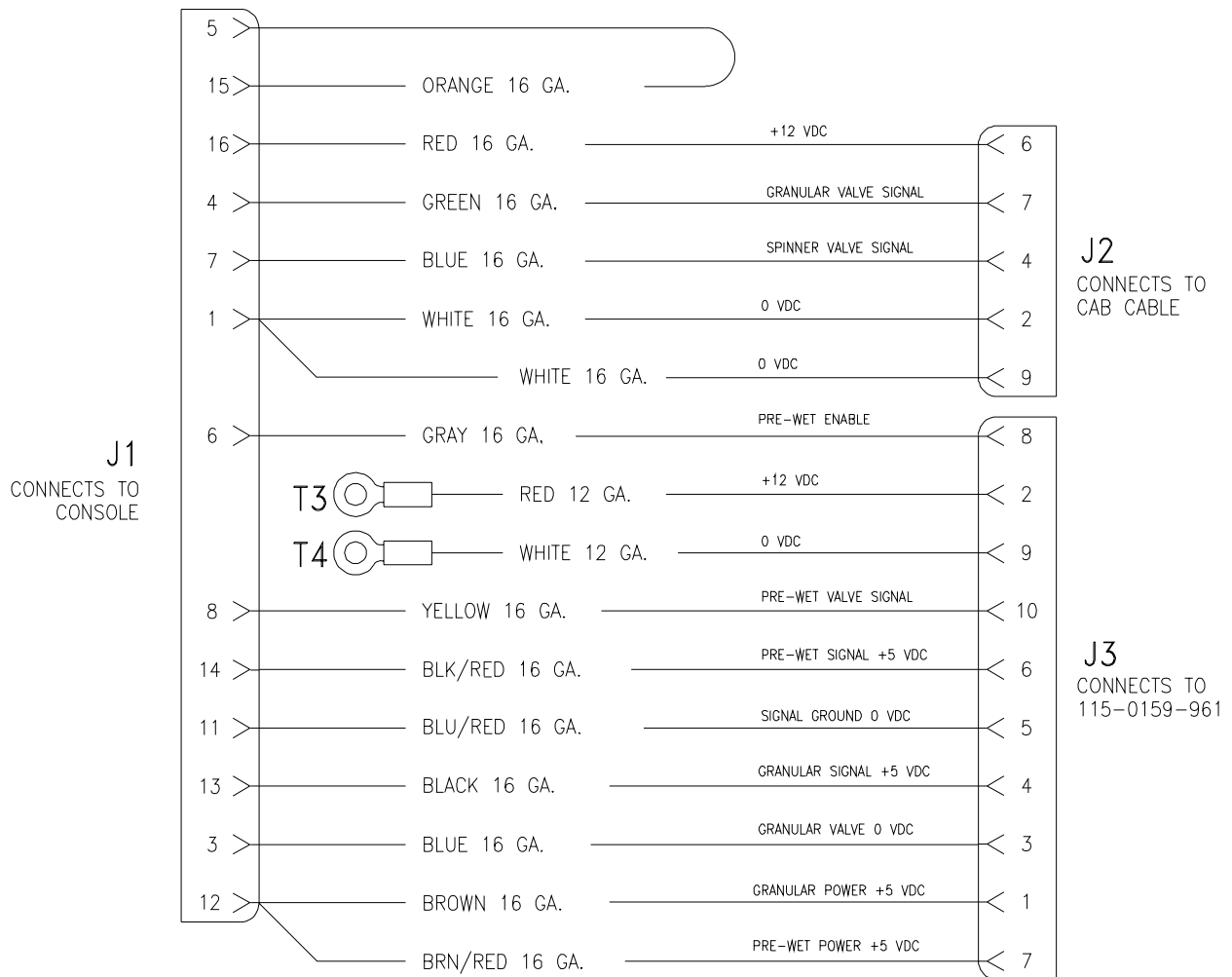

CABLE, PRODUCT, DCS 700, IOWA 115-0159-960 (REV. C)

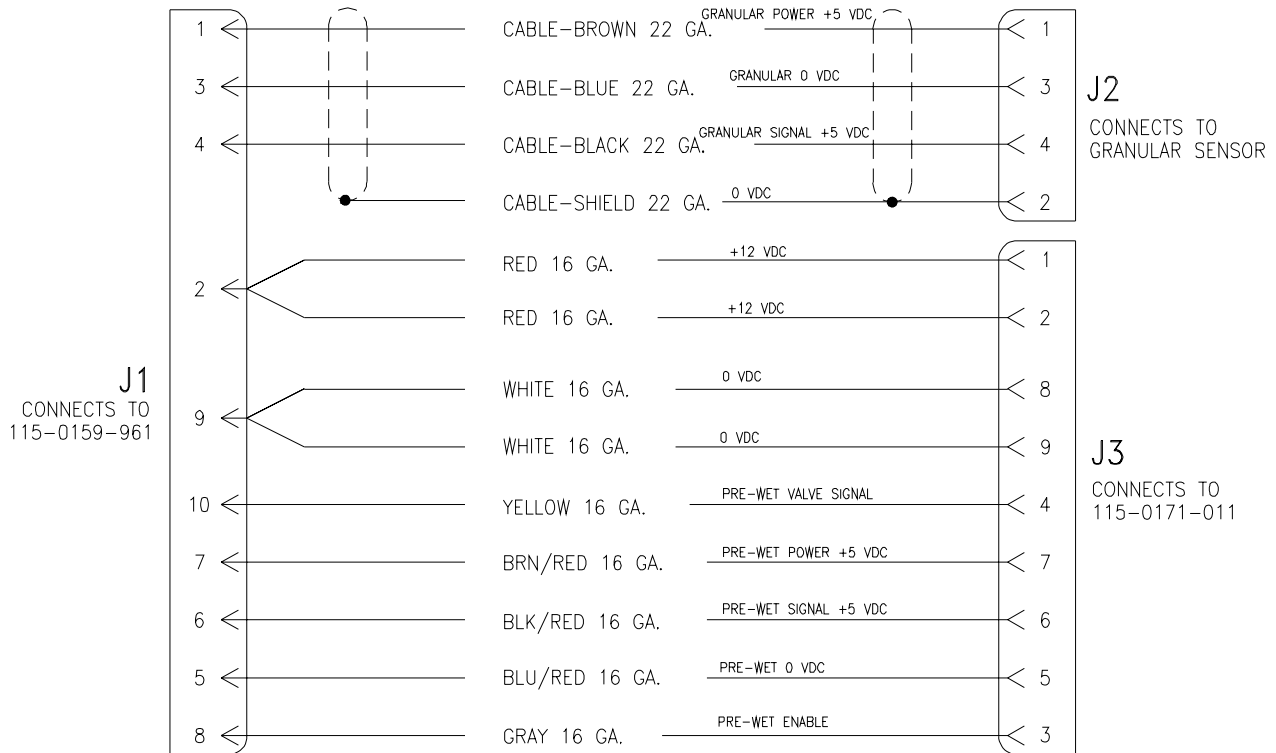

**CABLE,
EXTENSION, IOWA
115-0159-961
(REV. NONE)**

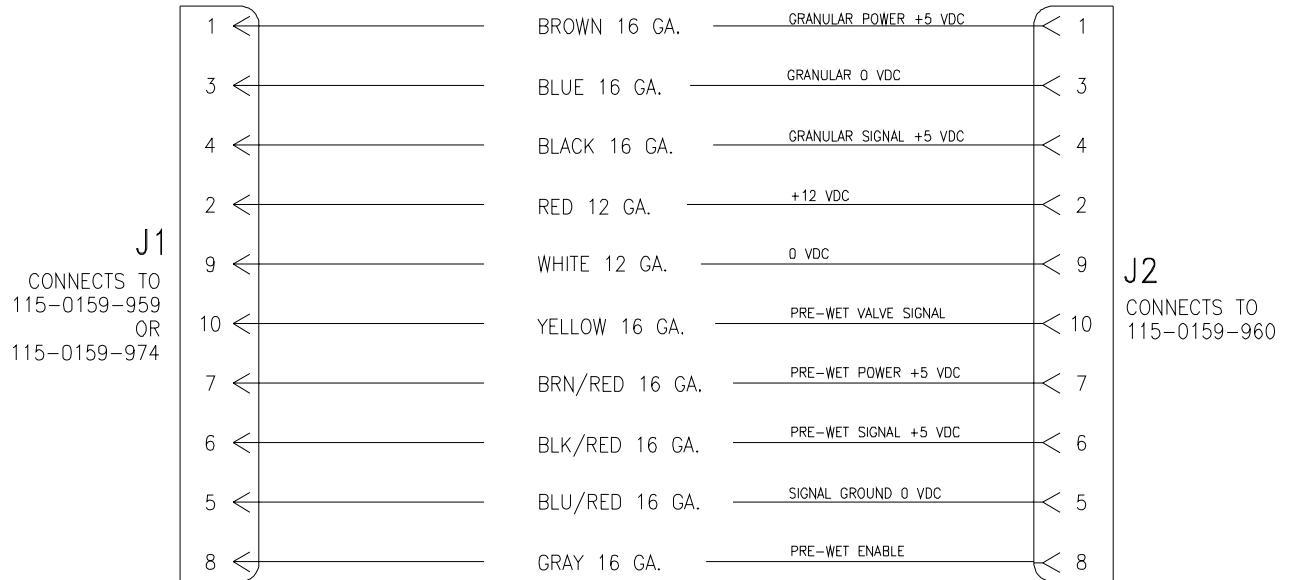

CABLE, 31', CONSOLE 115-0159-971 (REV. C)

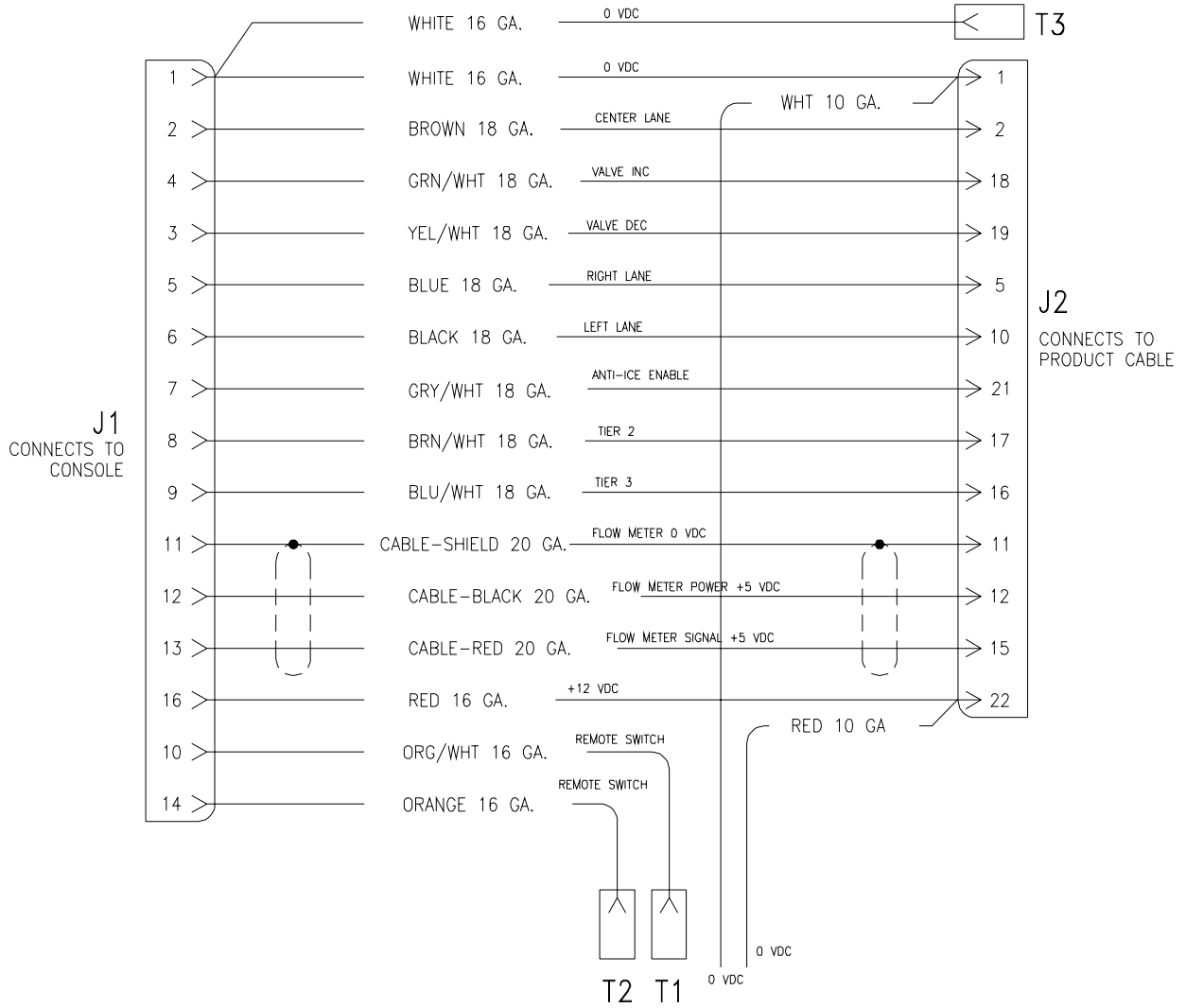

**CABLE,
CONSOLE, DCS 700, IOWA
115-0159-973
(REV. NONE)**

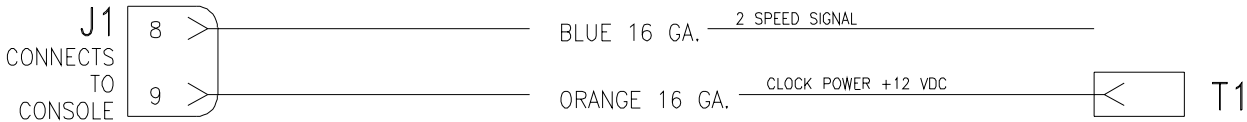

CABLE, CONSOLE CAB, DCS 700, IOWA 115-0159-974 (REV. A)

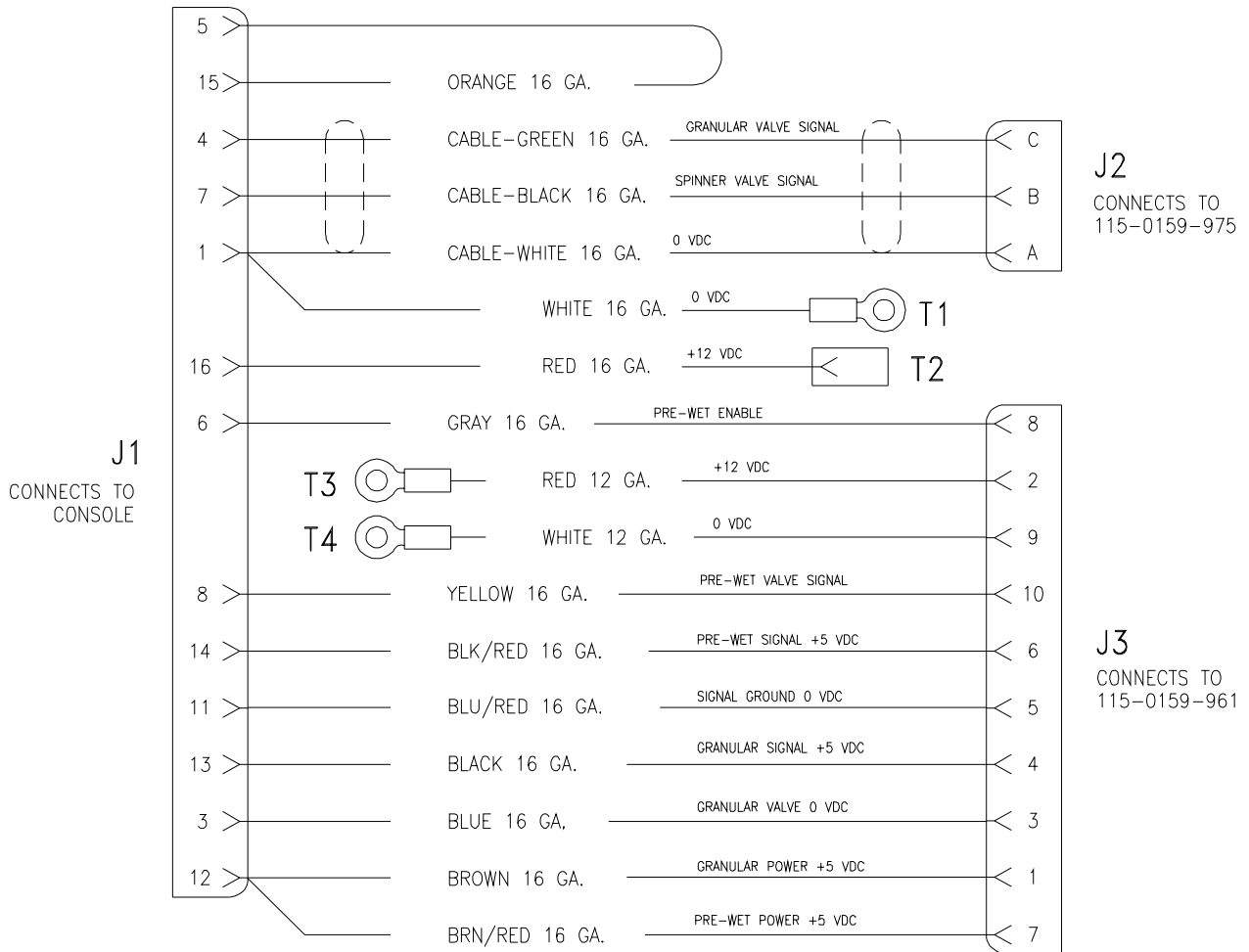

**CABLE,
VALVE, DCS 700, IOWA
115-0159-975
(REV. NONE)**

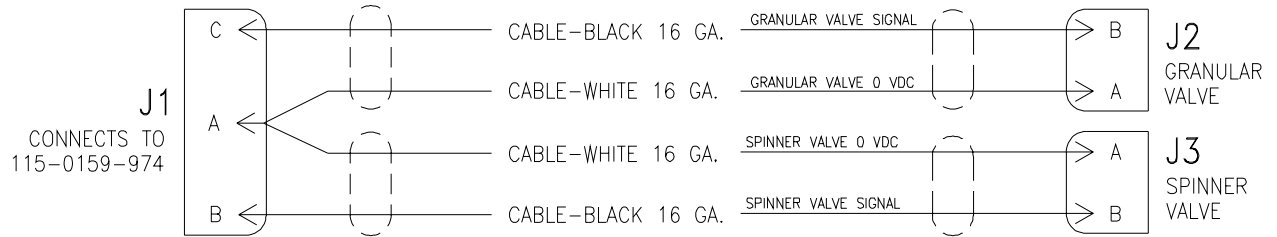

**CABLE,
7" PANEL MOUNT EXT.
115-0159-979
(REV. A)**

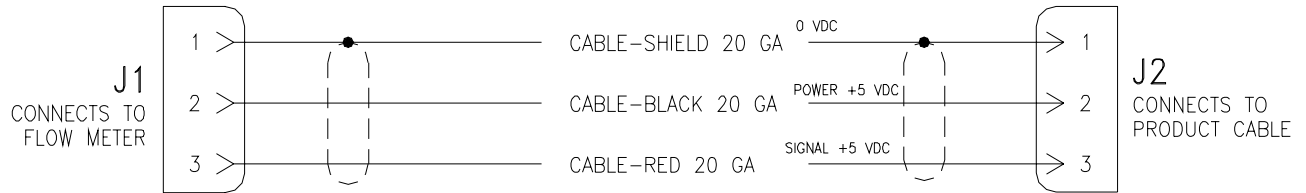

CABLE, 2' PRE-WET 115-0171-011 (REV. NONE)

CONNECTS TO
115-0159-956 J1

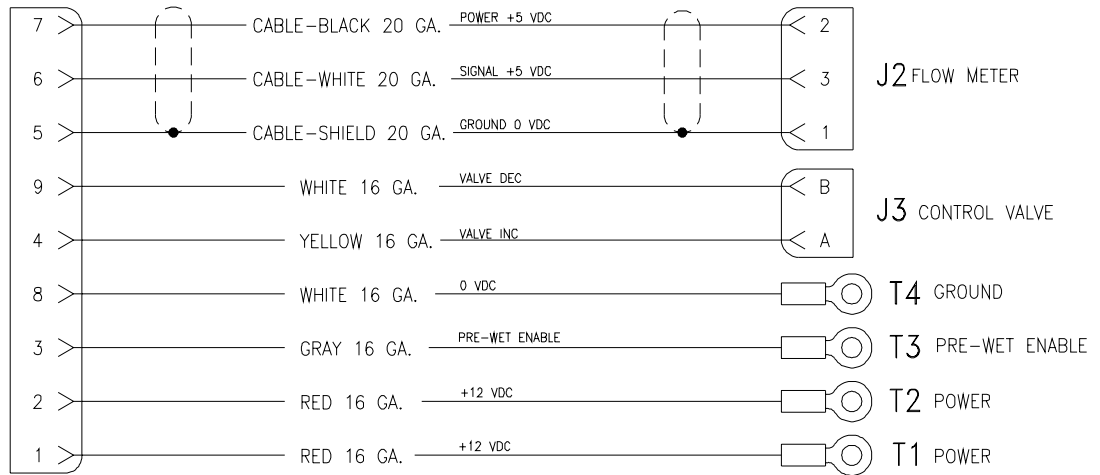

**CABLE,
GRANULAR SENSOR ADAPTER
115-0171-015
(REV. NONE)**



CABLE, GRANULAR SENSOR ADAPTER 115-0171-016 (REV. NONE)



**CABLE,
ADAPTER PLUG,
DLA 336 / DCS 700
115-0171-017
(REV. A)**

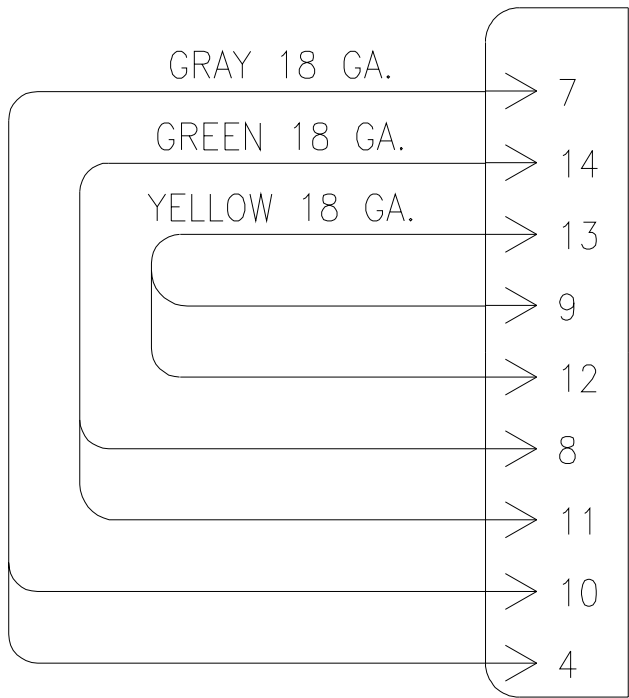

J1
CONNECTS
TO
115-0159-957

**CABLE,
GRANULAR SENSOR ADAPTER
115-0171-020
(REV. NONE)**



CABLE, GRANULAR & ANTI-ICE, "Y" 115-0171-024 (REV. A)

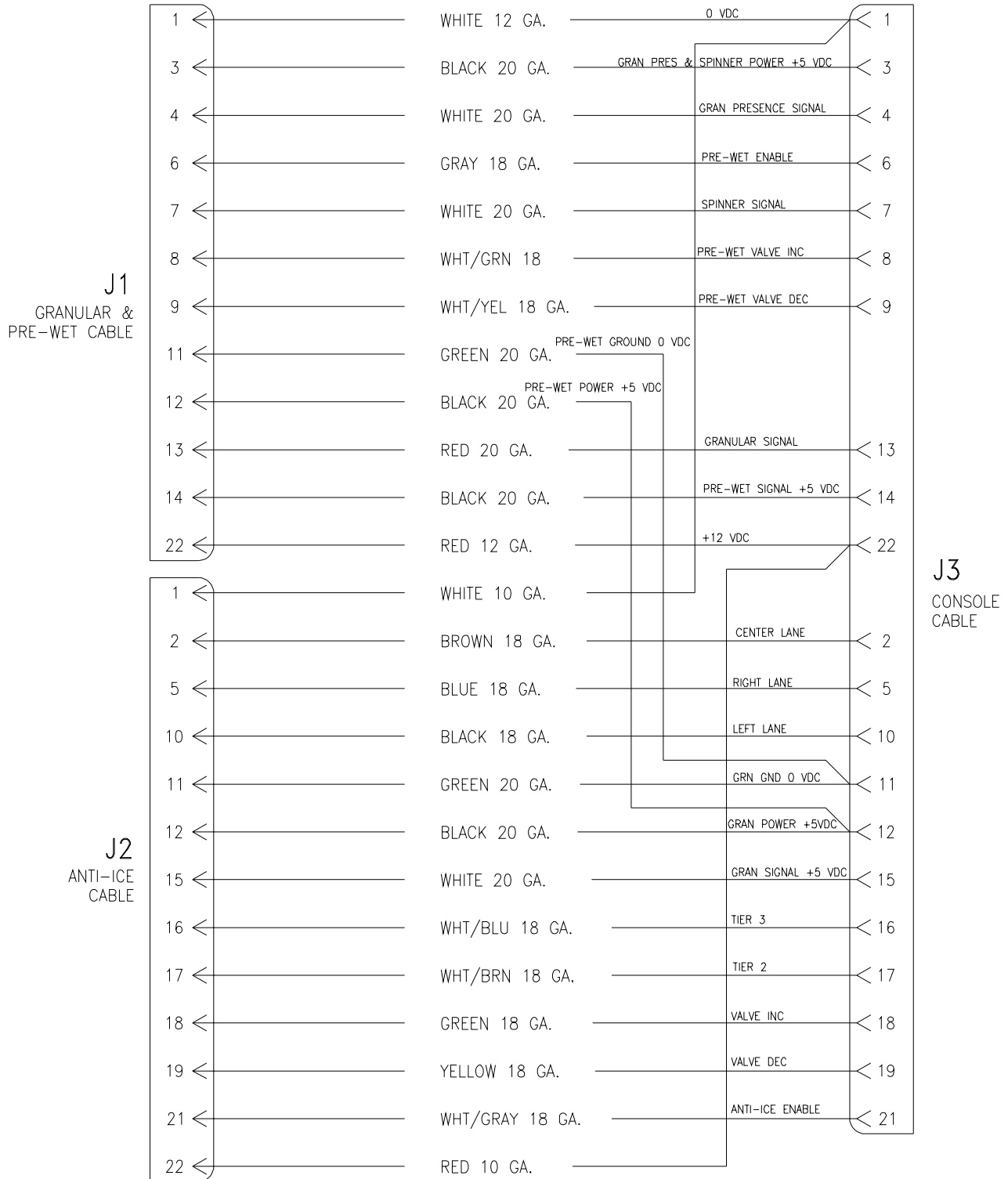

**CABLE,
T-CAB
115-0171-026
(REV. NONE)**

J1

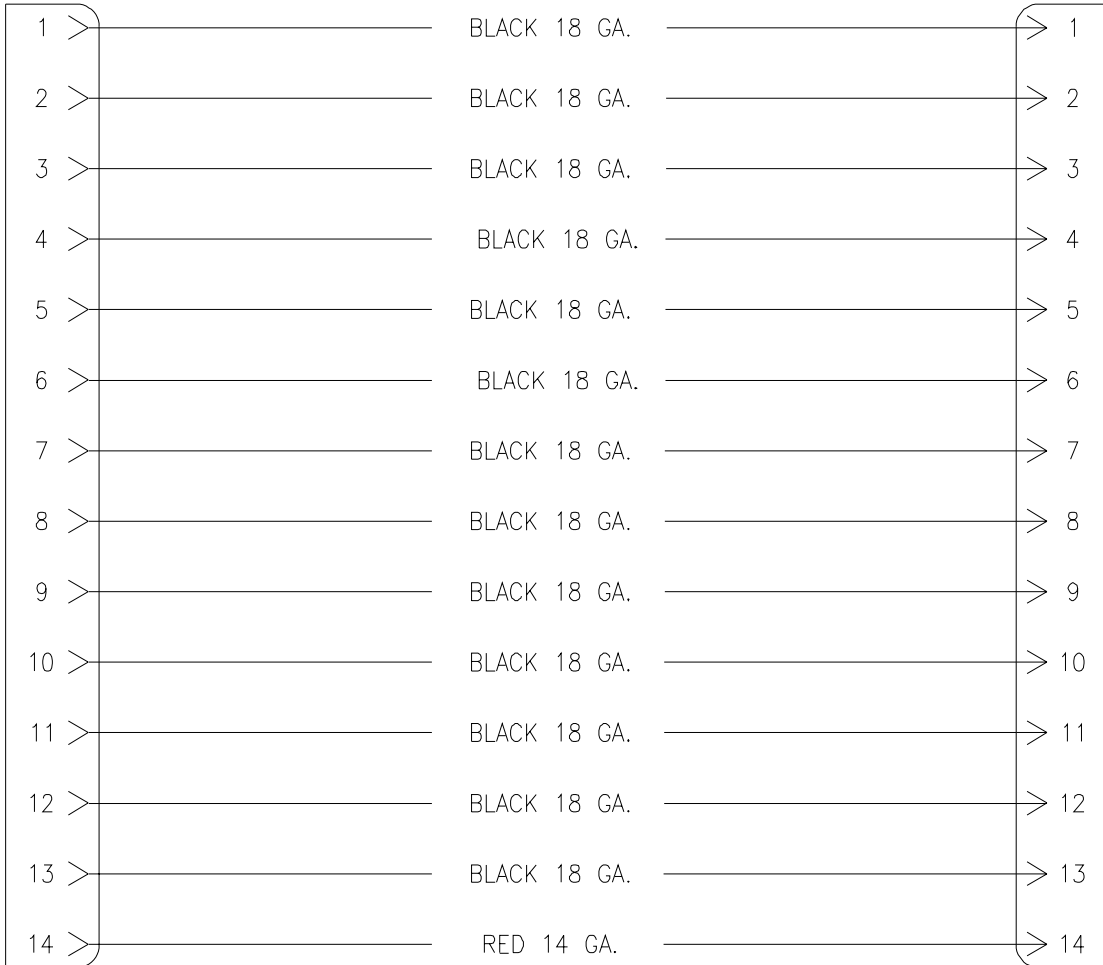

J2

**CABLE,
T-CAB
115-0171-027
(REV. NONE)**

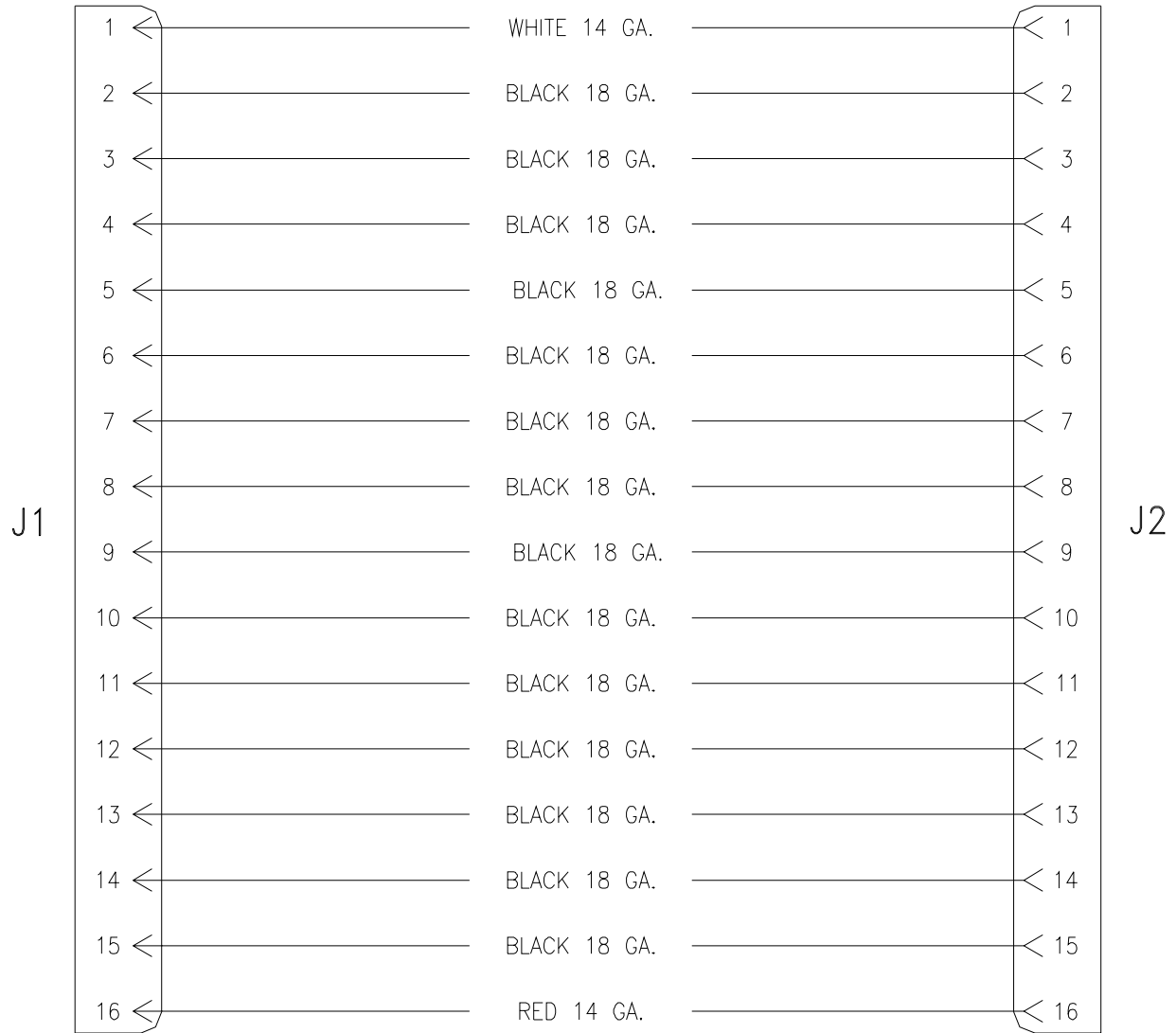

CABLE, LANE BOX 115-0171-033 (REV. A)

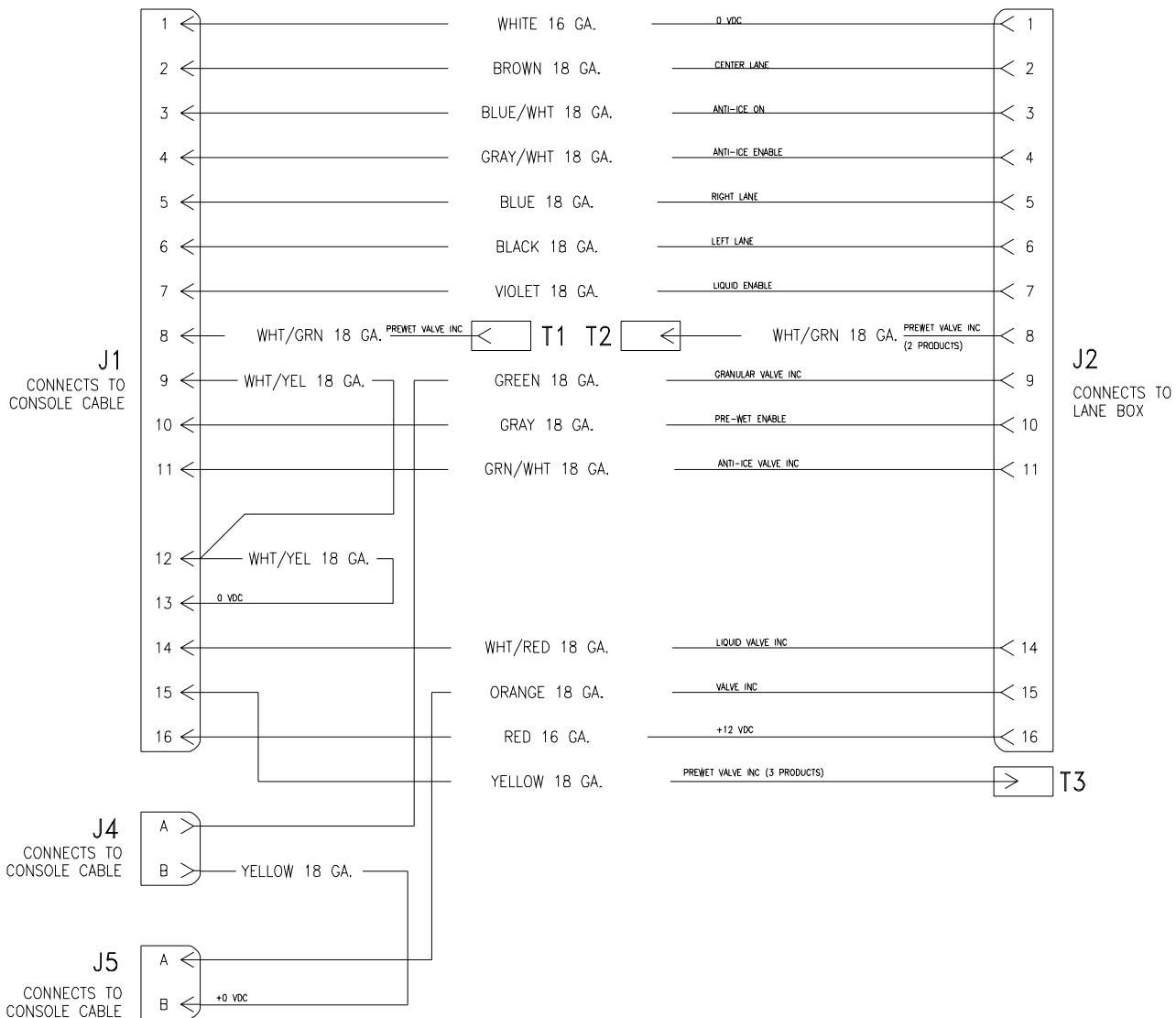

CABLE, 31' PRE-WET CONSOLE 115-0171-057 (REV. NONE)

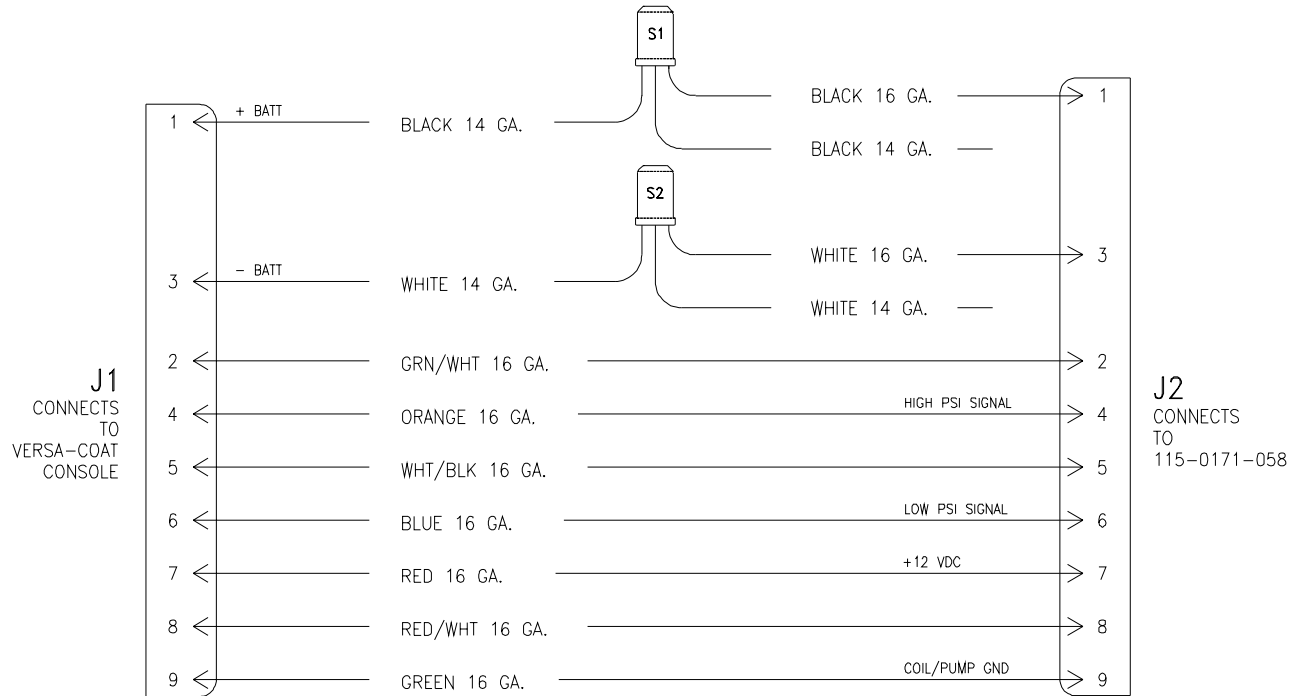

CABLE, 18' EXTENSION, PRE-WET 115-0171-058 (REV. B)

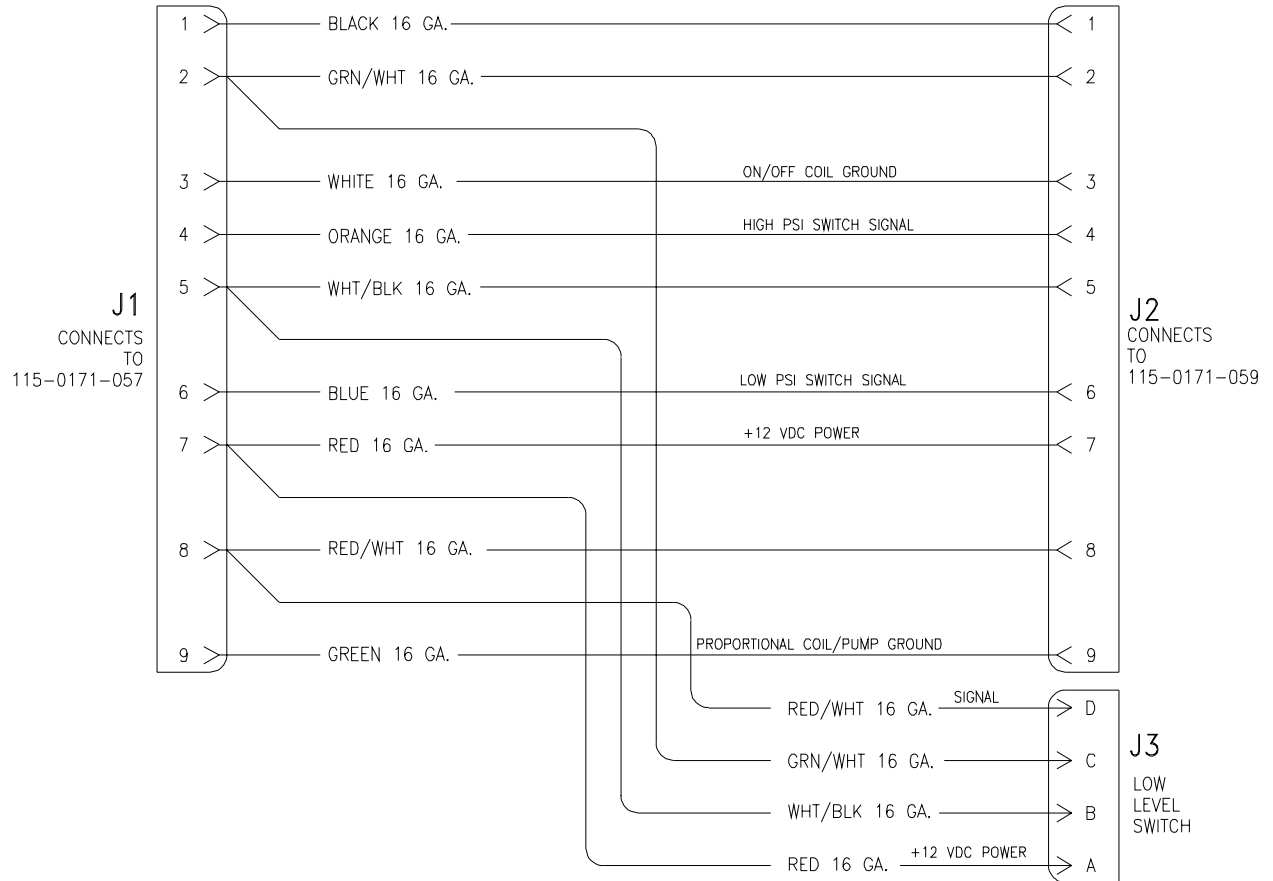

**CABLE,
21' PRODUCT, PRE-WET
115-0171-059
(REV. NONE)**

J1
CONNECTS TO
115-0171-057 OR
115-0171-058

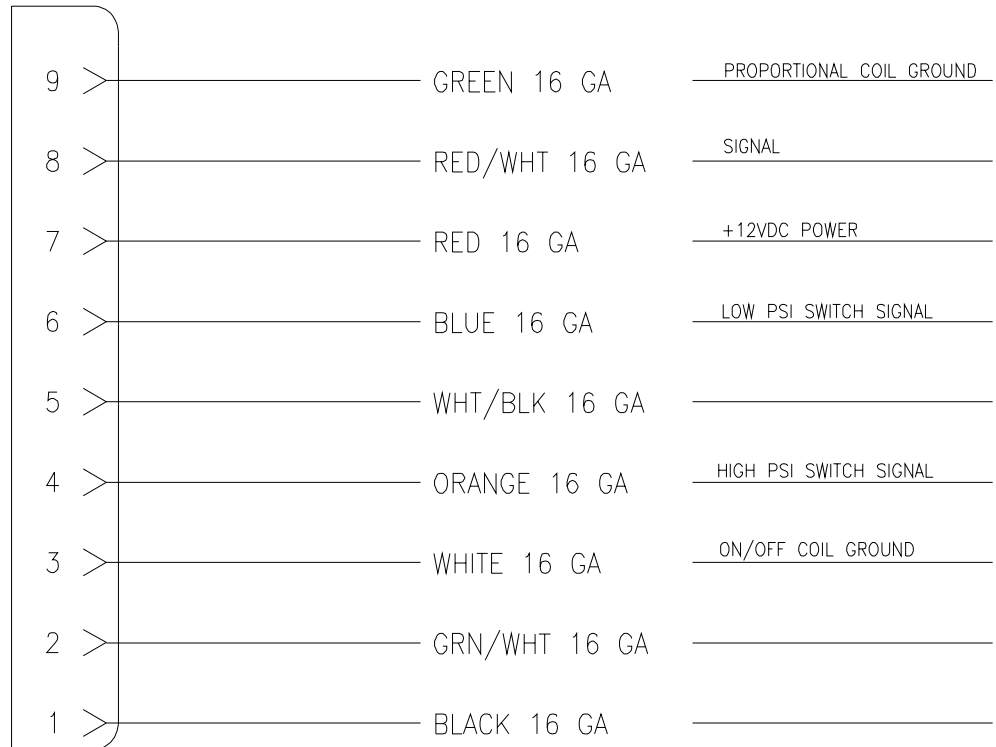

**CABLE,
VALVE ADAPTER
115-0171-060
(REV. NONE)**

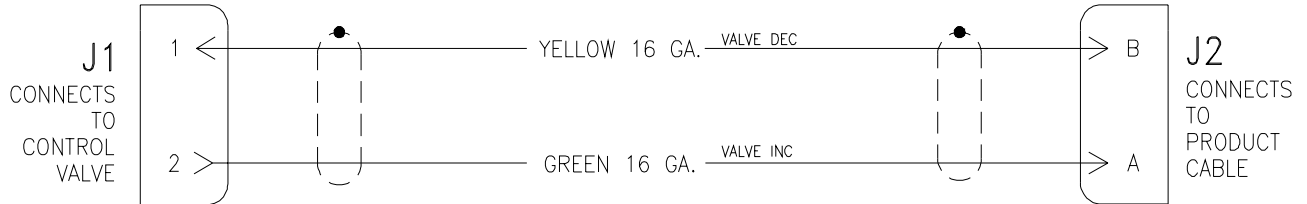

CABLE, GPS/TEMPERATURE SENSOR 115-0171-062 (REV. NONE)

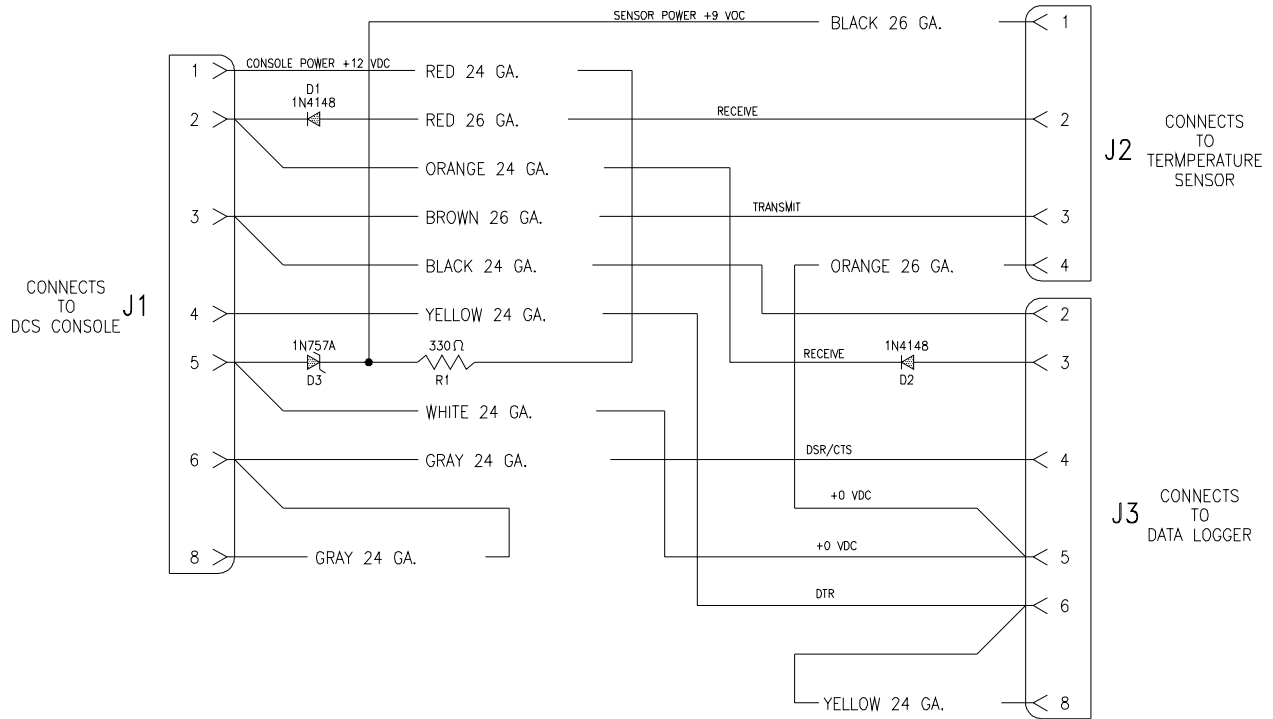

CABLE, CONSOLE, CLOSED LOOP SPINNER 115-0171-102 (REV. B)

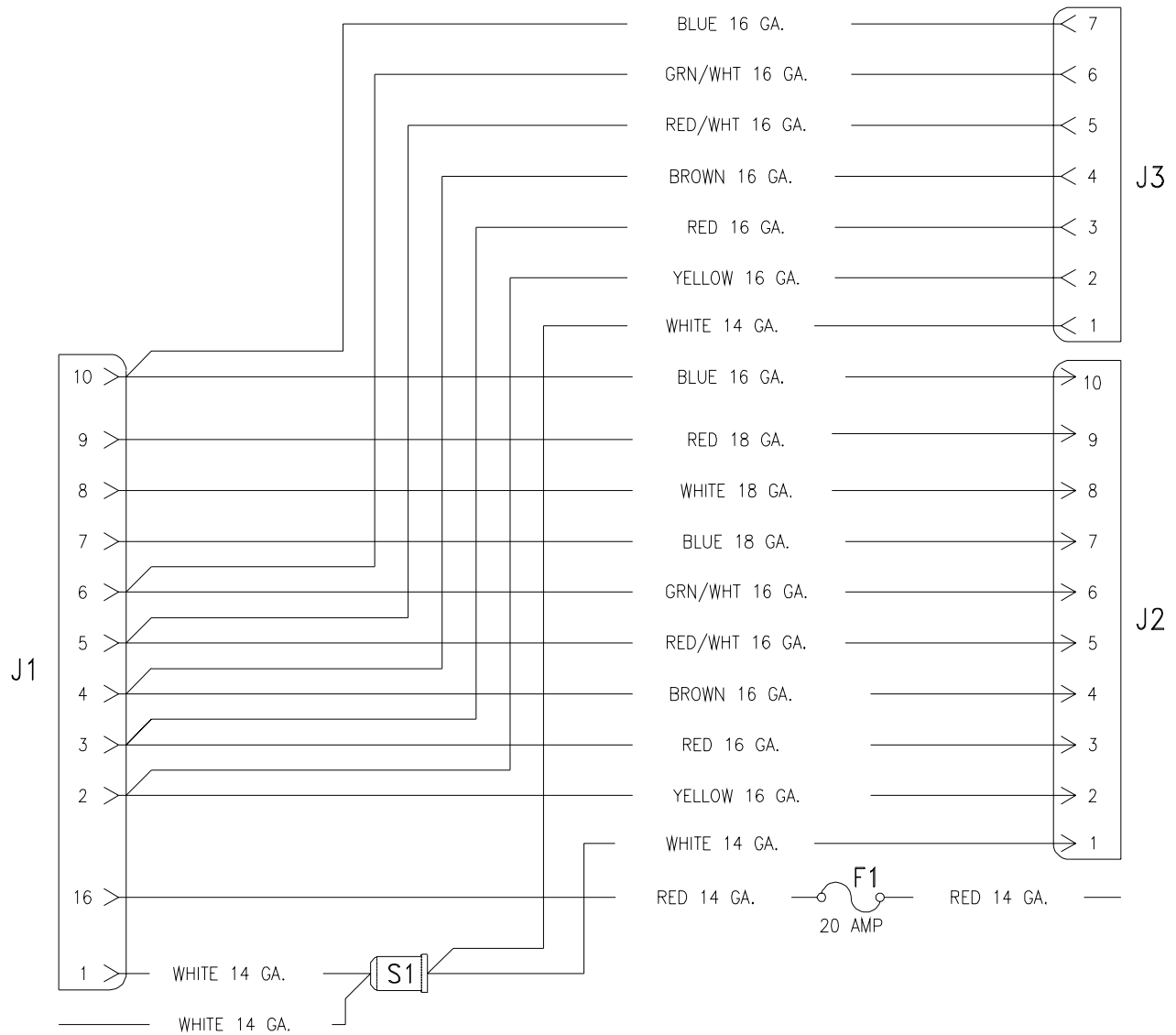

CABLE, PRODUCT, W/SPINNER OPTION 115-0171-112 (REV. NONE)

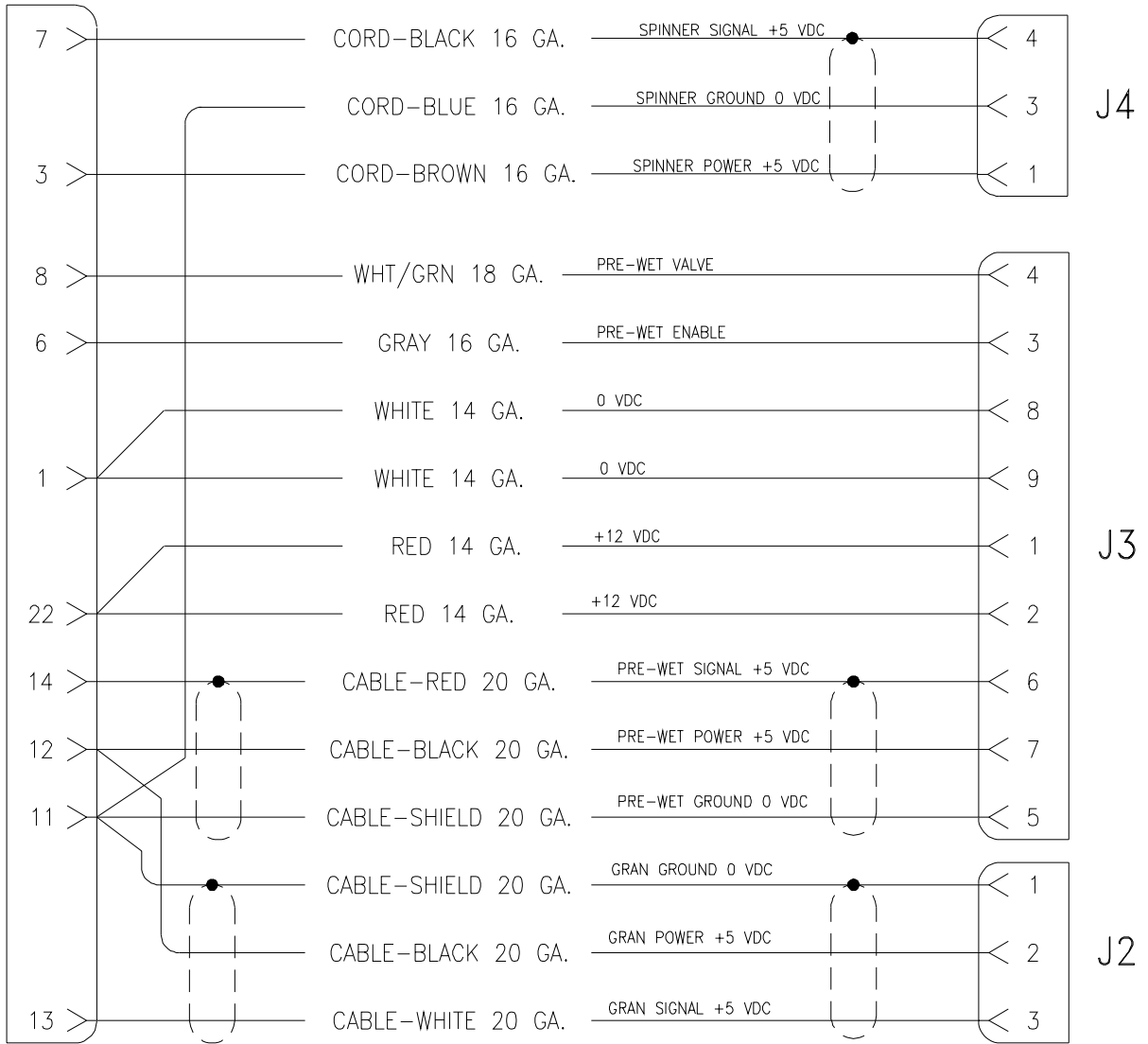

CABLE, CONSOLE, W/SPINNER OPTION

115-0171-113

(REV. B)

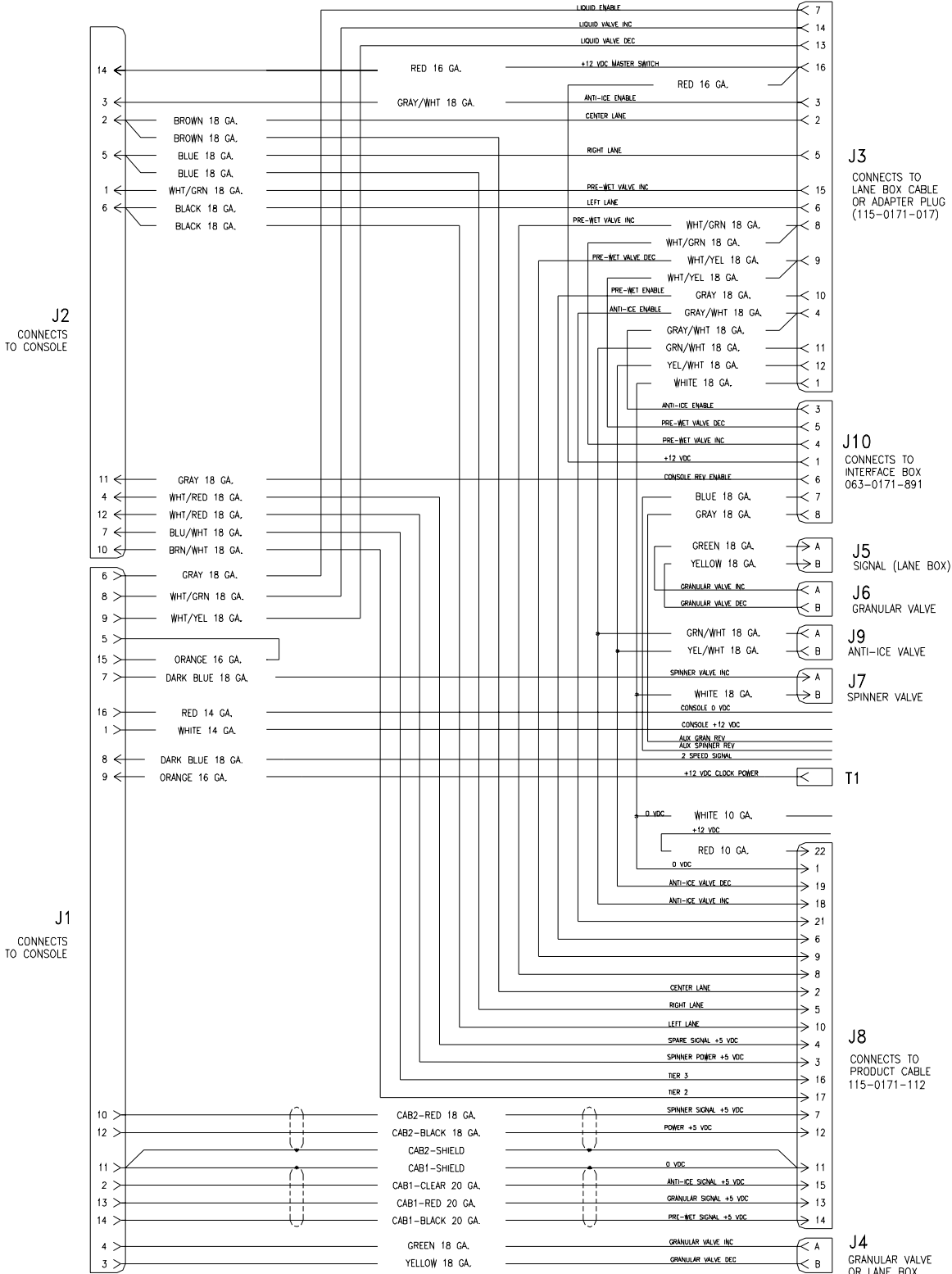

**CABLE,
6' CONSOLE, POWER
DCS 700 / 710
115-0171-127
(REV. A)**

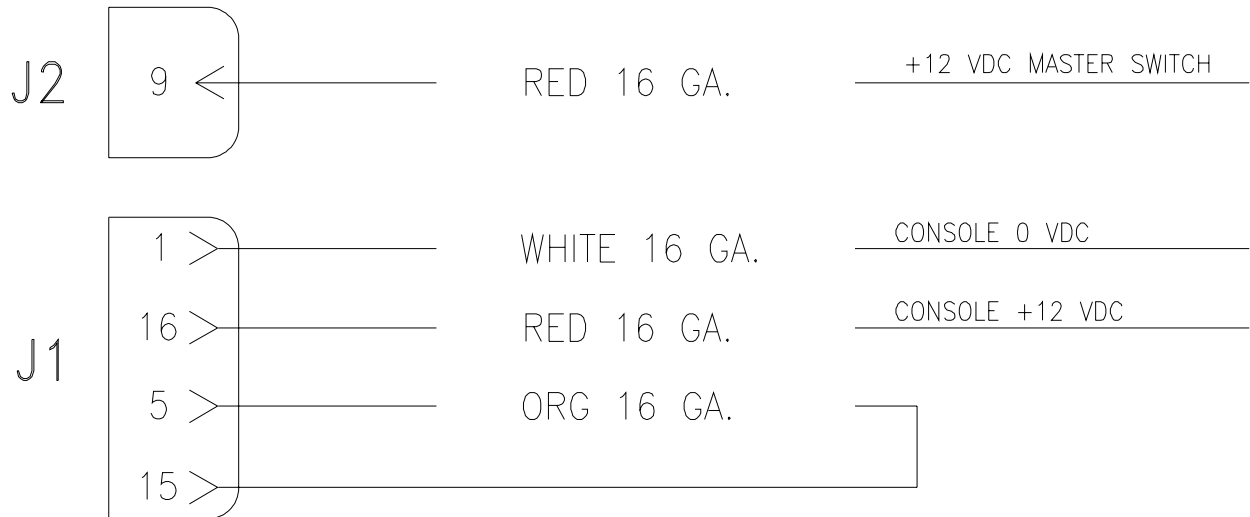

CABLE, 1', DCS 710 LIQUID FLOW JUMPER 115-0171-150 (REV. NONE)

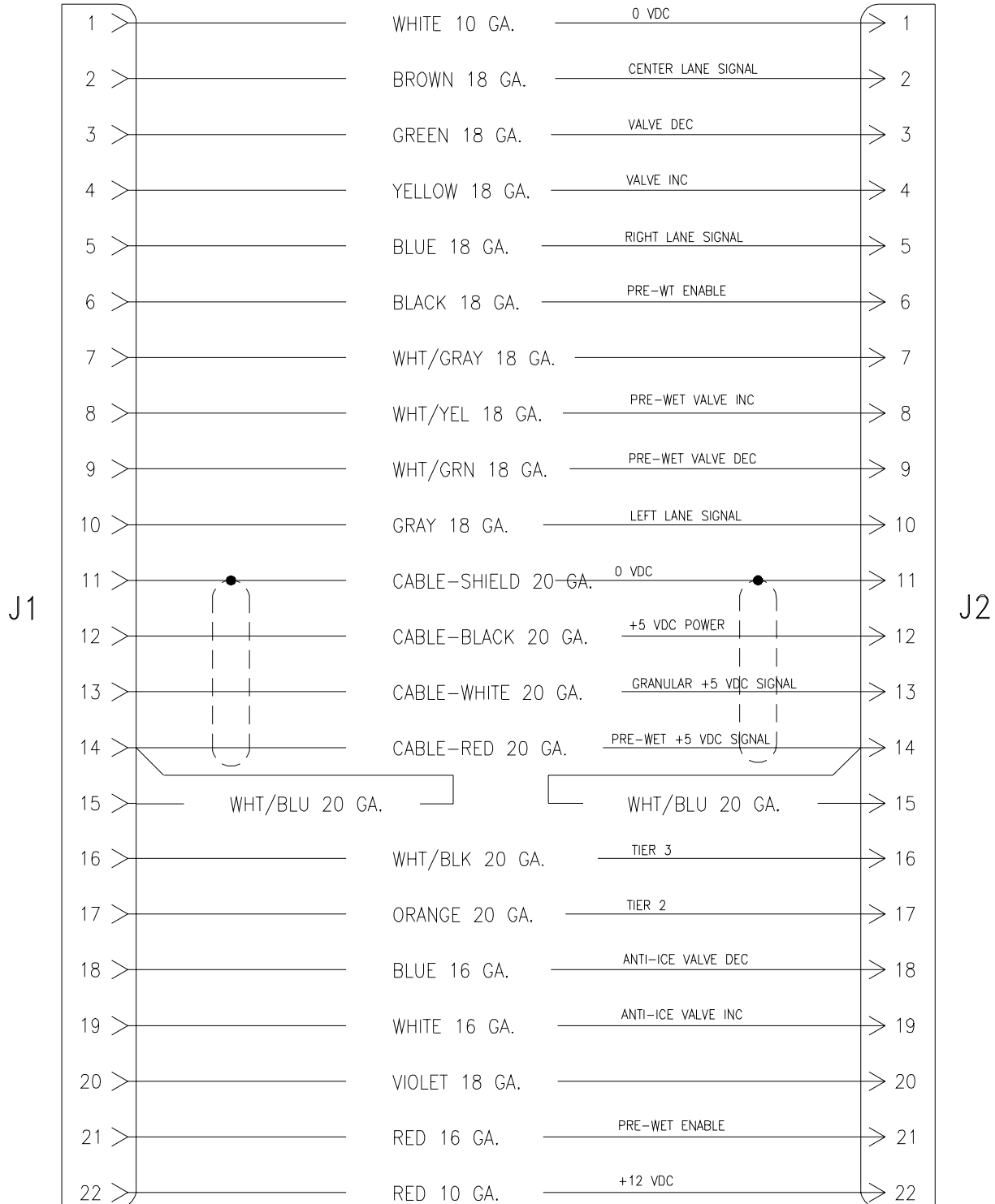

CABLE, 11' PRODUCT, DCS 710 MACK TRUCK 115-0171-188 (REV. NONE)

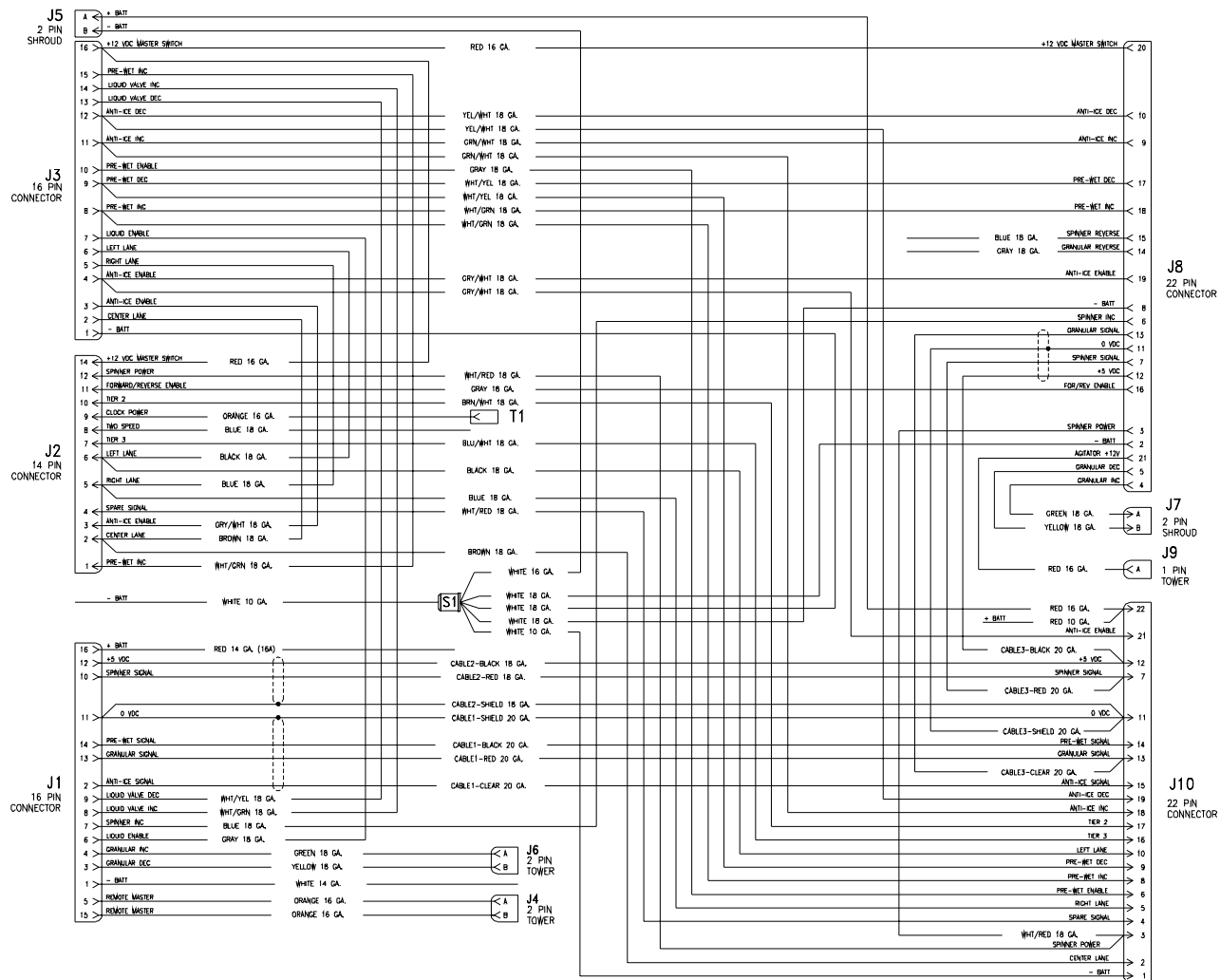

CABLE, 12' EXTENSION, DCS 710 115-0171-189 (REV. NONE)

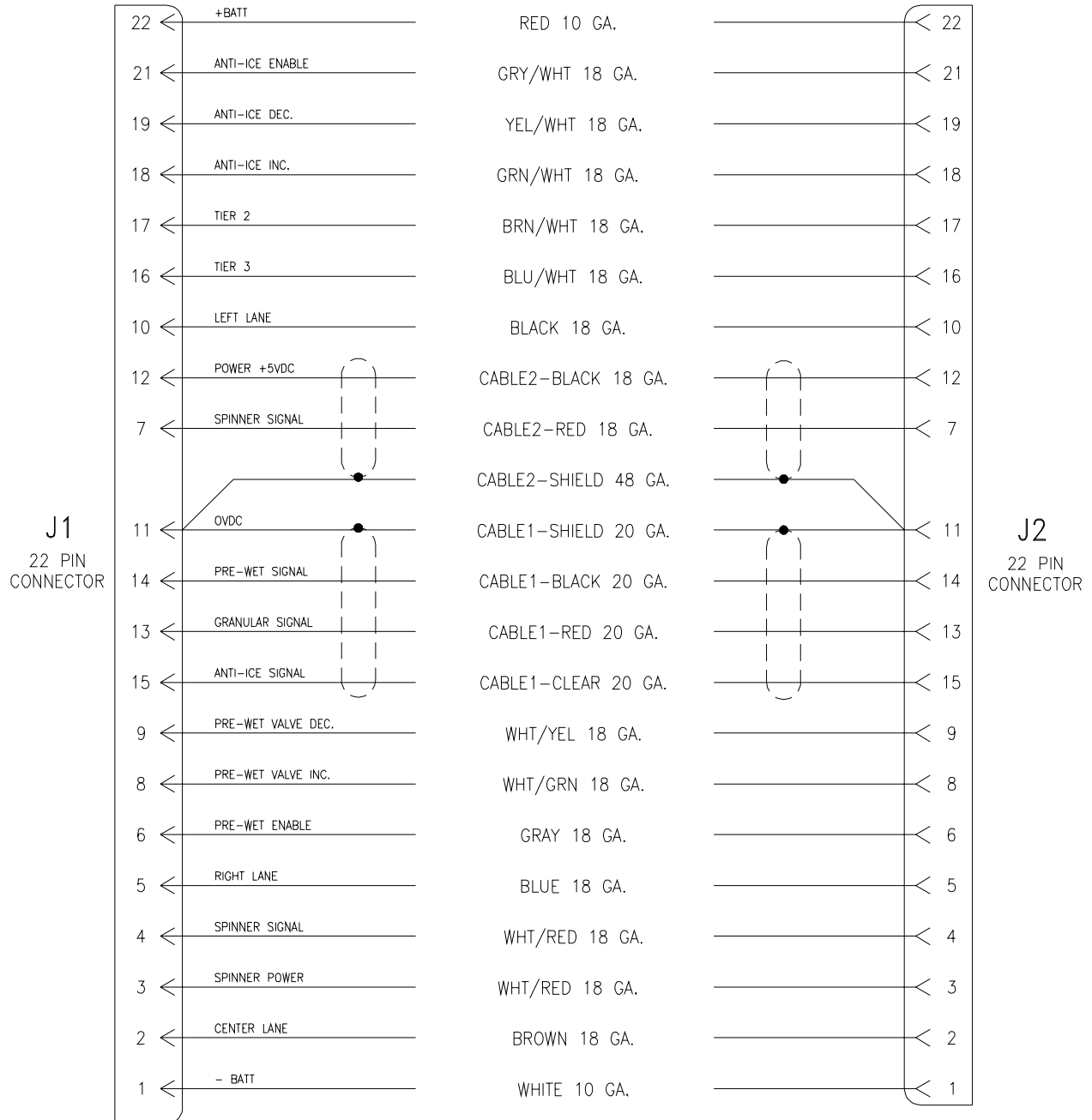

CABLE, 17' EXTENSION, DCS 710 115-0171-190 (REV. NONE)

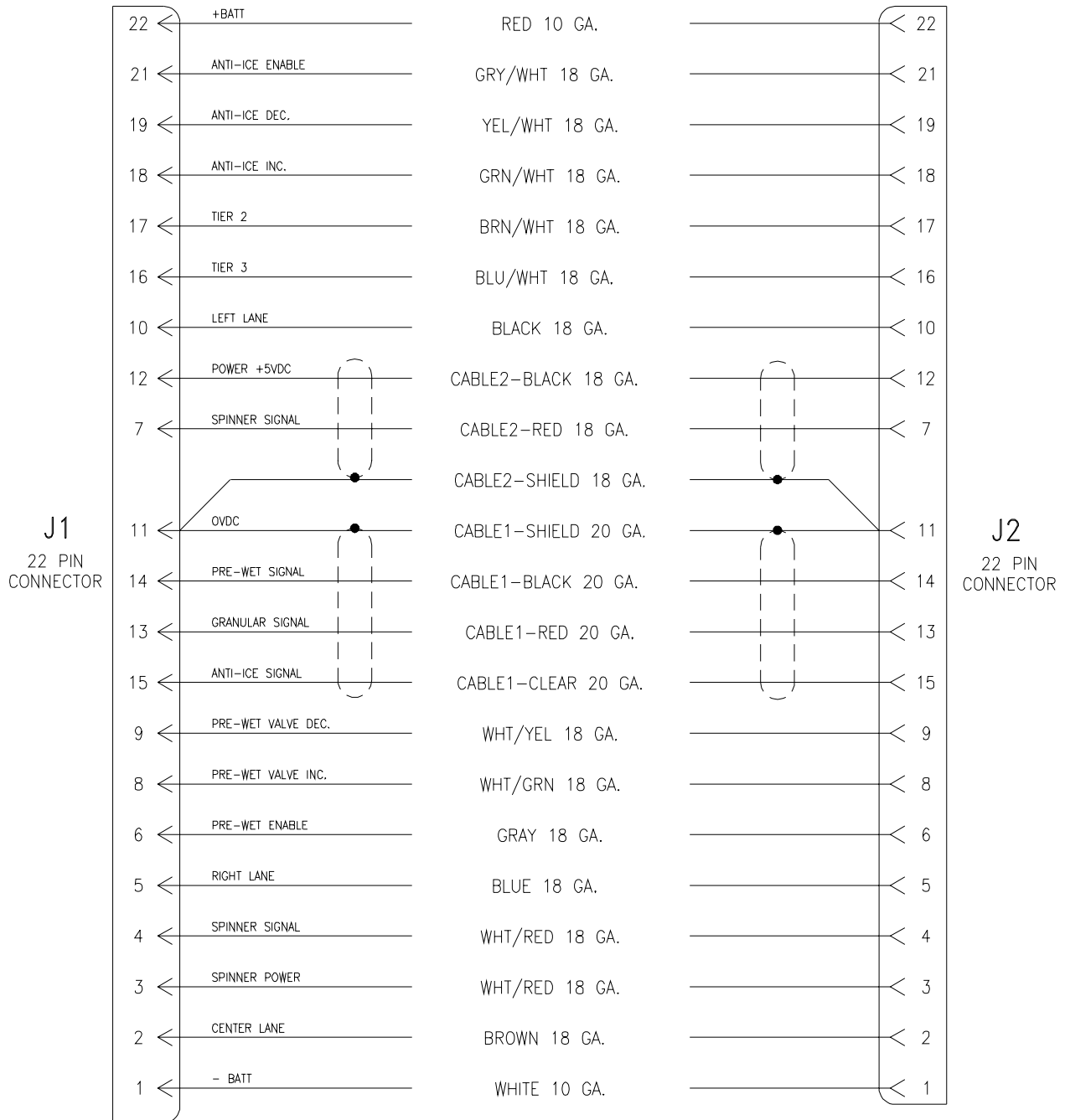

CABLE, 3' SOLENOID, DCS 710 115-0171-191 (REV. NONE)

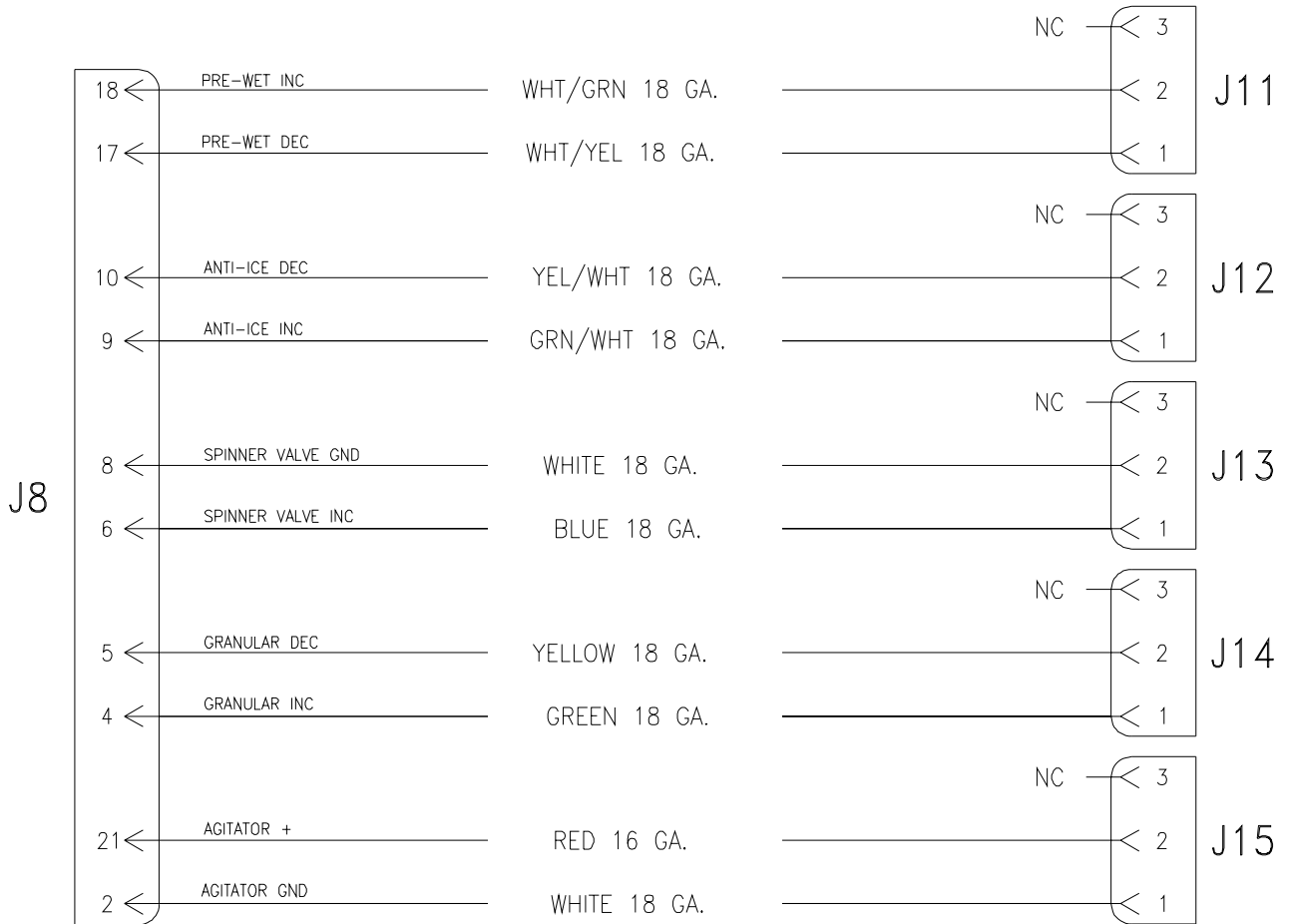

CABLE, 10', CONSOLE, DCS 710, IHC 115-0171-200 (REV. NONE)

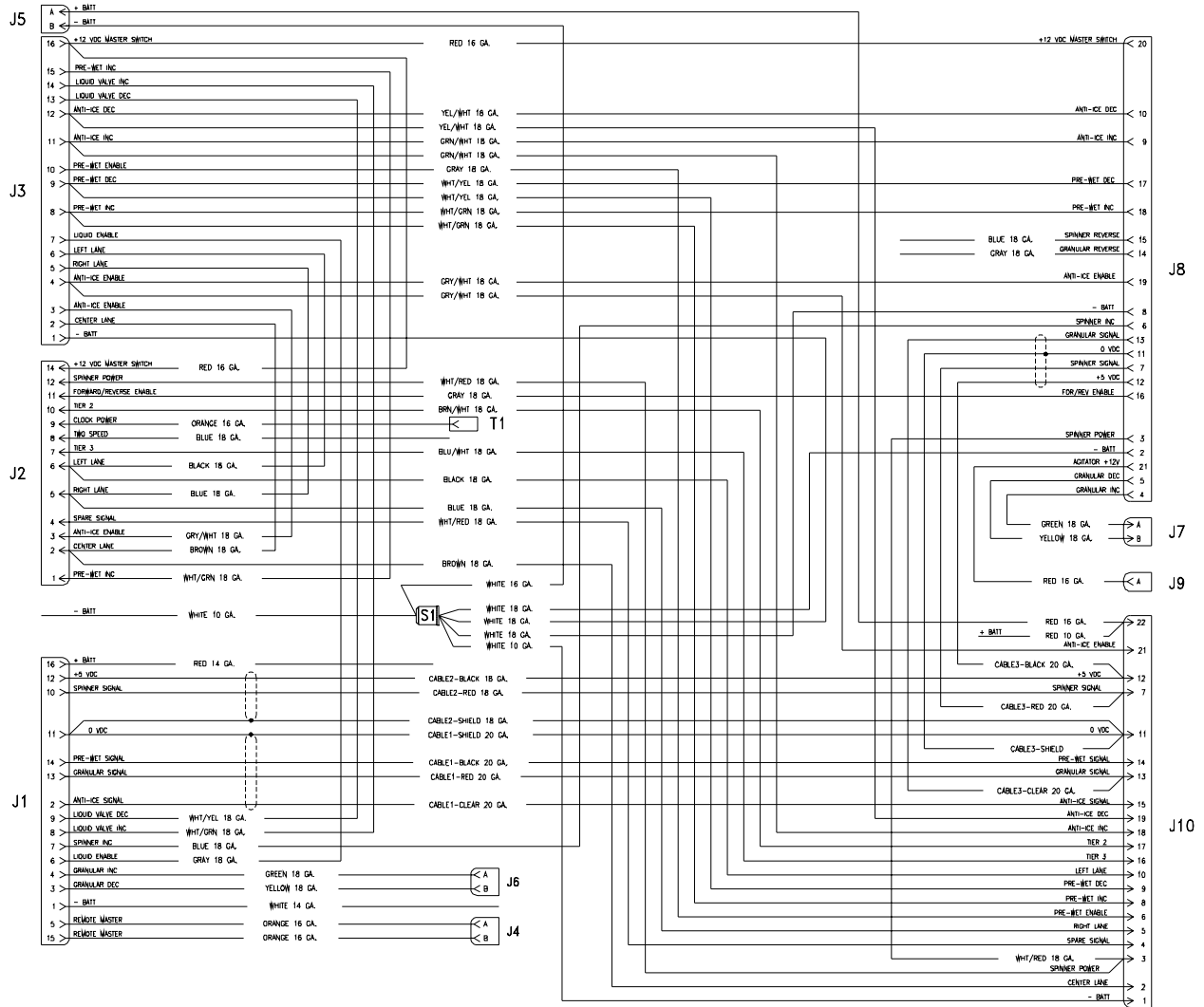

CABLE, 3' SOLENOID, CLOSED LOOP 115-0171-210 (REV. A)

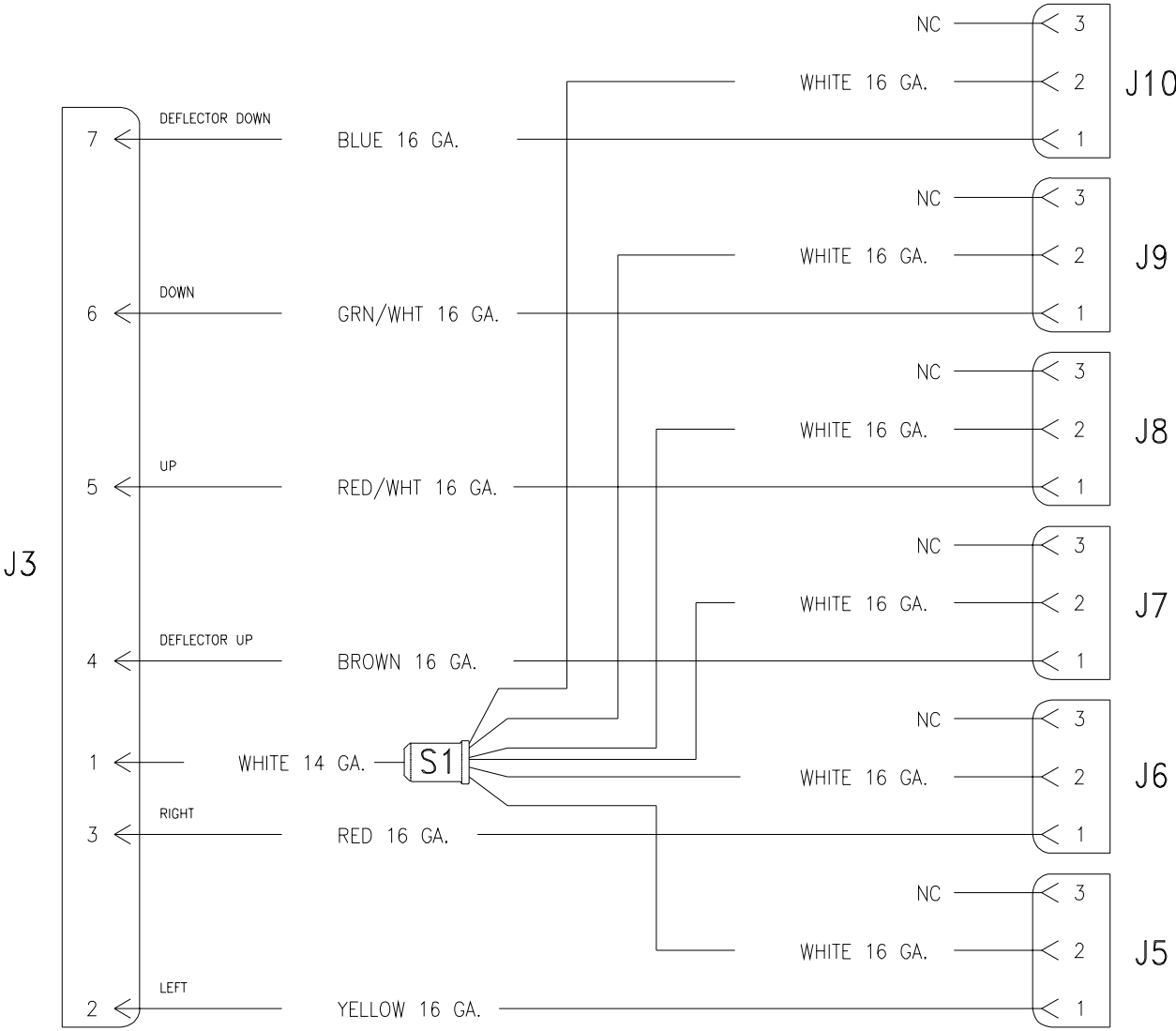

CABLE, 24' PRODUCT, DCS 400 115-0171-229 (REV. NONE)

