

DLA 336
Installation & Service Manual

P/N 016-0159-750 Rev A 09/15

N O T I C E

The use of the suspension type chemicals and slurries will significantly reduce the life of the plastic parts in the Flow Meter and motorized Control Valve. Check the rotor and inlet hub assembly in the Flow Meter frequently for worn parts. Excessive wear can affect accuracy.

Do not attempt to modify or lengthen any of the three-wire Speed Sensor or Flow Meter cables. Extension cables are available from your Dealer.

THIS CARD IS PROVIDED FOR YOUR CONVENIENCE. PENCIL IN YOUR CALIBRATION NUMBERS FOR FUTURE REFERENCE.
 CUT ON DOTTED LINE, FOLD, AND INSERT INTO PLASTIC ENVELOPE.

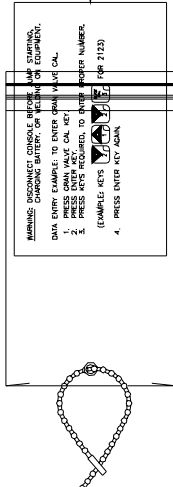

WARNING: DISCONNECT CONSOLE BEFORE JUMP STARTING.
 CHARGING BATTERY OR WELDING ON EQUIPMENT.
 DATA ENTRY EXAMPLE: TO ENTER METER CAL.
 1. PRESS METER CAL KEY.
 2. PRESS ENTER KEY.
 3. PRESS KEYS REQUIRED, TO ENTER PROPER NUMBER.
 (EXAMPLE: KEYS FOR 2123)
 4. PRESS ENTER KEY AGAIN.

NEUTRAL ON DOTTED LINE





FOLD NO SOLID LINES

INSERT AND ZIP SHUT

(DLA 336)

**WARNING: DISCONNECT CONSOLE BEFORE JUMP STARTING,
 CHARGING BATTERY, OR WELDING ON EQUIPMENT.**

DATA ENTRY EXAMPLE: TO ENTER METER CAL.

1. PRESS METER CAL KEY.
 2. PRESS ENTER KEY.
 3. PRESS KEYS REQUIRED, TO ENTER PROPER NUMBER.
 4. PRESS ENTER KEY AGAIN.
- (EXAMPLE: KEYS     FOR 2123)

OFFSET:

 ANTI-ICE HIGH _____

ANTI-ICE LOW _____

VALVE FREQUENCY _____

ADDITIONAL NOTES:
 TRUCK NUMBER: _____

 BLAST RATE _____
 BLAST TIME _____

 SPEED CAL _____

 METER CAL _____

 VALVE CAL _____

 RATE CAL

RATE 1 _____

RATE 2 _____

RATE 3 _____

RATE 4 _____

RATE 5 _____

RATE 6 _____

RATE 7 _____

RATE 8 _____

RATE 9 _____

RATE 10 _____

TABLE OF CONTENTS

SYMBOL DEFINITION	3
INTRODUCTION	4
INSTALLATION.....	5
1. INSTALLATION OF RAVEN RADAR	5
2. MOUNTING THE FLOW METER	6
3. MOUNTING THE CONTROL VALVE	6
4. MOUNTING THE CONSOLE AND CABLING.....	7
FUSE BLOCK CONNECTIONS.....	7
CONSOLE FEATURES.....	8
CONSOLE PROGRAMMING.....	9
1. INITIAL CONSOLE PROGRAMMING	10
CONSOLE CALIBRATION.....	12
1. CALCULATING OFFSETS	12
2. CALCULATING "SPEED CAL"	13
OTHER CONSOLE FEATURES.....	14
1. VOL/TANK	14
2. LOW TANK ALARM	14
3. LOW TANK LEVEL SHUT-OFF	14
4. ZERO SPEED SHUT-OFF	14
5. TIME.....	15
6. TEMP.....	15
7. SELF TEST FEATURE	16
8. DISTANCE AND VOLUME DISPLAYS.....	17
9. VOL/MIN AND LOW LIMIT FLOW ALARM.....	17
10. AREA/HOUR	18
11. BLAST BUTTON	18
12. CONTROL VALVE DELAY	18
13. AUTOMATIC RATE +/-	19
14. MANUAL MODE LOCK OUT	19
DATA MENU	20
SERIAL PORT SCREENS	20
GLOBAL POSITIONING SYSTEM SCREENS.....	22
ALARM SCREENS	22
MISCELLANEOUS SCREENS	24
OFFSET SCREENS	25
CAL SCREENS.....	25
LANE SCREENS	26
BLAST SCREENS	27

APPENDIXES

1. SPEED SENSOR CALIBRATION PROCEDURE	28
2. CALCULATING "LIQ VALVE CAL"	29
3. ENTERING OFFSET VALUES	30
4. PROCEDURE TO TEST SPEED SENSOR EXTENSION CABLES	31
5. PROCEDURE TO TEST FLOW METER CABLES	32
6. FLOW METER MAINTENANCE AND ADJUSTMENT PROCEDURE	33
7. PROCEDURE TO RE-CALIBRATE FLOW METER	34
8. REMOTE SWITCH OPTION	35
9. INSTALLATION OF RAVEN RADAR	36
10. DLA 336 DATA MENU REFERENCE GUIDE	37
REPLACEMENT PARTS SHEETS	

SYMBOL DEFINITION

GPM	- Gallons per minute	gal	- Gallons
lit/min	- Liters per minute	lit	- Liters
dl/min	- Deciliter per minute	MPH	- Miles per hour
PSI	- Pounds per square inch	km	- Kilometers
kPa	- Kilopascal	km/h	- Kilometers per hour
GPK	- Gallons per 1,000 sq. ft.	US	- Volume per lane mile
mm	- Millimeters	SI	- Volume per lane kilometer
cm	- Centimeters	TU	- Volume per 1,000 sq. ft.
dm	- Decimeters	[]	- Metric numbers
m	- Meter	{ }	- 1,000 sq. ft. numbers

METER CAL CONVERSIONS

To convert the METER CAL number simply divide the original number (number printed on Flow Meter label) by the desired conversion factor.

FOR EXAMPLE:

$$\frac{\text{Original METER CAL No.}}{128} = \text{METER CAL No. for displays in Fluid Ounces}$$

$$\frac{\text{Original METER CAL No.}}{3.785} = \text{METER CAL No. for displays in Liters}$$

$$\frac{\text{Original METER CAL No.}}{\text{Weight of one gallon}} = \text{METER CAL No. for displays in Pounds}$$

LIQUID CONVERSIONS

U.S. Gallons x 128 = Fluid Ounces
U.S. Gallons x 3.785 = Liters
U.S. Gallons x 0.83267 = Imperial Gallons
U.S. Gallons x 8.34 = Pounds (Water)

LENGTH

1 millimeter (mm) = 0.039 inch
1 centimeter (cm) = 0.393 inch
1 meter (m) = 3.281 feet
1 kilometer (km) = 0.621 mile
1 inch = 25.4 millimeters; 2.54 centimeters
1 mile = 1.609 kilometers
1 mile = 5280 feet

PRESSURE

1 psi = 6.89 kPa
1 kPa = 0.145 psi

AREA

1 square meter = 10.764 square feet
1 hectare (ha) = 2.471 acres; 10,000 square meters
1 acre = 0.405 hectare; 43,560 square feet
1 square mile = 640 acres; 258.9 hectares

INTRODUCTION

The Raven DLA 336 (Direct Liquid Application System) is designed to improve the uniformity and accuracy of liquid anti-ice applications.

The DLA 336 consists of a microprocessor-based control console, speed sensor, liquid flow meter, shut-off valves, and a control valve. The Console mounts directly in the cab of the vehicle for easy operator use. The speed sensor is installed in one of several locations based on the style of speed sensor used. The valves and flow meter mount in the best location available for ease of installation and service. Appropriate cabling is furnished for dealer/field installation.

The operator selects the desired application rate and the DLA 336 automatically maintains the rate regardless of vehicle speed to ensure accurate application. The operator can select one of the 10 pre-programmed application rates or a manual mode. Material can also be applied at a higher application rate instantly by depressing the Blast button. The DLA 336 also displays additional information such as air and road surface temperature (must be equipped with sensor), distance traveled and material volume totals, and vehicle speed.

INSTALLATION

1. INSTALLATION OF RAVEN RADAR

For mounting the Radar, the following guidelines will assure proper installation: It is suggested that a large heavy mounting bracket, (P/N 107-0159-693) be attached to the vehicle frame for mounting the Radar.

- 1) Park vehicle on level surface.
- 2) Select mounting site by considering the following:
 - a) The line of sight from the lens to the ground must not be obstructed by structures or tires. Obstructions must not come closer than 20 inches to the bottom of the Radar. See Figures 1 and 2.
 - b) The Radar lens must be parallel to the ground from front to back. Radar can be tilted out 0-15 degrees to provide more clearance and miss obstructions. See Figure 2. Figure 2.
 - c) The Radar should be mounted so that the **length** of the Radar is **parallel** with direction of vehicle travel.
- 3) Use carpenters level to verify that mounting bracket is parallel to the ground.
- 4) Bolt mounting bracket to implement.
- 5) Bolt Radar to mounting bracket using mounting hardware. See Figure 3.
- 6) Connect Radar with Radar Interface Cable (P/N 115-0159-539), to the DLA 336 Console. The Red wire should be connected to 12 VDC. The White wire should be connected to ground.

CAUTION: The connection of the Radar power in reverse polarity could result in damage to the Radar.

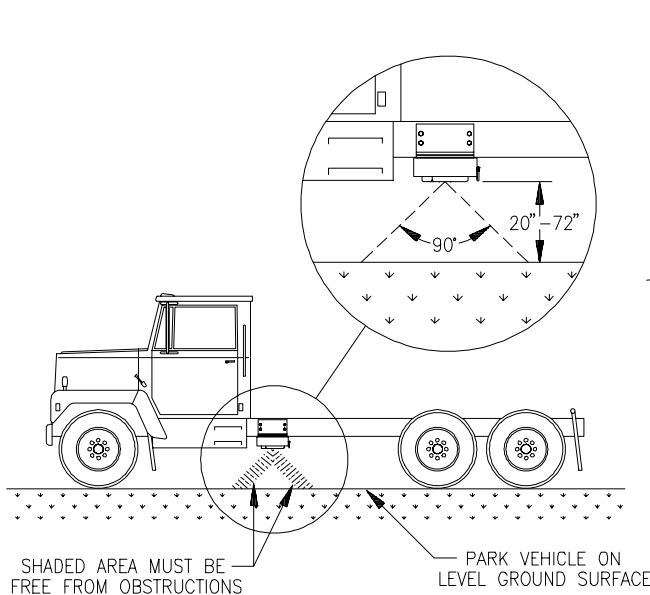

FIGURE 1

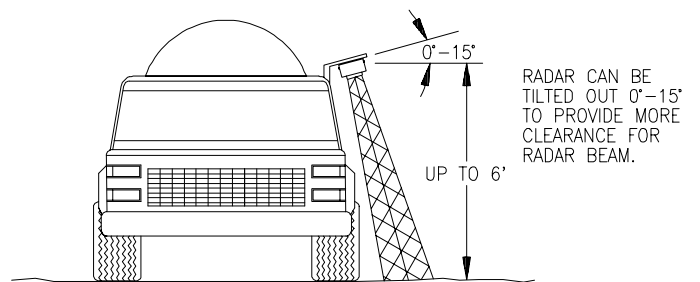

FIGURE 2

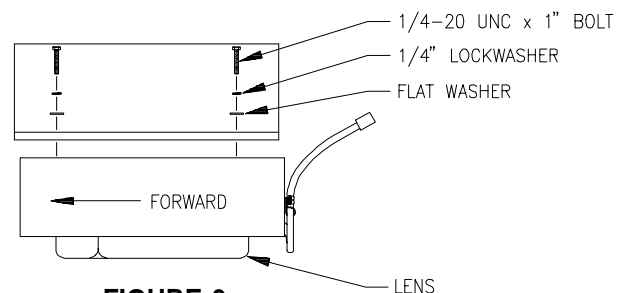
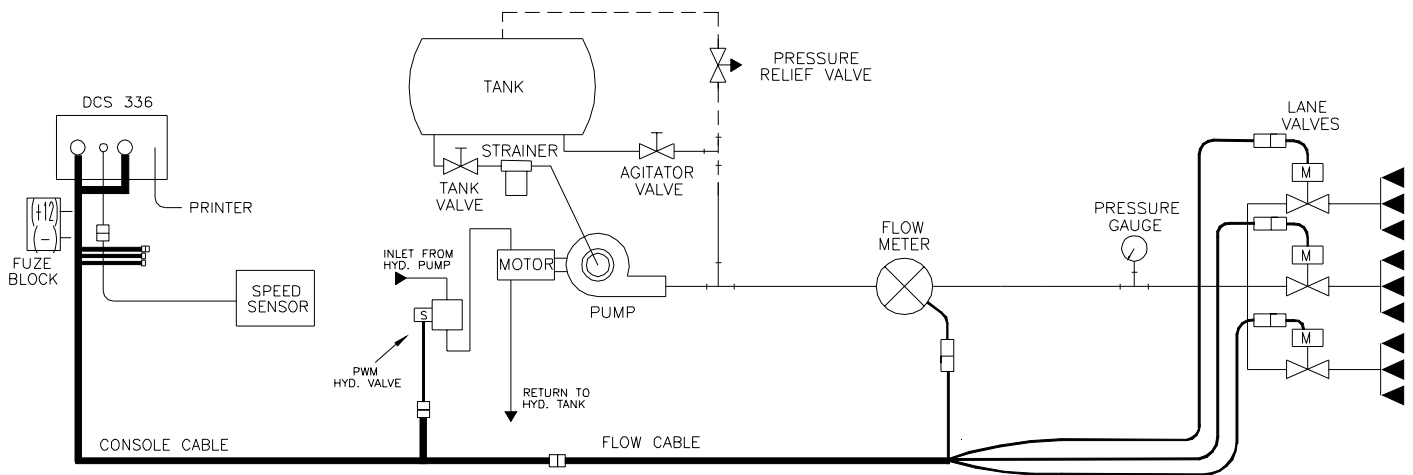

FIGURE 3

2. MOUNTING FLOW METER AND CONTROL VALVE

- 1) Mount Flow Meter in the area of the liquid control per Figure 5. All flow through Flow Meter must go to nozzles only, i.e., no return line to tank or pump after Flow Meter.
- 2) Flow must be in direction of arrow on Flow Meter.

ANTI-ICE SCHEMATIC



TIER 2 SCHEMATIC

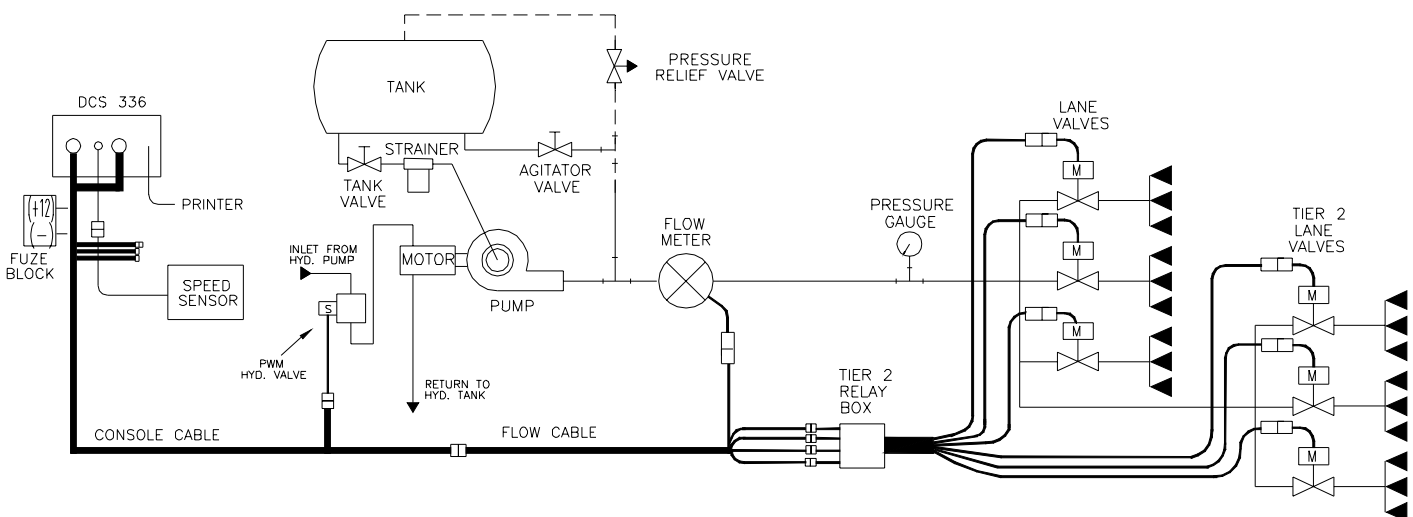

FIGURE 5

NOTE: This is two examples of application schematics.

It is essential, when using suspensions, that the system be thoroughly rinsed out each day after use.

3. MOUNTING CONSOLE AND CABLING

NOTE: For instructions on mounting custom cabling, hydraulic valves, and liquid control systems, consult your dealer.

- 1) Mount the Console to a secure support inside the cab of the vehicle without hindering the visibility of the operator.
- 2) Connect the Console Control Cable to the plugs in the back of the Console. (See Figure 7).

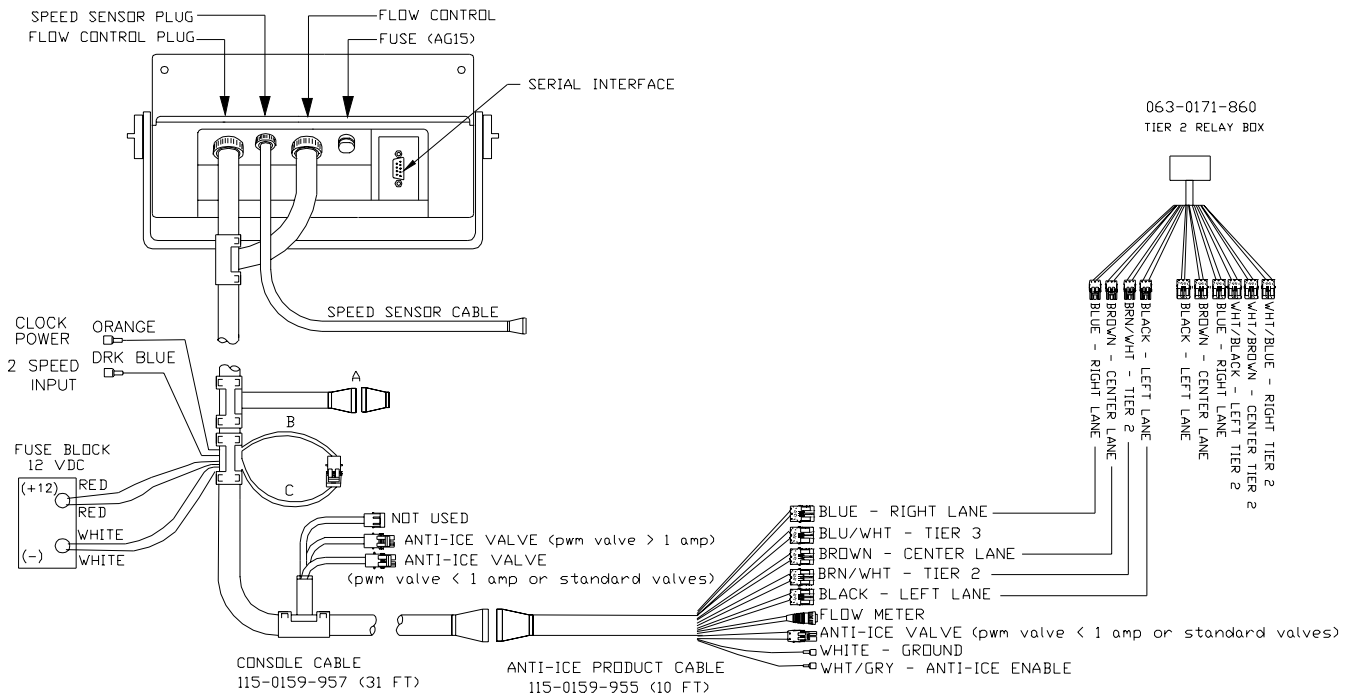

FIGURE 7

- 3) Turn POWER ON/OFF switch OFF and route the Red wire to the +12 volt fuse block and White wire to the negative connection. **(DO NOT CONNECT WIRES TO THE STARTER)**. Secure the wires with plastic cable ties.
- 4) Connect the Speed Sensor Cable to the plug in the back of the Console.
- 5) Verify connector "A" has plug installed and "B" is connected to "C".

CONSOLE FEATURES

IMPORTANT: This Console requires selection of **US** (lane miles), **SI** [lane km], and **C-P** (Pulse Width Modulated), **C-Sd** (Standard Valve), **C-F** (Fast Valve), or **C-FC** (Fast Close Valve); and **SP1** (wheel drive, etc.), **SP2** (radar), or **SP3** (transmission) speed sensor.



Console Revision can be determined by the letter stamped in REV box on label.

Console Program can be determined by the letter stamped in PGM box on label.

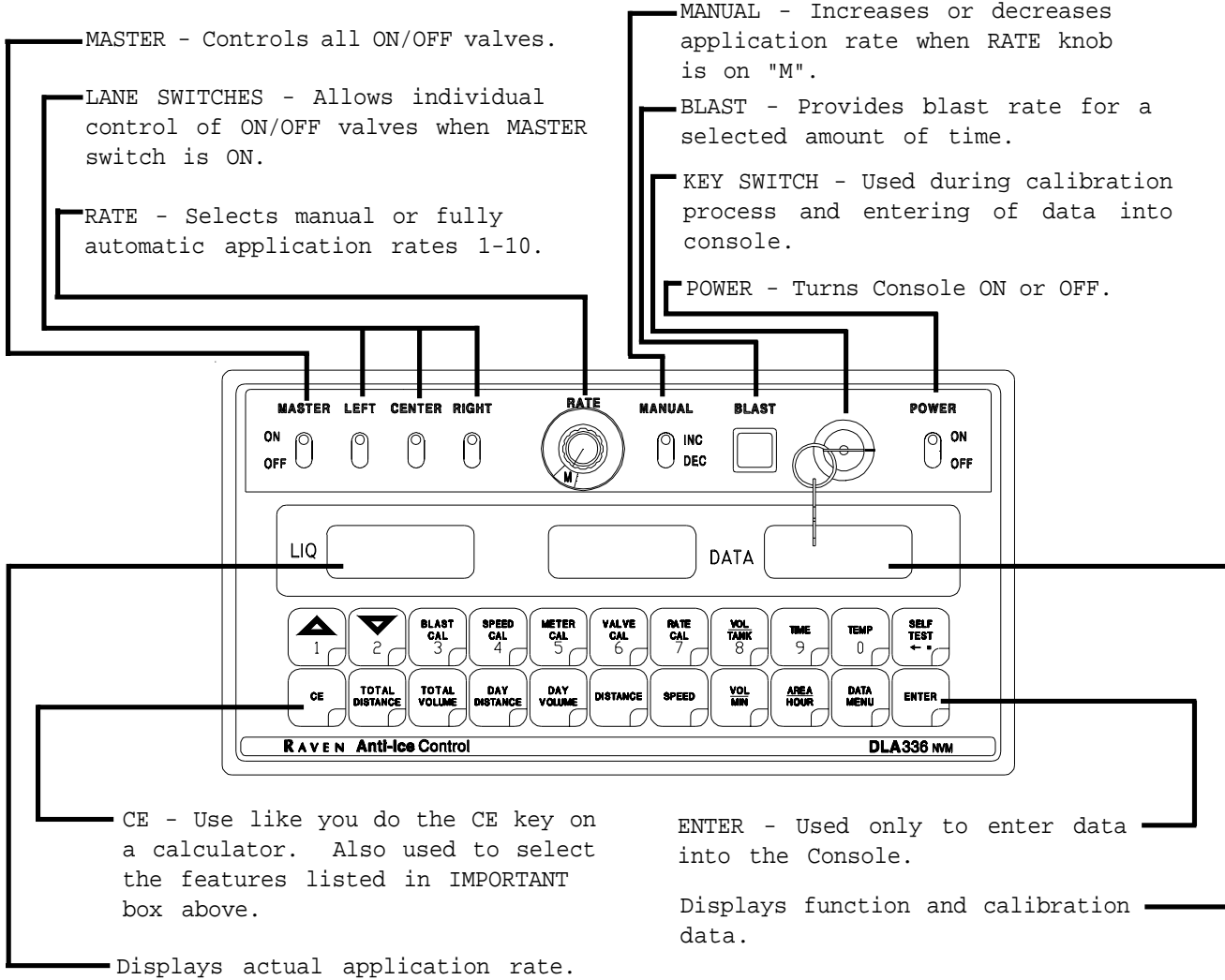

CALIBRATION KEYS -- Used to enter data into the Console to calibrate the system.

BLAST CAL -- Blast Rate and Blast Time

SPEED CAL -- Determined by Speed Sensor

METER CAL -- Flow Meter Calibration Number

VALVE CAL -- Valve Response Time

RATE CAL -- Desired Application Rate, Rates 1-10.

VOL/TANK -- Volume Remaining in Carrier Tank

TIME -- Time, Month, Day, Year, Power Down

TEMP -- Displays air and surface temperature

SELF TEST -- Simulates Vehicle Speed

FUNCTION KEYS -- Used to Display Data

TOTAL DISTANCE -- Total Distance

TOTAL VOLUME -- Total Volume Applied

DAY DISTANCE -- Day Distance

DAY VOLUME -- Day Volume Applied

DISTANCE -- Distance Traveled

SPEED -- Speed of Vehicle

VOL/MIN -- Volume per Minute

AREA/HOUR -- Area per Hour

DATA MENU -- Various Features and Data

CONSOLE PROGRAMMING

When entering data into the Console, the entry sequence is always the same.

NOTE: DATA MUST BE ENTERED INTO KEYS 3 THRU 7.

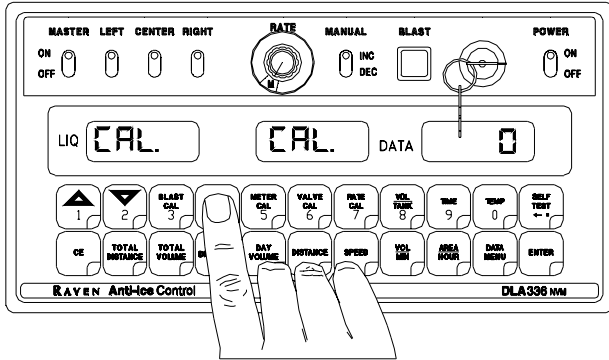

Depress the key in which you wish to enter data.

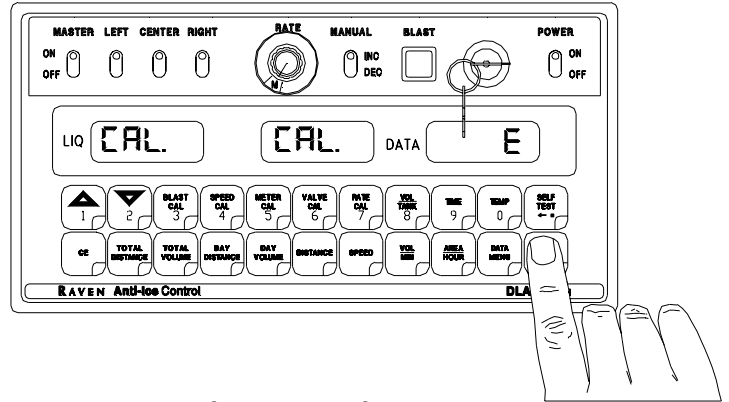

Depress the ENTER key. An "E" will illuminate in the DATA display.

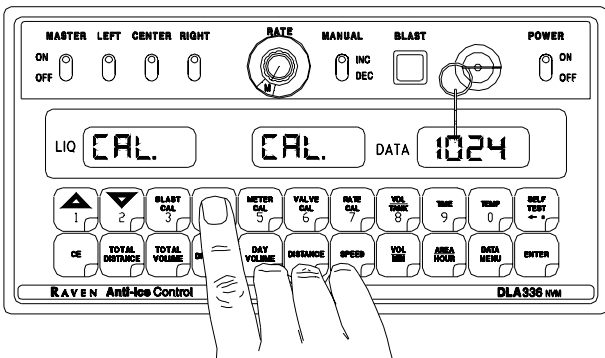

Depress the keys corresponding to the number you wish to enter (i.e. "1", "0", "2", "4"). The numbers will be displayed as they are entered.

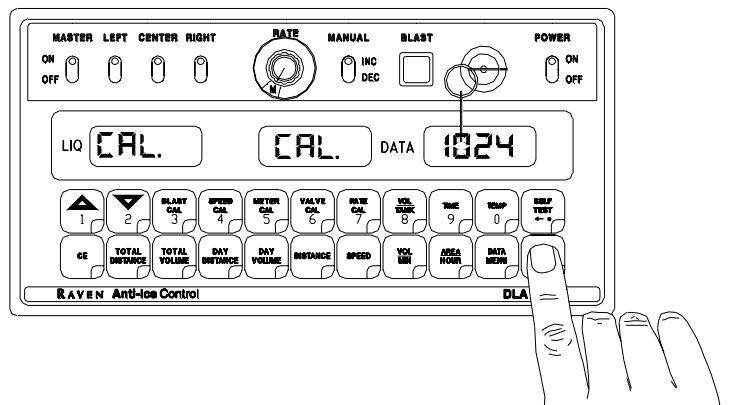

Complete the entry by again depressing the ENTER key.

1. INITIAL CONSOLE PROGRAMMING

Verify MASTER switch is OFF. After all installation procedures have been completed, turn POWER switch to on, the Console will flash "CAL" in the LIQ and DATA displays. This means that the Console must be "programed" before it can be operated. This is a one-time operation which does not have to be repeated. Turning OFF the POWER Switch or disconnecting power to the Console does not affect the Console memory. All data is retained in nonvolatile memory.

NOTE: The KEY switch must be in and turned to the horizontal position to enter data into the Console. This is referred to as the "programming mode".

Only the following keys are an exception:

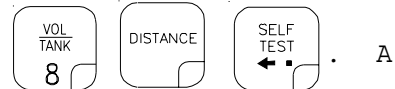

"0" (zero) may be entered for "day distance" and "day volume". Refer to 'Distance and Volume Displays' on page 14 for procedure.

The following steps must be followed for proper calibration:

1) Selecting US (lbs/mile), or SI (Kg/km).

a) To select US or SI, depress  until the desired selection is displayed in the DATA display.

b) Momentarily depress , the DATA display will now display SP1.

2) Selecting SP1 (drive shaft, wheel drive, etc.), SP2 (radar), or SP3 (transmission).



a) To select SP1, SP2, or SP3 depress  until desired selection is displayed.



b) Momentarily depress , the DATA display will now display C-P.

3) Selecting Control Valve type C-P (pulse width modulated) C-Sd (standard), C-F (fast), or C-FC (fast close).

a) To select C-P, C-Sd, C-F, or C-FC depress  until desired code is displayed.

b) Momentarily depress , the DATA display will now display "0".

- c) Depress and hold . The previous 3 settings that were selected will be displayed in the DATA display. Verify the selections made are correct before proceeding to the next step. If an error is noted, place POWER switch OFF, depress and hold , place POWER switch to GRAN, and repeat steps 1-3.

NOTE: For the remainder of the Console programming the  and  keys will be used advance through the various selections.



- 4) Enter the following values in . Depress  to advance through the BLAST CAL menu.

DISPLAY SCREENS			
<u>LIQ</u>	<u>DATA</u>		<u>PROCEDURE</u>
CAL	bL-r	0	Enter the desired Blast Rate (gal/mile) [lit/km].
CAL	bL-S	0	Enter the desired Blast Time (seconds).

- 5) Enter an initial value of "200" in . The actual SPEED CAL number will be obtained after initial programming is completed. Refer to section "CALCULATING SPEED CAL" for more instructions.

- 6) Enter the calibration number from flow meter tag in .

- 7) Enter VALVE CAL number based on selected control valve type in . C-P (53), C-Sd (2123), C-F (743), C-FC (743) refer to Appendix 2 page 29 for information to adjust this value if necessary.

- 8) Enter the following values in . Depress the  and  keys to advance through rates 1-10 ("r-01" through "r-10").

DISPLAY SCREENS			
<u>LIQ</u>	<u>DATA</u>		<u>PROCEDURE</u>
CAL	r-01	0	Enter the desired application rate (gal/mile) [lit/km].

YOU HAVE NOW COMPLETED INITIAL CONSOLE PROGRAMMING.
The flashing "CAL" will now extinguish. If not, repeat procedure starting at Step 4.

CONSOLE CALIBRATION

1. CALCULATING OFFSETS

The offsets need to be set if the system is controlled by a PWM Valve and C-P was selected during initial console programming.

1) ANTI-ICE HIGH OFFSET

a) LIQ display will show "oFS". Left DATA display will show "Anhi". Right DATA display will show "254".

b) Depress  .

c) Depress  to start running the liquid pump. The vol/min of liquid and "Anhi" will alternately be displayed in the left DATA display.

While liquid pump is running, depress and hold  until the vol/min

begins to decrease. Depress  to slowly increase the vol/min until the maximum vol/min is noticed, then increase offset value displayed in the right DATA display by an additional 10.

d) After desired offset value is set, depress  . HIGH OFFSET is now set.



e) Depress  to advance to ANTI-ICE LOW OFFSET.

2) ANTI-ICE LOW OFFSET

a) LIQ display will show "oFS". Left DATA display will show "AnLo". Right DATA display will show "2".

b) Depress  .

c) Depress  and the liquid pump will stop running. The vol/min of the liquid and "AnLo" will alternately be displayed in the left DATA display.

Depress and hold  until the pump starts running. Use  to slowly decrease the vol/min until "0000" is displayed, then decrease offset value displayed in the right DATA display by an additional 10.

d) After desired offset value is set, depress . LOW OFFSET is now set.

e) Depress  to advance to ANTI-ICE HIGH OFFSET.

2. CALCULATING "SPEED CAL"



1) Depress  until the LIQ display shows "CAL". The left DATA display will show "SPeD". Right DATA display will show "on" or "oFF".

2) Momentarily depress  to turn CAL speed "on".

3) Depress .

4) While driving the vehicle at normal operating speed, depress the  and

 keys to match the speed displayed in the DATA display to the speedometer of the truck.

5) When matched, depress  and depress  to turn CAL speed "oFF" when calibrated.

6) Depress  and record value for future reference.

NOTE: This is not an exact reading. For a more accurate calibration or for radar speed calibration refer to Appendix 1, Section 2 for "CALCULATING SPEED CAL".

OTHER CONSOLE FEATURES

1. VOL/TANK

This feature allows the operator to monitor the amount of liquid remaining in the tank. Enter the volume of liquid (gal)[lit] in the tank in  and the console will decrease the volume as the liquid is being applied. This volume must be entered each time tank is filled.

2. LOW TANK ALARM

This feature will sound the alarm when the liquid volume drops below an entered value. If the liquid volume falls below the low tank value entered, the alarm will sound 8 beeps every 15 seconds and LIQ display screen will flash "LEul". The alarm will stop when a value equal to or greater than the Low Tank Alarm value is entered into VOL/TANK, or the MASTER switch is turned OFF. Entering "0" into Low Tank Alarm disables the alarm.

a) Depress  until the right DATA display flashes.

b) To enter a value, depress , LOW TANK ALARM value, and .

NOTE: Go to DATA MENU to silence audible alarm.

3. LOW TANK LEVEL SHUT-OFF

This feature automatically closes the lane valves when the tank volume reaches the Low Tank Alarm. The valves will automatically open when a value greater than the Low Tank Alarm value is entered into VOL/TANK. Refer to DATA MENU MISCELLANEOUS SCREENS for procedure to use this feature.

4. ZERO SPEED SHUT-OFF

This feature automatically closes the lane valves when the consoles registers zero speed. The valves will automatically open when a speed registers in the console. Refer to DATA MENU MISCELLANEOUS SCREENS for procedure to use this feature.

5. TIME

Displays time, month, day, year, and power down feature. Depress . To

advance through the categories depress .

<u>LIQ</u>	<u>DISPLAY SCREENS</u>		<u>DESCRIPTION</u>
	<u>DATA</u>		
0000	tiNE	00:00	Time-24 hour clock. Example: 2:30 p.m. = 14:30
0000	onth	1	Month (1 = January, 2 = February, etc.)
0000	dAY	1	Day
0000	YEAr	00	YEAR.
0000	Pdn	30	Powerdown feature defaulted to 30 days.

6. TEMP

This feature allows the operator to view the air and road surface temperatures. A temperature sensor and interface cable must be installed. Consult your dealer



or Raven Industries for more information. Depress . To advance through

the categories depress .

<u>LIQ</u>	<u>DISPLAY SCREENS</u>		<u>DESCRIPTION</u>
	<u>DATA</u>		
0000	tENP	oFF	Selects on or off for temperature feature.
0000	nodE	FAR	Selects Fahrenheit or Celsius.
0000	A000	P000	Displays air (A) and road surface (P) temperatures.

NOTE: Baud Rate must be set to 9600. See page 21.

7. SELF TEST FEATURE

- 1) SELF TEST allows speed simulation for testing the system while the vehicle is not moving. Enter the simulated operating speed in . If 6 MPH [9.6 km/h] is desired, enter 6.0 [9.6] (See CONSOLE PROGRAMMING). Verify speed by depressing , 6.0 [9.6] will appear in the right DATA display. The SELF TEST speed will clear itself when motion of the vehicle is detected by the Speed Sensor. The speed displayed may be different than the self test speed entered depending on the SPEED CAL value.

NOTE: To prevent nuisance clearing of self-test speed, disconnect speed connector on back of the Console.

- 2) Display the Console set-up selections depress and hold . DATA display will cycle through the set-up selections (US or SI, SP1, SP2, SP3, C-P, C-Sd, C-F, or C-FC).
- 3) The following is an example on how to use the DLA 336 as a troubleshooting tool. When placed in the self-test mode it allows the operator and technician to duplicate system operation.

EXAMPLE:

To determine the maximum application rate that the truck is capable of applying at a given speed.

- 1) Depress . Enter a self-test speed of 25 mph.
- 2) Place the RATE knob to the "M" position.
- 3) Use the INC switch until application rate in the LIQ display no longer increases.
- 4) The rate in the LIQ display is the maximum application rate at 25 mph.
- 5) Enter a self test speed of 30 mph and the LIQ display will show the maximum application rate for that speed.
- 6) Repeat this procedure of increasing the speed to obtain all maximum application rates at specific speeds.

EXAMPLE:

The operator wants to travel at 30 mph and apply a rate of 80 gallons per mile. After performing the procedure stated above it was determined that the maximum application rate at 30 mph was 70 gallons per mile. At that speed and rate the system of the truck is at the maximum capacity. The following are some possible choices to increase the capacity; 1) decrease the vehicle speed, 2) accept a lower application rate at that speed, 3) increase output of liquid pump if possible, 4) change nozzles, 5) utilize tier capability.

8. DISTANCE & VOLUME DISPLAYS

- 1) To display the total distance traveled while applying material depress



. To clear this value the key must be turned to the horizontal position and then enter "0".

- 2) To display the total volume of material applied depress . To clear this value the key must be turned to the horizontal position and then enter "0".

- 3) To display the distance traveled while applying material during day, event, etc. depress . To clear this value enter "0".

- 4) To display the distance traveled while applying material during day, event, etc. depress . To clear this value enter "0".

- 5) To display distance (feet)[meters] traveled depress .

9. VOL/MIN & LOW LIMIT FLOW ALARM

Displays volume/minute, low limit alarm, and tier functions. Depress



To advance through the categories depress



<u>LIQ</u>	<u>DISPLAY SCREENS</u>		<u>DESCRIPTION</u>
	<u>DATA</u>		
0000	FLAn	.0	Actual volume/minute of system.
0000	LLAn	.0	Low Limit Flow Alarm value. Volume/minute in which alarm is turned on.
0000	tir2	.0	Tier 2 Enable Value. Volume/minute value in which tier 2 valve will open.
0000	tir3	.0	Tier 3 Enable Value. Volume/minute value in which tier 3 valve will open.
0000	bAnd	10	Tier Disable Percentage.

Low Limit Flow Alarm

Example:

- 1) Place RATE knob to the lowest application rate, typically this will be RATE 1.
- 2) Enter a SELF TEST speed.
- 3) Observe the volume/minute ("FLAn").
- 4) Enter a lower SELF TEST speed.
- 5) Repeat steps 3 & 4 until the lowest acceptable spray pattern is reached.
- 6) Record minimum volume/minute when the spray pattern is acceptable. Enter this value for the minimum flow ("LLAn").

Tier Enable

Example:

Main spray bar capacity	-	15 (gal/min) [lit/min]
Tier 2 capacity	-	30 (gal/min) [lit/min]
Tier 3 capacity	-	60 (gal/min) [lit/min]
Total System capacity	-	105 (gal/min) [lit/min]

Set Tier 2 Enable at 15 (gal/min)[lit/min](main spray bar)Set Tier 3 Enable at 45 (gal/min)[lit/min](main spray bar + tier 2)Percentage tier disable default is 10%. In this case, tier 2 would be enabled at 15.0 (gal/min)[lit/min] and disabled at 13.5 (gal/min)[lit/min]. Tier 3 would be enabled at 45.0 (gal/min) [lit/min] and disabled at 40.5 (gal/min) [lit/min].

10. AREA/HOUR

Displays number of lane miles being covered per hour. If lane width is zero then the area per hour value will also be zero.

11. BLAST BUTTON

- 1) Depressing the BLAST button will cause the system to go to the programmed Blast Rate. The system will remain at the Blast Rate for as long as the button is depressed plus the programmed Blast Time after the button is released. If the BLAST button is used with zero speed the Console will assume a speed of 5 MPH [7 Km/hr].
- 2) To display the number of times the BLAST feature was used, depress and hold



for 5 seconds until right DATA display flashes. To zero this total, enter a "0".

12. CONTROL VALVE DELAY



Depress until the right DATA display flashes. The first digit,

(0 0 0), is the Control Valve delay digit. This feature allows the user to set a delay between the time the MASTER is turned on and when the Console begins to control the application rate. A value of 1-9 means a delay of 1-9 seconds respectively. A value of 0 means no delay.

13. AUTOMATIC RATE +/-

This feature allows an increment to be set at which flow may be increased or decreased while in automatic operation (rates 1-10). To select RATE +/- depress



until the right DATA display flashes. To enter a value depress



increment value, and . When using this feature the preprogrammed application rates will be changed accordingly.

EXAMPLE: If application rate is to change by "10":

Enter a value of 10 for RATE +/- . When in RATES 1-10, each time the MANUAL INC/DEC switch is positioned to INC, the RATE will increase by "10". Likewise, when positioned to DEC, the RATE will decrease by "10".

14. MANUAL MODE LOCK OUT

If the key switch is in the vertical position (operate mode) and the Manual Control is off (see DATA MENU); the manual position (M) of the RATE knob will only function under two (2) conditions:

- 1) No speed (typical scenario to unload truck).
- 2) No flow signal.

With the RATE knob placed to the manual position (M) the Console will default to RATE 1 unless the above conditions exist. If the key is in the horizontal position (program mode); **OR** the key is vertical and the manual control is ON (see DATA MENU); the manual position (M) is active for all conditions. Using the MANUAL INC/DEC switch will increase or decrease your application rate.

DATA MENU

DEFINITION OF DATA MENU KEYS:



Depressing this key displays the selected Data Menu category in the LIQ display.



Depressing this key again increments through the Data Menu categories ("SPr", "GPS", "dAtE", etc...) in the LIQ display.









Depressing this key (after desired category is shown in LIQ display) advances up through desired features within a category. Selected feature is shown in the left DATA display.



Depressing this key (after desired category is shown in LIQ display) advances down through desired features within a category. Selected feature is shown in the left DATA display.

SERIAL PORT SCREENS

CONSOLE DATA PRINTOUT

- a) LIQ display will show "SPr". Left DATA display will show "Prn". Right DATA display will show "CAL". To print calibration numbers, depress .
- b) Depress  to advance to print begin. LIQ display will show "SPr". left DATA display will show "Prn". Right DATA display will show "bEGn". To print beginning totals, depress .
- c) Depress  to advance to print end. LIQ display will show "SPr". left DATA display will show "Prn". Right DATA display will show "End". To print ending totals, depress . While "End" is in the right DATA display; if a beginning total or calibration numbers printout is required, depress  to advance the right DATA display to "bEGn" or "CAL".



NOTE: If "End" is printed and a CAL number has been changed, a warning will be printed (print CAL to see which number has changed).

- d) Depress  to advance to TRUCK NUMBER.



TRUCK NUMBER

- a) LIQ display will show "SPrt". Right DATA display will show "0". The truck number can be entered in as 8 digits or less.
- b) Enter the truck number.
- c) Depress  to advance to BAUD RATE.

BAUD RATE

- a) LIQ display will show "SPr". Left DATA display will show "bAUd". Right DATA display will show "1200".
- b) Depressing  steps the DATA display between "1200" and "9600".
- c) Depress  to advance to RATE CHANGE ALARM.

RATE CHANGE ALARM

- a) LIQ display will show "SPr". Left DATA display will show "rAtE". Right DATA display will show "on".
- b) Depressing  steps the right DATA display between "on" and "oFF". A value of "on" means alarm is enabled; a value of "oFF" means alarm is disabled.
- c) Depress  to advance to DATA LOGGER TRIGGER VALUES.

DATA LOGGER TRIGGER VALUE

- a) LIQ display will show "SPr". Left DATA display will show "triG". Right DATA display will show "0".
- b) Enter the TRIGGER VALUE.
- c) Depress  to advance to DATA LOGGER TRIGGER UNITS.



IMPORTANT: The TRIGGER VALUE default value is "0". This value **must** be changed to a desired number ranging from 1-9999. The DATA LOGGER features will not work if this number is "0".

DATA LOGGER TRIGGER UNITS

- a) LIQ display will show "SPr". Left DATA display will show "Unit". Right DATA display will show "Ft"["MEtr"].
- b) Depressing  steps the right DATA display between "Ft"["MEtr"] and "SEC". A value of "Ft"["MEtr"] means feet [meters], or a value of "SEC" means seconds have been chosen as the unit of measurement for the TRIGGER VALUE programmed previously.

- c) Depress  to advance to DATA LOGGER.

DATA LOGGER

- a) The DATA LOGGER uses the communications strings to pass data out through the serial port. The data is sent at a set time interval or a set distance traveled, as determined by the values entered in the DATA LOGGER TRIGGER VALUE and DATA LOGGER TRIGGER UNITS. Upon each trigger, the Actual Rate string, Data Strings 1, 2, 3, 4, and 5, and the Time/date string are sent, in that order. When a Console calibration value is changed, the Console will automatically send out the Cal 1, 2, and 3 strings. When a Console switch is changed, the Data 1, 2, 3, 4, 5, Time/Date, and Cal 1, 2, 3, strings will be sent by the Console. The Data, (with Time/Date string included) and Cal strings can also be requested by the data logger using the request strings.
- b) LIQ display will show "SPr". Left DATA display will show "dLoG". Right DATA display will show "oFF".
- c) Depressing  steps the right DATA display between "oFF" and "on". A value of "oFF" means DATA LOGGER is disabled; a value of "on" means DATA LOGGER is enabled.
- d) Depress  to advance to CONSOLE DATA PRINTOUT.
- e) Depress  to advance to the GLOBAL POSITIONING SYSTEM SCREENS.

GLOBAL POSITIONING SYSTEM SCREENS

GPS SYSTEM OPTIONS



- a) GPS is inactive when the LIQ display shows "GPS", the left DATA display shows "SYSt", and the right DATA display shows "inAC". The console must be in this mode if connected to a temperature sensor and not connected to a GPS system.
- b) Depress  to advance to the ALARM SCREENS.

ALARM SCREENS

AUDIBLE ALARM



The DLA 336 has several alarm indicators. The alarms can be turned on or off to accommodate the operators preference.

- a) LIQ display will show "ALr". Left DATA display will show "ALrM". Right DATA display will show "on".

- b) Depressing  steps the right DATA display between "on" and "off". A setting of "on" enables the audible alarm; a setting of "oFF" disables the audible alarm.
- c) Depress  to advance to LIQUID OFF RATE ALARM.

LIQUID OFF RATE ALARM

Alarm sounds and LIQ display will show "or" when the actual rate is off from the application rate by a specified percentage for 5 seconds. The off rate value is preset to 30%, but may be changed to a different number. A value of "0" will disable this alarm.

- a) LIQ display will show "ALr". Left DATA display will show "Lior". Right DATA display will show 30.
- b) Depress  to advance to AUDIBLE ALARM.
- c) Depress  to advance to MISCELLANEOUS SCREENS.

NO SPEED ALARM

This sounds if the MASTER switch is ON, the RATE knob is on 1-10, and there is a no ("0") speed detected.

- a) The NO SPEED ALARM sounds 3 beeps every 8 seconds.

NOTE: When operating in C-P or C-FC valve mode the console has an automatic control valve zero speed shut off feature. The NO SPEED ALARM will sound in this case. The alarm will discontinue when vehicle begins moving.

CAUTION: Do not rely on zero speed shut off when performing maintenance on vehicle. A stray speed signal could suddenly turn the system on, especially when a radar speed sensor is being used.



LOW TANK ALARM

This sounds when the VOL/TANK reaches the programmed alarm level (See OTHER CONSOLE FEATURES).



- a) This alarm sounds 8 beeps every 15 seconds. The console automatically displays "LEuL" in the LIQ display screen when tank volume has reached the alarm level.
- b) Depress VOL/TANK key for 5 seconds until right DATA display flashes and enter a "0" to disable this feature.

MISCELLANEOUS SCREENS



DISPLAY SMOOTHING

- a) LIQ display will show "MiSC". Left DATA display will show "diSP". Right DATA display will show "on".
- b) Depressing  steps the right DATA display between "on" and "oFF". A setting of "on" means smoothing is enabled; a setting of "oFF" means smoothing is disabled, therefore the actual liquid rates will be displayed at all times. The percent smoothing is determined by the third digit of the VALVE CAL value.
- c) Depress  to advance to MANUAL CONTROL.

MANUAL CONTROL

- a) LIQ display will show "MiSC". Left DATA display will show "MAn". Right DATA display will show "oFF".
- b) Depressing  steps the right DATA display between "on" and "oFF".
A setting of "on" enables manual control when the key switch is in the vertical position, a setting of "oFF" disables manual control when key switch is in the vertical position.
- c) Depress  to advance to LOW TANK LEVEL SHUT-OFF.



LOW TANK LEVEL SHUT-OFF

- a) LIQ display will show "MiSC". Left DATA display will show "LeuL". Right DATA display will show "oFF".
- b) Depressing  steps the right DATA display between "on" and "oFF".
A setting of "on" enables the console to automatically close the lane valves when the tank volume reaches the low tank alarm. Values must be entered for VOL/TANK and LOW TANK ALARM for this feature to function properly. A setting of "oFF" disables this feature.
- c) Depress  to advance to ZERO SPEED SHUT-OFF.

ZERO SPEED SHUT-OFF

- a) LIQ display will show "MiSC". Left DATA display will show "AUto". Right DATA display will show "oFF".
- b) Depressing  steps the right DATA display between "on" and "oFF".
A setting of "on" enables the console to automatically close the lane valves

when the console registers zero speed. When speed is registered by the console the lane valves will automatically open. A setting of "oFF" disables this feature.





- c) Depress  to advance to DISPLAY SMOOTHING.
- b) Depress  to advance to OFFSET SCREENS.

OFFSET SCREENS

- a) See pages 12, and 13 for OFFSET SCREENS.
- b) Depress  to advance to CAL SCREENS.

CAL SCREENS

CAL SPEED

- a) LIQ display will show "CAL". Left DATA display will show "SPed". Right DATA display will show "on or oFF".
- b) Depress  to turn CAL speed to "on". This will allow the use of the  and  keys to match the speed of the truck with the console.
Depress  to turn CAL speed to "oFF" when calibrated.

NOTE: This is not an exact reading. See Appendix 1, section 2 "CALCULATING SPEED CAL" for further instructions.

- c) Depress  to advance to CAL 2 SPEED.

CAL 2 SPEED

NOTE: The 2 speed wire has to be hooked up to the 2 speed enable on truck.

- a) LIQ display will show "CAL". Left DATA display will show "LSPd". Right DATA display will show "0.00".
- b) Enter in the low gear ratio as indicated on the line sheet or tag.
- c) Depress . LIQ display will show "CAL". Left DATA display will show "hSPd". Right DATA display will show "0.00".
- d) Enter the high gear ratio as indicated on the line sheet or tag.

- e) Depress  to advance to COIL FREQUENCY.

COIL FREQUENCY

- a) LIQ display will show "CAL". Left DATA display will show "FrEq". Right DATA display will show "180".
- b) Enter in the frequency of the PWM valve (16 hz to 4000 hz). **As specified by the manufacture of the Hydraulic Valve.** Refer to Appendix 2 for recommended values for different coil types.

- c) Depress  to advance to CAL SPEED.

- d) Depress  to advance to LANE SCREENS.

LANE SCREENS

LANE WIDTH

- a) LIQ display will show "LANE". Left DATA display will show "LANE". Right DATA display will show "12".
- b) Enter the lane width (feet)[m] if desired application rate is gal/lane mile or lit/lane km. If desired application rate is gal/mile or lit/km enter "0".
- c) If a lane width was entered depress  to advance to LEFT LANE WIDTH.

LEFT LANE WIDTH



- a) LIQ display will show "LANE". Left DATA display will show "LEFt". DATA display will show "144".
- b) Enter the left lane width (inches)[cm].
- c) Depress  to advance to CENTER LANE WIDTH.

CENTER LANE WIDTH



- a) LIQ display will show "LANE". Left DATA display will show "Cntr". Right DATA display will show "144".
- b) Enter the center lane width (inches)[cm].
- c) Depress  to advance to RIGHT LANE WIDTH.

RIGHT LANE WIDTH

- a) LIQ display will show "LANE". Left DATA display will show "rGht". Right DATA display will show "144".
- b) Enter the right lane width (inches)[cm].

- c) Depress  to advance to LANE WIDTH.
- d) Depress  to advance to BLAST SCREENS.

BLAST SCREENS

- a) Displays blast day distance, total distance, day volume, and total volume for product.
- b) Depress  to advance through blast screens.
- c) Depress  to advance to SERIAL PORT SCREENS.

APPENDIX 1

SPEED SENSOR CALIBRATION PROCEDURE

1. CALCULATING "SPEED CAL"

1) Complete "INITIAL CONSOLE PROGRAMMING" before doing this procedure.

2) Enter "0" in .

3) Enter a SPEED CAL of 300 for transmission sensors or 598 radar sensor in .

4) Drive 1 mile [1 km].

CAUTION: Do not use vehicle odometer to determine distance. Use section lines or highway markers, or measured distance.

5) Read DISTANCE by depressing .

- a) DISTANCE should read a value of approximately 5280 [1000]. If it reads between 5200-5350 [990-1010], the SPEED CAL for your vehicle is 612 [155].
- b) If the DISTANCE display reads any other value, perform the following calculation:

Multiply the SPEED CAL by the known distance reading, then divide the sum by the actual value in DISTANCE display. This will give you the corrected value to enter for SPEED CAL. **You must round off to the nearest 3 digit whole number.**

EXAMPLE: SPEED CAL = 612 [155]
 Known distance reading = 5280 [1000]
 Assume the actual DISTANCE display reads 5000 [980]

ENGLISH UNITS:	METRIC UNITS:
= $\frac{612 \times 5280}{5000} = 646.3$	= $\frac{[155] \times [1000]}{[980]} = [158.1]$

6) The corrected number to enter for SPEED CAL is 646 [158].

7) Verify the corrected SPEED CAL number calculated above:

- a) Zero out the DISTANCE display as in Step 2.
- b) Enter the corrected SPEED CAL number as in Step 3.
- c) Repeat Steps 4 and 5a. If DISTANCE value does not read correctly repeat Steps 5b, 6, and 7.

APPENDIX 2 CALCULATING "LIQ VALVE CAL"

- 1) After operating the system, you may desire to refine this number. See definitions below:

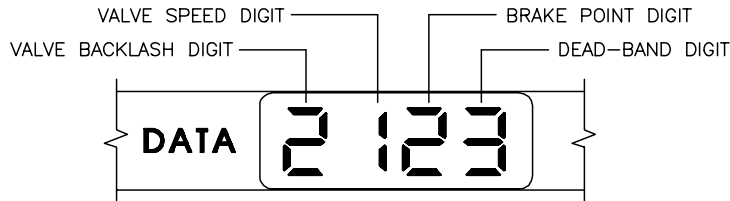

Valve Backlash Digit -- Controls the time of the first correction pulse after a change in correction direction is detected. (INC to DEC -or- DEC to INC).

Range: 1 to 9 1-Short Pulse, 9-Long Pulse

Valve Speed Digit -- Controls response time of Control Valve motor.
CAUTION: Running the Control Valve too fast will cause the system to oscillate.

C-P/C-Sd	Valve Control	Range: 0 to 9	0-Slow, 9-Fast
C-F/C-FC	Valve Control	Range: 0 to 9	0-Fast, 9-Slow

Brake Point Digit -- Sets the percent away from target rate at which the Control Valve motor begins braking, so as not to overshoot the desired rate.

Range: 0 to 9 0 = 5%, 1 = 10%, 9 = 90%

Dead-Band Digit -- Allowable difference between target and actual application rate, where rate correction is not performed.

Range: 1 to 9 1 = 1%, 9 = 9%







<u>MANUFACTURER</u>	<u>VALVE CAL NUMBER</u>	<u>COIL FREQUENCY</u>
Brand	136	90-115
Compact	145	100
Energy	136	90-115
Gresen	125	50
Hydroforce	136	100-150
Rexroth	73	180-200

APPENDIX 3 ENTERING OFFSET VALUES





To enter known or previously obtained offsets without engaging the hydraulic system of the vehicle the operator must perform the following procedure.

NOTE: When setting offsets the MASTER switch must be ON, and the RATE knob must be on "M".

1) ANTI-ICE HIGH OFFSET

- a) Depress  until LIQ display shows "oFS". Left DATA display will show "Anhi". Right DATA display will show "254".
- b) Depressing  allows the user to use the  and  keys to set to offset value desired.
- c) After desired value is set, depress . HIGH OFFSET is now set.
- d) Depress  to advance to LOW OFFSET.

2) ANTI-ICE LOW OFFSET

- a) LIQ display will show "oFS". Left DATA display will show "AnLo". DATA display will show "2".
- b) Depressing  allows the use of the  and  keys to set the offset value desired.
- c) After desired value is set, depress . LOW OFFSET is now set.
- d) Depress  to advance to HIGH OFFSET.

APPENDIX 4

PROCEDURE TO TEST SPEED SENSOR EXTENSION CABLES

Disconnect extension cable from Speed Sensor Assembly cable. Hold extension cable connector so that keyway is pointing in the 12 o'clock position.

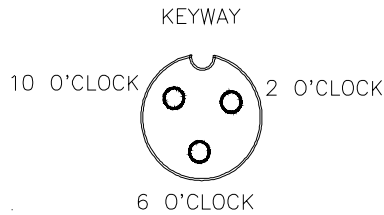

PIN DESIGNATIONS

2 o'clock socket location is power.
10 o'clock socket location is ground.
6 o'clock socket location is signal.

VOLTAGE READINGS

- 1) 10 o'clock socket to 6 o'clock socket = +5 VDC.
- 2) 10 o'clock socket to 2 o'clock socket = +5 VDC or +12 VDC (RADAR).

If a +5 VDC voltage reading is not present, disconnect the Flow Sensor cable. If the Speed reading is restored, Test the Flow Sensor cable per Appendix "PROCEDURE TO TEST FLOW METER CABLES".

PROCEDURE TO CHECK CABLE:

- 1) Enter SPEED CAL number of 9999 in



- 2) Depress



- 3) With small jumper wire (or paper clip), short between the 10 o'clock and 6 o'clock sockets with a "short-no short" motion. Each time a contact is made, the DISTANCE total should increase by increments of 1 or more counts.
- 4) If DISTANCE does not increase, remove the section of cable and repeat test at connector next closest to Console. Replace defective cable as required.
- 5) Perform above voltage checks.
- 6) If all cables test good, replace Speed Sensor.

NOTE: After testing is complete, re-enter correct SPEED CAL number before application.

APPENDIX 5

PROCEDURE TO TEST FLOW METER CABLES

Disconnect cable from Flow Sensor. Hold Flow Sensor cable so that the keyway is pointing in the 12 o'clock position:

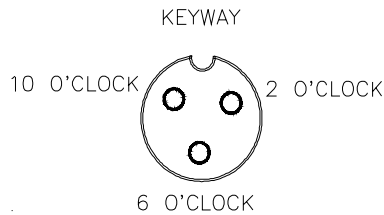

PIN DESIGNATIONS





2 o'clock socket location is ground.
10 o'clock socket location is power.
6 o'clock socket location is signal.

VOLTAGE READINGS

- 1) 2 o'clock socket to 6 o'clock socket = +5 VDC.
- 2) 2 o'clock socket to 10 o'clock socket = +5 VDC.

If a +5 VDC voltage reading is not present, disconnect the Speed Sensor cable. If the Flow reading is restored, Test the Speed Sensor cable per Appendix "PROCEDURE TO TEST SPEED SENSOR EXTENSION CABLES".

PROCEDURE TO CHECK CABLE:

- 1) Enter a METER CAL number of one (1) in  for granular cable;  for liquid cable.
- 2) Depress  for granular cable;  for liquid cable.
- 3) Place MASTER switch to ON, POWER switch to GR/LI, and enter self test speed of 5 mph.
- 4) With small jumper wire (or paper clip), short between the 2 o'clock and 6 o'clock sockets with a "short-no short" motion. Each time a contact is made, the TOTAL VOLUME should increase by increments of 1 or more counts.
- 5) If TOTAL VOLUME does not increase, remove the section of cable and repeat test at connector next closest to Console. Replace defective cable as required.
- 6) Perform above voltage checks.
- 7) If all cables test good, replace Flow Sensor.

NOTE: After testing is complete, re-enter correct METER CAL numbers before application.



APPENDIX 6

FLOW METER MAINTENANCE AND ADJUSTMENT PROCEDURE

- 1) Remove Flow Meter from pre-wet system and flush with clean water to remove any chemicals.
- 2) Remove flange bolts or clamp from the Flow Meter.
- 3) Remove the turbine hub and turbine from inside Flow Meter.
- 4) Clean turbine and turbine hub of metal filings or any other foreign material, such as wettable powders. Confirm that the turbine blades are not worn. Hold turbine and turbine hub in your hand and spin turbine. The turbine should spin freely with very little drag inside the turbine hub.
- 5) If transducer assembly is replaced or if turbine stud is adjusted or replaced, verify the turbine fit before reassembling. Hold turbine hub with turbine on transducer. Spin turbine by blowing on it. Tighten turbine stub until turbine stalls. Loosen turbine stud 1/3 turn. The turbine should spin freely.
- 6) Re-assemble Flow Meter.
- 7) Using a low pressure (5 psi) [34.5 kPa] jet of air, verify the turbine spins freely. If there is drag, loosen hex stud on the bottom of turbine hub 1/16 turn until the turbine spins freely.
- 8) If the turbine spins freely and cables have been checked per Appendix "PROCEDURE TO TEST FLOW CABLES", but Flow Meter still is not totalizing properly, replace Flow Meter transducer.

APPENDIX 7

PROCEDURE TO RE-CALIBRATE FLOW METER

- 1) Enter a LIQ METER CAL number of 10 [38] in  .
- 2) Enter a TOTAL LIQ VOLUME of 0 in  .
- 3) Place MASTER switch to OFF.
- 4) Remove a boom hose and place in calibrated 5 gallon [19 liter] container.
- 5) Place POWER switch to GR/LI and MASTER switch to ON. Enter a self test speed of 5 mph. Pump exactly 10 gallons [38 liters].
- 6) Readout in DATA display is the new METER CAL number. This number should be within +/-3% of the number stamped on the tag on Flow Meter.
- 7) Repeat this procedure several times to confirm accuracy. (Always "zero out" the TOTAL LIQ VOLUME display before retesting).

NOTE: For greatest precision, set METER CAL to 100 and pump 100 gallons (378 liters) of water.

- 8) To verify Flow Meter calibration, fill applicator tank with a predetermined amount of measured liquid (i.e. 250 gallons). **DO NOT RELY ON GRADUATION NUMBERS MOLDED INTO APPLICATOR TANK.** Empty the applicator tank under normal operating conditions. If the number displayed under TOTAL LIQ VOLUME is different from the predetermined amount of measured liquid by more than +/-3%, complete the following calculation.

EXAMPLE:

LIQ METER CAL	=	720 [190]
TOTAL LIQ VOLUME	=	260 [984]
Predetermined amount of measured liquid	=	250 [946]

Corrected METER CAL = $\frac{\text{LIQ METER CAL} \times \text{TOTAL LIQ VOLUME}}{\text{Predetermined amount of measured liquid}}$

ENGLISH UNITS:	METRIC UNITS:
= $\frac{720 \times 260}{250} = 749$	= $\frac{[190] \times [984]}{[946]} = [198]$

Corrected LIQ METER CAL = 749 [198]

- 9) Enter corrected LIQ METER CAL before resuming application.

NOTE: For RFM 200 series Flow Meter, use old METER CAL number of 164 [43] and calibrate as described in Step 8.

APPENDIX 8

REMOTE SWITCH OPTIONS

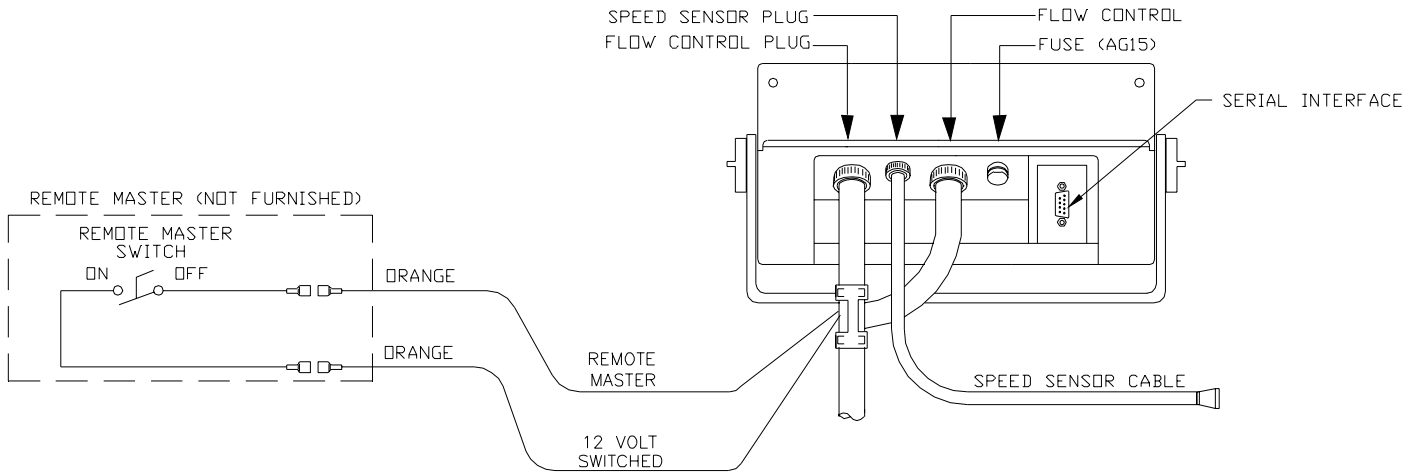

FIGURE 8

REMOTE MASTER

The REMOTE MASTER supplies power to the MASTER switch. Therefore switching the REMOTE MASTER ON when the MASTER switch is in the ON position will energize the liquid applicator. The REMOTE MASTER only switches on the applicator.

INSTALLATION

To install a REMOTE MASTER, locate the solid orange wire within the console cable. Cut the orange wire and use both ends to install the REMOTE MASTER as shown in Figure 8.

APPENDIX 9

INSTALLATION OF RAVEN RADAR

For mounting the Radar, the following guidelines will assure proper installation: It is suggested that a large heavy mounting bracket, (P/N 107-0159-693) be attached to the vehicle frame for mounting the Radar. (See Appendix 1 for Speedometer Speed Sensor installation instructions).

- 1) Park vehicle on level surface.
- 2) Select mounting site by considering the following:
 - a) The line of sight from the lens to the ground must not be obstructed by structures or tires. Road surface must not come closer than 20 inches to the bottom of the Radar. See Figures 9 and 10.
 - b) The Radar lens must be parallel to the ground from front to back. Radar can be tilted out 0-15 degrees to provide more clearance and miss obstructions. See Figure 10.
 - c) The Radar should be mounted so that the **length** of the Radar is **parallel** with direction of vehicle travel.
- 3) Use carpenters level to verify that mounting bracket is parallel to the ground.
- 4) Bolt mounting bracket to vehicle.
- 5) Bolt Radar to mounting bracket using mounting hardware. See Figure 11.
- 6) Connect Radar with Radar Interface Cable (P/N 115-0159-539), to the DCS 700 Console. The Red wire should be connected to switched 12VDC power. The White wire should be connected to the ground.

CAUTION: The connection of the Radar power in reverse polarity could result in damage to the Radar.

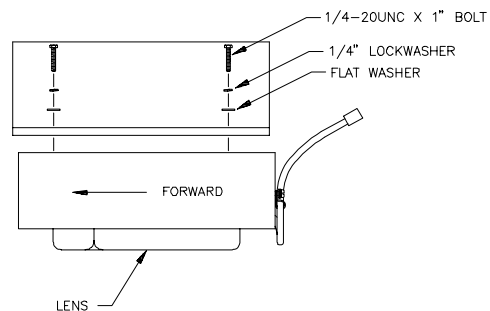
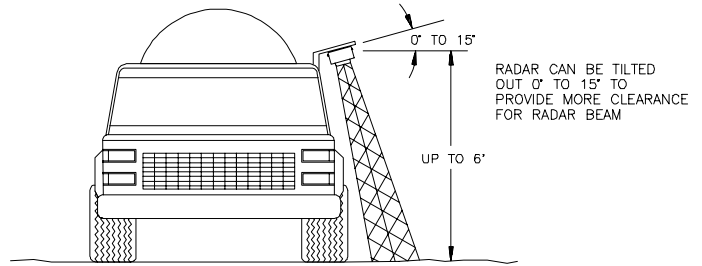
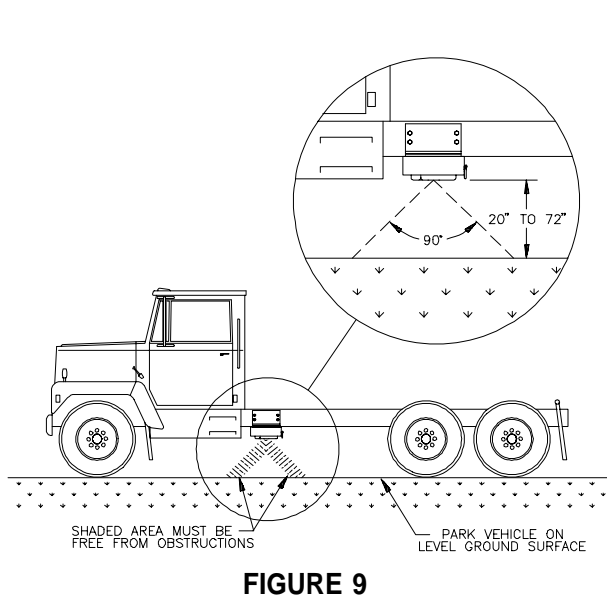

APPENDIX 10

DLA 336 DATA MENU REFERENCE GUIDE

DATA MENU

The DLA 336 has multiple features that are located in the DATA MENU key. The following are brief descriptions of features available under the DATA MENU and the default settings for these features:

DISPLAY SCREENS			
<u>LIQ</u>	<u>DATA</u>	<u>FEATURE</u>	
SERIAL PORT SCREENS			
SPr	Prn	CAL/bEGn/End	CONSOLE DATA PRINTOUT
		0	TRUCK NUMBER
SPr	bAUd	1200	BAUD RATE
SPr	rAtE	on	RATE CHANGE ALARM
SPr	triG	0	DATA LOGGER TRIGGER VALUE
SPr	Unit	Ft	DATA LOGGER TRIGGER UNITS
SPr	dLoG	oFF	DATA LOGGER
GLOBAL POSITIONING SYSTEM SCREENS			
GPS	SYSt	inAC	GPS SYSTEM OPTIONS
ALARM SCREENS			
ALr	ALrM	on	AUDIBLE ALARMS
ALr	Lior	30	LIQUID OFF RATE ALARM
MISCELLANEOUS SCREENS			
MiSC	diSP	on	DISPLAY SMOOTHING
MiSC	Man	oFF	MANUAL CONTROL
MiSC	LEuL	oFF	LOW TANK LEVEL SHUT-OFF
MiSC	AUto	oFF	ZERO SPEED SHUT-OFF
OFFSET SCREENS			
oFS	Anhi	254	ANTI-ICE HIGH OFFSET
oFS	AnLo	2	ANTI-ICE LOW OFFSET

DISPLAY SCREENS

<u>LIQ</u>	<u>DATA</u>		<u>FEATURE</u>
CAL SCREENS			
CAL	SPeD	oFF	SPEED CALIBRATION
CAL	LSPd	0.00	TWO SPEED CAL (Low Gear Ratio)
CAL	hSPd	0.00	TWO SPEED CAL (High Gear Ratio)
CAL	FrEq	180	COIL FREQUENCY
LANE SCREENS			
LAnE	LAnE	12	LANE WIDTH
LAnE	LEfT	144	LEFT LANE WIDTH
LAnE	Cntr	144	CENTER LANE WIDTH
LAnE	rGht	144	RIGHT LANE WIDTH
BLAST SCREENS			
bLAn	ddAY	0.00	DAY DISTANCE
bLAn	dtoL	0	TOTAL DISTANCE
bLAn	udAY	0	DAY VOLUME
bLAn	utoL	0	TOTAL VOLUME

RAVEN

RAVEN INDUSTRIES

Limited Warranty

What Does this Warranty Cover?

This warranty covers all defects in workmanship or materials in your Raven Applied Technology Product under normal use, maintenance, and service.

How Long is the Coverage Period?

Raven Applied Technology Products are covered by this warranty for 12 months after the date of purchase. This warranty coverage applies only to the original owner and is nontransferable.

How Can I Get Service?

Bring the defective part and proof of purchase to your Raven Dealer. If your Dealer agrees with the warranty claim, the Dealer will send the part and proof of purchase to their distributor or to Raven Industries for final approval.

What Will Raven Industries Do?

Upon confirmation of the warranty claim, Raven Industries will, at our discretion, repair or replace the defective part and pay for return freight.

What is not Covered by this Warranty?

Raven Industries will not assume any expense or liability for repairs made outside our facilities without written consent. Raven Industries is not responsible for damage to any associated equipment or products and will not be liable for loss of profit or other special damages. The obligation of this warranty is in lieu of all other warranties, expressed or implied, and no person or organization is authorized to assume any liability for Raven Industries.

Damages caused by normal wear and tear, misuse, abuse, neglect, accident, or improper installation and maintenance are not covered by this warranty.