

2" POLY ON/OFF BALL VALVE REPLACEMENT PARTS

063-0172-186

ITEM	DESCRIPTION	RAVEN PART #
1	Motor Assembly, On/Off Valve	063-0172-149
2	2" Ball Valve	063-0172-287
3	Bracket	107-0171-407
4	Coupler	107-0171-408
5	Washer, Split Lock, 1/4"	313-1000-016
6	Screw, Socket Head Cap, 1/4-20	311-0068-066
7	Washer, Split Lock, 3/8"	313-1000-023
8	Nut, Hexagon, 3/8-16	312-1001-039
9	Washer, Split Lock	313-1000-017
10	Bolt, Hex 1/4-20	311-0050-201
11	2" Valve/Bracket Assembly	063-0172-160

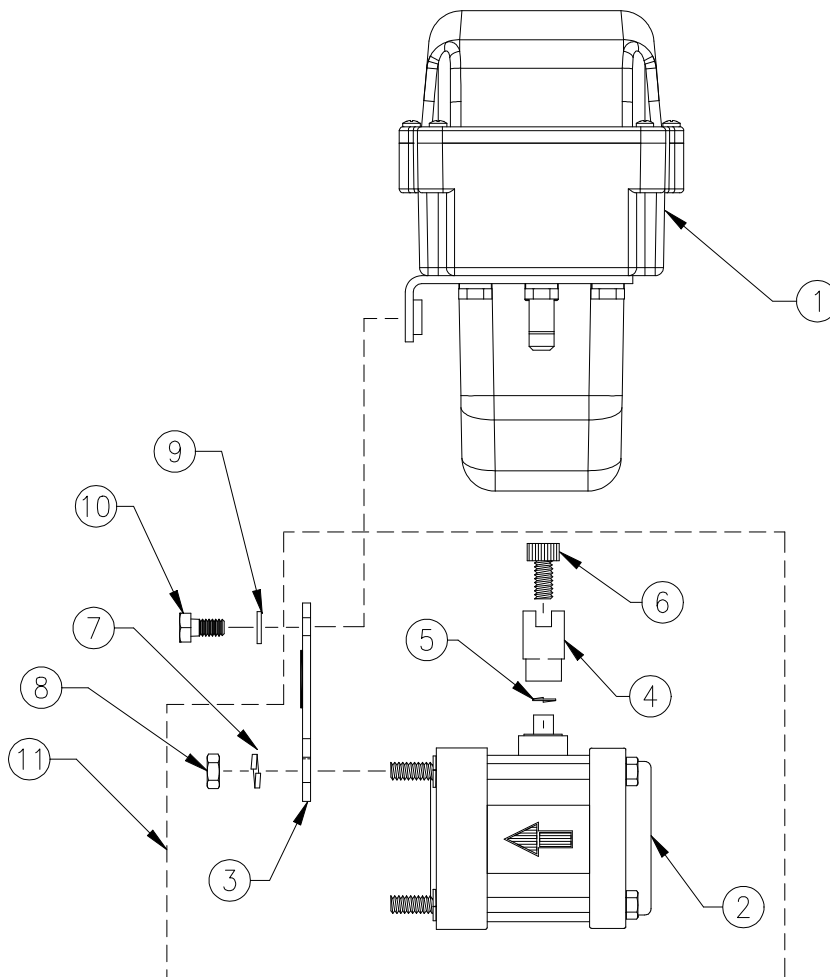

To Assemble:

1. Run motor assembly to fully closed position. Also, make sure ball valve is closed.
2. Assemble bracket to valve using items 7 & 8.
3. Attach coupler to ball valve using items 5 & 6.
4. Assemble Valve/Bracket to motor assembly using items 9 & 10.