

3/4" STAINLESS STEEL BALL VALVE REPLACEMENT PARTS

063-0172-175, Control Valve
063-0172-176, On/Off Valve
063-0172-265, Fast Valve

ITEM	DESCRIPTION	RAVEN PART #
1	Motor Assembly, Control Valve	063-0172-144
	Motor Assembly, On/Off Valve	063-0172-145
	Motor Assembly, Fast Valve	063-0172-146
2	3/4" Ball Valve	334-0001-031
3	Bracket	107-0171-396
4	Washer, Split Lock, #10	313-1000-036
5	Screw, Socket Head Cap, #10-24 x 3/8"	311-0068-047
6	Coupler	107-0171-401
7	Screw, Socket Head Cap, 1/4-20 x 1/2"	311-0068-064
8	Washer, Split Lock, 1/4"	313-1000-017
9	Bolt, Hex, 1/4-20 x 1/2"	311-0050-201
10	Valve/Bracket Assembly	063-0172-154

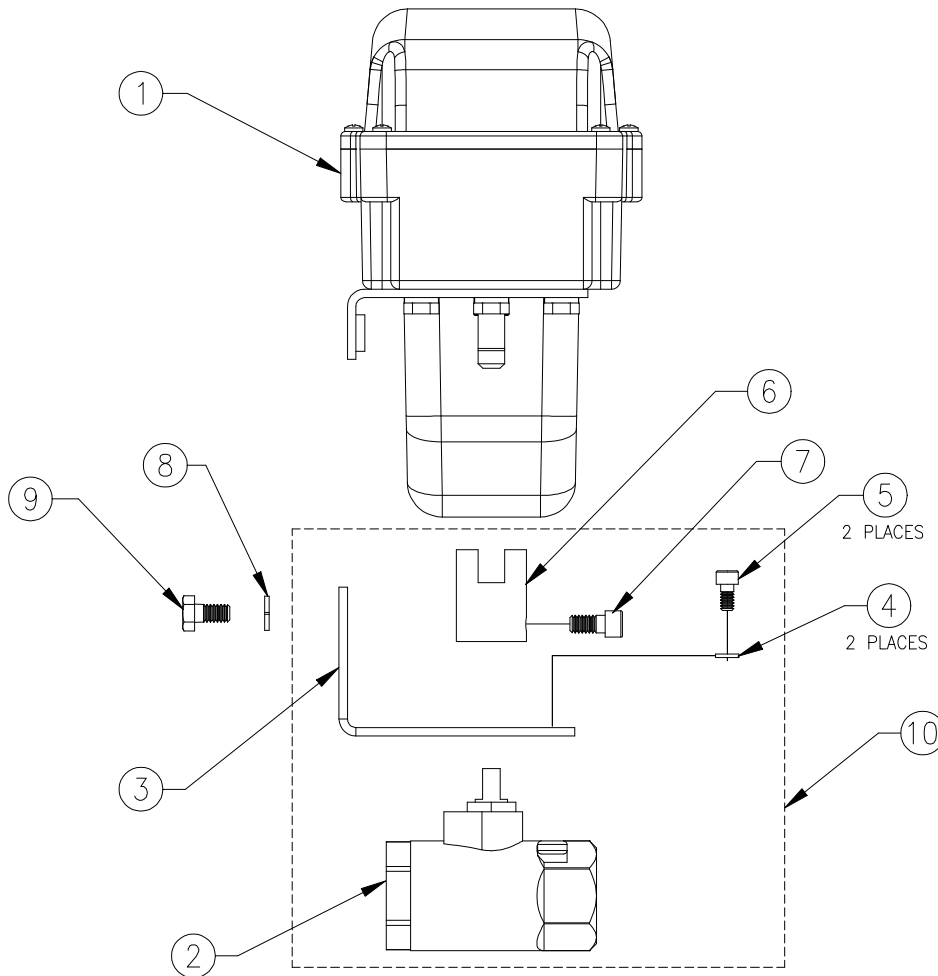

To Assemble:

1. Run motor assembly to fully closed position. Also, make sure ball valve is closed.
2. Assemble bracket to valve.
3. Thread coupler on ball valve the entire way, then back off (no more than 1 turn) until coupler is in position shown above. Tighten cap screw (item 7).
4. Assemble Valve/Bracket to motor assembly using items 8 & 9.