

1" VALVE REPLACEMENT PARTS

063-0172-133

ITEM	DESCRIPTION	RAVEN PART #
1	Valve Cover	106-0159-407
2	Motor Assembly	063-0159-596
3	Woodruff Key	321-0000-062
4	Coupler Shaft Assembly (1" Valve)	019-0159-016
5	Seal Tetraseal	219-0000-020
6	Loctite RC-609 (Not Furnished)	222-1001-050
7	Valve Body Assembly (1" Valve)	063-0172-140
8	Butterfly (1" Valve)	106-0159-411
9	Isolation Flange Assembly	063-0159-457
10	*Iso-Body Kit (1" Valve) (Not Shown)	117-0159-817
11	#6-32 x 3/4" Lg. Screw	321-0000-256

***NOT SUPPLIED WITH STANDARD UNIT**

NOTE: Iso-Body kit includes items 3 thru 5, 7 thru 9 and 11.

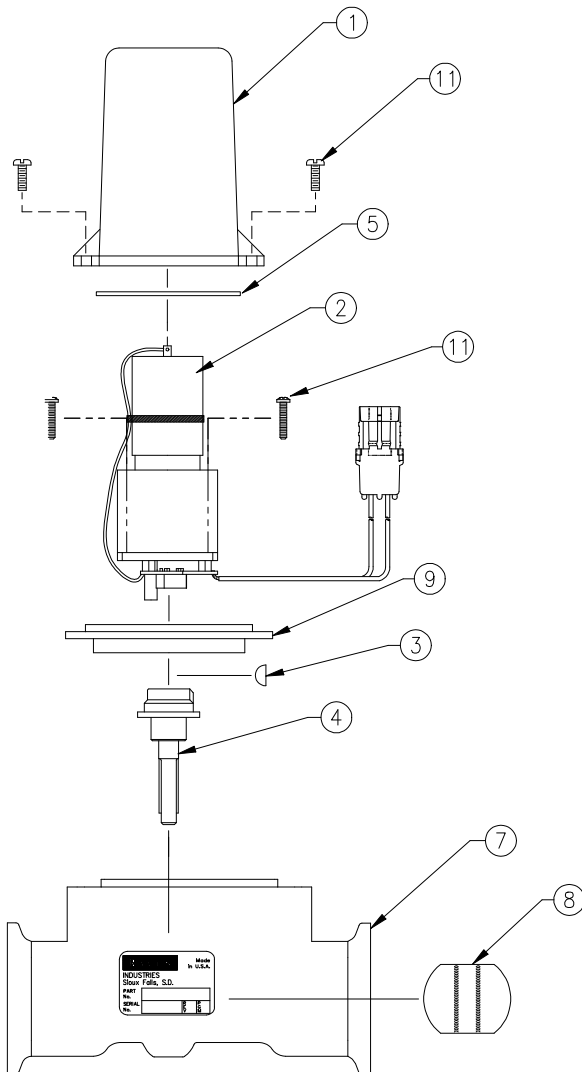

When servicing Valve:

Replace valve body with iso-body kit (item 10) if valve has been leaking internally.

Replace motor assembly if the motor will not run or if the printed circuit board is corroded.

Before reassembling valve, remove the coupler shaft from the valve body. Apply Loctite (item 6) to coupler shaft and woodruff key. Place the coupler shaft (item 4) and the woodruff key (item 3) onto the motor shaft. Plug motor into the valve connector coming from Sprayer Control Console. Check that the motor rotates in both directions. Motor must stop when coupler shaft CAM releases printed circuit board switch button.

When reassembling valve, grease both sealing surfaces of coupler shaft. Insert coupler shaft into iso-flange and be sure seal properly seats on shaft. Install motor on valve body and apply silicon sealant to mounting holes. Reassemble remaining items as shown in parts diagram.

RAVEN INDUSTRIES, INC.