

AUTOBOOM

Installation Manual



Spray Air 2010 Predator

CHAPTER

1

INTRODUCTION

Congratulations on your purchase of the Raven Autoboom system! This system is designed to provide worry-free operation of your hydraulically controlled booms. The following instructions are designed to assist you in the proper installation of the system hardware. The Autoboom hydraulic installation process is fairly straight forward and prior knowledge of the machine's hydraulic system is beneficial. Be sure to carefully follow the safety and installation instructions of this manual. Be sure to pay careful attention to the hydraulics installation. Improper installation could result in a system that does not work correctly. Following the completion of the hardware installation, refer to the instructions in the Power Glide, Power Glide Plus and Ultra Glide Calibration and Operator's manual.



This manual gives the installation instructions for the Power Glide, Power Glide Plus, and Ultra Glide Systems. Be sure to identify which system you have and follow only the instructions for that system.

Basic Kit Contents

PowerGlide System

- ◆ **Hardware Installation Kit 117-0230-064**
 - ◆ Hydraulic Hose and Fitting Kit
 - ◆ Hydraulic Valve and Mounting Hardware
 - ◆ Axle Mounting Brackets and Mounting
- ◆ **Axle Kit 117-0131-**
 - ◆ 2 Axles
- ◆ **Controller Kit 117-0137-022**
 - ◆ In-Cab Controller
 - ◆ Main Harness Cable
 - ◆ Power Cable (Controller to Switched Power Source)

PowerGlide Plus System

- ◆ **Hardware Installation Kit 117-0231-064**
 - ◆ Wheel Kit
 - ◆ Hydraulic Hose and Fitting Kit.
 - ◆ Hydraulic Valve and Mounting Hardware
- ◆ **Controller Kit 117-0137-023**
 - ◆ Main Harness Cable
 - ◆ Power Cable (Controller to Switched Power Source)
 - ◆ CAN Node

UltraGlide System

- ◆ **Hardware Installation Kit 117-0232-064**
 - ◆ Ultrasonic Sensors
 - ◆ Hydraulic Hose and Fitting Kit.
 - ◆ Hydraulic Valve and Mounting Hardware
- ◆ **Controller Kit 117-0137-023**
 - ◆ Main Cable
 - ◆ Power Cable (Controller to Switched Power Source)
 - ◆ CAN Node

Installation Manual Machine Reference

Make: Spray Air
Model: 2010
Year:
Serial Number:

CHAPTER

2

SAFETY

Installation Safety Requirements

This section is divided between general safety precautions, specific safety measures in respect to the hydraulic and electrical system, and machine driving and operating safety.



Important: The machine must remain stationary and switched off, the booms unfolded and supported, while installation or maintenance is conducted.

Safety Precautions

When working with or near a machine with Autoboom installed, the following safety measures must be observed. The operator *must*:

- ◆ Be alert and aware of surroundings.
- ◆ Not operate Autoboom or any agricultural equipment while under the influence alcohol or an illegal substance.
- ◆ Remain in the operator's position in the machine at all times when Autoboom is engaged.
- ◆ Disable Autoboom when exiting from the operator's seat and machine.
- ◆ Not drive the machine with Autoboom enabled on any public thoroughfare or main road.
- ◆ Determine and remain a safe working distance from other individuals. The operator is responsible for disabling Autoboom when the safe working distance has diminished.
- ◆ Ensure Autoboom is disabled prior to starting any maintenance work on Autoboom or machine.

Hydraulic Safety Precautions



Important: Sprayer hydraulics are under pressure. Never attempt to open or work on a hydraulic system with the equipment running. Care should always be taken when first opening a system that was previously pressurized.

When disconnecting the hydraulic hoses or when purging is required, be aware that the hydraulic oil within the machine system may be extremely hot and under high pressure. Caution must be exercised. Any work carried out on the hydraulic system must be performed in accordance with the machine manufacturer's approved maintenance instructions. Raven industries recommends that appropriate protective equipment be worn when working on the hydraulic system.



Important: It is imperative that when installing Autoboom hydraulics, performing diagnostics, maintenance, or routine machine servicing, that all installers and customers ensure precautions are taken to prevent any foreign material or contaminants from being introduced into the machine's hydraulic system.

Objects or materials that are able to bypass the machine's hydraulic filtration system will adversely reduce performance and possibly damage the Autoboom hydraulic valves.

Electrical Safety Precautions

Do not reverse the power leads. Doing so will cause severe damage to the equipment. Always ensure the power leads are connected to the correct polarity as marked. Ensure that the power cable is the last cable to be connected.

Driving Safety Requirements

This section outlines the safety requirements used when driving a vehicle using the Autoboom system.

Areas of Operation

The Autoboom must only be used on private property without public access. It must only be used within cleared fields. It must not be used when traveling on any public roads or access ways. Raven Industries advises that users familiarize themselves with Autoboom operation by first reading the Autoboom Installation Manual and the PowerGlide, PowerGlide Plus, or UltraGlide Calibration and Operator's Manual.

Avoidance of People

Autoboom must not be operated in the vicinity of people. Bystanders must be well outside of the machine's path while Autoboom is enabled.

Avoidance of Machinery and Equipment

The Autoboom operator must allow a safe distance between the machine's path and other machinery or equipment. To determine a safe distance, take into account the incorrect operation of the boom management system and the width of the booms.

Avoidance of Obstacles

Autoboom CANNOT detect obstacles such as fences, trees, or boulders that are not located within the sensor or wheel path. The machine operator must identify and avoid obstacles that are not able to be detected by the boom sensors or wheels while working in a field.

Responsibilities of Operator

The operator must remain in complete control of the machine at all times. Only when Autoboom is enabled can there be hands-free operation of the booms. The operator remains fully responsible for the operation of the machine and must remain in the operator's seat at all times while Autoboom is enabled.

Disengaging Boom Control

The operator must naturally lift the booms if an obstacle is in the line of travel and is not detected by the sensor or wheels. Pressing the "Up" function on the boom controller will disengage Autoboom if Boom Sense wires have been installed.

Contacting Raven Industries

We welcome your feedback about this manual. If you have any comments or suggestions for improvement, please let us know by contacting our Customer Support Center by any of the following methods:

- ◆ **Via phone:** 1-800-243-5435

- ◆ **Via mail:**
Raven Industries
Flow Control Division
205 E. 6th St.
Sioux Falls, SD 57104

- ◆ **Via email:** fcinfo@ravenind.com

POWER GLIDE

CHAPTER

3

POPULATING AND MOUNTING THE VALVE

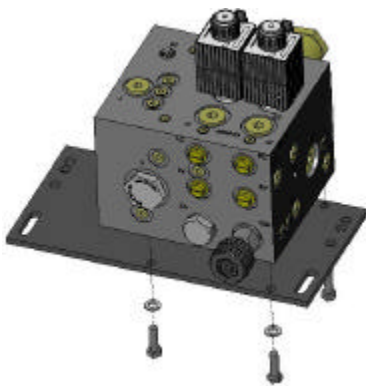

Autoboomb Valve

FITTING	PORT
3/4" JIC (M) to 3/4" SAE O-Ring (M)	P (Filter), T
9/16" JIC (M) to 9/16" SAE O-Ring (M)	LV, RV, LC, RC
9/16" JIC (M) to 7/16" SAE O-Ring (M)	LS2

Priority Valve

FITTING	PORT
9/16" JIC (M) to 7/16" SAE O-Ring (M)	T, LS
3/4" JIC (M) to 3/4" SAE O-Ring (M)	P, EF
9/16" JIC (M) to 9/16" SAE O-Ring (M)	CF

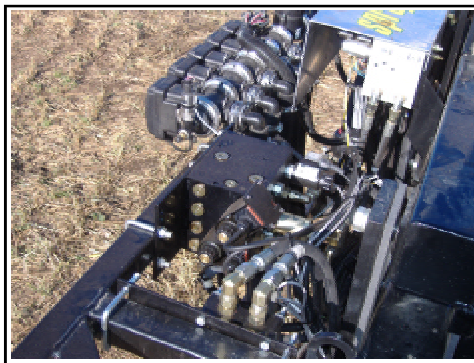

Mount Autoboomb valve on center rack.

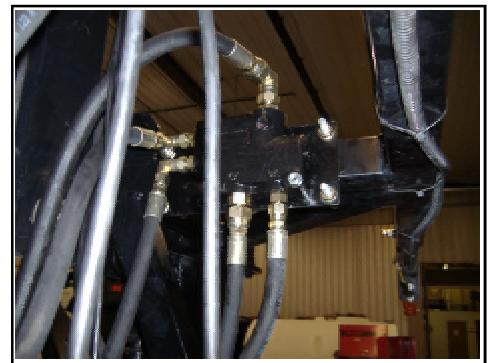

Mount Priority valve on center rack to the right of the Autoboomb valve.

Power Glide Dual Cartridge Option

1. Remove cavity plug (5A) and port plug (6A).
2. Discard port plug (6A) or keep for future upgrade to Power Glide Plus.

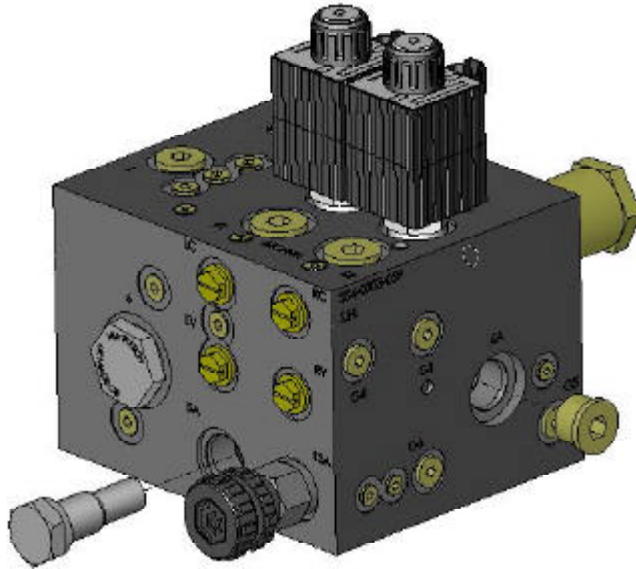

3. Insert cavity plug from port 5A into port 6A.
4. Install mechanical cartridge into port 5A.

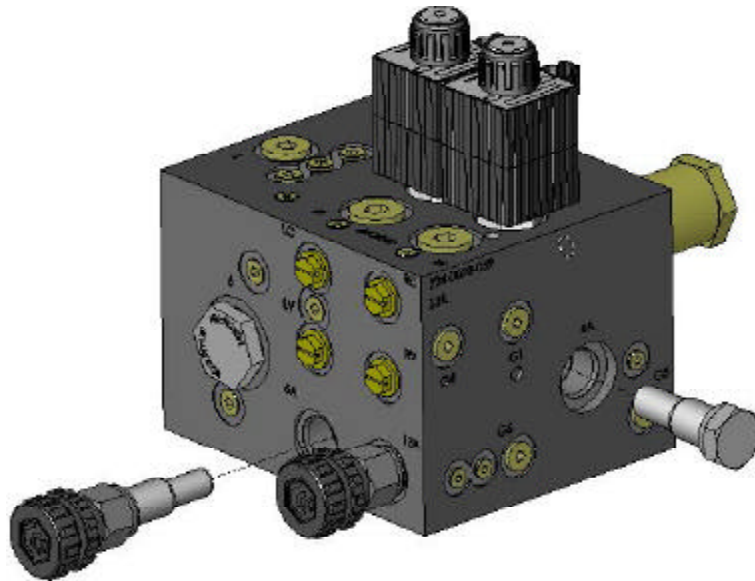

CHAPTER

4

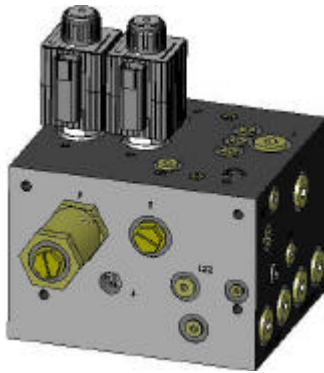
HYDRAULIC HOSE & FITTINGS INSTALLATION**ORIENTATION**

P/N	MACHINE		AUTOBOOM VALVE	
	HOSE END	LOCATION	HOSE END	LOCATION
214-1000-112	3/4" JIC (F)	Pressure Port	3/4" JIC (F)	EF (Priority Valve)
214-1000-331	3/4" JIC (F)	Tank Tee	3/4" JIC (F)	Tank Tee
214-1000-197	9/16" JIC (F)	Left Up	9/16" JIC (F)	LV
214-1000-197	9/16" JIC (F)	Right Up	9/16" JIC (F)	RV
214-1000-197	9/16" JIC (F)	LS (Priority Valve)	9/16" JIC (F)	LS2
214-1000-197	9/16" JIC (F)	T (Priority Valve)	9/16" JIC (F)	Tank Tee
214-1000-459	9/16" JIC (F)	CF (Priority Valve)	3/4" JIC (F)	P (Filter)
214-1000-430	9/16" JIC (F)	Left Tilt Cyl. Hose	9/16" JIC (F)	LC
214-1000-431	3/4" JIC (F)	Pressure Hose	3/4" JIC (F)	P (Priority Valve)

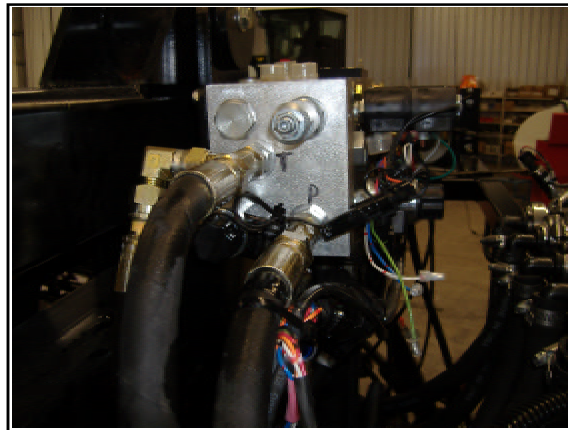
Pressure and Tank Lines

- ◆ Disconnect pressure line from machine manifold. Insert pressure line extension hose and connect to P port on priority valve.
- ◆ Connect EF port on priority valve to pressure port on machine manifold using supplied hose.
- ◆ Connect CF port on priority valve to P (Filter) port on Autoboom block using supplied hose.

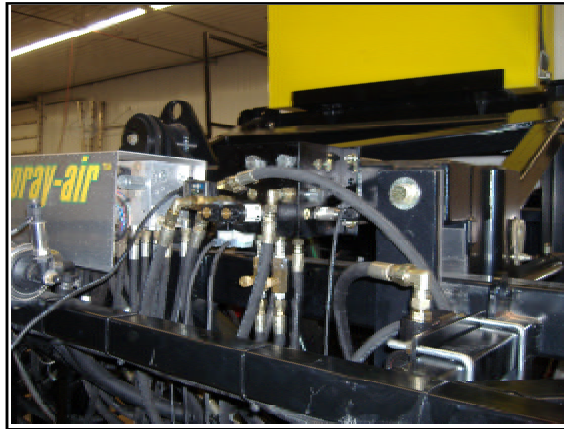

- ◆ Connect priority valve T port, Autoboam valve T port, and machine manifold T port together using supplied hoses and tee fittings.

LC, RC, LV, RV

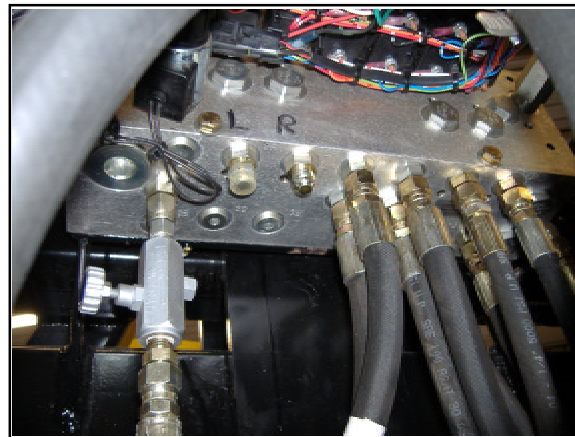
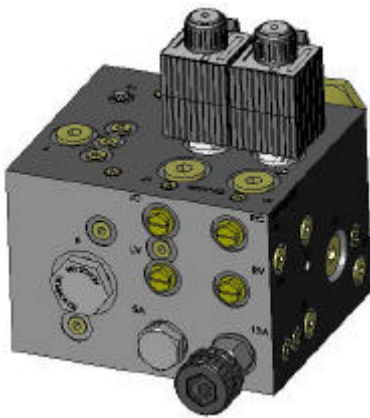

- ◆ Disconnect left and right Up lines from machine manifold and connect to LC (use supplied hose extension) and RC respectively on Autoboam valve.

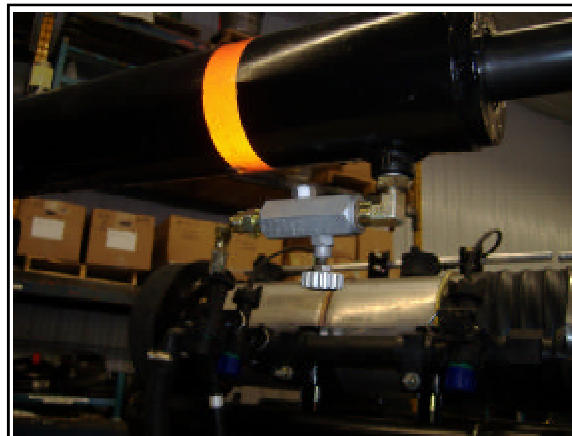

- ◆ Remove restrictor assembly and replace 90° fitting on left and right tilt cylinders.

LC, RC, LV, RV



- ◆ Replace 90° fitting on restrictor assemblies.

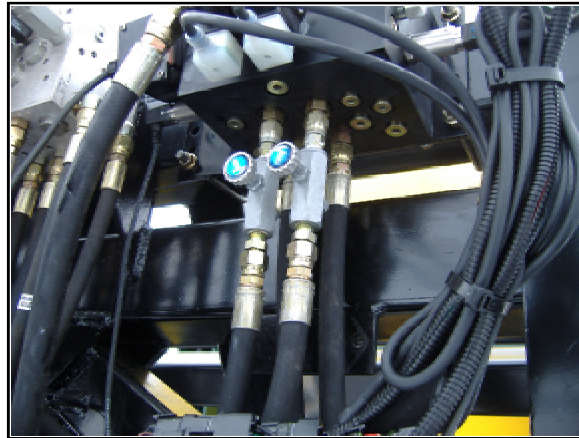

- ◆ Connect restrictor assemblies to LV and RV ports on Autoboom valve.
- ◆ Connect LV and RV ports to left and right 'Up' ports (respectively) on machine manifold using supplied hoses.

Load Sense

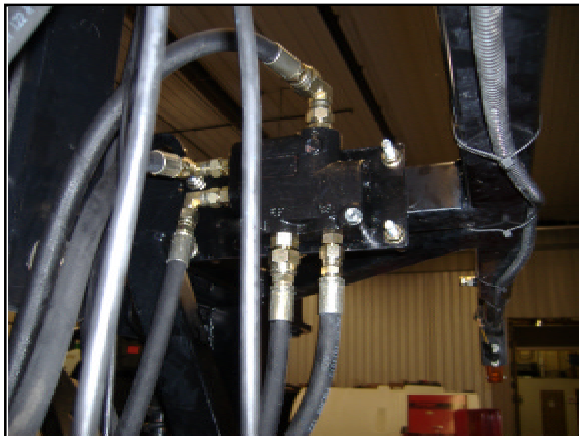
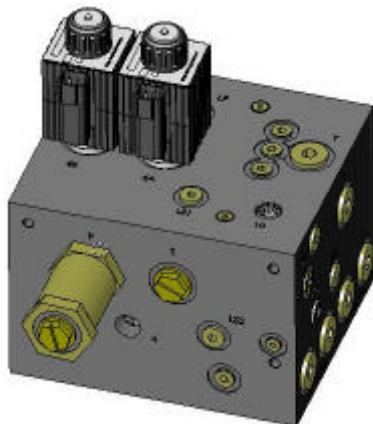

- ◆ Connect LS port on priority valve to LS2 port on Autoboom valve using supplied hose.

Power Glide Hydraulic Schematic

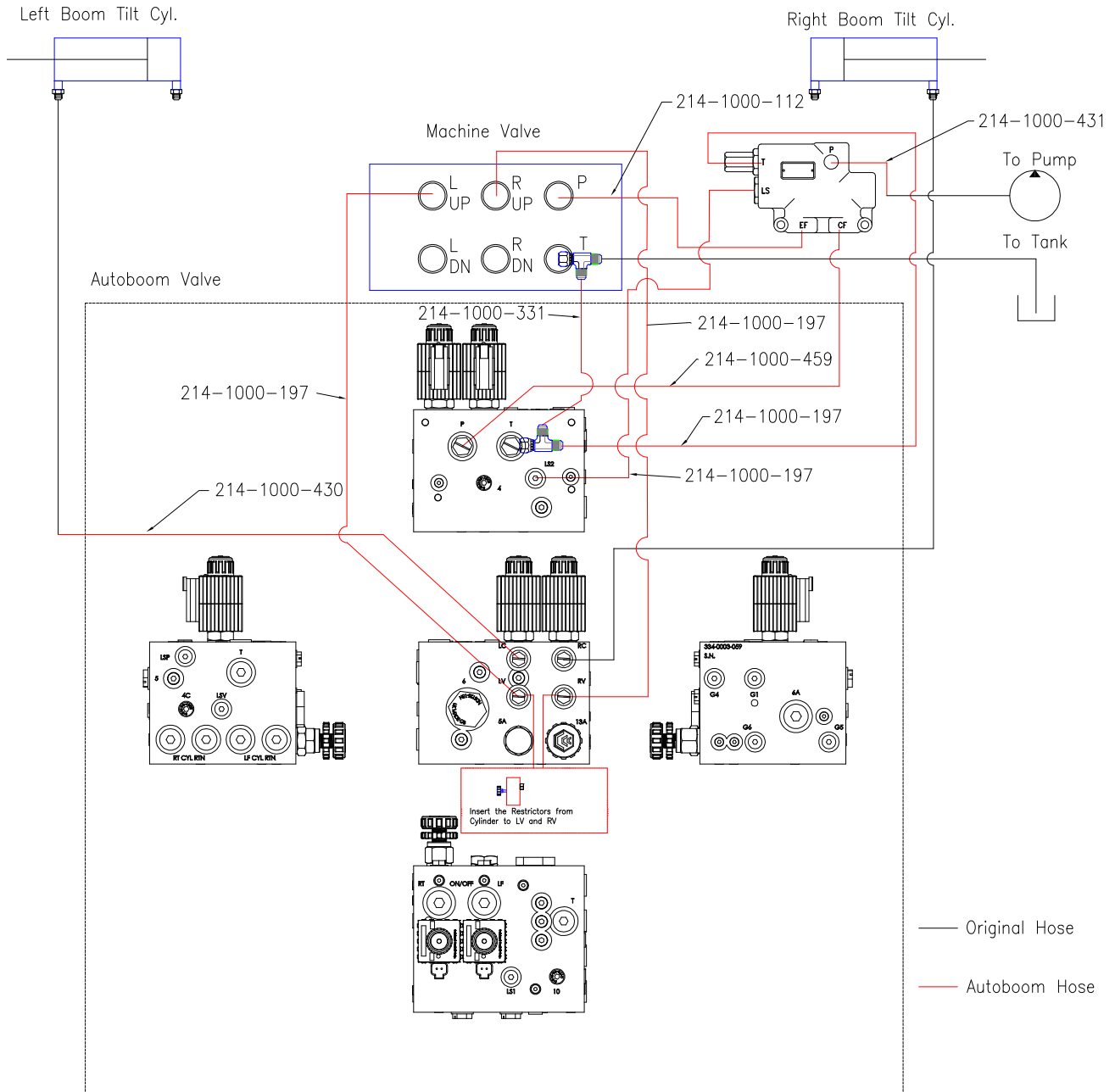

POWER GLIDE PLUS & ULTRA GLIDE

CHAPTER

5

POPULATING AND MOUNTING THE VALVE

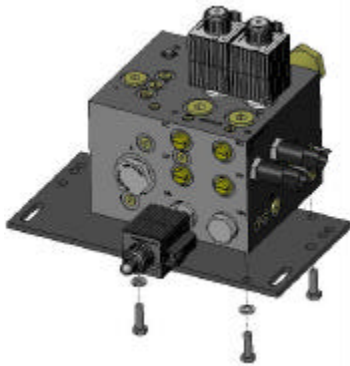

Autoboomb Valve

FITTING	PORT
3/4" JIC (M) to 3/4" SAE O-Ring (M)	P (Filter), T
9/16" JIC (M) to 9/16" SAE O-Ring (M)	LV, RV, LC, RC
9/16" JIC (M) to 7/16" SAE O-Ring (M)	LS2

Priority Valve

FITTING	PORT
9/16" JIC (M) to 7/16" SAE O-Ring (M)	T, LS
3/4" JIC (M) to 3/4" SAE O-Ring (M)	P, EF
9/16" JIC (M) to 9/16" SAE O-Ring (M)	CF



NOTE: Ultra Glide - Make sure floating orifice in **LC** and **RC** ports are installed with slot facing out.

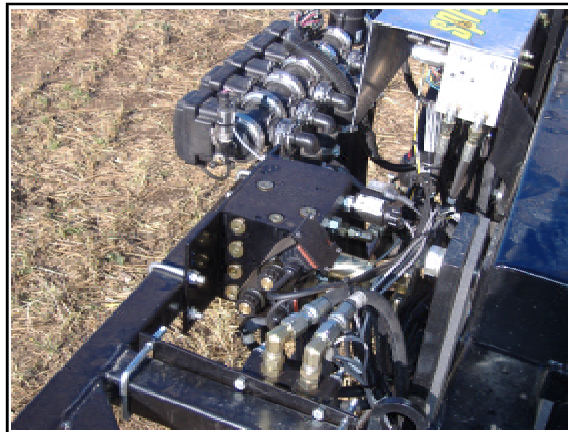
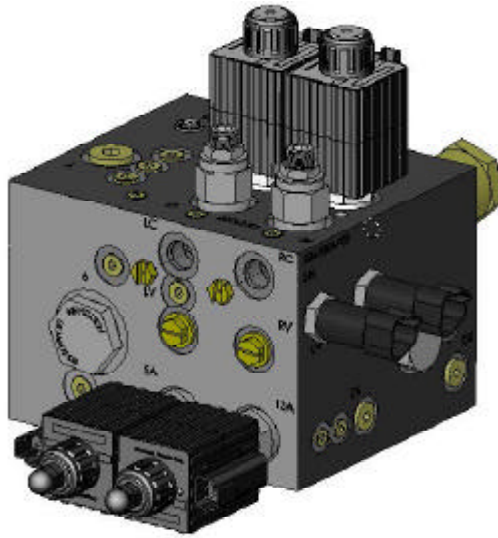

Mount Autoboom valve on center rack.

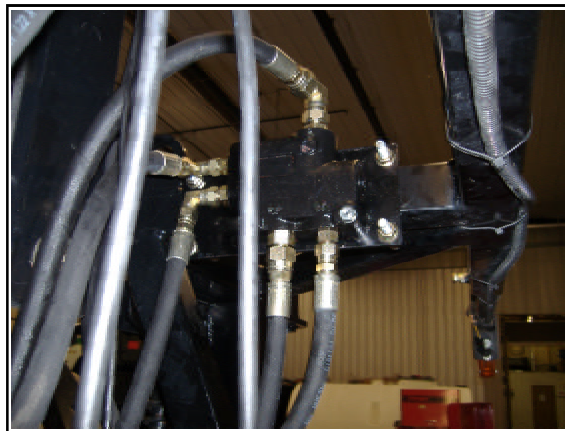

Mount priority valve on center rack to the right of the Autoboom valve.

CHAPTER

6

HYDRAULIC HOSE & FITTING INSTALLATION

ORIENTATION

P/N	MACHINE		AUTOBOOM VALVE	
	HOSE END	LOCATION	HOSE END	LOCATION
214-1000-112	3/4" JIC (F)	Pressure Port	3/4" JIC (F)	EF (Priority Valve)
214-1000-331	3/4" JIC (F)	Tank Tee	3/4" JIC (F)	Tank Tee
214-1000-197	9/16" JIC (F)	Left Up	9/16" JIC (F)	LV
214-1000-197	9/16" JIC (F)	Right Up	9/16" JIC (F)	RV
214-1000-197	9/16" JIC (F)	LS (Priority Valve)	9/16" JIC (F)	LS2
214-1000-197	9/16" JIC (F)	T (Priority Valve)	9/16" JIC (F)	Tank Tee
214-1000-459	9/16" JIC (F)	CF (Priority Valve)	3/4" JIC (F)	P (Filter)
214-1000-430	9/16" JIC (F)	Left Tilt Cyl. Hose	9/16" JIC (F)	LC
214-1000-431	3/4" JIC (F)	Pressure Hose	3/4" JIC (F)	P (Priority Valve)

Pressure and Tank Lines

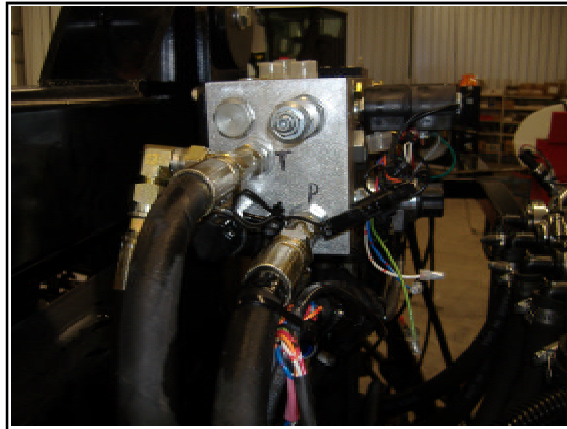

- ◆ Disconnect pressure line from machine manifold. Insert pressure line extension hose and connect to P port on priority valve.
- ◆ Connect EF port on priority valve to pressure port on machine manifold using supplied hose.
- ◆ Connect CF port on priority valve to P (Filter) port on Autoboom block using supplied hose.

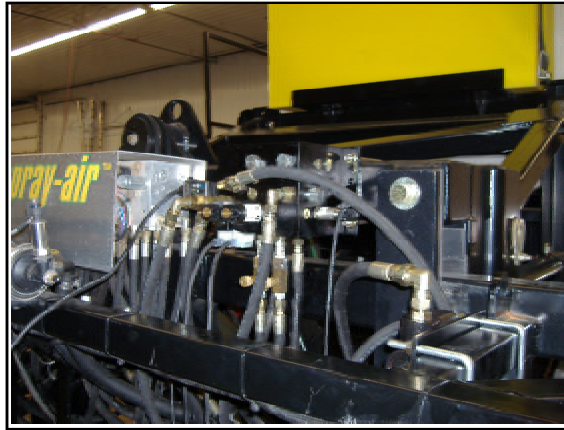

- ◆ Connect priority valve T port, Autoboam valve T port, and machine manifold T port together using supplied hoses and tee fittings.

LC, RC, LV, RV

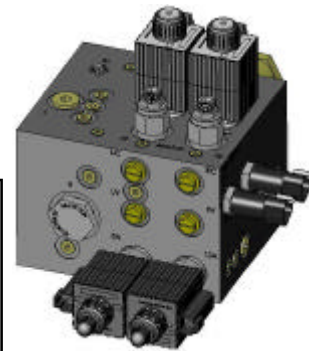
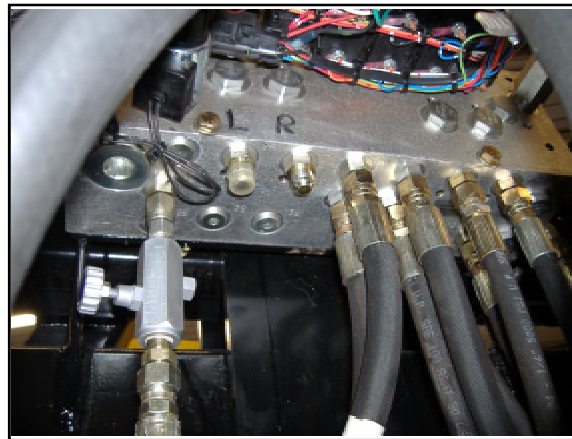

- ◆ Disconnect left and right Up lines from machine manifold and connect to LC (use supplied hose extension) and RC respectively on Autoboam valve.

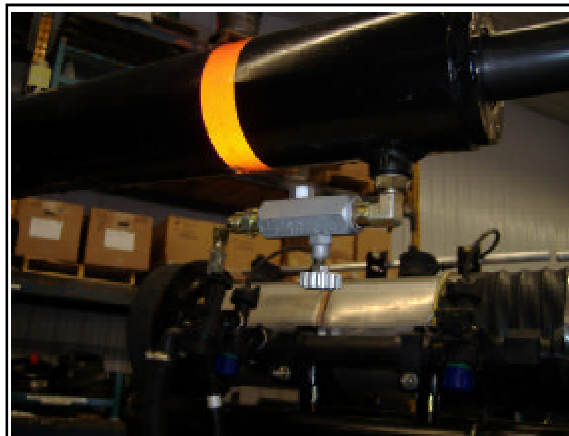

- ◆ Remove restrictor assembly and replace 90° fitting on left and right tilt cylinders.



- ◆ Replace 90° fitting on restrictor assemblies.

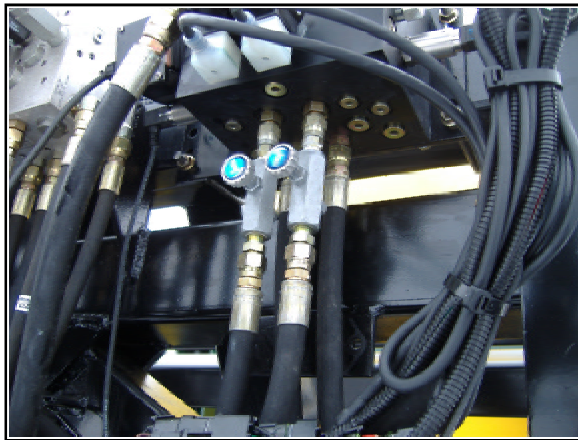

- ◆ Connect restrictor assemblies to LV and RV ports on Autoboom valve.
- ◆ Connect LV and RV ports to left and right 'Up' ports (respectively) on machine manifold using supplied hoses.

Load Sense

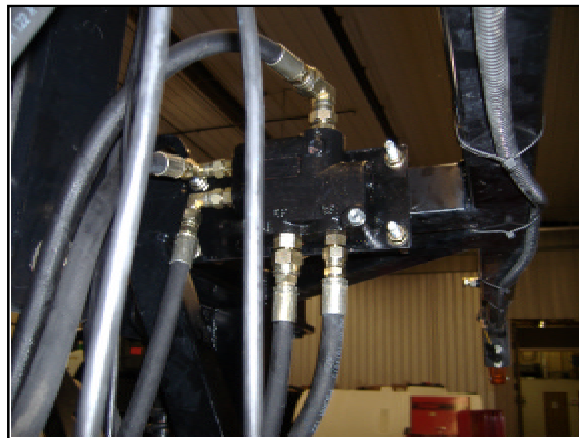
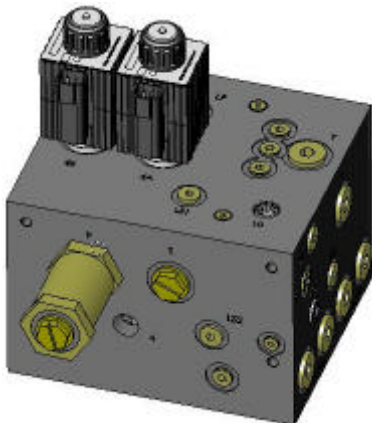

- ◆ Connect LS port on priority valve to LS2 port on Autoboom valve using supplied hose.

Power Glide Plus & Ultra Glide Hydraulic Schematic

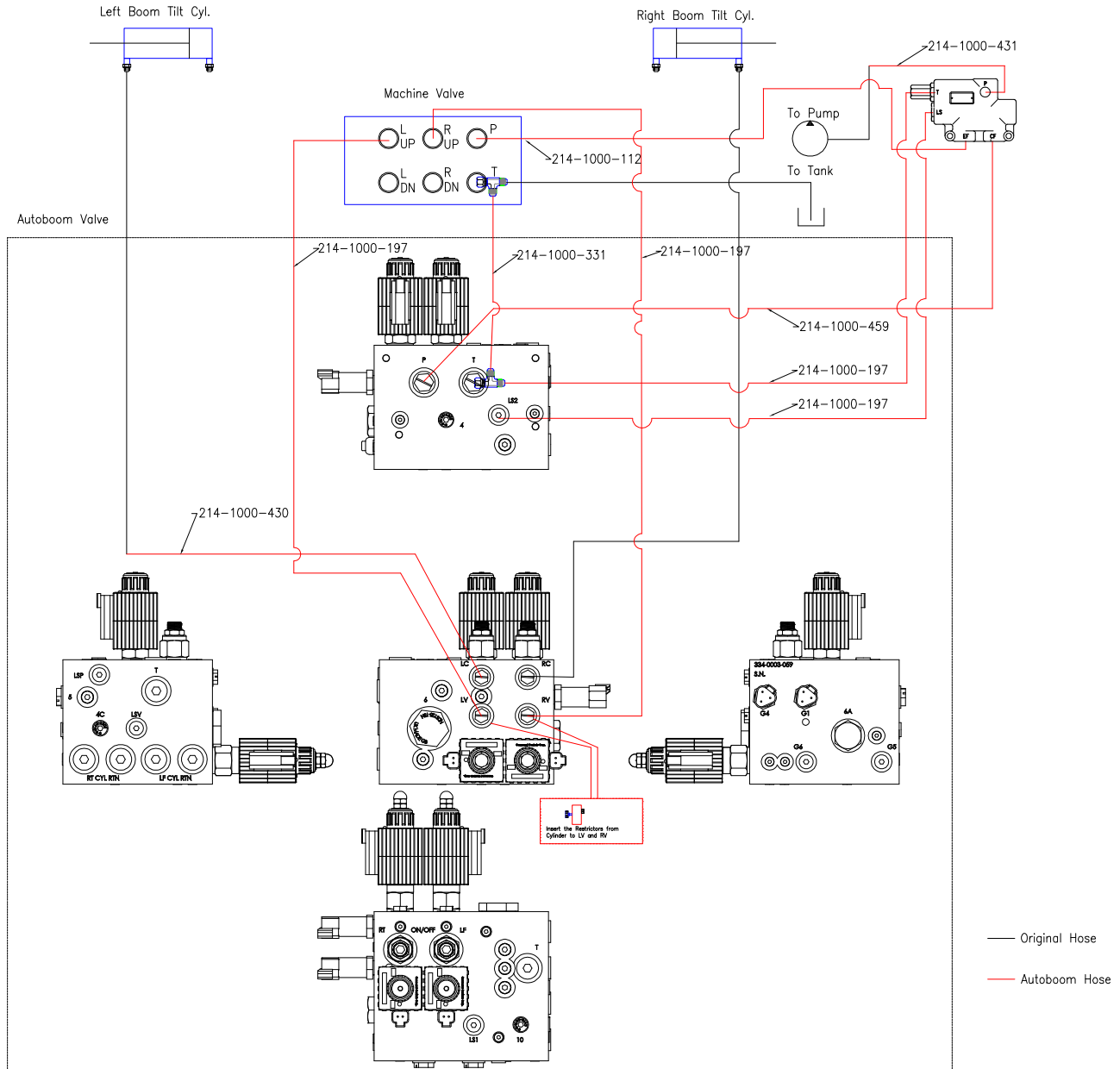

CHAPTER

7

WHEEL & SENSOR MOUNTING

Wheel Mounting



Mount axle receiver bracket just inside first boom fold.



Sensor Mounting



Mount sensor near boom tip.

CHAPTER

8

CONTROLLER & WIRING HARNESS

- ◆ Use the following diagrams to install the wiring harness.
- ◆ Be sure to allow enough slack in harness when racking booms.
- ◆ Connect power leads to battery.

Power Glide

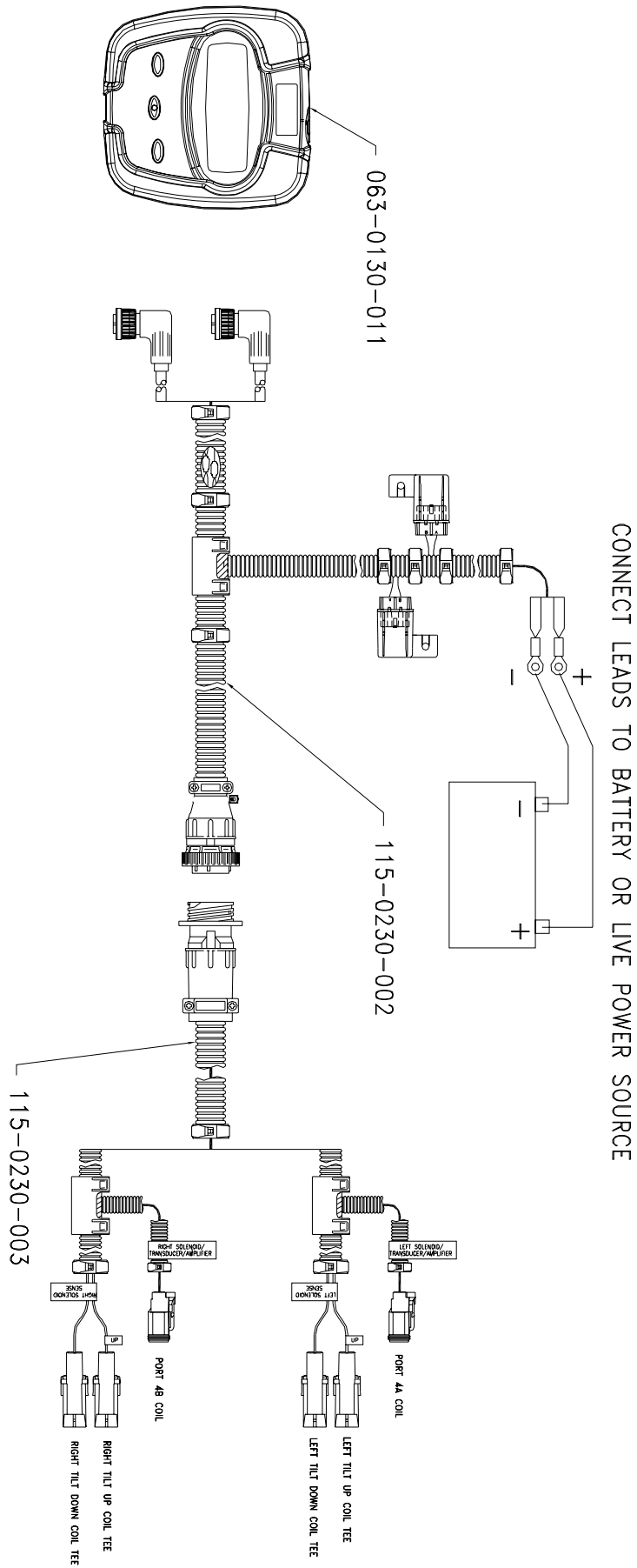

Power Glide Plus

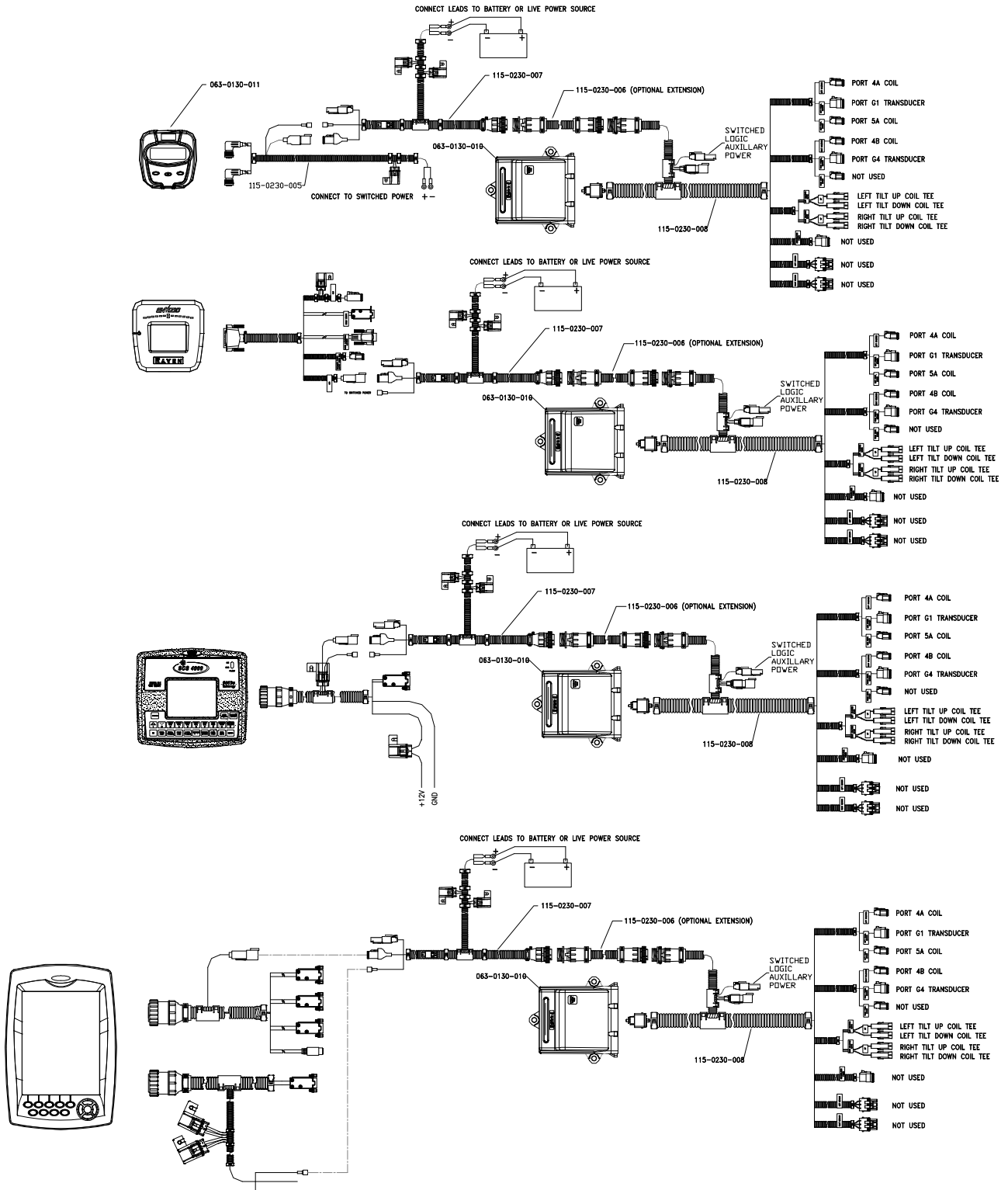

Ultra Glide

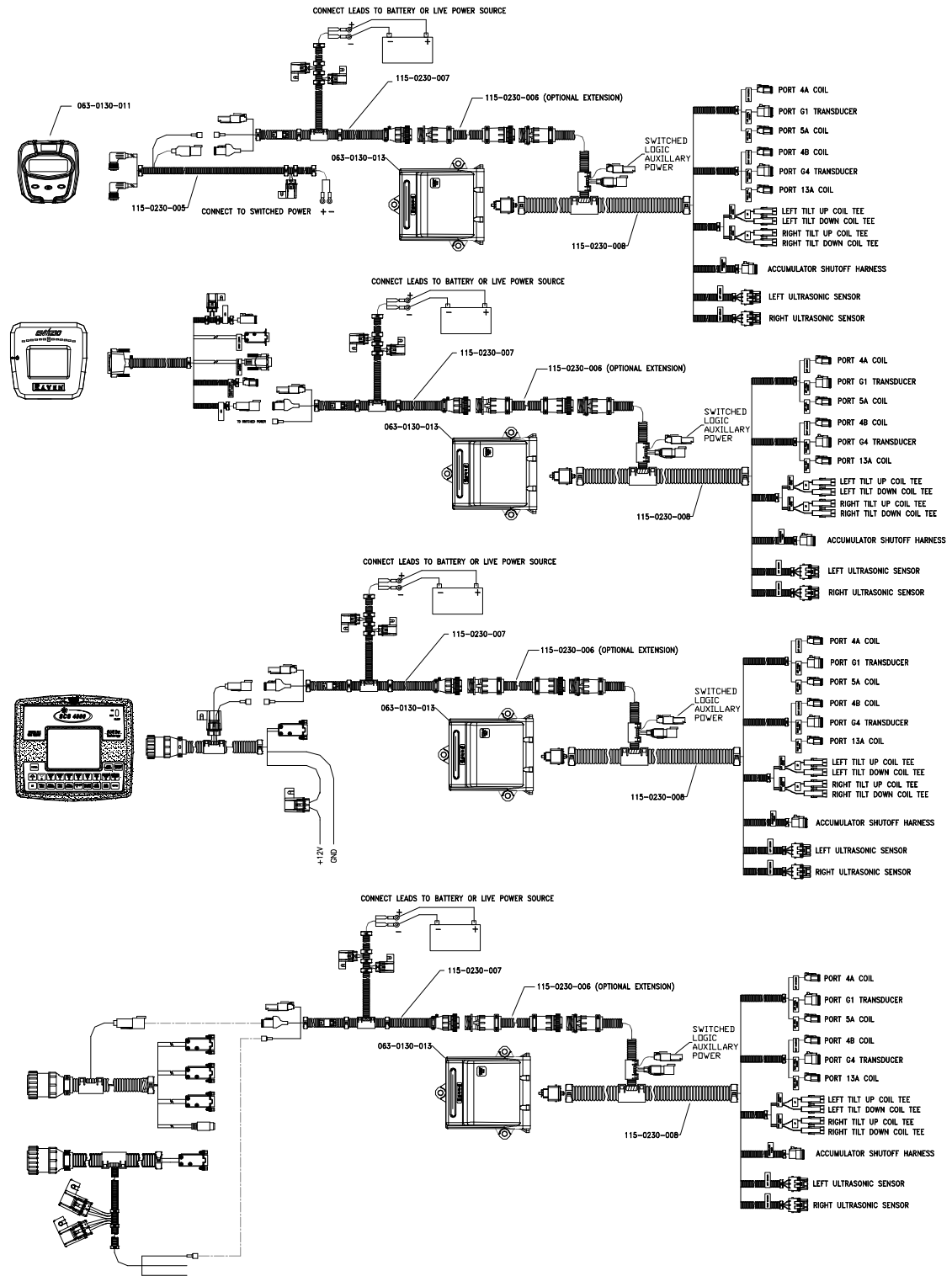

A P P E N D I X



REPLACEMENT PARTS

On the following pages you will find replacement part diagrams and listings for Power Glide, Power Glide Plus, and Ultra Guide systems. Please refer to these diagrams when calling to request replacement parts.

Valve Blocks

Power Glide Valve Block Replacement Parts Drawing

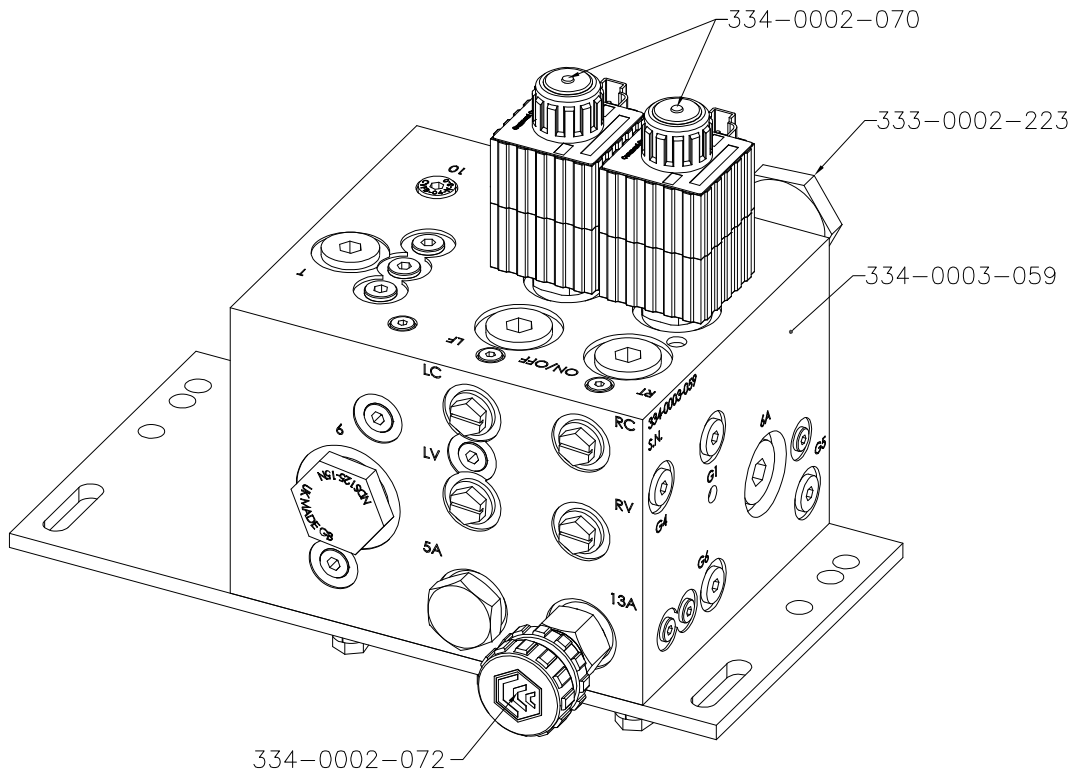

Power Glide Plus Valve Block Replacement Parts Drawing

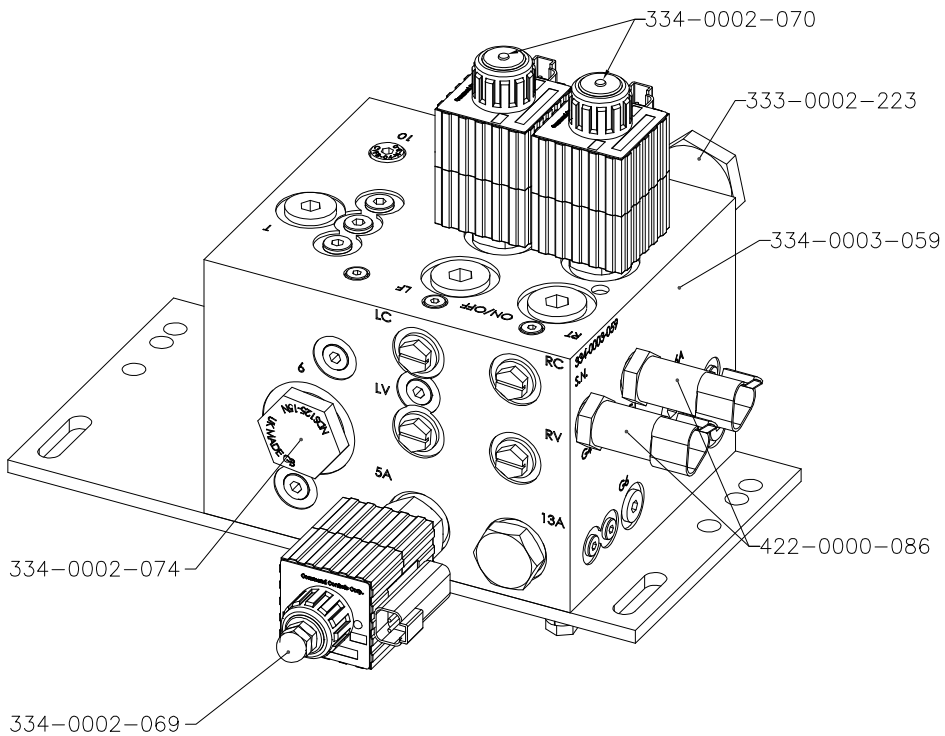

Ultra Glide Valve Block Replacement Parts Drawing

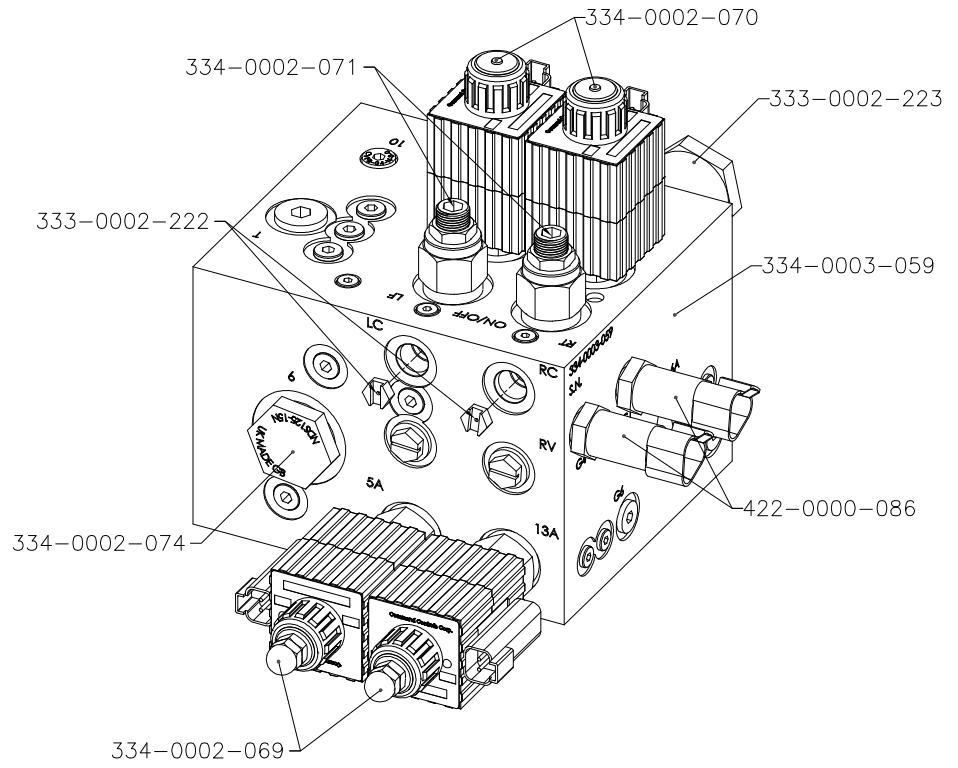

Wheel Assembly and Brackets

Machine Specific Wheel and Bracket Drawing

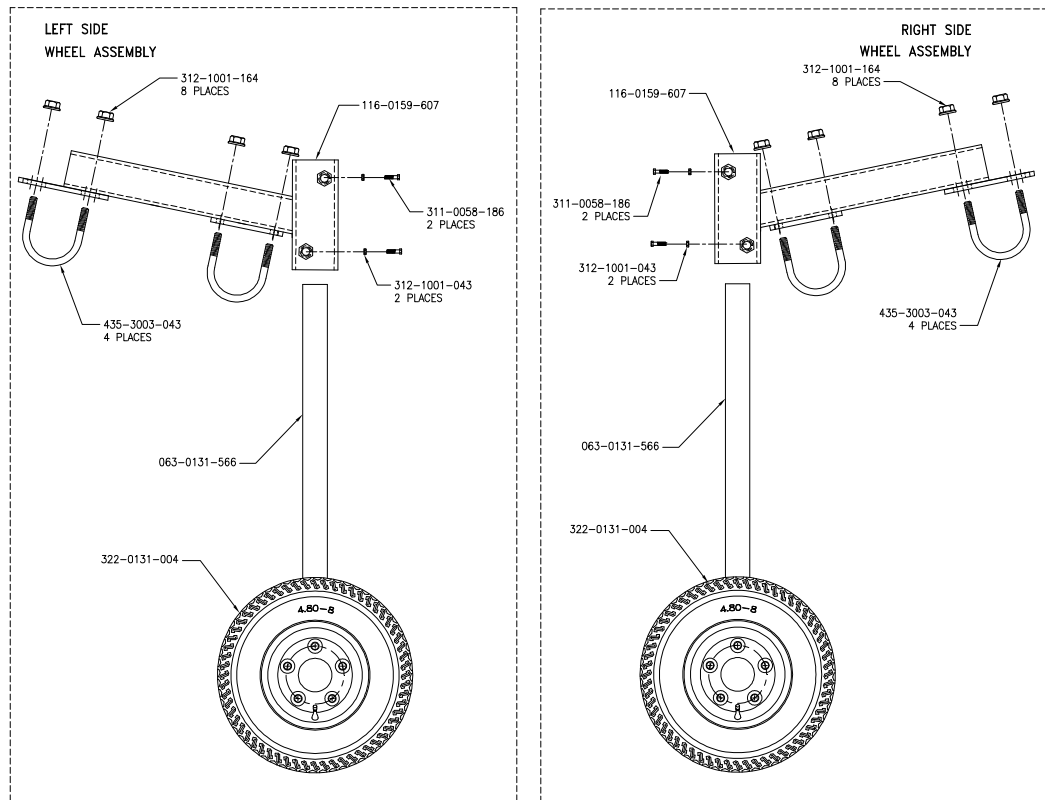

Cushioned Axle Replacement Parts Drawing

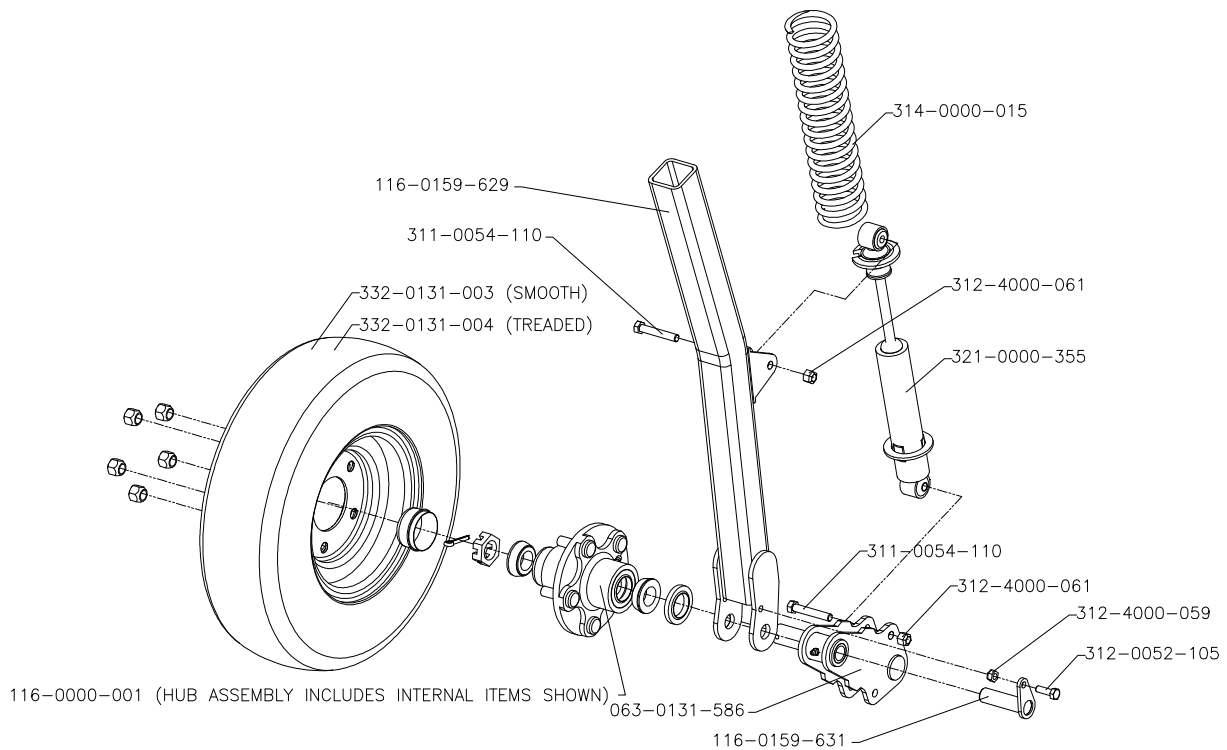

Sensor and Brackets

Machine Specific Sensor U-Bolt Drawing

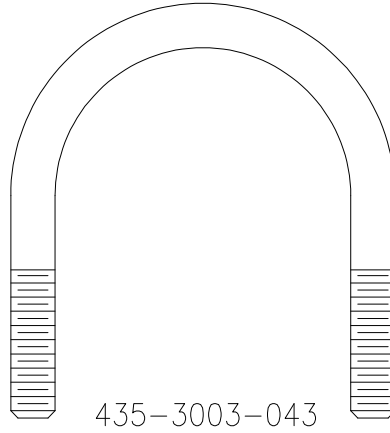

Molded Sensor Replacement Parts Drawing

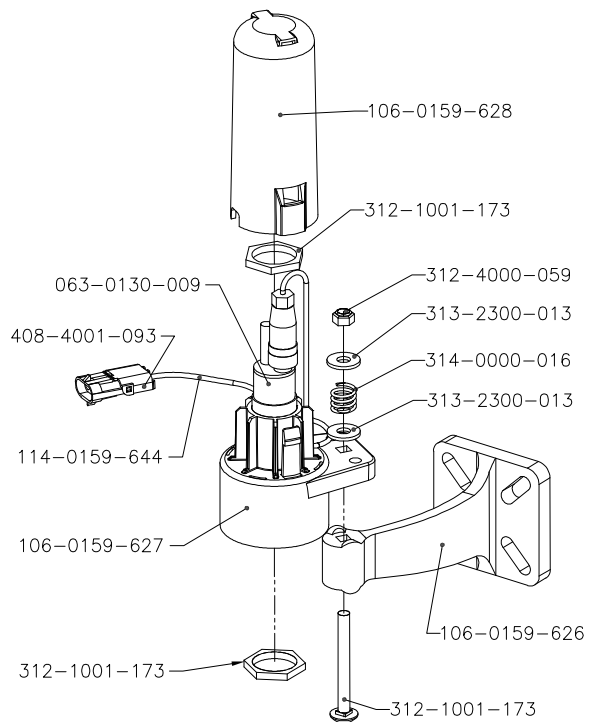

NOTES:



RAVEN INDUSTRIES

LIMITED WARRANTY

WHAT IS COVERED?

This warranty covers all defects in workmanship or materials in your Raven Flow Control Product under normal use, maintenance, and service.

HOW LONG IS THE COVERAGE PERIOD?

This warranty coverage runs for 12 months from the purchase date of your Raven Flow Control Product. This warranty coverage applies only to the original owner and is not transferrable.

HOW CAN YOU GET SERVICE?

Bring the defective part, and proof of date of purchase, to your local dealer. If your dealer agrees with the warranty claim, he will send the part, and proof of purchase to his distributor or to Raven for final approval.

WHAT WILL RAVEN INDUSTRIES DO?

When our inspection proves the warranty claim, we will, at our option, repair or replace the defective part and pay for return freight.

WHAT DOES THIS WARRANTY NOT COVER?

Raven Industries will not assume any expense or liability for repairs made outside our plant without written consent. We are not responsible for damage to any associated equipment or product and will not be liable for loss of profit or other special damages. The obligation of this warranty is in lieu of all other warranties, expressed or implied, and no person is authorized to assume for us any liability. Damages caused by normal wear and tear, misuse, abuse, neglect, accident, or improper installation and maintenance are not covered by this warranty.



Raven Industries
Flow Controls Division
P.O. Box 5107
Sioux Falls, SD 57117-5107

Toll Free 800-243-5435
Fax 605-331-0426
www.ravenprecision.com
fcinfo@ravenind.com

Notice: This document and the information provided are the property of Raven Industries, Inc. and may only be used as authorized by Raven Industries, Inc. All rights reserved under the copyright laws.