

RAVEN

Simply improving your position.SM

AutoBoom™ Installation Manual



Redball 690

Disclaimer

While every effort has been made to ensure the accuracy of this document, Raven Industries assumes no responsibility for omissions and errors. Nor is any liability assumed for damages resulting from the use of information contained herein.

Raven Industries shall not be held responsible or liable for the effects of atmospheric conditions and sunspot activity on the performance of our products. Raven Industries cannot guarantee the accuracy, integrity, continuity, or availability of the GPS signal from the U.S. Department of Defense/NAVSTAR GPS satellites, the OmniSTAR correction service, or the WAAS correction service. Raven Industries accepts no responsibility for the use of the signal for other than the stated purpose.

Raven Industries shall not be responsible or liable for incidental or consequential damages or a loss of anticipated benefits or profits, work stoppage or loss, or impairment of data arising out of the use, or inability to use, this system or any of its components.

Chapter 1	<i>Important Safety Information</i>	1
	Important Safety Information	1
	Hydraulic Safety	2
	Electrical Safety	2
Chapter 2	<i>Introduction</i>	3
	Introduction	3
	Recommendations	4
	Preparing for Installation	4
	Point of Reference	4
	Hydraulic Fittings	4
Chapter 3	<i>PowerGlide</i>	5
	PowerGlide Kit Contents	5
	Install the PowerGlide Hydraulic System	8
	Convert the Sprayer's Hydraulic Valve to Open Center (If Applicable)	9
	Install Fittings on the AutoBoom Valve	9
	Mount the AutoBoom Valve	10
	Install the Left and Right Cylinder Hoses	12
	PowerGlide Hydraulic Schematic	13
	Install the Gauge Wheels	14
	Gauge Wheel Mounting Locations	14
	Mount the Gauge Wheels	14
	Install the PowerGlide Wiring	15
	Connect the Harness to the Boom Function Controls	15
	Connect the Harness Cable to the Controller Cable	15
	Connect the Controller	16
	Connect the Power Leads	16
	PowerGlide Wiring Schematic	17
	AutoBoom Controller	17
Chapter 4	<i>PowerGlide Plus</i>	19
	PowerGlide Plus Kit Contents	19
	Install the PowerGlide Plus Hydraulic System	22
	Convert the Sprayer's Hydraulic Valve to Open Center (If Applicable)	23
	Remove the Orifice Fittings	23
	Install Fittings on the AutoBoom Valve	26
	Mount the AutoBoom Valve	26
	Install the Left and Right Cylinder Hoses	28
	PowerGlide Plus Hydraulic Schematic	30
	Install the Gauge Wheels	31
	Gauge Wheel Mounting Locations	31

Mount the Gauge Wheels 31

Install the PowerGlide Plus Wiring 32

 Install the AutoBoom Node 32

 Connect the Harness to the Boom Function Controls 32

 Connect the Harness Cable to the Controller Cable 33

 Connect the Controller (If Applicable) 34

 Connect the Field Computer (If Applicable) 34

 Connect the Power Leads 34

PowerGlide Plus Wiring Schematics 35

 AutoBoom Controller 35

 Envizio Plus 36

 SCS 4000/5000 37

 Viper Pro & Envizio Pro 38

Chapter 5 UltraGlide 39

UltraGlide Kit Contents 39

Install the UltraGlide Hydraulic System 43

 Convert the Sprayer’s Hydraulic Valve to Open Center (If Applicable) 44

 Install Fittings on the AutoBoom Valve 44

 Mount the AutoBoom Valve 45

 Install the Left and Right Cylinder Hoses 47

 UltraGlide Hydraulic Schematic 48

Install the UltraGlide Sensors 49

 Boom Sensor Mounting Locations 49

 Mount the Boom Sensors 49

 Mount the Center Rack Sensor 49

 Connect the Sensor Cables 50

Install the Gauge Wheels - Optional 51

 Gauge Wheel Mounting Locations 51

 Mount the Gauge Wheels 51

Install the UltraGlide Wiring 52

 Install the AutoBoom Node 52

 Connect the Harness to the Boom Function Controls 52

 Connect the Harness Cable to the Sensors 53

 Connect the Harness Cable to the Controller Cable 54

 Connect the Controller (If Applicable) 54

 Connect the Field Computer (If Applicable) 54

 Connect the Power Leads 54

UltraGlide Wiring Schematics 55

 AutoBoom Controller 55

 Envizio Plus 56

 SCS 4000/5000 57

 Viper Pro & Envizio Pro 58

Chapter 6 Replacement Parts 59

- Valve Blocks 59
 - PowerGlide Valve Replacement Parts 59
 - PowerGlide Plus and UltraGlide Valve Replacement Parts 60
- Wheels 60
- Sensors 61

CHAPTER

1

Important Safety Information

Important Safety Information

NOTICE

Read this manual and the operation and safety instructions included with your implement and/or controller carefully before installing the AutoBoom™ system.

- Follow all safety information presented within this manual.
- If you require assistance with any portion of the installation or service of your Raven equipment, contact your local Raven dealer for support.
- Follow all safety labels affixed to the AutoBoom system components. Be sure to keep safety labels in good condition and replace any missing or damaged labels. To obtain replacements for missing or damaged safety labels, contact your local Raven dealer.

When operating the machine after installing AutoBoom, observe the following safety measures:

- Be alert and aware of surroundings.
- Do not operate AutoBoom or any agricultural equipment while under the influence of alcohol or an illegal substance.
- Remain in the operator's position in the machine at all times when AutoBoom is engaged.
- Disable AutoBoom when exiting from the operator's seat and machine.
- Do not drive the machine with AutoBoom enabled on any public road.
- Determine and remain a safe working distance from other individuals. The operator is responsible for disabling AutoBoom when the safe working distance has been diminished.
- Ensure AutoBoom is disabled prior to starting any maintenance work on AutoBoom or the machine.

WARNING

- When starting the machine for the first time after installing AutoBoom, be sure that all persons stand clear, in case a hose has not been properly tightened.
- The machine must remain stationary and switched off, with the booms unfolded and supported while installation or maintenance is conducted.

CAUTION

Hydraulic Safety

- Raven Industries recommends that appropriate protective equipment be worn at all times when working on the hydraulic system.
- Never attempt to open or work on a hydraulic system with the equipment running. Care should always be taken when opening a system that has been previously pressurized.
- When disconnecting the hydraulic hoses or purging is required, be aware that the hydraulic fluid may be extremely hot and under high pressure. Caution must be exercised.
- Any work performed on the hydraulic system must be done in accordance with the machine manufacturer's approved maintenance instructions.
- When installing AutoBoom hydraulics or performing diagnostics, maintenance, or routine service, ensure that precautions are taken to prevent any foreign material or contaminants from being introduced into the machine's hydraulic system. Objects or materials that are able to bypass the machine's hydraulic filtration system will adversely reduce performance and possibly damage the AutoBoom hydraulic valves.

Electrical Safety

- Always verify that the power leads are connected to the correct polarity as marked. Reversing the power leads could cause severe damage to the equipment.
- Ensure that the power cable is the last cable to be connected.

CHAPTER

2

Introduction

Introduction

Congratulations on your purchase of the Raven AutoBoom system! This system is designed to provide automated boom height adjustment for agricultural equipment.

This manual applies to the following machines. For future reference, write your serial number in the space below.

MAKE: Redball

MODEL: 690

YEAR:

SERIAL NUMBER:

FIGURE 1. Redball 690



Note: *This manual contains the installation instructions for the PowerGlide, PowerGlide Plus, and UltraGlide systems. Be sure to identify which system you have and follow only the instructions for that system.*

Recommendations

Raven Industries recommends the following best practices when installing the AutoBoom system:

- Use part numbers to identify the parts.
- Do not remove the plastic wrap from a part until it is necessary for installation.
- Do not remove plastic caps from a part until it is necessary for installation.

Tools Needed

The following tools are recommended for installation of the AutoBoom system:

- SAE standard-sized wrenches
- Cable ties
- Set of tools

Preparing for Installation

Before installing AutoBoom, park the machine where the ground is level, clean, and dry. Leave the machine turned off for the duration of the installation process.

During the installation process, follow good safety practices. Be sure to carefully read the instructions in this manual as you complete the installation process.

Point of Reference

The instructions in this manual assume that you are standing behind the machine, looking toward the cab.

Hydraulic Fittings

This manual may reference the following types of hydraulic fittings:

- SAE O-ring fittings
- ORFS (O-Ring Face Seal)
- JIC fittings

SAE O-ring fitting



ORFS fitting



JIC fitting (M)



CHAPTER

3

PowerGlide

PowerGlide Kit Contents

This section contains a list of the components that are included in the PowerGlide AutoBoom kit. Before beginning the AutoBoom installation, compare the items in the AutoBoom kit with the components on this list. If you have questions about the kit, contact your Raven dealer.

Note: *In addition to the following kit components, an axle kit is required for the operation of the PowerGlide AutoBoom system. For available kits and ordering information, contact your local Raven dealer.*

TABLE 1. PowerGlide Installation Kit (P/N 117-0230-066)





Picture	Item Description	Part Number	Qty.
Not Pictured	Manual - Redball 690 AutoBoom Installation	016-0230-066	1
	Valve - PowerGlide AutoBoom	016-0131-127	1
	Plate - Hydraulic Block Mounting	107-0171-619	1
	Bracket - Redball Weldment Receiver	116-0159-537	2
	Wheel	322-0131-008	2

TABLE 1. PowerGlide Installation Kit (P/N 117-0230-066)











Picture	Item Description	Part Number	Qty.
	Cable - Boom Sense Adapter	115-0171-558	2
	Cable - PowerGlide/PowerGlide Plus/ UltraGlide Extension	115-0230-008	1
	U-Bolt - 3-1/16" W x 4" L x 3/8" Thread	107-0171-608	4
	U-Bolt - 4" W x 5" L x 3/8" Thread	107-0171-606	2
	Bolt - 5/16"-18 x 7/8" SS Hex	311-0052-104	4
	Bolt - 1/2"-13 x 1-1/2" SS Hex	311-0058-186	4
	Nut - 1/2"-13 Zinc Hex	312-1001-043	4
	Nut - 3/8"-16 Zinc Flanged Lock	312-1001-164	4
	Nut - 7/16"-14 Zinc Flanged Lock	312-1001-165	8
	Washer - 5/16" Zinc Plated Lock	313-1000-019	4

TABLE 2. Hydraulic Installation Kit (P/N 117-0134-035)

Picture	Item Description	Part Number	Qty.
	Fitting - 9/16" JIC M/F 90° Swivel Elbow	333-0012-042	2
	Fitting - 9/16" JIC M/M/F Swivel Run Tee Adapter	333-0012-043	1
	Fitting - 9/16" JIC (M) to 9/16" SAE O-Ring (M) Straight Adapter	333-0012-045	4
	Fitting - 9/16" JIC (M) to 3/4" SAE O-Ring (M) Straight Adapter	333-0012-046	3
	Hydraulic Hose - 9/16" JIC (F) to 9/16" JIC (F) 90° - 132'	214-1000-291	2
	Hydraulic Hose - 9/16" JIC (F) to 9/16" JIC (F) 90° - 72"	214-1000-292	2
	Hydraulic Hose - 9/16" JIC (F) to 9/16" JIC (M) - 64"	214-1000-387	1

TABLE 3. PowerGlide Wiring Kit (P/N 117-0137-022)





Picture	Item Description	Part Number	Qty.
Not Pictured	AutoBoom PowerGlide Calibration Operator's Manual	016-0130-061	1
	AutoBoom PowerGlide Controller	063-0130-011	1

TABLE 3. PowerGlide Wiring Kit (P/N 117-0137-022)

Picture	Item Description	Part Number	Qty.
	Cable - AutoBoom Controller	115-0230-002	1
	Cable - Harness	115-0230-003	1

Install the PowerGlide Hydraulic System



⚠ **WARNING**

The machine must remain stationary and switched off, with the booms unfolded and supported, during installation or maintenance.



⚠ **CAUTION**

When installing AutoBoom hydraulics or performing diagnostics, maintenance, or routine service, ensure precautions are taken to prevent any foreign material from being introduced into the machine's hydraulic system.

Objects or materials that are able to bypass the machine's hydraulic filtration system will reduce performance and possibly cause damage to the AutoBoom hydraulic valve.



NOTICE

The appearance of the AutoBoom hydraulic valve may vary slightly from the images contained in this manual. However, the fittings, hose connections, and cable connections remain the same.

Convert the Sprayer's Hydraulic Valve to Open Center (If Applicable)

By factory default, the machine's main hydraulic valve is configured as a "closed center" hydraulic system. In order for AutoBoom to function properly and to prevent the hydraulic system from overheating, Raven recommends converting the machine's hydraulic system to an "open center" system.

Note: Contact your sprayer dealer to obtain the open center conversion kit.

FIGURE 1. Converted Hydraulic Valve - Closed Center to Open Center

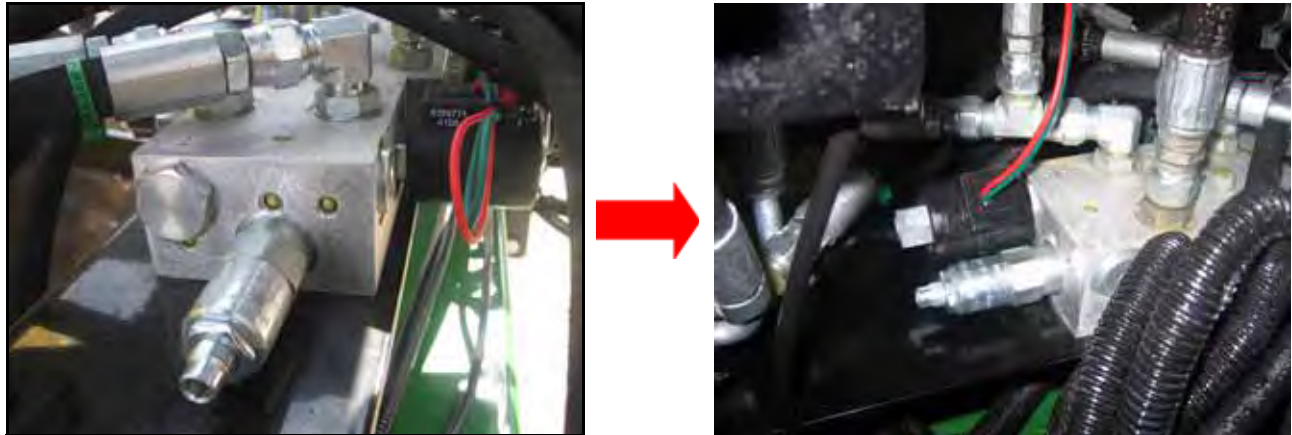

Install Fittings on the AutoBoom Valve

Before mounting the AutoBoom valve on the machine, install the proper fittings on the valve. This prepares the valve for installation and simplifies the hose connection process later in the procedure. Refer to the following table to install the fittings in the appropriate ports of the AutoBoom valve.

FIGURE 2. Fittings Installed on the AutoBoom Valve



Fitting	Part Number	Port
Fitting - 9/16" JIC (M) to 9/16" SAE O-Ring (M) Straight Adapter	333-0012-045	LC, RC LV, RV
Fitting - 9/16" JIC (M) to 3/4" SAE O-Ring (M) Straight Adapter	333-0012-046	P, T, EF
Fitting - 9/16" JIC M/F 90° Swivel Elbow	333-0012-042	P

Mount the AutoBoom Valve

FIGURE 3. AutoBoom Valve Mounted on the Valve Mounting Plate

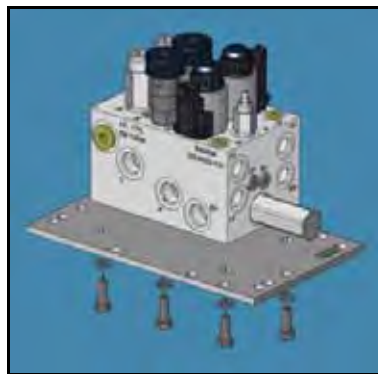

1. Secure the AutoBoom valve (P/N 063-0131-127) to the mounting plate (P/N 107-0171-619) using four 5/16"-18 x 7/8" hex bolts (P/N 311-0052-104) and four 5/16" lock washers (P/N 313-1000-019).

FIGURE 4. AutoBoom Valve Mounted to the Machine

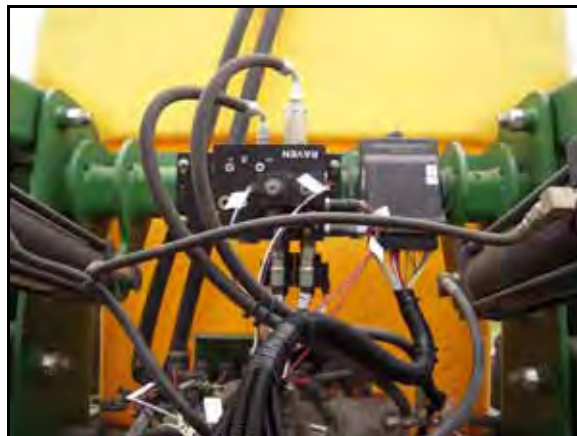

2. Secure the mounting plate the machine's center rack using two 4" W x 5" L x 3/8" thread U-bolts (P/N 107-0171-606) and four 3/8"-16 zinc flanged lock nuts (P/N 312-1001-164).

Install the Pressure and Tank Hoses



⚠ WARNING

Hydraulics are under pressure. Care should always be taken with a system that has been pressurized. When disconnecting or purging hydraulic hoses, be aware that the hydraulic fluid within the machine's system may be extremely hot and under high pressure.



⚠ CAUTION

When installing AutoBoom hydraulics or performing diagnostics, maintenance, or routine service, ensure precautions are taken to prevent any foreign material or contaminants from being introduced into the machine's hydraulic system.

Objects or materials that are able to bypass the machine's hydraulic filtration system will reduce performance and possibly cause damage to the AutoBoom hydraulic valve.

FIGURE 5. Pressure and Tank Hoses Installed



1. Locate and disconnect the pressure hose from port P of the machine's hydraulic valve.
2. Install the supplied hydraulic hose (P/N 214-1000-387) on the machine's pressure hose.
3. Connect the other end of the installed hydraulic hose to the installed fitting in Port P on the AutoBoom valve.
4. Install a 9/16" JIC M/F 90° swivel elbow fitting (P/N 333-0012-042) in port P of the machine's hydraulic valve.
5. Install the straight end of the supplied hydraulic hose (P/N 214-1000-292) on the installed fitting in port P of the machine's hydraulic valve.
6. Connect the 90° end of the installed hydraulic hose on the installed fitting in Port EF of the AutoBoom valve.
7. Locate and disconnect the tank hose from port T of the machine's hydraulic valve.

8. Install the 9/16" JIC M/M/F swivel run tee adapter fitting (P/N 333-0012-043) in port T of the machine's hydraulic valve.
9. Connect the machine's tank hose to the opposite end of the installed tee fitting.
10. Install the 90° end of the supplied hydraulic hose (P/N 214-1000-292) to the fitting installed in Port T of the AutoBoom valve.
11. Connect the straight end of the installed hydraulic hose to the 90° end of the installed tee fitting in port T of the machine's hydraulic valve.

Install the Left and Right Cylinder Hoses

FIGURE 6. Left and Right Cylinder Hoses Installed

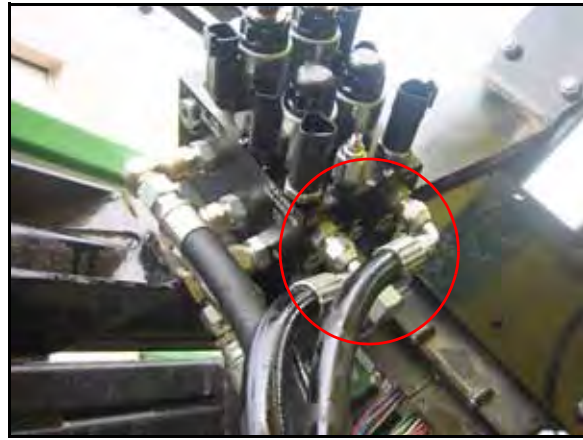

1. Disconnect the machine's cylinder up hoses from the machine's tilt cylinders.
2. Connect the machine's left cylinder hose to the installed fitting in Port LV of the AutoBoom valve.
3. Connect the machine's right cylinder hose to the installed fitting in Port RV of the AutoBoom valve.
4. Install the straight end of the supplied hydraulic hose (P/N 214-1000-291) to the installed fittings in Port LC of the AutoBoom valve.
5. Connect the 90° end of the installed hydraulic hose to the machine's left tilt cylinder.
6. Install the straight end of the supplied hydraulic hose (P/N 214-1000-291) on the installed fittings in Port RC of the AutoBoom valve.
7. Connect the 90° end of the installed hydraulic hose to the machine's right tilt cylinder.

PowerGlide Hydraulic Schematic

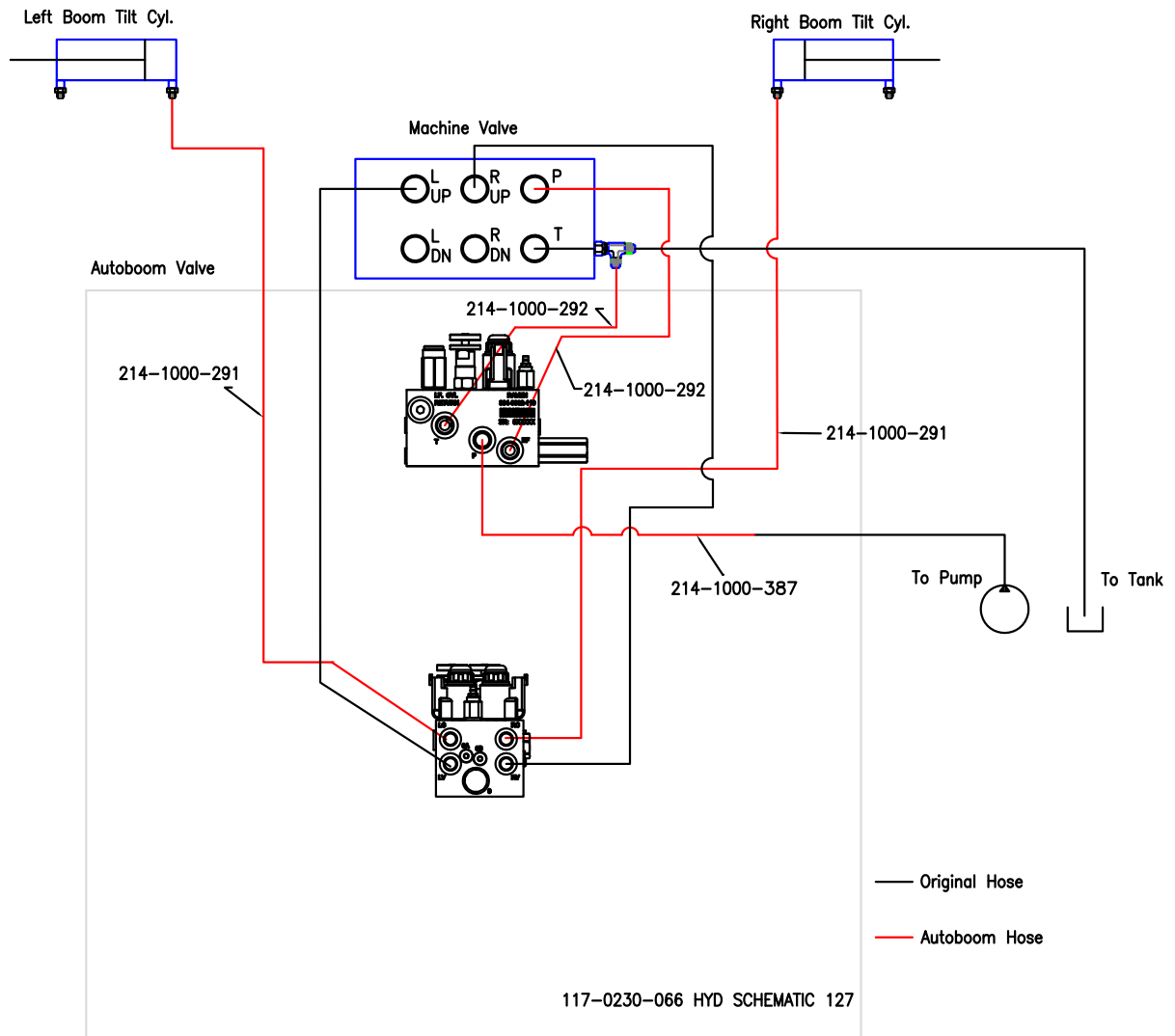

Install the Gauge Wheels

Gauge Wheel Mounting Locations

Wheel mounting locations may be influenced by the boom configuration. Determine the appropriate location for mounting the wheels on the boom, ensuring the wheels will not interfere with or be damaged while folding or unfolding the booms.

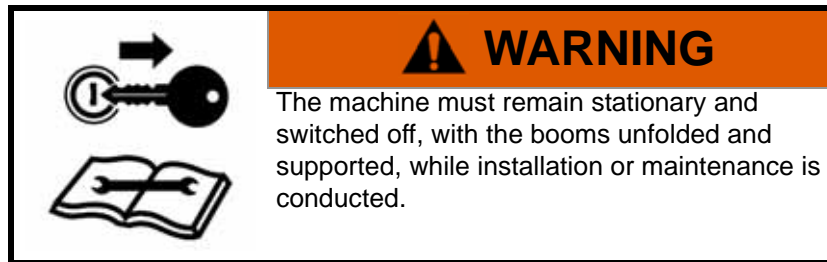

Mount the Gauge Wheels

Note: *The appearance of the wheel axles may vary, depending on the type of wheel axle kit that was ordered.*

FIGURE 7. Gauge Wheel Installed



1. Remove the nuts from the wheel axle.
2. Place the wheel (P/N 322-0131-008) on the wheel axle.
3. Reinstall the lug nuts on the wheel axle to secure the wheel.
4. Mount the receiver bracket (P/N 116-0159-537) to the front of the right boom inside the first fold joint using two 3-1/16" W x 4" L x 3/8" thread U-bolts (P/N 107-0171-608) and four 3/8"-16 zinc flanged lock nuts (P/N 312-1001-164).
5. Insert the wheel axle into the receiver bracket, positioning it so that the bottom of the wheel touches the ground (or nearly so) and the wheel faces away from the machine.
6. Secure the gauge wheel assembly in the wheel mounting bracket by installing two 1/2"-13 x 1-1/2" SS hex bolts (P/N 311-0058-186) and two 1/2"-13 zinc hex nuts (P/N 312-1001-043).
7. Repeat the steps above to install the left wheel.

Install the PowerGlide Wiring

Wiring Connections

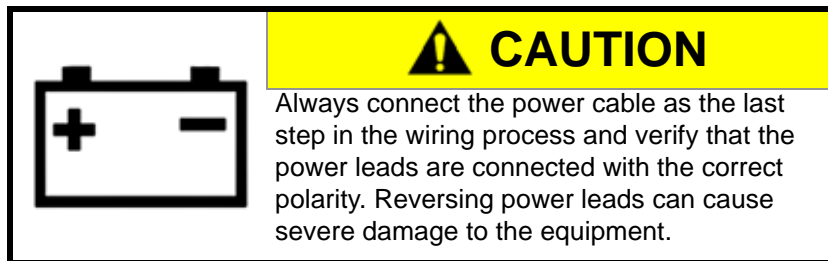

Note: For wiring connections made outside the cab, apply dielectric silicone grease (P/N 222-0000-006) generously on both the male and female ends of the connectors. Application of the grease will prevent corrosion to the pins and wires.

Connect the Harness to the Boom Function Controls

1. On the AutoBoom harness cable (P/N 115-0230-003), locate the Left Solenoid connector and connect it to Port 4A on the AutoBoom valve.
2. Connect the Right Solenoid connector to Port 4B on the AutoBoom valve.

FIGURE 8. Machine's Up Cylinder Wiring



3. Install the weatherpack boom sense adapter cables (P/N 115-0230-558) between the machine's cylinder Up coils and the connectors.
4. Connect the cable Up connectors on the Autoboom harness (P/N 115-0230-003) to the installed boom sense adapter cables.

Note: The system will now disengage when Up is pressed on the machine's controller. The system must be engaged via the AutoBoom controller or field computer screen.

Connect the Harness Cable to the Controller Cable

1. Route the harness cable (P/N 115-0230-003) toward the machine's cab.
2. Connect the harness cable to the controller cable (P/N 115-0230-002).
3. Tighten the connector cap to secure the connection.

Note: Be sure to allow enough slack in the harness cable to allow for boom racking. If the harness cable is not long enough, it may be necessary to connect the 12' extension cable (P/N 115-0230-008) between the harness and controller cables.

Connect the Controller

FIGURE 9. Controller Connections



1. Route the controller cable (P/N 115-0230-002) into the right side of the machine's cab.
2. Locate the two controller connectors and connect them to the AutoBoom controller (P/N 063-0130-011).

Note: The AutoBoom controller should be mounted in the machine's cab so that the operator has easy access to it.

Connect the Power Leads

1. Locate the power cable that has the red and white power leads at one end.
2. Disconnect the machine's connectors from the battery terminals.
3. Install the red power lead on the positive battery terminal and reinstall the machine's battery connector.
4. Install the white power lead on the negative battery terminal and reinstall the machine's battery connector.

PowerGlide Wiring Schematic

AutoBoom Controller

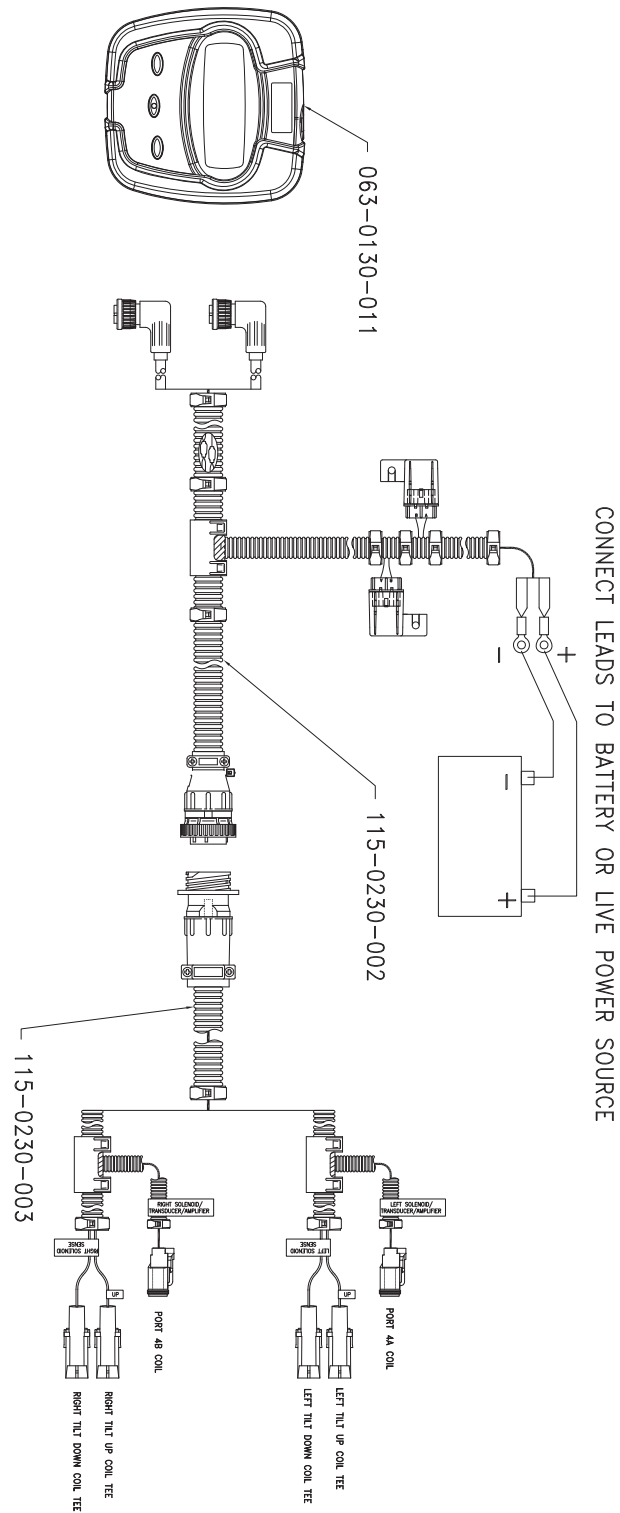

CHAPTER

4

PowerGlide Plus

PowerGlide Plus Kit Contents

This section contains a list of the components that are included in the PowerGlide Plus AutoBoom kit. Before beginning the AutoBoom installation, compare the items in the AutoBoom kit with the components on this list. If you have questions about the kit, contact your Raven dealer.

TABLE 1. PowerGlide Plus Installation Kit (P/N 117-0231-066)

Picture	Item Description	Part Number	Qty.
Not Pictured	Manual - Redball 690 AutoBoom Installation	016-0230-066	1
	Valve - PowerGlide Plus AutoBoom	063-0131-126	1
	Plate - Hydraulic Block Mounting	107-0171-802	1
	Cable - Boom Sense Adapter	115-0171-558	3
	Cable - Single Weatherpack Boom Sense Adapter	115-0171-790	1
	Cable - PowerGlide/PowerGlide Plus/ UltraGlide Extension	115-0230-008	1

TABLE 1. PowerGlide Plus Installation Kit (P/N 117-0231-066)

Picture	Item Description	Part Number	Qty.
	U-Bolt - 4" W x 5" L x 3/8" Thread	107-0171-606	2
	Bolt - 5/16"-18 x 7/8" Hex	311-0052-104	4
	Bolt - 3/8"-16 x 1-1/4" Zinc Hex	311-0054-106	3
	Nut - 3/8"-16 Zinc Flanged Lock	312-1001-164	7
	Washer - 5/16" Zinc Plated Lock	313-1000-019	4

TABLE 2. Hydraulic Installation Kit (P/N 117-0134-035)

Picture	Item Description	Part Number	Qty.
	Fitting - 9/16" JIC M/F 90° Swivel Elbow	333-0012-042	2
	Fitting - 9/16" JIC M/M/F Swivel Run Tee Adapter	333-0012-043	1
	Fitting - 9/16" JIC (M) to 9/16" SAE O-Ring (M) Straight Adapter	333-0012-045	4
	Fitting - 9/16" JIC (M) to 3/4" SAE O-Ring (M) Straight Adapter	333-0012-046	3
	Hydraulic Hose - 9/16" JIC (F) to 9/16" JIC (F) 90° - 132'	214-1000-291	2

TABLE 2. Hydraulic Installation Kit (P/N 117-0134-035)





Picture	Item Description	Part Number	Qty.
	Hydraulic Hose - 9/16" JIC (F) to 9/16" JIC (F) 90° - 72"	214-1000-292	2
	Hydraulic Hose - 9/16" JIC (F) to 9/16" JIC (M) - 64"	214-1000-387	1

TABLE 3. PowerGlide Plus Wheel Kit (P/N 117-0133-066)

Picture	Item Description	Part Number	Qty.
	Axle Assembly - 34" Straight Black	063-0131-566	2
	Bracket - Redball Weldment Receiver	116-0159-537	2
	Bracket - Hub Retainer	107-0171-617	2
	Wheel	322-0131-008	2
	U-Bolt - 3-1/16" W x 4" L x 3/8" Thread	107-0171-608	4
	Bolt - 1/2"-13 x 1-1/2" SS Hex	311-0058-186	4
	Nut - 1/2"-13 Zinc Hex	312-1001-043	4
	Nut - 3/8"-16 Zinc Flanged Lock	312-1001-164	8

TABLE 4. PowerGlide Plus Wiring Kit (P/N 117-0137-023)

Picture	Item Description	Part Number	Qty.
Not Pictured	CAN AutoBoom Calibration & Operation Manual	016-0130-062	1
	AutoBoom Node	063-0130-010	1
	Cable - Harness	115-0230-045	1
	Cable - Power/CAN	115-0230-007	1

Install the PowerGlide Plus Hydraulic System



 **WARNING**

The machine must remain stationary and switched off, with the booms unfolded and supported, during installation or maintenance.



 **CAUTION**

When installing AutoBoom hydraulics or performing diagnostics, maintenance, or routine service, ensure precautions are taken to prevent any foreign material from being introduced into the machine's hydraulic system.

Objects or materials that are able to bypass the machine's hydraulic filtration system will reduce performance and possibly cause damage to the AutoBoom hydraulic valve.

	<p style="text-align: center;">NOTICE</p> <p>The appearance of the AutoBoom hydraulic valve may vary slightly from the images contained in this manual. However, the fittings, hose connections, and cable connections remain the same.</p>
---	--

Convert the Sprayer's Hydraulic Valve to Open Center (If Applicable)

By factory default, the machine's main hydraulic valve is configured as a "closed center" hydraulic system. In order for AutoBoom to function properly and to prevent the hydraulic system from overheating, Raven recommends converting the machine's hydraulic system to an "open center" system.

Note: Contact your sprayer dealer to obtain the open center conversion kit.

FIGURE 1. Converted Hydraulic Valve - Closed Center to Open Center

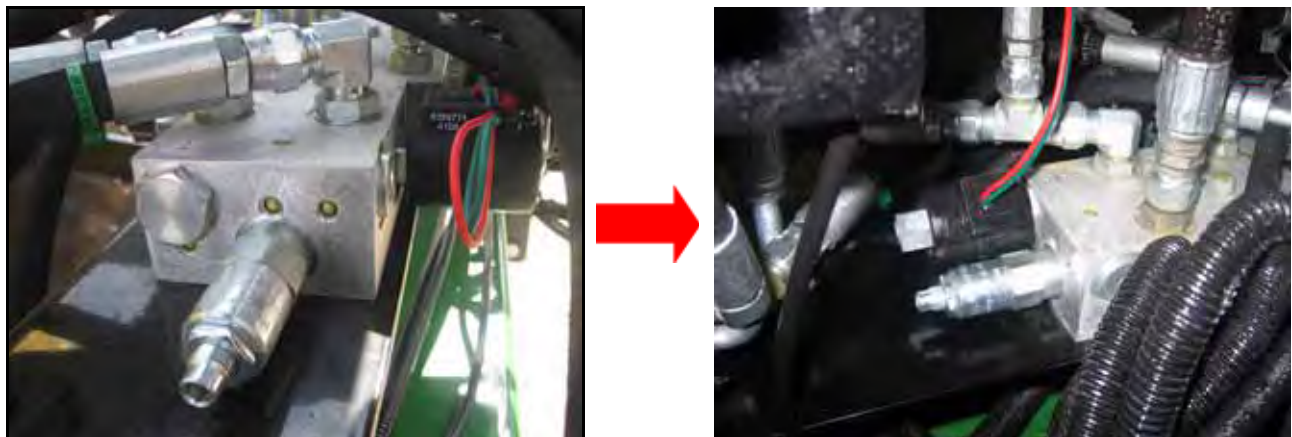

Remove the Orifice Fittings

Before populating the hydraulic fittings on the AutoBoom valve, it is necessary to remove orifice fittings from the valve in the PowerGlide Plus system. Failure to remove these fittings from the valve will restrict the down speed of the booms when the system is enabled.

FIGURE 2. Port 3A and 3B Location



1. Locate Ports 3A and 3B on the AutoBoom valve (P/N 063-0131-126).

FIGURE 3. Coil Removed from the AutoBoom Valve



2. Remove the coils from the solenoids near Ports 3A and 3B to gain easy access to those ports.

FIGURE 4. Port Plugs Removed from the AutoBoom Valve

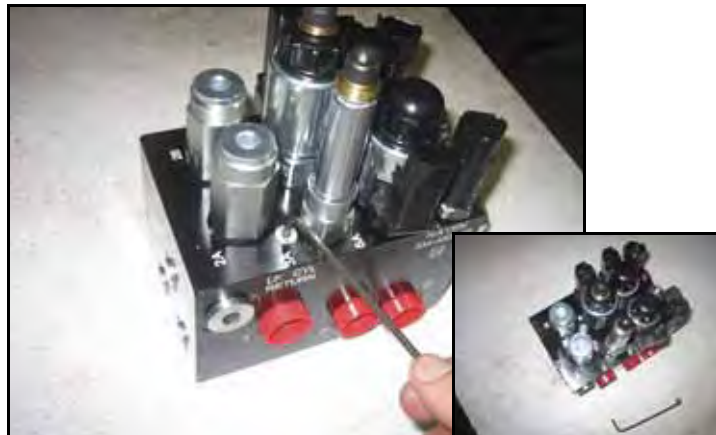

3. Use an Allen wrench to remove the plugs from Ports 3A and 3B.

FIGURE 5. Orifice Fitting Removed from the AutoBoom Valve



Orifice Fitting
Removed - Keep for
Future Use

4. Remove the orifice fittings from Ports 3A and 3B.

Important: *Tip the AutoBoom valve on its side and use the Allen wrench to remove the orifice from the cavity, taking care not to let the fitting fall into the valve.*

FIGURE 6. Port Plug Reinstalled on the AutoBoom Valve



5. Use the Allen wrench to reinstall the port plugs on Ports 3A and 3B of the AutoBoom valve.

FIGURE 7. Coil Reinstalled on the AutoBoom Valve



6. Reinstall the coils on the solenoids of the AutoBoom valve.

Install Fittings on the AutoBoom Valve

Before mounting the AutoBoom valve on the machine, install the proper fittings on the valve. This prepares the valve for installation and simplifies the hose connection process later in the procedure. Refer to the following table to install the fittings in the appropriate ports of the AutoBoom valve.

FIGURE 8. Fittings Installed on the AutoBoom Valve



Fitting	Part Number	Port
Fitting - 9/16" JIC (M) to 9/16" SAE O-Ring (M) Straight Adapter	333-0012-045	LC, RC LV, RV
Fitting - 9/16" JIC (M) to 3/4" SAE O-Ring (M) Straight Adapter	333-0012-046	P, T, EF
Fitting - 9/16" JIC M/F 90° Swivel Elbow	333-0012-042	P

Mount the AutoBoom Valve

FIGURE 9. AutoBoom Valve Mounted on the Valve Mounting Plate

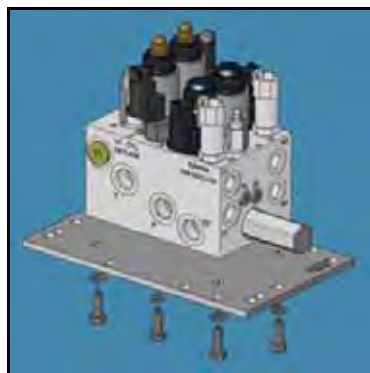

1. Secure the AutoBoom valve (P/N 063-0131-126) to the mounting plate (P/N 107-0171-802) using four 5/16"-18 x 7/8" hex bolts (P/N 311-0052-104) and four 5/16" lock washers (P/N 313-1000-019).

FIGURE 10. AutoBoom Valve Mounted to the Machine



2. Secure the mounting plate the machine's center rack using two 4" W x 5" L x 3/8" thread U-bolts (P/N 107-0171-606) and four 3/8"-16 zinc flanged lock nuts (P/N 312-1001-164).

Install the Pressure and Tank Hoses



WARNING

Hydraulics are under pressure. Care should always be taken with a system that has been pressurized. When disconnecting or purging hydraulic hoses, be aware that the hydraulic fluid within the machine's system may be extremely hot and under high pressure.



CAUTION

When installing AutoBoom hydraulics or performing diagnostics, maintenance, or routine service, ensure precautions are taken to prevent any foreign material or contaminants from being introduced into the machine's hydraulic system.

Objects or materials that are able to bypass the machine's hydraulic filtration system will reduce performance and possibly cause damage to the AutoBoom hydraulic valve.

FIGURE 11. Pressure and Tank Hoses Installed



1. Locate and disconnect the pressure hose from port P of the machine's hydraulic valve.
2. Install the supplied hydraulic hose (P/N 214-1000-387) on the machine's pressure hose.
3. Connect the other end of the installed hydraulic hose to the installed fitting in Port P on the AutoBoom valve.
4. Install a 9/16" JIC M/F 90° swivel elbow fitting (P/N 333-0012-042) in port P of the machine's hydraulic valve.
5. Install the straight end of the supplied hydraulic hose (P/N 214-1000-292) on the installed fitting in port P of the machine's hydraulic valve.
6. Connect the 90° end of the installed hydraulic hose on the installed fitting in Port EF of the AutoBoom valve.
7. Locate and disconnect the tank hose from port T of the machine's hydraulic valve.
8. Install the 9/16" JIC M/M/F swivel run tee adapter fitting (P/N 333-0012-043) in port T of the machine's hydraulic valve.
9. Connect the machine's tank hose to the opposite end of the installed tee fitting.
10. Install the 90° end of the supplied hydraulic hose (P/N 214-1000-292) to the fitting installed in Port T of the AutoBoom valve.
11. Connect the straight end of the installed hydraulic hose to the 90° end of the installed tee fitting in port T of the machine's hydraulic valve.

Install the Left and Right Cylinder Hoses

FIGURE 12. Left and Right Cylinder Hoses Installed



1. Disconnect the machine's cylinder up hoses from the machine's tilt cylinders.
2. Connect the machine's left cylinder hose to the installed fitting in Port LV of the AutoBoom valve.
3. Connect the machine's right cylinder hose to the installed fitting in Port RV of the AutoBoom valve.
4. Install the straight end of the supplied hydraulic hose (P/N 214-1000-291) to the installed fittings in Port LC of the AutoBoom valve.
5. Connect the 90° end of the installed hydraulic hose to the machine's left tilt cylinder.
6. Install the straight end of the supplied hydraulic hose (P/N 214-1000-291) on the installed fittings in Port RC of the AutoBoom valve.
7. Connect the 90° end of the installed hydraulic hose to the machine's right tilt cylinder.



PowerGlide Plus Hydraulic Schematic

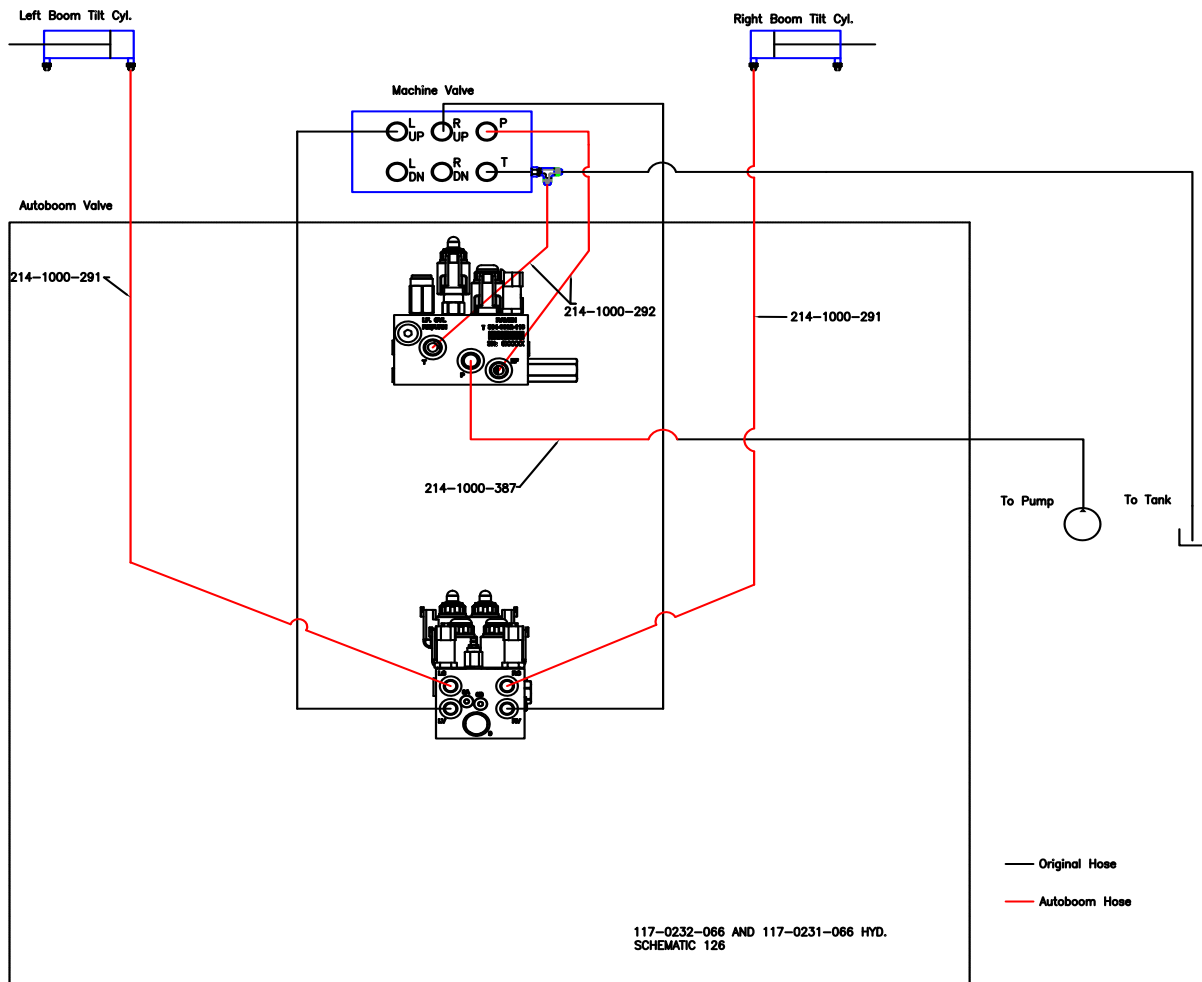

Install the Gauge Wheels

Gauge Wheel Mounting Locations

Wheel mounting locations may be influenced by the boom configuration. Determine the appropriate location for mounting the wheels on the boom, ensuring the wheels will not interfere with or be damaged while folding or unfolding the booms.

	<p style="text-align: center;">⚠ WARNING</p> <p>The machine must remain stationary and switched off, with the booms unfolded and supported, while installation or maintenance is conducted.</p>
---	--

Mount the Gauge Wheels

Note: *The appearance of the wheel axles may vary.*

FIGURE 13. Gauge Wheel Installed



1. Remove the nuts from the wheel axle (P/N 063-0131-566).
2. Place the wheel (P/N 322-0131-008) on the wheel axle.
3. Reinstall the lug nuts on the wheel axle to secure the wheel.
4. Mount the receiver bracket (P/N 116-0159-537) to the front of the right boom inside the first fold joint using two 3-1/16" W x 4" L x 3/8" thread U-bolts (P/N 107-0171-608) and four 3/8"-16 zinc flanged lock nuts (P/N 312-1001-164).
5. Insert the wheel axle into the receiver bracket, positioning it so that the bottom of the wheel touches the ground (or nearly so) and the wheel faces away from the machine.
6. Secure the gauge wheel assembly in the wheel mounting bracket by installing two 1/2"-13 x 1-1/2" SS hex bolts (P/N 311-0058-186) and two 1/2"-13 zinc hex nuts (P/N 312-1001-043).
7. Repeat the steps above to install the left wheel.

Install the PowerGlide Plus Wiring

Wiring Connections

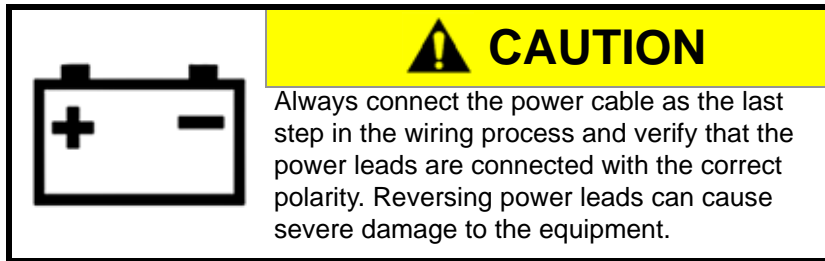

Note: For wiring connections made outside the cab, apply dielectric silicone grease (P/N 222-0000-006) generously on both the male and female ends of the connectors. Application of the grease will prevent corrosion to the pins and wires.

Install the AutoBoom Node

1. Mount the AutoBoom node (P/N 063-0130-010) to the valve mounting plate (P/N 107-0171-802) next to the AutoBoom valve using three 3/8"-16 UNC x 1-1/4" zinc plated hex bolts (P/N 311-0054-106) and three 3/8"-16 zinc flanged lock nuts (P/N 312-1001-164).

Note: Position the node so that the cable connectors face down.

2. Insert the large, rectangular node connector on the harness cable (P/N 115-0230-045) into the left port of the AutoBoom valve.
3. Tighten the bolt on the node connector to secure the connection.

Connect the Harness to the Boom Function Controls

1. Locate the Left Press and Right Press connectors on the harness cable (P/N 115-0230-045).
2. Route the connectors to the AutoBoom valve (P/N 063-0131-126).
3. Connect the Left Press connector to Port G1 on the AutoBoom valve.
4. Connect the Right Press connector to Port G4 on the AutoBoom valve.
5. Locate the Left Solenoid and Right Solenoid connectors on the harness cable.
6. Connect the Left Solenoid connector to Port 4A on the AutoBoom valve.
7. Connect the Right Solenoid connector to Port 4B on the AutoBoom valve.
8. Locate the Left Prop and Right Prop connectors on the harness cable.
9. Connect the Left Prop connector to Port 5A on the AutoBoom valve.
10. Connect the Right Prop connector to Port 13A on the AutoBoom valve.

FIGURE 14. Directional Valve Boom Sense Adapter Cables Installed

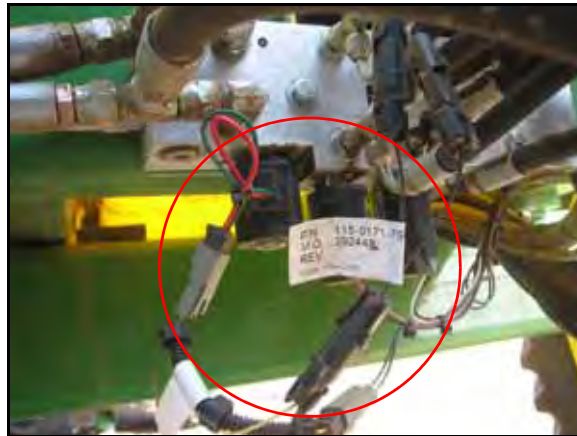

11. Locate the machine's directional valve.
12. Disconnect the machine's directional valve connector from the directional valve.
13. Install a boom sense adapter cable (P/N 115-0171-558) on the machine's directional valve connector.
14. Install the single weatherpack boom sense adapter cable (P/N 115-0171-790) on the installed boom sense adapter cable.
15. Connect the Right Down and Left Down connectors on the AutoBoom harness cable (P/N 115-0230-045) to the connectors on the installed weatherpack boom sense adapter cable (P/N 115-0171-790).

FIGURE 15. Machine's Up Cylinder Wiring



16. Install boom sense adapter cables (P/N 115-0171-558) between the machine's cylinder up coils and the connectors.
17. Connect the cable connectors to the Right Up and Left Up connectors on the AutoBoom harness (P/N 115-0230-045) to the installed boom sense adapter cables.

Connect the Harness Cable to the Controller Cable

1. Route the harness cable (P/N 115-0230-045) toward the machine's cab.
2. Connect the harness cable to the controller cable (P/N 115-0230-007).
3. Tighten the connector cap to secure the connection.

Note: Be sure to allow enough slack in the harness cable to allow for boom racking.

Connect the Controller (If Applicable)

1. Route the controller cable (P/N 115-0230-007) into the right side of the machine's cab.
2. Locate the two controller connectors and connect them to the AutoBoom controller (P/N 063-0130-011).

Note: *The AutoBoom controller should be mounted in the machine's cab so that the operator has easy access to it.*

Connect the Field Computer (If Applicable)

Refer to the Installation & Operation Manual and the appropriate wiring schematic beginning on page 35 for installation and wiring instructions for your specific field computer.

Connect the Power Leads

1. Locate the power cable that has the red and white power leads at one end.
2. Disconnect the machine's connectors from the battery terminals.
3. Install the red power lead on the positive battery terminal and reinstall the machine's battery connector.
4. Install the white power lead on the negative battery terminal and reinstall the machine's battery connector.

PowerGlide Plus Wiring Schematics

AutoBoom Controller

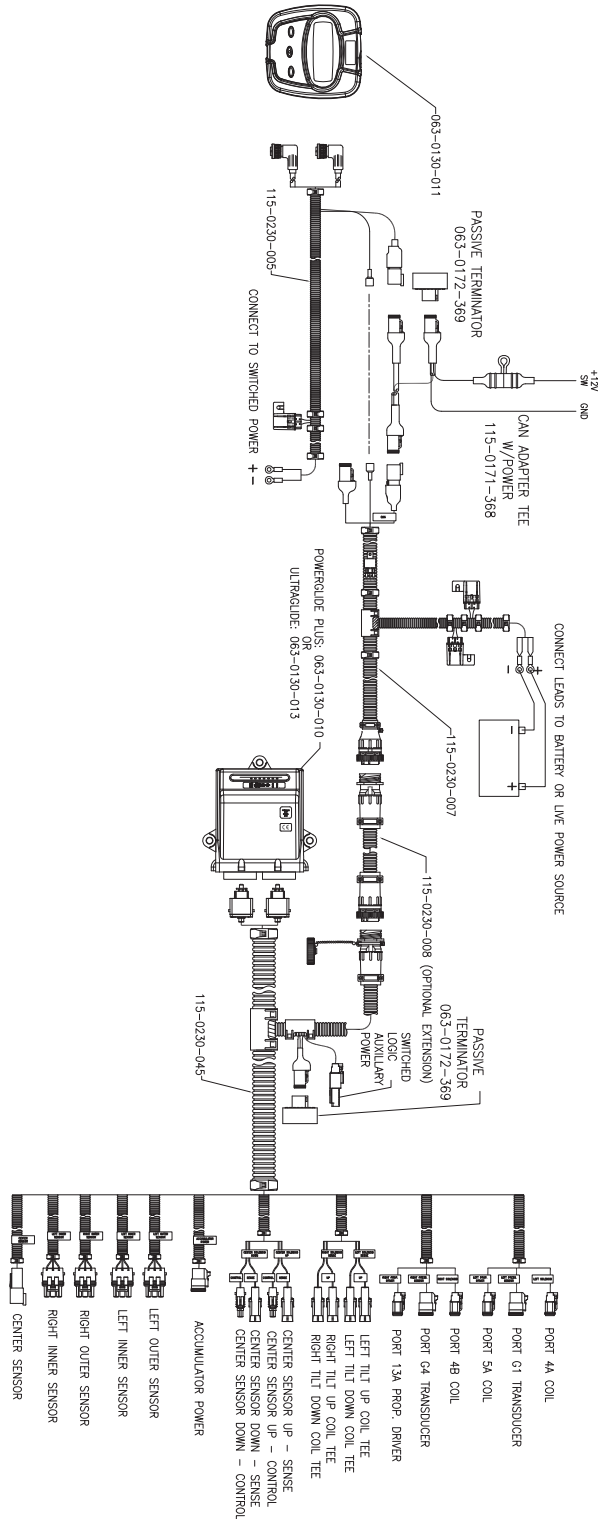

Envizio Plus

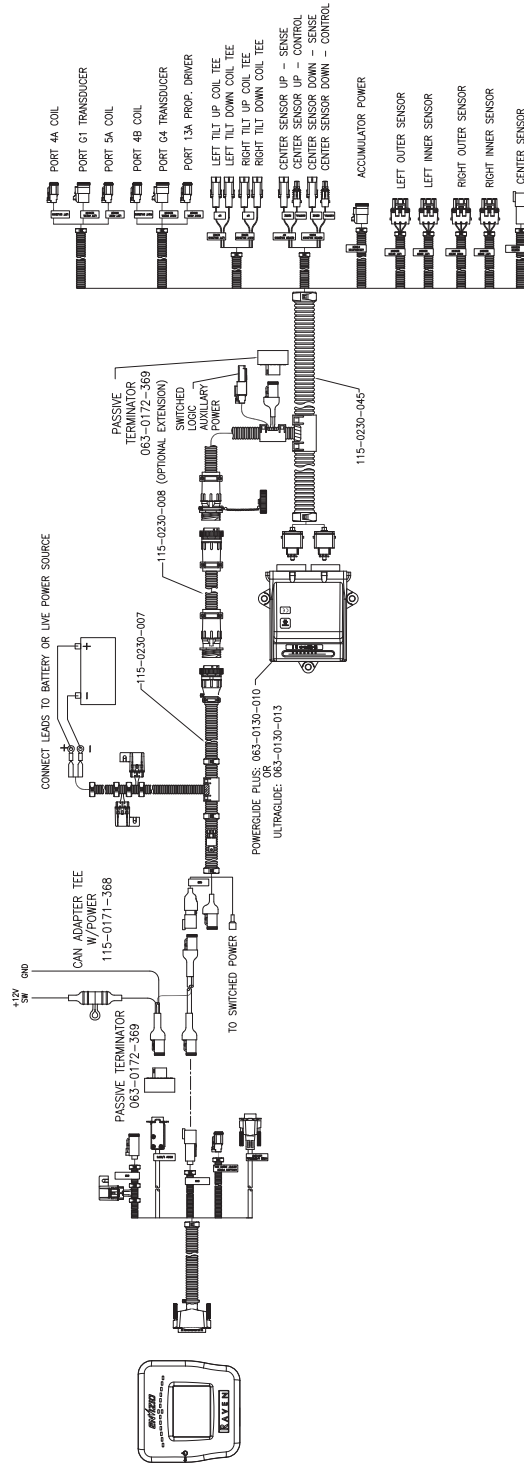

SCS 4000/5000

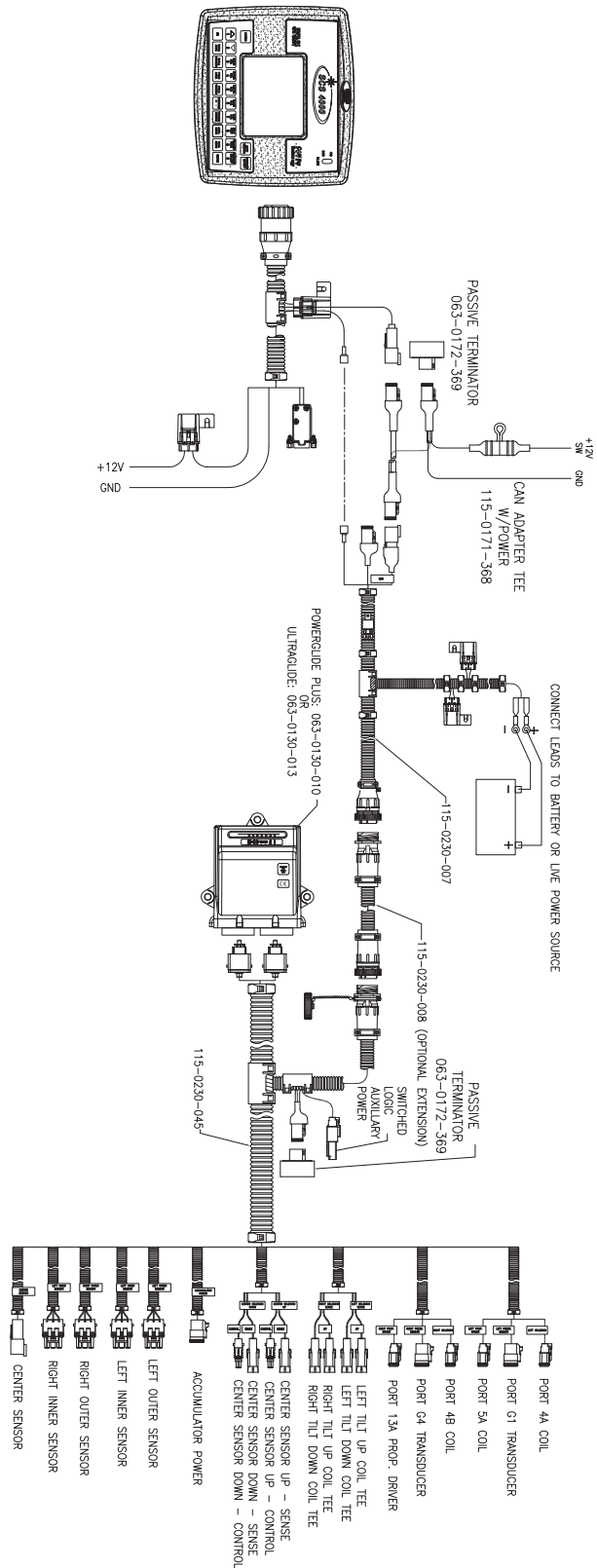

Viper Pro & Envizio Pro

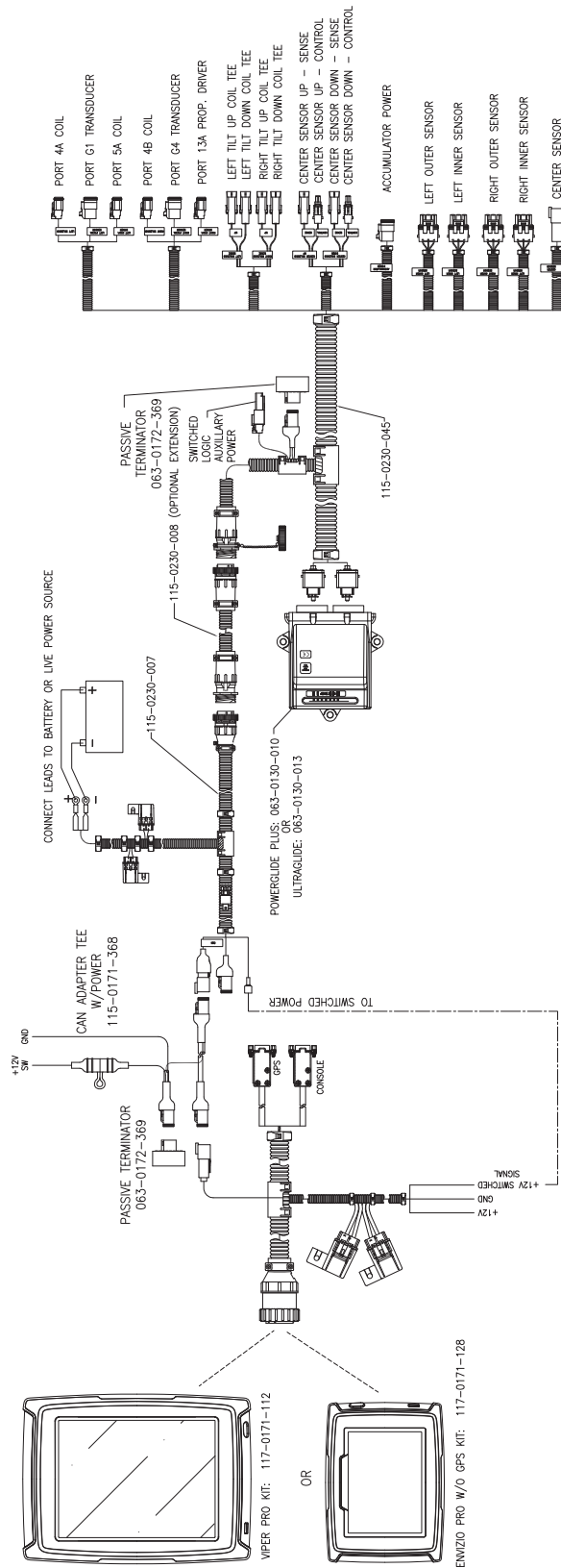

UltraGlide Kit Contents

This section contains a list of the components that are included in the UltraGlide AutoBoom kit. Before beginning the AutoBoom installation, compare the items in the AutoBoom kit with the components on this list. If you have questions about the kit, contact your Raven dealer.

TABLE 1. UltraGlide Installation Kit (P/N 117-0232-066)

Picture	Item Description	Part Number	Qty.
Not Pictured	Manual - Redball 690 AutoBoom Installation	016-0230-066	1
	Valve - PowerGlide Plus AutoBoom	063-0131-126	1
	Plate - Hydraulic Block Mounting	107-0171-802	1
	Sensor - Right Ultrasonic	063-0130-012	1
	Sensor - Left Ultrasonic	063-0130-014	1
	Sensor - Center Ultrasonic	063-0130-018	1

TABLE 1. UltraGlide Installation Kit (P/N 117-0232-066)

Picture	Item Description	Part Number	Qty.
	Cable - 2-Pin Weatherpack Boom Sense Adapter	115-0171-558	3
	Cable - Single Weatherpack Boom Sense Adapter	115-0171-790	1
	Cable - PowerGlide/PowerGlide Plus/ UltraGlide Extension	115-0230-008	1
	U-Bolt - 4" W x 5" L x 3/8" Thread	107-0171-606	2
	U-Bolt - 1-9/16" W x 2-1/2" L x 3/8" Thread	107-0171-611	6
	Bolt - 5/16"-18 x 7/8" SS Hex	311-0052-104	4
	Bolt - 3/8"-16 x 1-1/4" Zinc Hex	311-0054-106	3
	Nut - 3/8"-16 Zinc Flanged Lock	312-1001-164	19
	Washer - 5/16" Zinc Plated Lock	313-1000-019	4

TABLE 2. Hydraulic Installation Kit (P/N 117-0134-035)

Picture	Item Description	Part Number	Qty.
	Fitting - 9/16" JIC M/F 90° Swivel Elbow	333-0012-042	2
	Fitting - 9/16" JIC M/M/F Swivel Run Tee Adapter	333-0012-043	1
	Fitting - 9/16" JIC (M) to 9/16" SAE O-Ring (M) Straight Adapter	333-0012-045	4
	Fitting - 9/16" JIC (M) to 3/4" SAE O-Ring (M) Straight Adapter	333-0012-046	3
	Hydraulic Hose - 9/16" JIC (F) to 9/16" JIC (F) 90° - 132'	214-1000-291	2
	Hydraulic Hose - 9/16" JIC (F) to 9/16" JIC (F) 90° - 72"	214-1000-292	2
	Hydraulic Hose - 9/16" JIC (F) to 9/16" JIC (M) - 64"	214-1000-387	1

TABLE 3. PowerGlide Plus Wheel Kit (P/N 117-0133-066)



Picture	Item Description	Part Number	Qty.
	Axle Assembly - 34" Straight Black	063-0131-566	2
	Bracket - Redball Weldment Receiver	116-0159-537	2
	Bracket - Hub Retainer	107-0171-617	2



TABLE 3. PowerGlide Plus Wheel Kit (P/N 117-0133-066)









Picture	Item Description	Part Number	Qty.
	Wheel	322-0131-008	2
	U-Bolt - 3-1/16" W x 4" L x 3/8" Thread	107-0171-608	4
	Bolt - 1/2"-13 x 1-1/2" SS Hex	311-0058-186	4
	Nut - 1/2"-13 Zinc Hex	312-1001-043	4
	Nut - 3/8"-16 Zinc Flanged Lock	312-1001-164	8

TABLE 4. UltraGlide Wiring Kit (P/N 117-0137-024)

Picture	Item Description	Part Number	Qty.
Not Pictured	CAN AutoBoom Calibration & Operation Manual	016-0130-062	1
	AutoBoom Node	063-0130-013	1
	Cable - Sensor	115-0171-527	2
	Cable - Harness	115-0230-045	1
	Cable - Power/CAN	115-0230-007	1

Install the UltraGlide Hydraulic System

	<p>⚠ WARNING</p> <p>The machine must remain stationary and switched off, with the booms unfolded and supported, during installation or maintenance.</p>
---	--

	<p>⚠ CAUTION</p> <p>When installing AutoBoom hydraulics or performing diagnostics, maintenance, or routine service, ensure precautions are taken to prevent any foreign material from being introduced into the machine's hydraulic system.</p> <p>Objects or materials that are able to bypass the machine's hydraulic filtration system will reduce performance and possibly cause damage to the AutoBoom hydraulic valve.</p>
---	---

	<p>NOTICE</p> <p>The appearance of the AutoBoom hydraulic valve may vary slightly from the images contained in this manual. However, the fittings, hose connections, and cable connections remain the same.</p>
---	--



Convert the Sprayer's Hydraulic Valve to Open Center (If Applicable)

By factory default, the machine's main hydraulic valve is configured as a "closed center" hydraulic system. In order for AutoBoom to function properly and to prevent the hydraulic system from overheating, Raven recommends converting the machine's hydraulic system to an "open center" system.

Note: Contact your sprayer dealer to obtain the open center conversion kit.

FIGURE 1. Converted Hydraulic Valve - Closed Center to Open Center

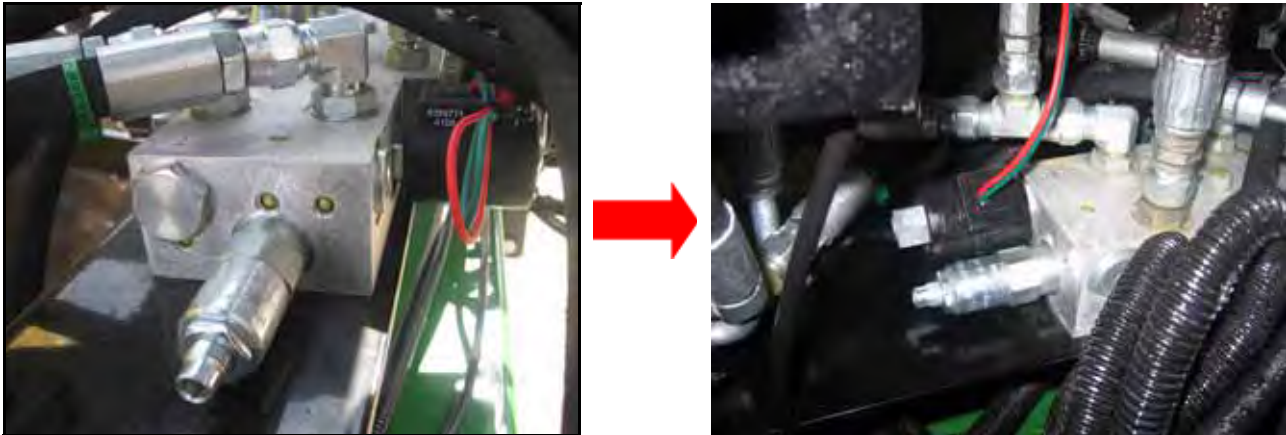

Install Fittings on the AutoBoom Valve

Before mounting the AutoBoom valve on the machine, install the proper fittings on the valve. This prepares the valve for installation and simplifies the hose connection process later in the procedure. Refer to the following table to install the fittings in the appropriate ports of the AutoBoom valve.

FIGURE 2. Fittings Installed on the AutoBoom Valve



Fitting	Part Number	Port
Fitting - 9/16" JIC (M) to 9/16" SAE O-Ring (M) Straight Adapter	333-0012-045	LC, RC LV, RV
Fitting - 9/16" JIC (M) to 3/4" SAE O-Ring (M) Straight Adapter	333-0012-046	P, T, EF
Fitting - 9/16" JIC M/F 90° Swivel Elbow	333-0012-042	P

Mount the AutoBoom Valve

FIGURE 3. AutoBoom Valve Mounted on the Valve Mounting Plate

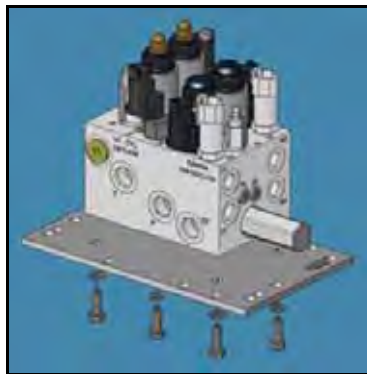

1. Secure the AutoBoom valve (P/N 063-0131-126) to the mounting plate (P/N 107-0171-802) using four 5/16"-18 x 7/8" hex bolts (P/N 311-0052-104) and four 5/16" lock washers (P/N 313-1000-019).

FIGURE 4. AutoBoom Valve Mounted to the Machine

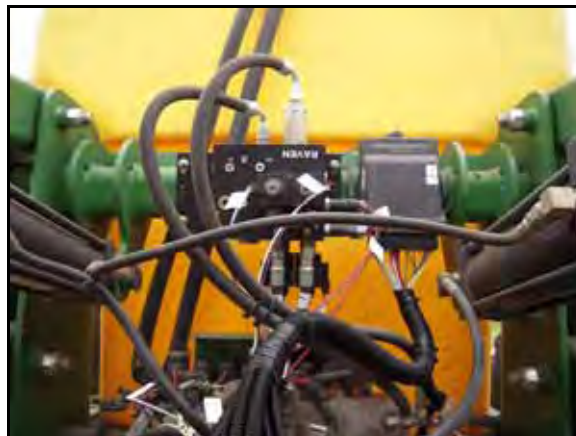

2. Secure the mounting plate the machine's center rack using two 4" W x 5" L x 3/8" thread U-bolts (P/N 107-0171-606) and four 3/8"-16 zinc flanged lock nuts (P/N 312-1001-164).

Install the Pressure and Tank Hoses

	<p>⚠ WARNING</p> <p>Hydraulics are under pressure. Care should always be taken with a system that has been pressurized. When disconnecting or purging hydraulic hoses, be aware that the hydraulic fluid within the machine's system may be extremely hot and under high pressure.</p>
---	---

	<p>⚠ CAUTION</p> <p>When installing AutoBoom hydraulics or performing diagnostics, maintenance, or routine service, ensure precautions are taken to prevent any foreign material or contaminants from being introduced into the machine's hydraulic system.</p> <p>Objects or materials that are able to bypass the machine's hydraulic filtration system will reduce performance and possibly cause damage to the AutoBoom hydraulic valve.</p>
---	---

FIGURE 5. Pressure and Tank Hoses Installed



1. Locate and disconnect the pressure hose from port P of the machine's hydraulic valve.
2. Install the supplied hydraulic hose (P/N 214-1000-387) on the machine's pressure hose.
3. Connect the other end of the installed hydraulic hose to the installed fitting in Port P on the AutoBoom valve.
4. Install a 9/16" JIC M/F 90° swivel elbow fitting (P/N 333-0012-042) in port P of the machine's hydraulic valve.
5. Install the straight end of the supplied hydraulic hose (P/N 214-1000-292) on the installed fitting in port P of the machine's hydraulic valve.
6. Connect the 90° end of the installed hydraulic hose on the installed fitting in Port EF of the AutoBoom valve.
7. Locate and disconnect the tank hose from port T of the machine's hydraulic valve.

8. Install the 9/16" JIC M/M/F swivel run tee adapter fitting (P/N 333-0012-043) in port T of the machine's hydraulic valve.
9. Connect the machine's tank hose to the opposite end of the installed tee fitting.
10. Install the 90° end of the supplied hydraulic hose (P/N 214-1000-292) to the fitting installed in Port T of the AutoBoom valve.
11. Connect the straight end of the installed hydraulic hose to the 90° end of the installed tee fitting in port T of the machine's hydraulic valve.

Install the Left and Right Cylinder Hoses

FIGURE 6. Left and Right Cylinder Hoses Installed

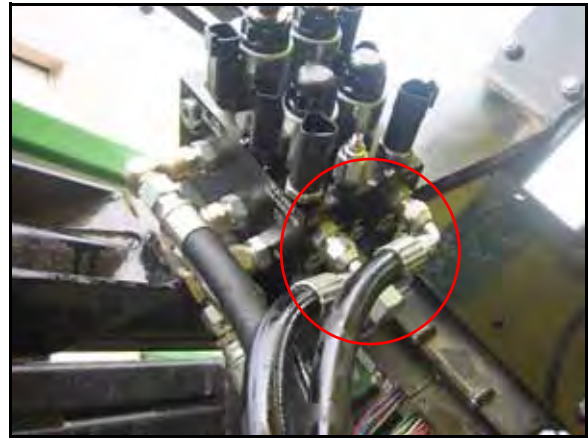

1. Disconnect the machine's cylinder up hoses from the machine's tilt cylinders.
2. Connect the machine's left cylinder hose to the installed fitting in Port LV of the AutoBoom valve.
3. Connect the machine's right cylinder hose to the installed fitting in Port RV of the AutoBoom valve.
4. Install the straight end of the supplied hydraulic hose (P/N 214-1000-291) to the installed fittings in Port LC of the AutoBoom valve.
5. Connect the 90° end of the installed hydraulic hose to the machine's left tilt cylinder.
6. Install the straight end of the supplied hydraulic hose (P/N 214-1000-291) on the installed fittings in Port RC of the AutoBoom valve.
7. Connect the 90° end of the installed hydraulic hose to the machine's right tilt cylinder.

UltraGlide Hydraulic Schematic

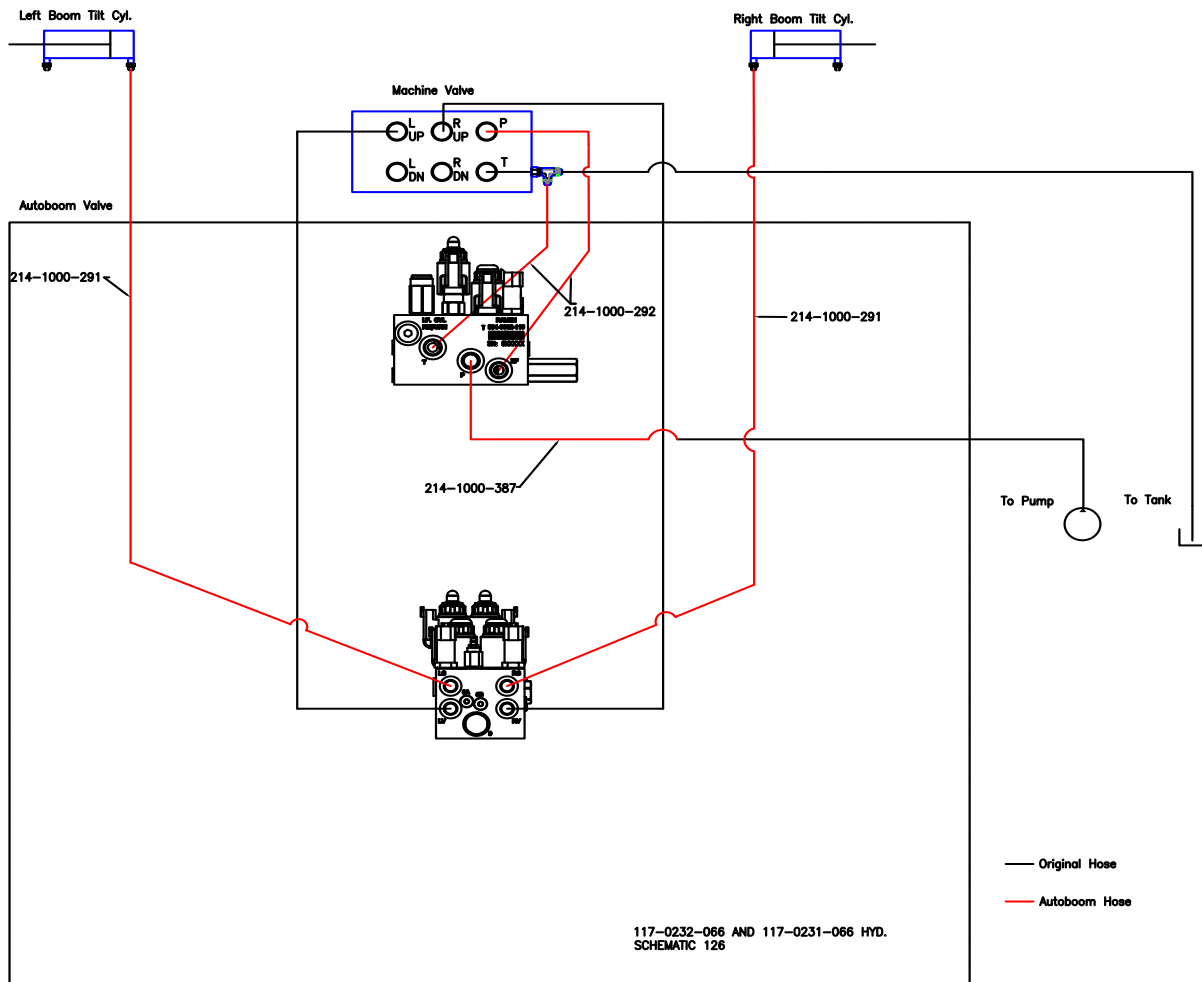

Install the UltraGlide Sensors

Boom Sensor Mounting Locations

Sensor mounting locations may be influenced by the boom configuration. Determine the appropriate location for mounting the sensors on the boom, ensuring the sensors will not interfere with or be damaged while folding or unfolding the booms. The sensors should be mounted outside of the boom fold, but inside of the boom breakaway.

Mount the Boom Sensors

FIGURE 7. Mounted Boom Sensor



1. Secure the left sensor (P/N 063-0130-014) to the front of the left boom using two 1-9/16" W x 2-1/2" L x 3/8" thread U-bolts (P/N 107-0171-611) and four 3/8"-16 zinc flanged lock nuts (P/N 312-1001-164).
2. Tighten the nuts to ensure the sensor is mounted securely.
3. Repeat the steps above to mount the remaining boom sensor(s).

Mount the Center Rack Sensor

FIGURE 8. Center Rack Sensor Mounting Location



1. Mount the center sensor (P/N 063-0130-018) to the machine's center rack boom tube support using two 1-9/16" W x 2-1/2" L x 3/8" thread U-bolts (P/N 107-0171-611) and four 3/8"-16 zinc flanged lock nuts (P/N 312-1001-164).
2. Tighten the nuts to ensure the sensor is mounted securely.

Connect the Sensor Cables

1. Connect left sensor cable (P/N 115-0171-527) to the connector on the outer left sensor.
2. Route the left sensor cable toward the AutoBoom valve.
3. Loop and tie-off any excess cable, allowing enough cable for boom folding and extension.
4. Repeat the steps above to connect the remaining sensor cable(s).

Note: *The sensor cables will be connected to the AutoBoom system in the wiring phase of installation.*

Install the Gauge Wheels - Optional

Gauge Wheel Mounting Locations

Wheel mounting locations may be influenced by the boom configuration. Determine the appropriate location for mounting the wheels on the boom, ensuring the wheels will not interfere with or be damaged while folding or unfolding the booms.

	<div style="background-color: #e67e22; color: white; padding: 5px; text-align: center;"> ⚠ WARNING </div> <p>The machine must remain stationary and switched off, with the booms unfolded and supported, while installation or maintenance is conducted.</p>
---	---

Mount the Gauge Wheels

Note: *The appearance of the wheel axles may vary.*

FIGURE 9. Gauge Wheel Installed



1. Remove the nuts from the wheel axle (P/N 063-0131-566).
2. Place the wheel (P/N 322-0131-008) on the wheel axle.
3. Reinstall the lug nuts on the wheel axle to secure the wheel.
4. Mount the receiver bracket (P/N 116-0159-537) to the front of the right boom inside the first fold joint using two 3-1/16" W x 4" L x 3/8" thread U-bolts (P/N 107-0171-608) and four 3/8"-16 zinc flanged lock nuts (P/N 312-1001-164).
5. Insert the wheel axle into the receiver bracket, positioning it so that the bottom of the wheel touches the ground (or nearly so) and the wheel faces away from the machine.
6. Secure the gauge wheel assembly in the wheel mounting bracket by installing two 1/2"-13 x 1-1/2" SS hex bolts (P/N 311-0058-186) and two 1/2"-13 zinc hex nuts (P/N 312-1001-043).
7. Repeat the steps above to install the left wheel.

Install the UltraGlide Wiring

Wiring Connections

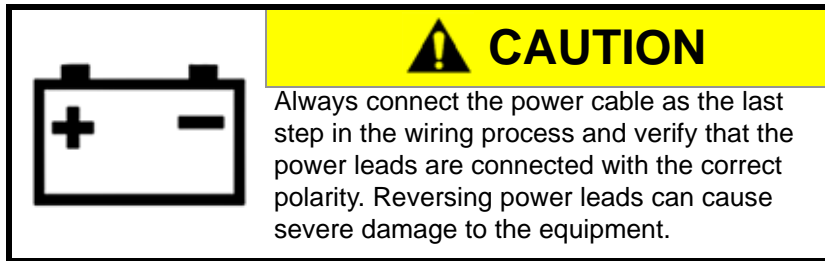

Note: For wiring connections made outside the cab, apply dielectric silicone grease (P/N 222-0000-006) generously on both the male and female ends of the connectors. Application of the grease will prevent corrosion to the pins and wires.

Install the AutoBoom Node

1. Mount the AutoBoom node (P/N 063-0130-013) to the valve mounting plate (P/N 107-0171-802) next to the AutoBoom valve using three 3/8"-16 UNC x 1-1/4" zinc plated hex bolts (P/N 311-0054-106) and three 3/8"-16 zinc flanged lock nuts (P/N 312-1001-164).

Note: Position the node so that the cable connectors face down.

2. Insert the large, rectangular node connector on the harness cable (P/N 115-0230-045) into the left port of the AutoBoom valve.
3. Tighten the bolt on the node connector to secure the connection.

Connect the Harness to the Boom Function Controls

1. Locate the Left Press and Right Press connectors on the harness cable (P/N 115-0230-045).
2. Route the connectors to the AutoBoom valve (P/N 063-0131-126).
3. Connect the Left Press connector to Port G1 on the AutoBoom valve.
4. Connect the Right Press connector to Port G4 on the AutoBoom valve.
5. Locate the Left Solenoid and Right Solenoid connectors on the harness cable.
6. Connect the Left Solenoid connector to Port 4A on the AutoBoom valve.
7. Connect the Right Solenoid connector to Port 4B on the AutoBoom valve.
8. Locate the Left Prop and Right Prop connectors on the harness cable.
9. Connect the Left Prop connector to Port 5A on the AutoBoom valve.
10. Connect the Right Prop connector to Port 13A on the AutoBoom valve.

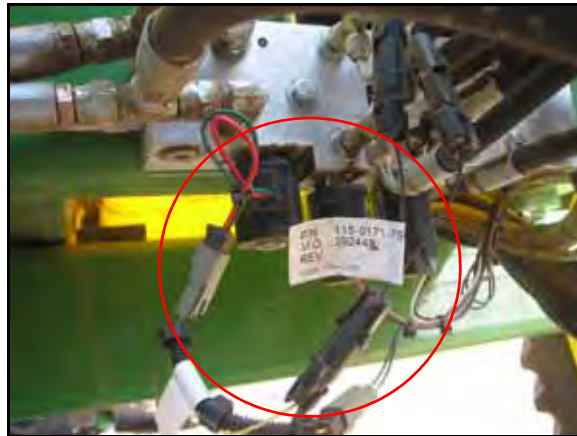
FIGURE 10. Directional Valve Boom Sense Adapter Cables Installed

11. Locate the machine's directional valve.
12. Disconnect the machine's directional valve connector from the directional valve.
13. Install a boom sense adapter cable (P/N 115-0171-558) on the machine's directional valve connector.
14. Install the single weatherpack boom sense adapter cable (P/N 115-0171-790) on the installed boom sense adapter cable.
15. Connect the Right Down and Left Down connectors on the AutoBoom harness cable (P/N 115-0230-045) to the connectors on the installed weatherpack boom sense adapter cable (P/N 115-0171-790).

FIGURE 11. Machine's Up Cylinder Wiring

16. Install boom sense adapter cables (P/N 115-0171-558) between the machine's cylinder up coils and the connectors.
17. Connect the cable connectors to the Right Up and Left Up connectors on the AutoBoom harness (P/N 115-0230-045) to the installed boom sense adapter cables.

Connect the Harness Cable to the Sensors

1. Locate the Center Sensor connector on the AutoBoom harness cable.
2. Connect the Center Sensor connector to the installed center sensor (P/N 063-0130-018).
3. Locate the Left Outer Sensor connector on the AutoBoom harness cable.
4. Connect the Left Outer Sensor connector to the installed left sensor cable (P/N 115-0171-527).
5. Locate the Right Outer Sensor connector on the AutoBoom harness cable.



6. Connect the Right Outer Sensor connector to the installed right sensor cable.
7. If optional inside boom sensor sensors are installed, repeat the steps above to connect the sensors.

Connect the Harness Cable to the Controller Cable

1. Route the harness cable (P/N 115-0230-045) toward the machine's cab.
2. Connect the harness cable to the controller cable (P/N 115-0230-007).
3. Tighten the connector cap to secure the connection.

Note: *Be sure to allow enough slack in the harness cable to allow for boom racking.*

Connect the Controller (If Applicable)

1. Route the controller cable (P/N 115-0230-007) into the right side of the machine's cab.
2. Locate the two controller connectors and connect them to the AutoBoom controller (P/N 063-0130-011).

Note: *The AutoBoom controller should be mounted in the machine's cab so that the operator has easy access to it.*

Connect the Field Computer (If Applicable)

Refer to the Installation & Operation Manual and the appropriate wiring schematic beginning on page 55 for installation and wiring instructions for your specific field computer.

Connect the Power Leads

1. Locate the power cable that has the red and white power leads at one end.
2. Disconnect the machine's connectors from the battery terminals.
3. Install the red power lead on the positive battery terminal and reinstall the machine's battery connector.
4. Install the white power lead on the negative battery terminal and reinstall the machine's battery connector.

SCS 4000/5000

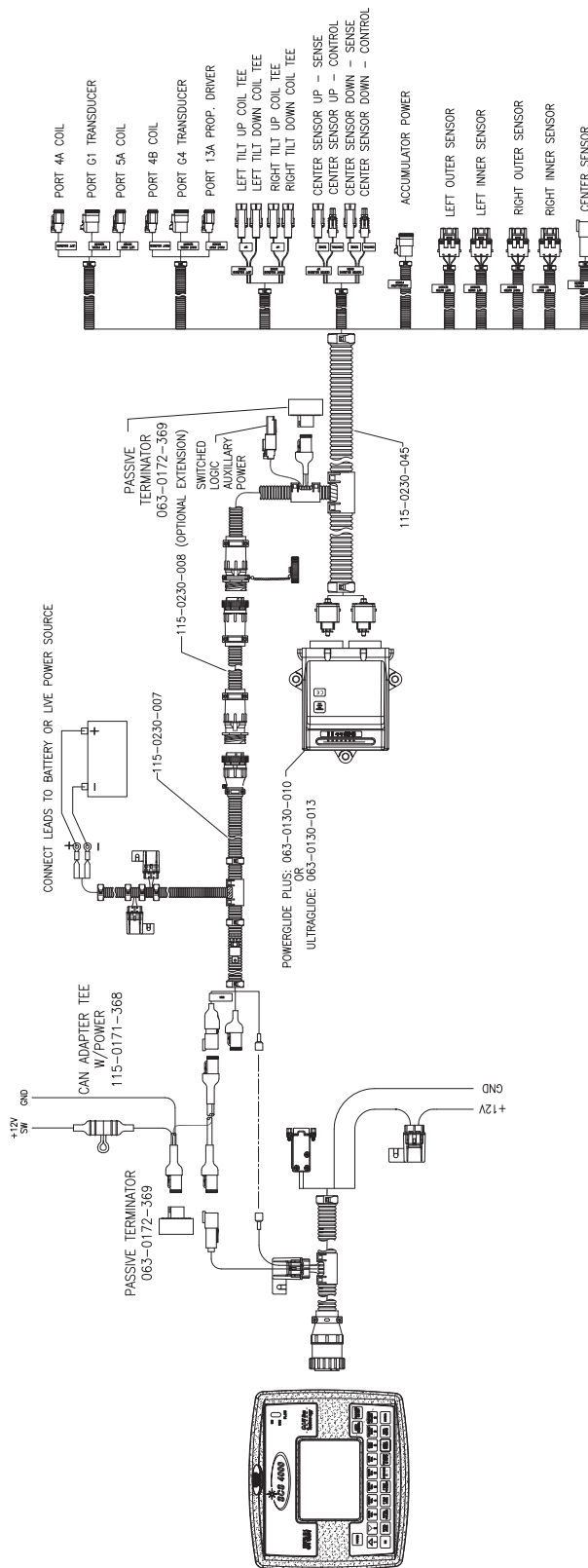

Viper Pro & Envizio Pro

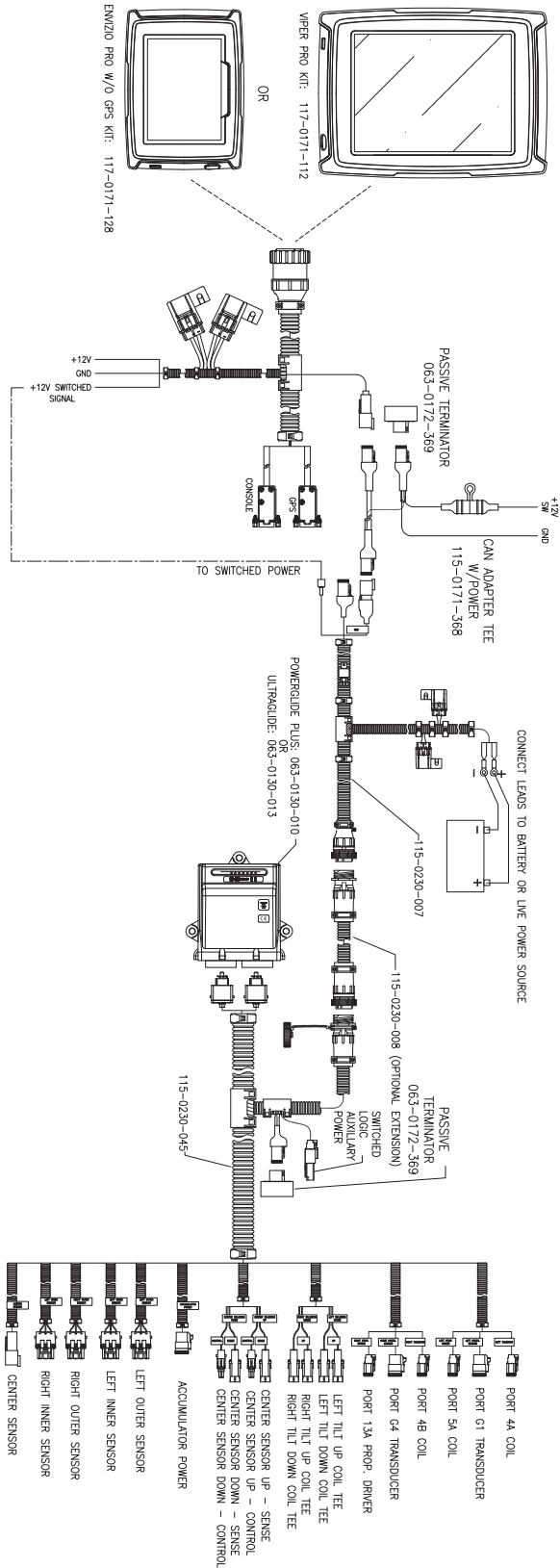

CHAPTER

6

Replacement Parts

This section contains replacement part diagrams for PowerGlide, PowerGlide Plus, and UltraGlide systems. Refer to these diagrams when calling to request replacement parts.

Valve Blocks

PowerGlide Valve Replacement Parts

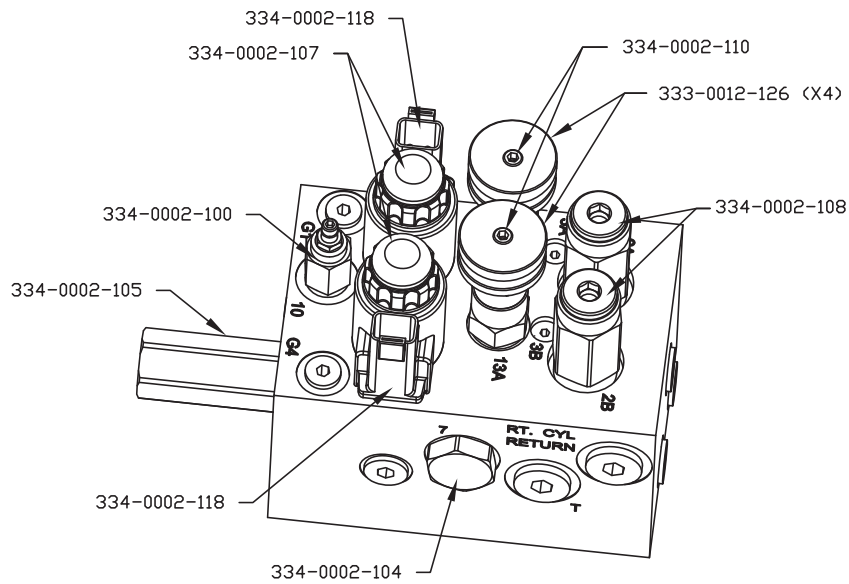

063-0131-127
VALVE, HYDRAULIC POWERGLIDE,
OPEN CENTER, AUTOBOOM

Sensors

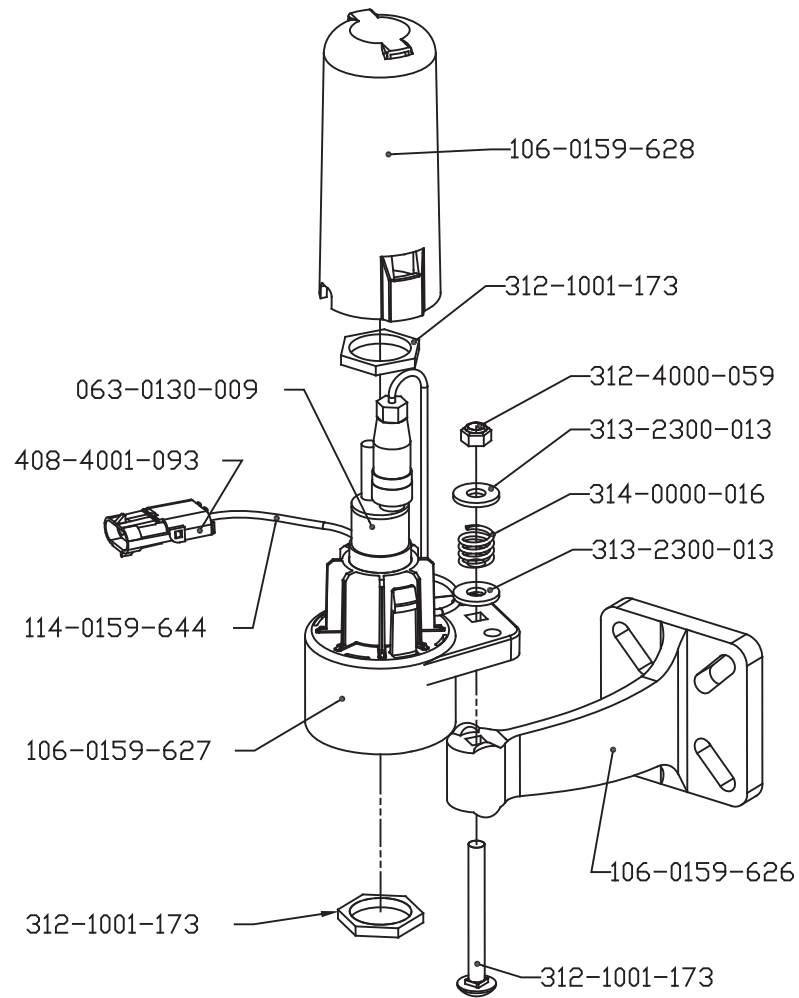

E

Electrical

Safety 2

H

Hydraulic

Fittings 4

Safety 2

I

Important Safety Information

Electrical 2

Hydraulics 2

K

Kit Contents

PowerGlide 5

PowerGlide Plus 19

UltraGlide 39

P

Point of Reference 4**PowerGlide 5**

Install

Gauge Wheels 14

Gauge Wheel Mounting Locations 14

Mounting the Gauge Wheels 14

Hydraulic System 8

Converting the Sprayer's Hydraulic Valve to
Open Center 9, 23, 44

Hydraulic Schematic 13

Installing Fittings on the AutoBoom Valve 9

Installing Left and Right Cylinder Hoses 12

Installing the Pressure and Tank Hoses 11

Mounting the AutoBoom Valve 10

Wiring 15

Connecting the Controller 16

Connecting the Harness to the Boom Func-
tion Controls 15Connecting the Harness to the Controller
Cable 15

Connecting the Power Leads 16

Wiring Connections 15

Wiring Schematic 17

Kit Contents 5

PowerGlide Plus 19

Install

Gauge Wheels 31

Gauge Wheel Mounting Locations 31

Mounting the Gauge Wheels 31

Hydraulic System 22

Installing Fittings on the AutoBoom Valve 26

Installing the Left and Right Cylinder
Hoses 28

Installing the Pressure and Tank Hoses 27

Mounting the AutoBoom Valve 26

Removing the Orifice Fittings 23

Wiring Schematic 30

Wiring 32

Connecting the Controller 34

Connecting the Field Computer 34

Connecting the Harness Cable to the Control-
ler Cable 33Connecting the Harness to the Boom Func-
tion Controls 32

Connecting the Power Leads 34

Installing the AutoBoom Node 32

Wiring Connections 32

Wiring Schematics 35

AutoBoom Controller 35

Envizio Plus 36

SCS 4000/5000 37

Viper Pro & Envizio Pro 38

Kit Contents 19

Preparing for Installation 4

R

Recommendations 4**Replacement Parts**

Sensors 61

Valve Blocks 59

PowerGlide 59

PowerGlide Plus and UltraGlide 60

Wheels 60

T

Tools Needed 4

U

UltraGlide 39

Install

Gauge Wheels

Gauge Wheel Mounting Locations 51

Mounting the Gauge Wheels 51

Gauge Wheels - Optional 51

Hydraulic System 43

Hydraulic Schematic 48

Installing Fittings on the AutoBoom Valve 44

Installing the Left and Right Cylinder
Hoses 47

Installing the Pressure and Tank Hoses 46

Mounting the AutoBoom Valve 45

Sensors 49

Boom Sensor Mounting Locations 49

Mounting the Boom Sensors 49

Mounting the Center Rack Sensor 49

Wiring

Connecting the Harness Cable to the
Sensors 53

Wiring 52

Connecting the Controller 54

Connecting the Field Computer 54

Connecting the Harness Cable to the Control-
ler Cable 54Connecting the Harness to the Boom Func-
tion Controls 52

Connecting the Power Leads 54

Installing the AutoBoom Node	52
Wiring Connections	52
Wiring Schematics	55
AutoBoom Controller	55
Envizio Plus	56
SCS 4000/5000	57
Viper Pro & Envizio Pro	58
Kit Contents	39

RAVEN

RAVEN INDUSTRIES

Limited Warranty

What Does this Warranty Cover?

This warranty covers all defects in workmanship or materials in your Raven Applied Technology Product under normal use, maintenance, and service.

How Long is the Coverage Period?

Raven Applied Technology Products are covered by this warranty for 12 months after the date of purchase. This warranty coverage applies only to the original owner and is nontransferable.

How Can I Get Service?

Bring the defective part and proof of purchase to your Raven Dealer. If your Dealer agrees with the warranty claim, the Dealer will send the part and proof of purchase to their distributor or to Raven Industries for final approval.

What Will Raven Industries Do?

Upon confirmation of the warranty claim, Raven Industries will, at our discretion, repair or replace the defective part and pay for return freight.

What is not Covered by this Warranty?

Raven Industries will not assume any expense or liability for repairs made outside our facilities without written consent. Raven Industries is not responsible for damage to any associated equipment or products and will not be liable for loss of profit or other special damages. The obligation of this warranty is in lieu of all other warranties, expressed or implied, and no person or organization is authorized to assume any liability for Raven Industries.

Damages caused by normal wear and tear, misuse, abuse, neglect, accident, or improper installation and maintenance are not covered by this warranty.

R A V E N

Redball 690
AutoBoom™ Installation Manual
(P/N 016-0230-066 Rev D 11/09)

Simply improving your position.™



Raven Industries
Applied Technology Division
P.O. Box 5107
Sioux Falls, SD 57117-5107

Toll Free (U.S. and Canada): (800)-243-5435
or Outside the U.S. :1 605-575-0722
Fax: 605-331-0426
www.ravenprecision.com
atdinfo@ravenind.com

Notice: This document and the information provided are the property of Raven Industries, Inc. and may only be used as authorized by Raven Industries, Inc. All rights reserved under copyright laws.