

Fast 9600 - 80'-120' Booms AutoBoom Installation Manual

Manual No. 016-0230-096 02/17

E289115

Disclaimer

While every effort has been made to ensure the accuracy of this document, Raven Industries assumes no responsibility for omissions and errors. Nor is any liability assumed for damages resulting from the use of information contained herein.

Raven Industries shall not be responsible or liable for incidental or consequential damages or a loss of anticipated benefits or profits, work stoppage or loss, or impairment of data arising out of the use, or inability to use, this system or any of its components. Raven Industries shall not be held responsible for any modifications or repairs made outside our facilities, nor damages resulting from inadequate maintenance of this system.

As with all wireless and satellite signals, several factors may affect the availability and accuracy of wireless and satellite navigation and correction services (e.g. GPS, GNSS, SBAS, etc.). Therefore, Raven Industries cannot guarantee the accuracy, integrity, continuity, or availability of these services and cannot guarantee the ability to use Raven systems, or products used as components of systems, which rely upon the reception of these signals or availability of these services. Raven Industries accepts no responsibility for the use of any of these signals or services for other than the stated purpose.

Chapter 1	<i>Important Safety Information</i>	1
Hydraulic Safety		2
Instructions for Wire Routing		2
Instructions for Hose Routing		3
Chapter 2	<i>Introduction</i>	5
Introduction		5
Preparing for Installation		5
Recommendations		6
Point of Reference		6
Hydraulic Fittings		6
Chapter 3	<i>PowerGlide</i>	9
PowerGlide Kit Contents		9
Install the PowerGlide Hydraulic System		12
Convert the Sprayer's Hydraulic Valve to Open Center (If Applicable)		12
Install Fittings on the AutoBoom Valve		13
Mount the AutoBoom Valve		14
Install the Pressure and Tank Hoses		14
Install the Left and Right Cylinder Hoses		16
PowerGlide Hydraulic Schematic		18
Install the Gauge Wheels		19
Gauge Wheel Mounting Locations		19
Mount the Gauge Wheels		19
Install the PowerGlide Wiring		20
Connect the Harness to the Boom Function Controls		20
Connect the Harness Cable to the Controller Cable		20
Connect the Controller		21
Connect the Power Leads		21
PowerGlide Wiring Schematic		22
AutoBoom Controller		22
Chapter 4	<i>PowerGlide Plus</i>	23
PowerGlide Plus Kit Contents		23
Install the PowerGlide Plus Hydraulic System		27
Convert the Sprayer's Hydraulic Valve to Open Center (If Applicable)		27
Remove the Orifice Fittings		28
Install Fittings on the AutoBoom Valve		30
Mount the AutoBoom Valve		31
Install the Left and Right Cylinder Hoses		34
PowerGlide Plus Hydraulic Schematic		35
Install the Gauge Wheels		36

Gauge Wheel Mounting Locations	36
Mount the Gauge Wheels	36
Install the PowerGlide Plus Wiring	37
Install the AutoBoom Node	37
Connect the Harness to the Boom Function Controls	37
Connect the Harness Cable to the Implement Extension Tee - Gen II Cable Only	39
Connect the Harness Cable to the Controller Cable - Gen I Cable Only	39
Connect the Controller (If Applicable) - Gen I Cable Only	39
Connect the Field Computer (If Applicable)	39
Connect the Power Leads	39
PowerGlide Plus Wiring Schematic	40
Gen I Cabling	40
Gen II Cabling	41

Chapter 5 *UltraGlide* 43

UltraGlide Kit Contents	43
Install the UltraGlide Hydraulic System	48
Convert the Sprayer's Hydraulic Valve to Open Center (If Applicable)	49
Install Fittings on the AutoBoom Valve	49
Mount the AutoBoom Valve	50
Install the Left and Right Cylinder Hoses	52
UltraGlide Hydraulic Schematic	54
Install the UltraGlide Sensors	55
Boom Sensor Mounting Locations	55
Mount the Center Rack Sensor	56
Connect the Sensor Cables	56
Install the Gauge Wheels - Optional	56
Gauge Wheel Mounting Locations	56
Mount the Gauge Wheels	57
Install the UltraGlide Wiring	58
Install the AutoBoom Node	58
Connect the Harness to the Boom Function Controls	58
Install the Center Rack Control	60
Connect the Harness Cable to the Sensors	61
Connect the Harness Cable to the Implement Extension Tee - Gen II Cable Only	61
Connect the Harness Cable to the Controller Cable - Gen I Cable Only	61
Connect the Controller (If Applicable) - Gen I Cable Only	61
Connect the Field Computer (If Applicable)	61
Connect the Power Leads	61
UltraGlide Wiring Schematic	63
Gen I Cabling	63
Gen II Cabling	64

Chapter 6	<i>Replacement Parts</i>	65
Valve Blocks		66
PowerGlide Valve Replacement Parts		66
PowerGlide Plus and UltraGlide Valve Replacement Parts		67
Wheels		67
Sensors		68

CHAPTER

1

IMPORTANT SAFETY INFORMATION

NOTICE

Read this manual and the operation and safety instructions included with your implement and/or controller carefully before installing the AutoBoom™ system.

- Follow all safety information presented within this manual.
- If you require assistance with any portion of the installation or service of your Raven equipment, contact your local Raven dealer for support.
- Follow all safety labels affixed to the AutoBoom system components. Be sure to keep safety labels in good condition and replace any missing or damaged labels. To obtain replacements for missing or damaged safety labels, contact your local Raven dealer.

When operating the machine after installing AutoBoom, observe the following safety measures:

- Be alert and aware of surroundings.
- Do not operate AutoBoom or any agricultural equipment while under the influence of alcohol or an illegal substance.
- Remain in the operator's position in the machine at all times when AutoBoom is engaged.
- Disable AutoBoom when exiting from the operator's seat and machine.
- Do not drive the machine with AutoBoom enabled on any public road.
- Determine and remain a safe working distance from other individuals. The operator is responsible for disabling AutoBoom when the safe working distance has diminished.
- Ensure AutoBoom is disabled prior to starting any maintenance work on AutoBoom or the machine.

WARNING

- When starting the machine for the first time after installing AutoBoom, be sure that all persons stand clear, in case a hose has not been properly tightened.
- The machine must remain stationary and switched off, with the booms unfolded and supported, during installation or maintenance.

CAUTION

HYDRAULIC SAFETY

- Raven Industries recommends that appropriate protective equipment be worn at all times when working on the hydraulic system.
- Never attempt to open or work on a hydraulic system with the equipment running. Care should always be taken when opening a system that has been previously pressurized.
- When disconnecting the hydraulic hoses or purging is required, be aware that the hydraulic fluid may be extremely hot and under high pressure. Caution must be exercised.
- Any work performed on the hydraulic system must be done in accordance with the machine manufacturer's approved maintenance instructions.
- When installing AutoBoom hydraulics or performing diagnostics, maintenance, or routine service, ensure that precautions are taken to prevent any foreign material or contaminants from being introduced into the machine's hydraulic system. Objects or materials that are able to bypass the machine's hydraulic filtration system will reduce performance and possibly damage the AutoBoom hydraulic valve.

INSTRUCTIONS FOR WIRE ROUTING

The word "harness" is used to mean all electrical leads and cables, bundled and unbundled. When installing harness, secure it at least every 30 cm (12in) to the frame. Follow existing harness as much as possible and use these guidelines:

Harness should not contact or be attached to:

- Lines and hoses with high vibration forces or pressure spikes
- Lines and hoses carrying hot fluids beyond harness component specifications

Avoid contact with any sharp edge or abrading surfaces such as, but not limited to:

- Sheared or flame cut edges
- Edges of machined surfaces
- Fastener threads or cap screw heads
- Ends of adjustable hose clamps
- Wire exiting conduit without protection, either ends or side of conduit
- Hose and tube fittings

Routing should not allow harnesses to:

- Hang below the unit
- Have the potential to become damaged due to exposure to the exterior environment. (i.e. tree limbs, debris, attachments)
- Be placed in areas of or in contact with machine components which develop temperatures higher than the temperature rating of harness components
- Wiring should be protected or shielded if it needs to route near hot temperatures beyond harness component specifications

Harnessing should not have sharp bends

Allow sufficient clearance from machine component operational zones such as:

- Drive shafts, universal joints and hitches (i.e. 3-point hitch)
- Pulleys, gears, sprockets

- Deflection and backlash of belts and chains
- Adjustment zones of adjustable brackets
- Changes of position in steering and suspension systems
- Moving linkages, cylinders, articulation joints, attachments
- Ground engaging components

For harness sections that move during machine operation:

- Allow sufficient length for free movement without interference to prevent: pulling, pinching, catching or rubbing, especially in articulation and pivot points
- Clamp harnesses securely to force controlled movement to occur in the desired harness section
- Avoid sharp twisting or flexing of harnesses in short distances
- Connectors and splices should not be located in harness sections that move

Protect harnesses from:

- Foreign objects such as rocks that may fall or be thrown by the unit
- Buildup of dirt, mud, snow, ice, submersion in water and oil
- Tree limbs, brush and debris
- Damage where service personnel or operators might step or use as a grab bar
- Damage when passing through metal structures

IMPORTANT: Avoid directly spraying electrical components and connections with high pressure water. High pressure water sprays can penetrate seals and cause electrical components to corrode or otherwise become damaged. When performing maintenance:

- Inspect all electrical components and connections for damage or corrosion. Repair or replace components, connections, or cable as necessary.
- Ensure connections are clean, dry, and not damaged. Repair or replace components, connections, or cable as necessary.
- Clean components or connections using low pressure water, pressurized air, or an aerosol electrical component cleaning agent.
- Remove visible surface water from components, connections, or seals using pressurized air or an aerosol electrical component cleaning agent. allow components to dry completely before reconnecting cables.

INSTRUCTIONS FOR HOSE ROUTING

The word "hose" is used to mean all flexible fluid carrying components. Follow existing hoses as much as possible and use these guidelines:

Hoses should not contact or be attached to:

- Components with high vibration forces
- Components carrying hot fluids beyond component specifications

Avoid contact with any sharp edge or abrading surfaces such as, but not limited to:

- Sheared or flame cut edges
- Edges of machined surfaces
- Fastener threads or cap screw heads

- Ends of adjustable hose clamps

Routing should not allow hoses to:

- Hang below the unit
- Have the potential to become damaged due to exposure to the exterior environment. (i.e. tree limbs, debris, attachments)
- Be placed in areas of or in contact with machine components which develop temperatures higher than the temperature rating of hose components
- Hoses should be protected or shielded if it needs to route near hot temperatures beyond hose component specifications

Hoses should not have sharp bends

Allow sufficient clearance from machine component operational zones such as:

- Drive shafts, universal joints and hitches (i.e. 3-point hitch)
- Pulleys, gears, sprockets
- Deflection and backlash of belts and chains
- Adjustment zones of adjustable brackets
- Changes of position in steering and suspension systems
- Moving linkages, cylinders, articulation joints, attachments
- Ground engaging components

For hose sections that move during machine operation:

- Allow sufficient length for free movement without interference to prevent: pulling, pinching, catching or rubbing, especially in articulation and pivot points
- Clamp hoses securely to force controlled movement to occur in the desired hose section
- Avoid sharp twisting or flexing of hoses in short distances

Protect hoses from:

- Foreign objects such as rocks that may fall or be thrown by the unit
- Buildup of dirt, mud, snow, ice, submersion in water and oil
- Tree limbs, brush and debris
- Damage where service personnel or operators might step or use as a grab bar
- Damage when passing through metal structures
- High pressure wash

INTRODUCTION

Congratulations on your purchase of the Raven AutoBoom system! This system is designed to provide automated boom height adjustment for agricultural equipment.

This manual applies to the following machines. For future reference, write your serial number in the space below.

MAKE: Fast
MODEL: 9600 - 80'-100' Booms
YEAR:
SERIAL NUMBER:

FIGURE 1. Fast 9600



NOTE: This manual contains the installation instructions for the PowerGlide, PowerGlide Plus, and UltraGlide systems. Be sure to identify which system you have and follow only the instructions for that system.

PREPARING FOR INSTALLATION

Before installing AutoBoom, park the machine where the ground is level, clean, and dry. Leave the machine turned off for the duration of the installation process.

During the installation process, follow good safety practices. Be sure to carefully read the instructions in this manual as you complete the installation process.

RECOMMENDATIONS

Raven Industries recommends the following best practices before installing or operating the AutoBoom system for the first time, at the start of the season, or when moving the AutoBoom system to another machine:

- Ensure the machine's hydraulic filters have been recently changed and there are no issues with the machine's hydraulic system (e.g., pump issues, faulty hydraulic motors, fine metal deposits in the hydraulic hoses, etc.).
- Operate each of the machine's boom hydraulic functions (i.e., tilt, fold, center rack, tongue extension, or other hydraulic valve functions) three times to ensure the machine's hydraulic valve is using fresh oil and debris is flushed from the hydraulic hoses, valves, and filters.
- Upon installation of the AutoBoom system, operate the boom and center rack raise/lower functions through the machine's manual control functions first before operating them via the AutoBoom controller/field computer to ensure the hydraulic system has been installed correctly and air is released from the system.

Raven Industries recommends the following best practices when installing the AutoBoom system.

- Use part numbers to identify the parts.
- Do not remove the plastic wrap from a part until it is necessary for installation.
- Do not remove plastic caps from a part until it is necessary for installation.

Tools Needed

The following tools are recommended for installation of the AutoBoom system:

- SAE standard-sized wrenches
- Cable ties
- Set of tools

POINT OF REFERENCE

The instructions in this manual assume that you are standing behind the machine, looking toward the cab.

HYDRAULIC FITTINGS

This manual may reference the following types of hydraulic fittings:

- SAE O-ring fittings
- ORFS (O-Ring Face Seal) fittings
- JIC fittings

SAE O-ring fitting



ORFS fitting



JIC fitting (M)



POWERGLIDE KIT CONTENTS

This section contains a list of the components that are included in the PowerGlide AutoBoom kit. Before beginning the AutoBoom installation, compare the items in the AutoBoom kit with the components on this list. If you have questions about the kit, contact your Raven dealer.

NOTE: In addition to the following kit components, an axle kit is required for the operation of the PowerGlide AutoBoom system. For available kits and ordering information, contact your local Raven dealer.

TABLE 1. PowerGlide Installation Kit (P/N 117-0230-096)





Picture	Item Description	Part Number	Qty.
Not Pictured	Manual - Fast 9600 - 80'-100' Booms AutoBoom Installation	016-0230-096	1
	Valve - PowerGlide AutoBoom	016-0131-127	1
	Bracket - Fast Weldment Receiver	116-0159-537	2
	Wheel	322-0131-008	2
	Cable - Boom Sense Adapter	115-0171-546	2
	Cable - 12' Extension	115-0230-008	1

TABLE 1. PowerGlide Installation Kit (P/N 117-0230-096)

Picture	Item Description	Part Number	Qty.
	U-Bolt - 5-1/16" W x 6" L x 7/16" Thread	107-0171-603	4
	Bolt - 5/16"-18 x 1-1/4" Hex	311-0052-106	2
	Bolt - 5/16"-18 x 1-1/4" SS Hex	311-0058-186	4
	Nut - 1/2"-13 Zinc Hex	312-1001-043	4
	Nut - 7/16"-16 Zinc Flanged Lock	312-1001-165	8
	Washer - 5/16" Zinc Plated Lock	313-1000-019	2

TABLE 2. Hydraulic Kit (P/N 117-0134-096)





Picture	Item Description	Part Number	Qty.
	Fitting - 3/4" JIC M/M/F Swivel Run Tee Adapter	333-0012-039	1
	Fitting - 3/4" JIC M/F 45° Swivel Elbow	333-0012-040	1
	Fitting - 9/16" JIC M/M/F Swivel Run Tee Adapter	333-0012-043	2
	Fitting - 9/16 JIC (M) to 9/16" SAE O-Ring (M) Straight Adapter	333-0012-045	2

TABLE 2. Hydraulic Kit (P/N 117-0134-096)









Picture	Item Description	Part Number	Qty.
	Fitting - 3/4" SAE O-Ring (M) to 3/4" JIC (M) Straight Adapter	333-0012-093	4
	9/16" SAE O-Ring Internal Hex	333-0012-104	2
	Hydraulic Hose - 3/4" JIC (F) to 3/4" JIC (F) 90° - 24"	214-1000-609	2
	Hydraulic Hose - 9/16" JIC (F) to 9/16" JIC (F) 90° - 36"	214-1000-610	2

TABLE 3. PowerGlide Wiring Kit (P/N 117-0137-022)

Picture	Item Description	Part Number	Qty.
Not Pictured	AutoBoom PowerGlide Calibration Operator's Manual	016-0130-061	1
	AutoBoom PowerGlide Controller	063-0130-011	1
	Cable - AutoBoom Controller	115-0230-002	1
	Cable - Harness	115-0230-003	1

INSTALL THE POWERGLIDE HYDRAULIC SYSTEM

	<p style="text-align: center;">⚠ WARNING</p> <p>The machine must remain stationary and switched off, with the booms unfolded and supported, during installation or maintenance.</p>
---	--

	<p style="text-align: center;">⚠ CAUTION</p> <p>When installing AutoBoom hydraulics or performing diagnostics, maintenance, or routine service, ensure precautions are taken to prevent any foreign material from being introduced into the machine's hydraulic system.</p> <p>Objects or materials that are able to bypass the machine's hydraulic filtration system will reduce performance and possibly damage the AutoBoom hydraulic valve.</p>
---	--

	<p style="text-align: center;">NOTICE</p> <p>The appearance of the AutoBoom hydraulic valve may vary slightly from the images contained in this manual. However, the fittings, hose connections, and cable connections remain the same.</p>
---	--

CONVERT THE SPRAYER'S HYDRAULIC VALVE TO OPEN CENTER (IF APPLICABLE)

By factory default, the machine's main hydraulic valve is configured as a "closed center" hydraulic system. In order for AutoBoom to function properly and to prevent the hydraulic system from overheating, Raven recommends converting the machine's hydraulic system to an "open center" system.

NOTE: Contact your Fast dealer to obtain the open center conversion kit.

FIGURE 1. Converted Hydraulic Valve - Closed Center to Open Center

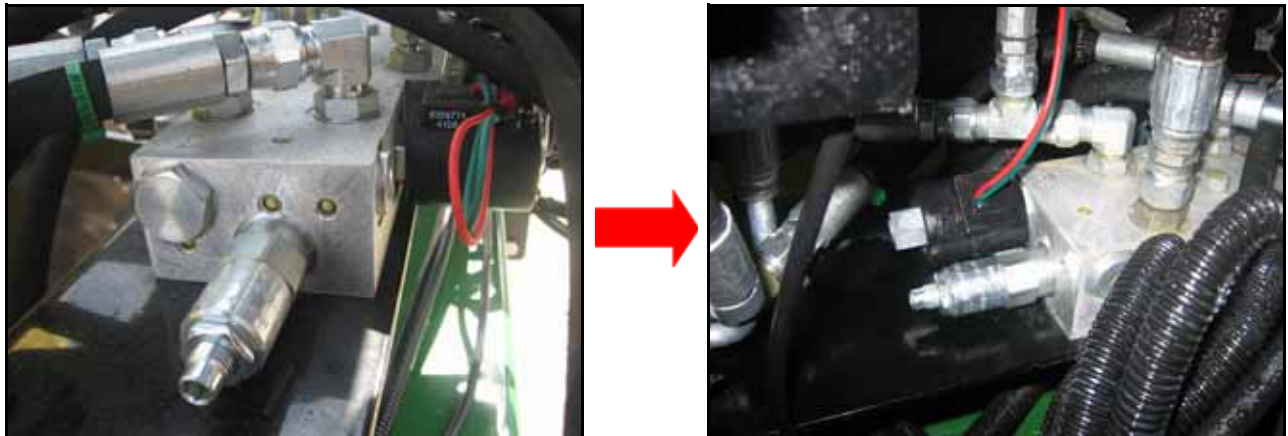

INSTALL FITTINGS ON THE AUTOBOOM VALVE

Before mounting the AutoBoom valve on the machine, install the proper fittings on the valve. This prepares the valve for installation and simplifies the hose connection process later in the procedure. Refer to the following table to install the fittings in the appropriate ports of the AutoBoom valve.

FIGURE 2. Fittings Installed on the AutoBoom Valve



Fitting	Part Number	Port
Fitting - 9/16" JIC (M) to 9/16" SAE O-Ring (M) Straight Adapter	333-0012-045	LC, RC
Fitting - 3/4" JIC (M) to 3/4" SAE O-Ring (M) Straight Adapter	333-0012-093	Left T, P, EF
Fitting - 3/4" JIC M/F 45° Swivel Elbow	333-0012-040	P
Fitting - 9/16" SAE O-Ring Internal Hex Plug	333-0012-104	LV, RV



MOUNT THE AUTOBOOM VALVE

FIGURE 3. AutoBoom Valve Mounting Location



1. Verify that the existing holes in the machine's center rack (to the left of the machine's hydraulic valve) align with the mounting holes in the AutoBoom valve. If they do not, drill two 5/16" holes in the mounting location the same distance apart as the holes in the AutoBoom valve.
2. Secure the AutoBoom valve (P/N 063-0131-127) to the machine's center rack using two 5/16"-18 x 1-1/4" hex bolts (P/N 311-0052-106) and two 5/16" zinc lock washers (P/N 313-1000-019).

INSTALL THE PRESSURE AND TANK HOSES

	<p style="text-align: center;">⚠ WARNING</p> <p>Hydraulics are under pressure. Care should always be taken with a system that has been pressurized. When disconnecting or purging hydraulic hoses, be aware that the hydraulic fluid within the machine's system may be extremely hot and under high pressure.</p>
--	---

	<p style="text-align: center;">⚠ CAUTION</p> <p>When installing AutoBoom hydraulics or performing diagnostics, maintenance, or routine service, ensure precautions are taken to prevent any foreign material from being introduced into the machine's hydraulic system.</p> <p>Objects or materials that are able to bypass the machine's hydraulic filtration system will reduce performance and possibly damage the AutoBoom hydraulic valve.</p>
--	--

FIGURE 4. Machine's Pressure Hose Removed and Fitting Installed

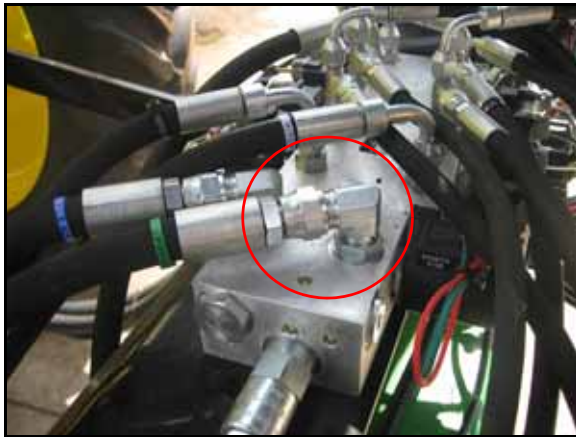

1. Disconnect the machine's pressure hose from the machine's hydraulic valve.
2. Remove the machine's existing elbow fitting from the pressure port of the machine's hydraulic valve.

FIGURE 5. Machine's Pressure Hose Installed on the AutoBoom Valve

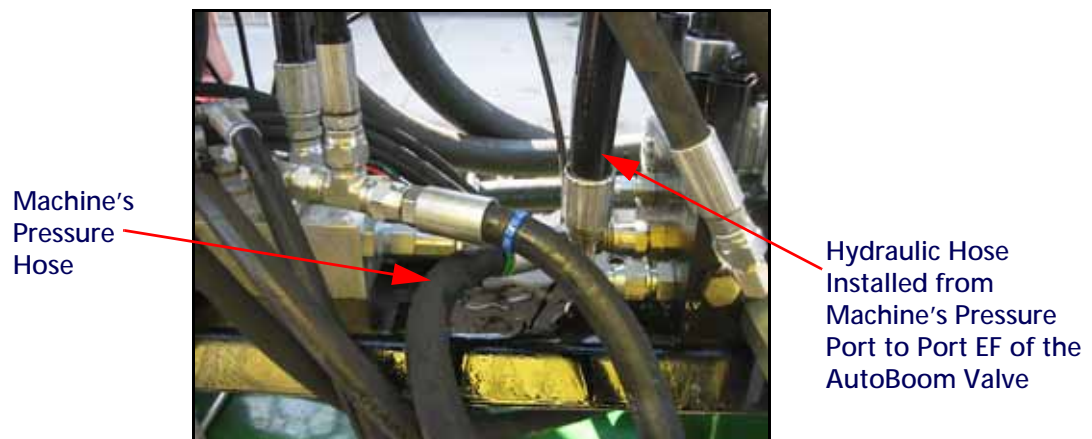

3. Connect the machine's pressure hose to the installed fittings in Port P of the AutoBoom valve.
4. Install a 3/4" SAE O-ring (M) to 3/4" JIC (M) straight adapter fitting (P/N 333-0012-093) in the pressure port of the machine's hydraulic valve.
5. Install the straight end of the supplied hydraulic hose (P/N 214-1000-609) on the installed fitting in the machine's pressure port.
6. Connect the 90° end of the installed hydraulic hose to the installed fitting in Port EF of the AutoBoom valve.

FIGURE 6. Tank (Return) Hose Installed



7. Disconnect the machine's return hose from the return port of the machine's hydraulic valve.
8. Install a 3/4" JIC M/M/F swivel run tee adapter fitting (P/N 333-0012-039) in the machine's return port.
9. Connect the machine's tank (return) hose to the opposite end of the installed tee fitting.
10. Install the straight end of the supplied hydraulic hose (P/N 214-1000-609) on the 90° end of the installed tee fitting.
11. Connect the 90° end of the installed hydraulic hose to the fittings installed in the Left T Port of the AutoBoom valve.

INSTALL THE LEFT AND RIGHT CYLINDER HOSES

FIGURE 7. Cylinder Hoses Installed

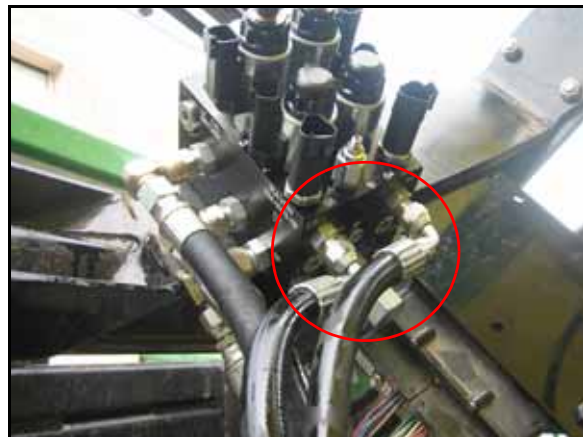
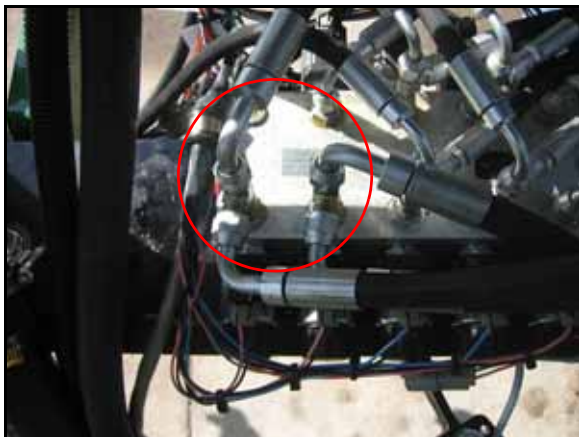

1. Disconnect the machine's cylinder up hoses from the left and right cylinder up ports of the machine's hydraulic valve.
2. Install 9/16" JIC M/M/F swivel run tee adapter fittings (P/N 333-0012-043) in the open ports on the machine's hydraulic valve.
3. Connect the machine's left cylinder hose to the opposite end of the installed tee fitting in the left cylinder up port of the machine's hydraulic valve.
4. Install the straight end of the supplied hydraulic hose (P/N 214-1000-610) on the 90° end of the installed tee fitting.
5. Connect the 90° end of the installed hydraulic hose to the fittings installed in Port LC of the AutoBoom valve.

6. Connect the machine's right cylinder hose to the opposite end of the installed tee fitting in the right cylinder up port of the machine's hydraulic valve.
7. Install the straight end of the supplied hydraulic hose (P/N 214-1000-610) on the 90° end of the installed tee fitting.
8. Connect the 90° end of the installed hydraulic hose to the fittings installed in Port RC of the AutoBoom valve.

POWERGLIDE HYDRAULIC SCHEMATIC

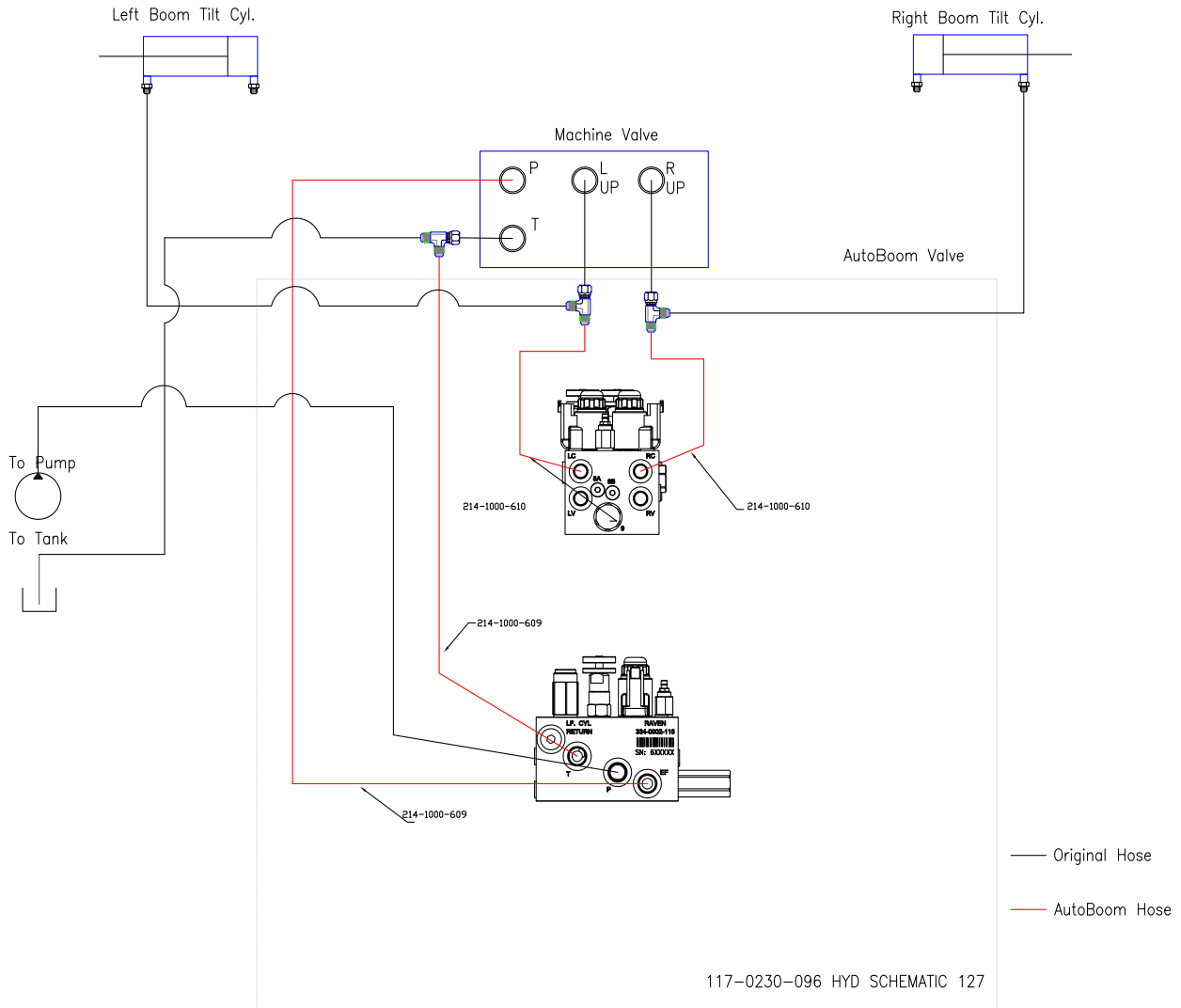

INSTALL THE GAUGE WHEELS

GAUGE WHEEL MOUNTING LOCATIONS

Wheel mounting locations may be influenced by the boom configuration. Determine the appropriate location for mounting the wheels on the boom, ensuring the wheels will not interfere with or be damaged while folding or unfolding the booms. The wheels should be mounted outside of the boom fold, but inside of the boom breakaway.

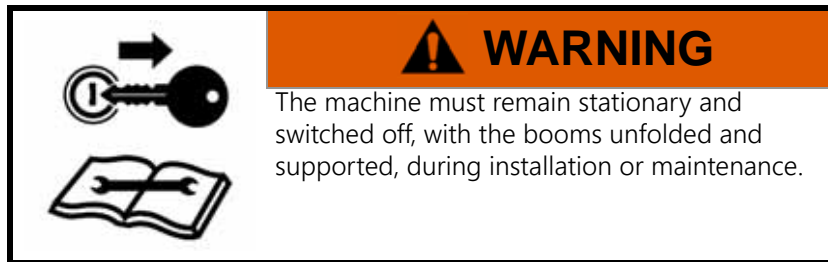

MOUNT THE GAUGE WHEELS

NOTE: The appearance of the wheel axles may vary, depending on the type of wheel axle kit that was ordered.

FIGURE 8. Gauge Wheel Installed



1. Remove the lug nuts from the wheel axle.
2. Place the wheel (P/N 322-0131-008) on the wheel axle.
3. Reinstall the lug nuts on the wheel axle to secure the wheel.
4. Mount the receiver bracket (P/N 116-0159-537) to the front of the left boom over the fold cylinder guide tube using two 5-1/16" W x 6" L x 7/16" thread U-bolts (P/N 107-0171-603) and four 7/16"-16 zinc flanged lock nuts (P/N 312-1001-165).
5. Insert the wheel axle into the receiver bracket, positioning it so that the bottom of the wheel touches the ground (or nearly so) and the wheel faces away from the machine.
6. Secure the gauge wheel assembly in the wheel mounting bracket by installing two 1/2"-13 x 1-1/2" SS hex bolts (P/N 311-0058-186) and two 1/2"-13 zinc hex nuts (P/N 312-1001-043).
7. Repeat the steps above to install the right wheel.

INSTALL THE POWERGLIDE WIRING

Wiring Connections

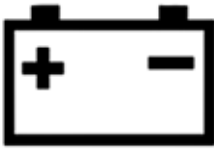
	<p style="text-align: center;">⚠ CAUTION</p> <p>Always connect the power cable as the last step in the wiring process and verify that the power leads are connected with the correct polarity. Reversing power leads can cause severe damage to the equipment.</p>
---	---

For wiring connections made outside the cab, apply dielectric silicone grease (P/N 222-0000-006) generously on both the male and female ends of the connectors. Application of the grease will prevent corrosion to the pins and wires.

CONNECT THE HARNESS TO THE BOOM FUNCTION CONTROLS

1. On the AutoBoom harness cable (P/N 115-0230-003), locate the Left Solenoid connector and connect it to Port 4A on the AutoBoom valve.
2. Connect the Right Solenoid connector to Port 4B on the AutoBoom valve.

FIGURE 9. Machine's Cylinder Up Wiring

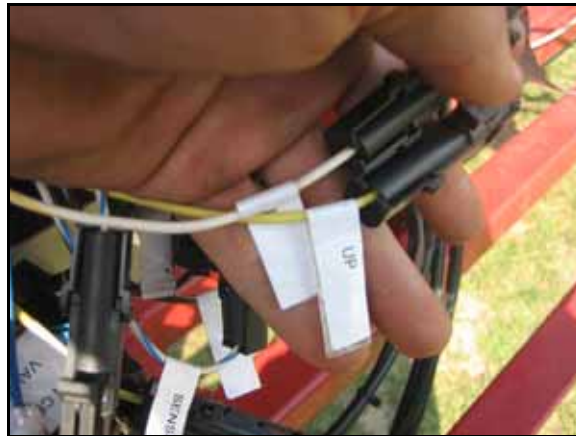

3. Install a boom sense adapter cable (P/N 115-0171-546) between the machine's left cylinder up coil and the connector.
4. Connect the boom sense adapter cable Up connector to the Left Up connector on the AutoBoom harness cable (P/N 115-0230-003).
5. Install a boom sense adapter cable (P/N 115-0171-546) between the machine's right cylinder up coil and the connector.
6. Connect the boom sense adapter cable Up connector to the Right Up connector on the AutoBoom harness cable.

NOTE: The system will now disengage when Up is pressed on the machine's controller. The system must be engaged via the AutoBoom controller or field computer screen.

CONNECT THE HARNESS CABLE TO THE CONTROLLER CABLE

1. Route the harness cable (P/N 115-0230-003) toward the machine's cab.

2. Connect the harness cable to the controller cable (P/N 115-0230-002).
3. Tighten the connector cap to secure the connection.

NOTE: Be sure to allow enough slack in the harness cable to allow for boom racking. If the harness cable is not long enough, it may be necessary to connect the 12' extension cable (P/N 115-0230-008) between the harness and controller cables.

CONNECT THE CONTROLLER

FIGURE 10. Controller Connectors



1. Route the controller cable (P/N 115-0230-002) into the right side of the machine's cab.
2. Locate the two controller connectors and connect them to the AutoBoom controller (P/N 063-0130-011).

NOTE: The AutoBoom controller should be mounted in the machine's cab so that the machine operator has easy access to it.

CONNECT THE POWER LEADS

1. Locate the power cable that has the power and ground leads at one end.
2. Disconnect the machine's connectors from the battery terminals.
3. Install the power lead on the positive battery terminal and reinstall the machine's battery connector.
4. Install the ground lead on the negative battery terminal and reinstall the machine's battery connector.

POWERGLIDE WIRING SCHEMATIC

AUTOBOOM CONTROLLER

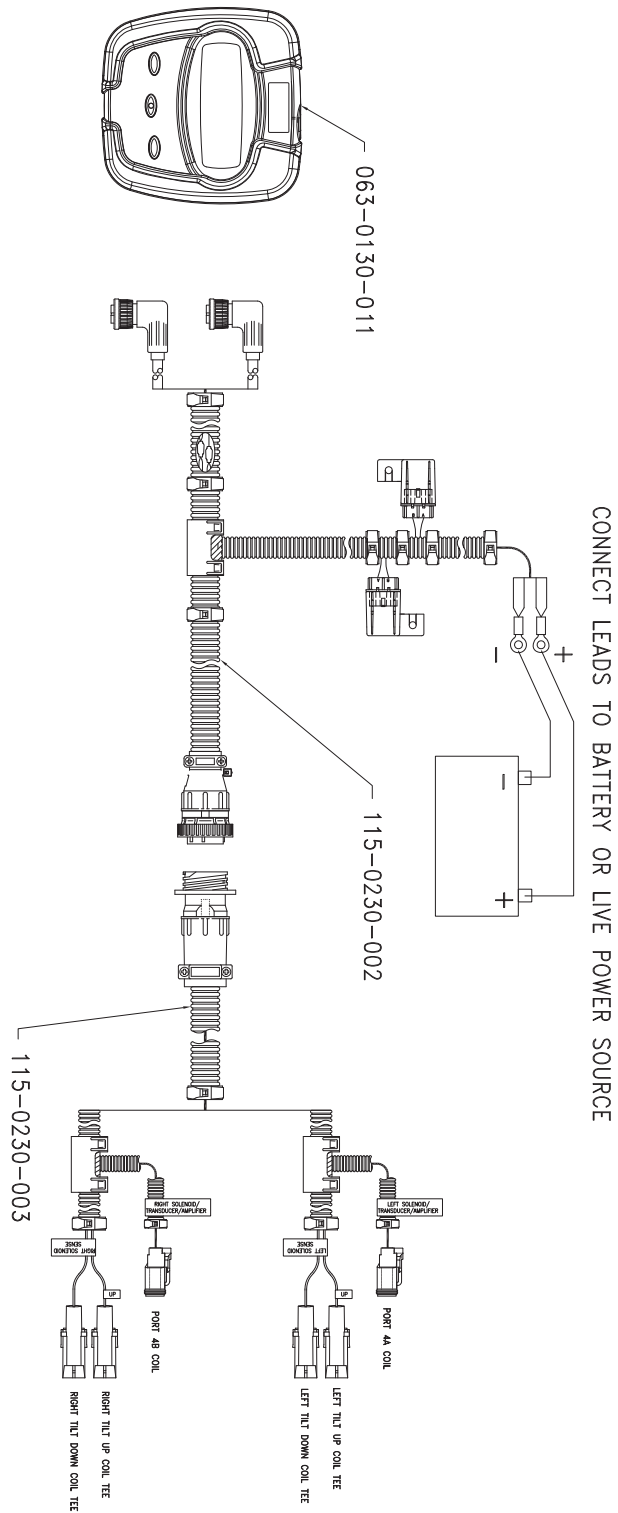

POWERGLIDE PLUS KIT CONTENTS

This section contains a list of the components that are included in the PowerGlide Plus AutoBoom kit. Before beginning the AutoBoom installation, compare the items in the AutoBoom kit with the components on this list. If you have questions about the kit, contact your Raven dealer.

TABLE 1. PowerGlide Plus Installation Kit (P/N 117-0231-096)

Picture	Item Description	Part Number	Qty.
Not Pictured	Manual - Fast 9600 - 80'-100' Booms AutoBoom Installation	016-0230-096	1
	Valve - PowerGlide Plus AutoBoom	063-0131-126	1
	Plate - Hydraulic Block Mounting	107-0171-619	1
	Cable - Boom Sense Adapter	115-0171-546	3
	Cable - Single Weatherpack Boom Sense Adapter	115-0171-790	1
	Cable - 12' Extension	115-0230-008	1
	Bolt - 5/16" -18 x 1-1/4" Hex	311-0052-106	2

TABLE 1. PowerGlide Plus Installation Kit (P/N 117-0231-096)



Picture	Item Description	Part Number	Qty.
	Bolt - 3/8"-16 x 1-1/4" Zinc Hex	311-0054-106	5
	Nut - 3/8"-16 Zinc Flanged Lock	312-1001-164	5
	Washer - 5/16" Zinc Plated Lock	313-1000-019	2

TABLE 2. Hydraulic Kit (P/N 117-0134-096)

Picture	Item Description	Part Number	Qty.
	Fitting - 3/4" JIC M/M/F Swivel Run Tee Adapter	333-0012-039	1
	Fitting - 3/4" JIC M/F 45° Swivel Elbow	333-0012-040	1
	Fitting - 9/16" JIC M/M/F Swivel Run Tee Adapter	333-0012-043	2
	Fitting - 9/16" JIC (M) to 9/16" SAE O-Ring (M) Straight Adapter	333-0012-045	2
	Fitting - 3/4" SAE O-Ring (M) to 3/4" JIC (M) Straight Adapter	333-0012-093	4
	9/16" SAE O-Ring Internal Hex	333-0012-104	2

TABLE 2. Hydraulic Kit (P/N 117-0134-096)



Picture	Item Description	Part Number	Qty.
	Hydraulic Hose - 3/4" JIC (F) to 3/4" JIC (F) 90° - 24"	214-1000-609	2
	Hydraulic Hose - 9/16" JIC (F) to 9/16" JIC (F) (F) 90° - 36"	214-1000-610	2

TABLE 3. PowerGlide Plus Wheel Kit (P/N 117-0133-023)







Picture	Item Description	Part Number	Qty.
	Axle Assembly - Right Cushioned AutoBoom	063-0131-585	1
	Axle Assembly - Left Cushioned AutoBoom	063-0131-590	1
	Bracket - Fast Weldment Receiver	116-0159-537	2
	Bracket - Hub Retainer	107-0171-617	2
	Wheel	322-0131-008	2
	U-Bolt - 5-1/16" W x 6" L x 7/16" Thread	107-0171-603	4
	Bolt - 1/2"-13 x 1-1/2" SS Hex	311-0058-186	4

TABLE 3. PowerGlide Plus Wheel Kit (P/N 117-0133-023)

Picture	Item Description	Part Number	Qty.
	Nut - 1/2"-13 Zinc Hex	312-1001-043	4
	Nut - 7/16"-16 Zinc Flanged Lock	312-1001-165	8

TABLE 4. Gen I PowerGlide Plus Wiring Kit (P/N 117-0137-023)







Picture	Item Description	Part Number	Qty.
Not Pictured	Manual - AutoBoom Calibration & Operation	016-0130-062	1
	Node - PowerGlide Plus AutoBoom	063-0130-010	1
	Cable - Harness	115-0230-045	1
	Cable - Power/CAN	115-0230-007	1

TABLE 5. Gen II PowerGlide Plus Wiring Kit (P/N 117-5130-001)

Picture	Item Description	Part Number	Qty.
Not Pictured	Manual - AutoBoom Calibration & Operation	016-0130-062	1
	Node - PowerGlide Plus AutoBoom	063-0130-010	1
	Cable - PowerGlide Plus/UltraGlide with CAN/Power Tee AutoBoom	115-0230-085	1

INSTALL THE POWERGLIDE PLUS HYDRAULIC SYSTEM

	<p style="text-align: center;">⚠ WARNING</p> <p>The machine must remain stationary and switched off, with the booms unfolded and supported, during installation or maintenance.</p>
---	--

	<p style="text-align: center;">⚠ CAUTION</p> <p>When installing AutoBoom hydraulics or performing diagnostics, maintenance, or routine service, ensure precautions are taken to prevent any foreign material from being introduced into the machine's hydraulic system.</p> <p>Objects or materials that are able to bypass the machine's hydraulic filtration system will reduce performance and possibly damage the AutoBoom hydraulic valve.</p>
---	--

	<p style="text-align: center;">NOTICE</p> <p>The appearance of the AutoBoom hydraulic valve may vary slightly from the images contained in this manual. However, the fittings, hose connections, and cable connections remain the same.</p>
---	--

CONVERT THE SPRAYER'S HYDRAULIC VALVE TO OPEN CENTER (IF APPLICABLE)

By factory default, the machine's main hydraulic valve is configured as a "closed center" hydraulic system. In order for AutoBoom to function properly and to prevent the hydraulic system from overheating, Raven recommends converting the machine's hydraulic system to an "open center" system.

NOTE: Contact your Fast dealer to obtain the open center conversion kit.

FIGURE 1. Converted Hydraulic Valve - Closed Center to Open Center

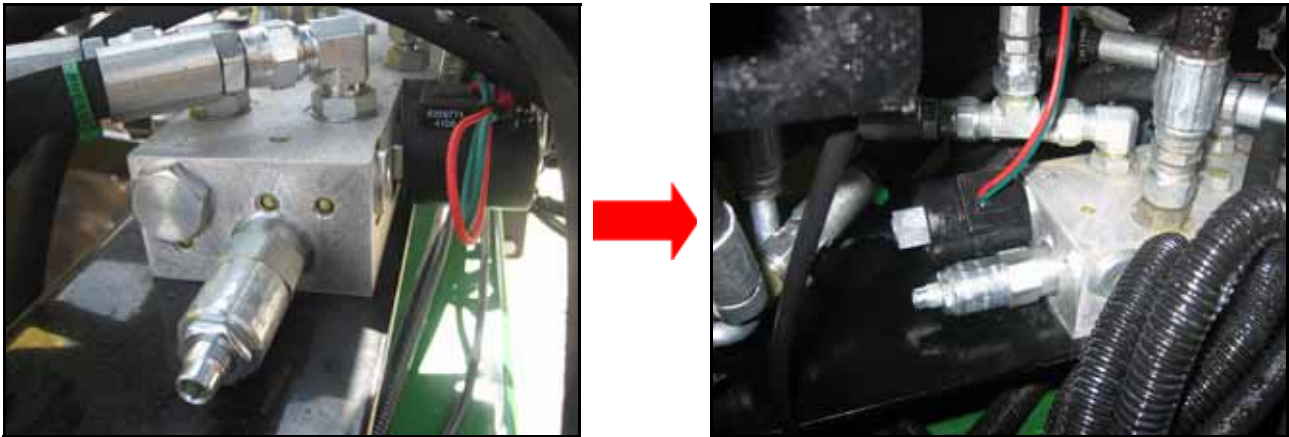

REMOVE THE ORIFICE FITTINGS

Before populating the hydraulic fittings on the AutoBoom valve, it is necessary to remove orifice fittings from the valve in the PowerGlide Plus system. Failure to remove these fittings from the valve will restrict the down speed of the booms when the system is enabled.

FIGURE 2. Port 3A and 3B Location



1. Locate Ports 3A and 3B on the AutoBoom valve (P/N 063-0131-126).

FIGURE 3. Coil Removed from the AutoBoom Valve



2. Remove the coils from the solenoids near Ports 3A and 3B to gain easy access to those ports.

FIGURE 4. Port Plugs Removed from the AutoBoom Valve



3. Use an Allen wrench to remove the plugs from Ports 3A and 3B.

FIGURE 5. Orifice Fitting Removed from the AutoBoom Valve



Orifice Fitting
Removed - Keep
for Future Use

4. Remove the orifice fittings from Ports 3A and 3B.

IMPORTANT: Tip the AutoBoom valve on its side and use the Allen wrench to remove the orifice from the cavity, taking care not to let the fitting fall into the valve.

FIGURE 6. Port Plug Reinstalled on the AutoBoom Valve



5. Use the Allen wrench to reinstall the port plugs on Ports 3A and 3B of the AutoBoom valve.

FIGURE 7. Coil Reinstalled on the AutoBoom Valve



6. Reinstall the coils on the solenoids of the AutoBoom valve.

INSTALL FITTINGS ON THE AUTOBOOM VALVE

Before mounting the AutoBoom valve on the machine, install the proper fittings on the valve. This prepares the valve for installation and simplifies the hose connection process later in the procedure. Refer to the following table to install the fittings in the appropriate ports of the AutoBoom valve.

FIGURE 8. Fittings Installed on the AutoBoom Valve



Fitting	Part Number	Port
Fitting - 9/16" JIC (M) to 9/16" SAE O-Ring (M) Straight Adapter	333-0012-045	LC, RC
Fitting - 3/4" JIC (M) to 3/4" SAE O-Ring (M) Straight Adapter	333-0012-093	Left T, P, EF
Fitting - 3/4" JIC M/F 45° Swivel Elbow	333-0012-040	P
Fitting - 9/16" SAE O-Ring Internal Hex Plug	333-0012-104	LV, RV

MOUNT THE AUTOBOOM VALVE

FIGURE 9. AutoBoom Valve Mounting Location



1. Verify that the existing holes in the machine's center rack (to the left of the machine's hydraulic valve) align with the mounting holes in the AutoBoom valve. If they do not, drill two 5/16" holes in the mounting location the same distance apart as the holes in the AutoBoom valve.
2. Secure the AutoBoom valve (P/N 063-0131-126) to the machine's center rack using two 5/16"-18 x 1-1/4" hex bolts (P/N 311-0052-106) and two 5/16" zinc lock washers (P/N 313-1000-019).

Install the Pressure and Tank Hoses

	<p style="text-align: center;">⚠ WARNING</p> <p>Hydraulics are under pressure. Care should always be taken with a system that has been pressurized. When disconnecting or purging hydraulic hoses, be aware that the hydraulic fluid within the machine's system may be extremely hot and under high pressure.</p>
---	---

	<p style="text-align: center;">⚠ CAUTION</p> <p>When installing AutoBoom hydraulics or performing diagnostics, maintenance, or routine service, ensure precautions are taken to prevent any foreign material from being introduced into the machine's hydraulic system.</p> <p>Objects or materials that are able to bypass the machine's hydraulic filtration system will reduce performance and possibly damage the AutoBoom hydraulic valve.</p>
---	--

FIGURE 10. Machine's Pressure Hose Removed and Fitting Installed



1. Disconnect the machine's pressure hose from the machine's hydraulic valve.
2. Remove the machine's existing elbow fitting from the pressure port of the machine's hydraulic valve.

FIGURE 11. Machine's Pressure Hose Installed on the AutoBoom Valve

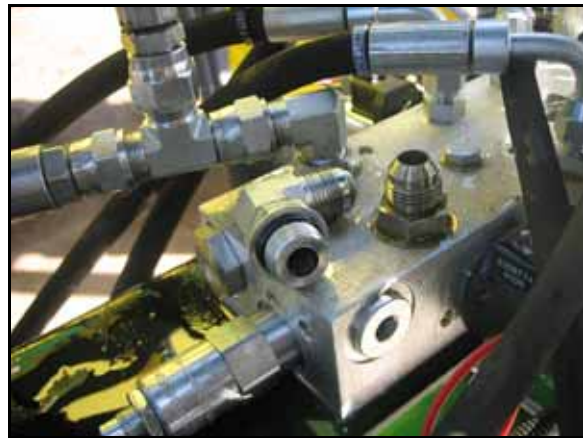
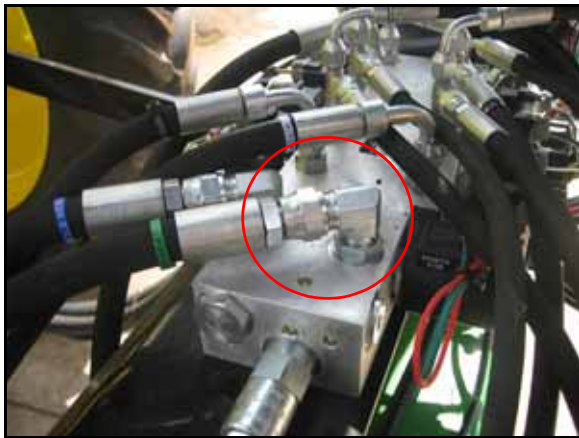
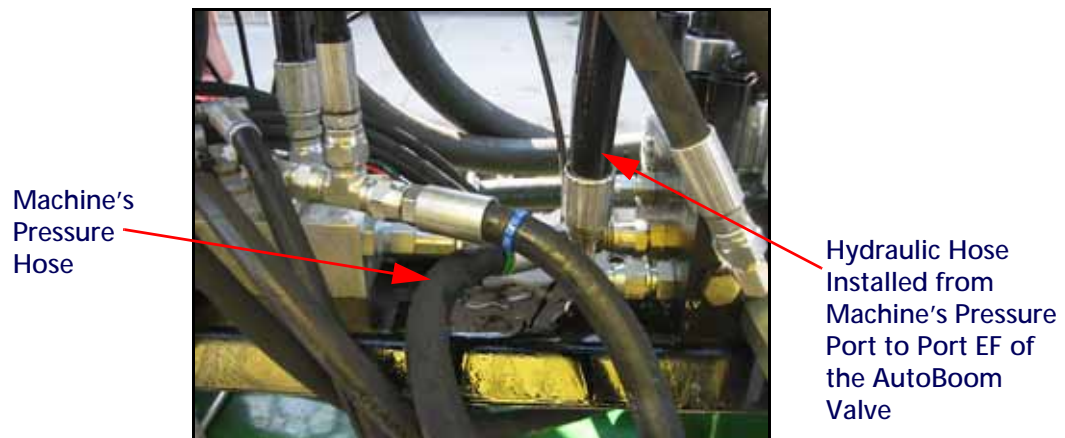

3. Connect the machine's pressure hose to the installed fittings in Port P of the AutoBoom valve.
4. Install a 3/4" SAE O-ring (M) to 3/4" JIC (M) straight adapter fitting (P/N 333-0012-093) in the pressure port of the machine's hydraulic valve.
5. Install the straight end of the supplied hydraulic hose (P/N 214-1000-609) on the installed fitting in the machine's pressure port.
6. Connect the 90° end of the installed hydraulic hose to the installed fitting in Port EF of the AutoBoom valve.

FIGURE 12. Tank (Return) Hose Installed



7. Disconnect the machine's return hose from the return port of the machine's hydraulic valve.
8. Install a 3/4" JIC M/M/F swivel run tee adapter fitting (P/N 333-0012-039) in the machine's return port.
9. Connect the machine's tank (return) hose to the opposite end of the installed tee fitting.
10. Install the straight end of the supplied hydraulic hose (P/N 214-1000-609) on the 90° end of the installed tee fitting.
11. Connect the 90° end of the installed hydraulic hose to the fittings installed in the Left T Port of the AutoBoom valve.

INSTALL THE LEFT AND RIGHT CYLINDER HOSES

FIGURE 13. Cylinder Hoses Installed

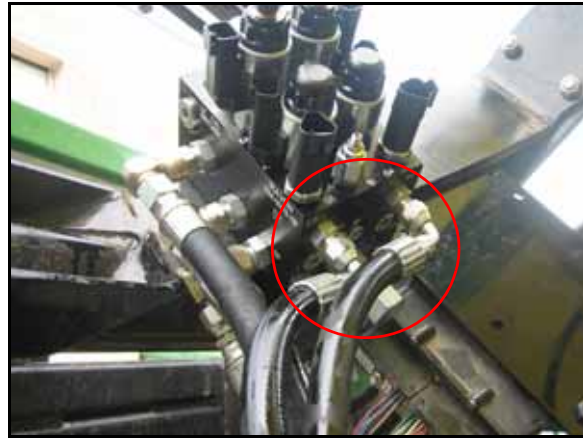
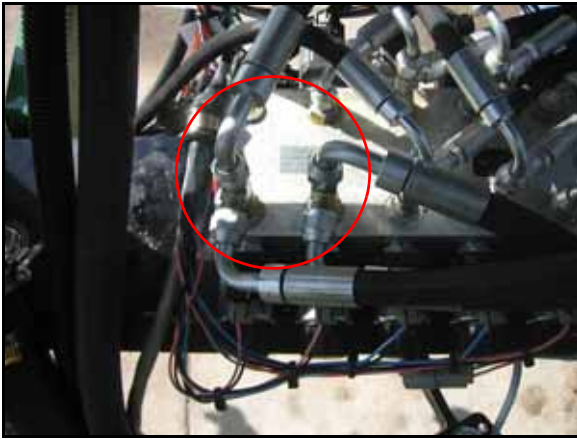

1. Disconnect the machine's cylinder up hoses from the left and right cylinder up ports of the machine's hydraulic valve.
2. Install 9/16" JIC M/M/F swivel run tee adapter fittings (P/N 333-0012-043) in the open ports on the machine's hydraulic valve.
3. Connect the machine's left cylinder hose to the opposite end of the installed tee fitting in the left cylinder up port of the machine's hydraulic valve.
4. Install the straight end of the supplied hydraulic hose (P/N 214-1000-610) on the 90° end of the installed tee fitting.
5. Connect the 90° end of the installed hydraulic hose to the fittings installed in Port LC of the AutoBoom valve.
6. Connect the machine's right cylinder hose to the opposite end of the installed tee fitting in the right cylinder up port of the machine's hydraulic valve.
7. Install the straight end of the supplied hydraulic hose (P/N 214-1000-610) on the 90° end of the installed tee fitting.
8. Connect the 90° end of the installed hydraulic hose to the fittings installed in Port RC of the AutoBoom valve.

POWERGLIDE PLUS HYDRAULIC SCHEMATIC

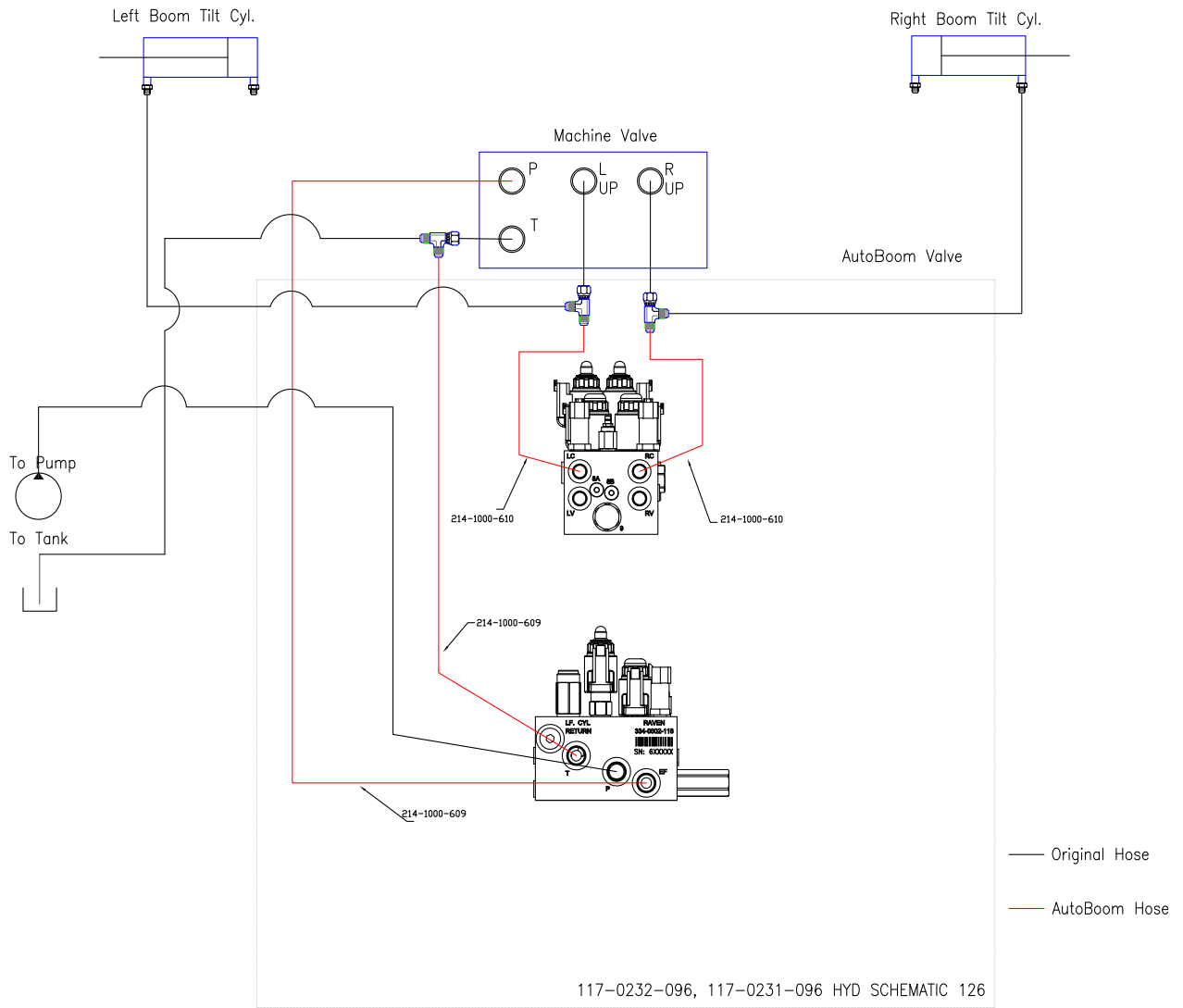

INSTALL THE GAUGE WHEELS

GAUGE WHEEL MOUNTING LOCATIONS

Wheel mounting locations may be influenced by the boom configuration. Determine the appropriate location for mounting the wheels on the boom, ensuring the wheels will not interfere with or be damaged while folding or unfolding the booms. The wheels should be mounted outside of the boom fold, but inside of the boom breakaway.

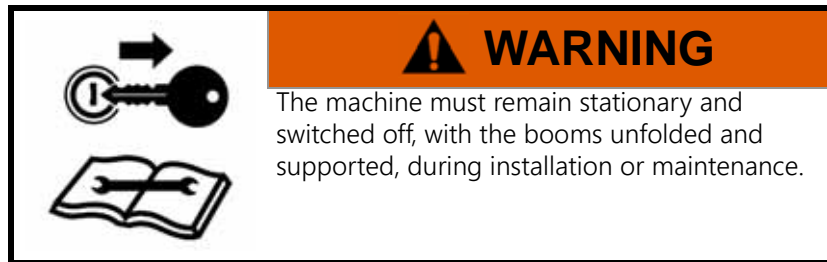

MOUNT THE GAUGE WHEELS

NOTE: The appearance of the wheel axles may vary.

FIGURE 14. Gauge Wheel Installed



1. Remove the lug nuts from the wheel axle (P/N 063-0131-590).
2. Place the wheel (P/N 322-0131-008) on the wheel axle.
3. Align and place the hub retainer bracket (P/N 107-0171-617) over the wheel
4. Reinstall the lug nuts on the wheel axle to secure the wheel and hub retainer bracket.
5. Mount the receiver bracket (P/N 116-0159-537) to the front of the left boom over the fold cylinder guide tube using two 5-1/16" W x 6" L x 7/16" thread U-bolts (P/N 107-0171-603) and four 7/16"-16 zinc flanged lock nuts (P/N 312-1001-165).
6. Insert the wheel axle into the receiver bracket, positioning it so that the bottom of the wheel touches the ground (or nearly so) and the wheel faces away from the machine.
7. Secure the gauge wheel assembly in the wheel mounting bracket by installing two 1/2"-13 x 1-1/2" SS hex bolts (P/N 311-0058-186) and two 1/2"-13 zinc hex nuts (P/N 312-1001-043).
8. Repeat the steps above to install the right wheel.

INSTALL THE POWERGLIDE PLUS WIRING

Wiring Connections

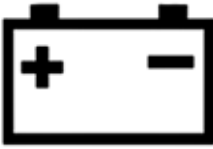
	<p>⚠ CAUTION</p>
<p>Always connect the power cable as the last step in the wiring process and verify that the power leads are connected with the correct polarity. Reversing power leads can cause severe damage to the equipment.</p>	

For wiring connections made outside the cab, apply dielectric silicone grease (P/N 222-0000-006) generously on both the male and female ends of the connectors. Application of the grease will prevent corrosion to the pins and wires.

INSTALL THE AUTOBOOM NODE

FIGURE 15. AutoBoom Node Installed



1. Use the existing holes on one edge of the supplied mounting plate (P/N 107-0171-619) as a guide to drill two 3/8" holes in the machine's center rack.
1. Place the AutoBoom node (P/N 063-0130-010) on the supplied mounting plate.
2. Use the AutoBoom node as a guide to mark and drill three 3/8" holes in the mounting plate.
3. Fasten the AutoBoom node to the mounting plate using three 3/8"-16 zinc hex bolts (P/N 311-0054-106) and three 3/8"-16 zinc flanged lock nuts (P/N 312-1001-164).
4. Using the drilled holes, secure the mounting plate to the machine's center rack using two 3/8"-16 zinc hex bolts (P/N 311-0054-106) and two 3/8"-16 zinc flanged lock nuts (P/N 312-1001-164).
5. Insert the large, rectangular node connectors on the harness cable (P/N 115-0230-045 or 115-0230-085) into the correct ports of the AutoBoom node.
6. Tighten the bolts on the node connectors to secure the connections.

CONNECT THE HARNESS TO THE BOOM FUNCTION CONTROLS

1. Locate the Left Press and Right Press connectors on the harness cable (P/N 115-0230-045 or 115-0230-085).
2. Route the connectors to the AutoBoom valve (P/N 063-0131-126).

3. Connect the Left Press connector to Port G1 on the AutoBoom valve.
4. Connect the Right Press connector to Port G4 on the AutoBoom valve.
5. Locate the Left Solenoid and Right Solenoid connectors on the harness cable.
6. Connect the Left Solenoid connector to Port 4A on the AutoBoom valve.
7. Connect the Right Solenoid connector to Port 13A on the AutoBoom valve.
8. Locate the Left Prop and Right Prop connectors on the harness cable.
9. Connect the Left Prop connector to Port 5A on the AutoBoom valve.
10. Connect the Right Prop connector to Port 13A on the AutoBoom valve.

FIGURE 16. Machine's Directional Valve



11. Locate the machine's directional valve.
12. Disconnect the machine's directional valve connector from the directional valve.
13. Install a boom sense adapter cable (P/N 115-0171-546) on the machine's directional valve connector.
14. Install the single weatherpack boom sense adapter cable (P/N 115-0171-790) on the installed boom sense adapter cable.
15. Connect the right and left Down connectors on the AutoBoom harness cable (P/N 115-0230-045 or 115-0230-085) to the connectors on the installed weatherpack boom sense adapter cable (P/N 115-0171-790).

FIGURE 17. Machine's Up Cylinder Wiring

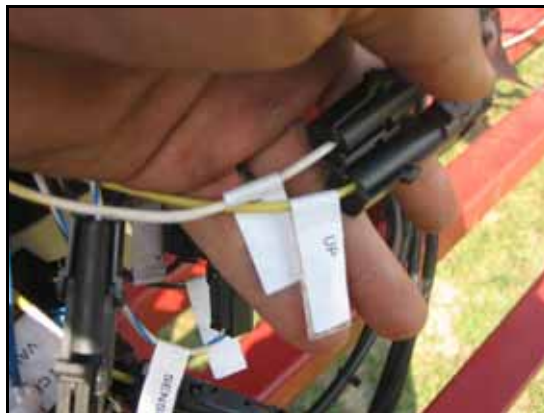

16. Install boom sense adapter cables (P/N 115-0171-546) between the machine's cylinder up coils and the connectors.

17. Connect the cable connectors to the Right Up and Left Up connectors on the AutoBoom harness (P/N 115-0230-045 or 115-0230-085) to the installed boom sense adapter cables.

CONNECT THE HARNESS CABLE TO THE IMPLEMENT EXTENSION TEE - GEN II CABLE ONLY

1. Route the harness cable (P/N 115-0230-085) toward the implement extension tee cable.
2. Connect the harness cable to the To Node connector.
3. Remove the terminator from the machine's chassis harness or the standalone console harness.
4. Install the terminator on the remaining open end of the implement extension tee cable.
5. Refer to the wiring schematic (beginning on page 40) appropriate for the machine's configuration to route the implement extension tee cable.
6. Connect the implement extension tee cable to the location determined in the step above.

CONNECT THE HARNESS CABLE TO THE CONTROLLER CABLE - GEN I CABLE ONLY

1. Route the harness cable (P/N 115-0230-045) toward the machine's cab.
2. Connect the harness cable to the controller cable (P/N 115-0230-007).
3. Tighten the connector screw cap to secure the connection.

CONNECT THE CONTROLLER (IF APPLICABLE) - GEN I CABLE ONLY

1. Route the controller cable (P/N 115-0230-007) into the right side of the machine's cab.
2. Locate the two controller connectors and connect them to the AutoBoom controller (P/N 063-0130-021).

NOTE: The AutoBoom controller should be mounted in the machine's cab so that the machine's operator has easy access to it.

CONNECT THE FIELD COMPUTER (IF APPLICABLE)

Refer to the Installation & Operation Manual and the appropriate wiring schematic beginning on page 40 for installation and wiring instructions for your specific field computer.

CONNECT THE POWER LEADS

1. Locate the power cable that has the power and ground leads at one end.
2. Disconnect the machine's connectors from the battery terminals.
3. Install the power lead on the positive battery terminal and reinstall the machine's battery connector.
4. Install the ground lead on the negative battery terminal and reinstall the machine's battery connector.

POWERGLIDE PLUS WIRING SCHEMATIC

GEN I CABLING

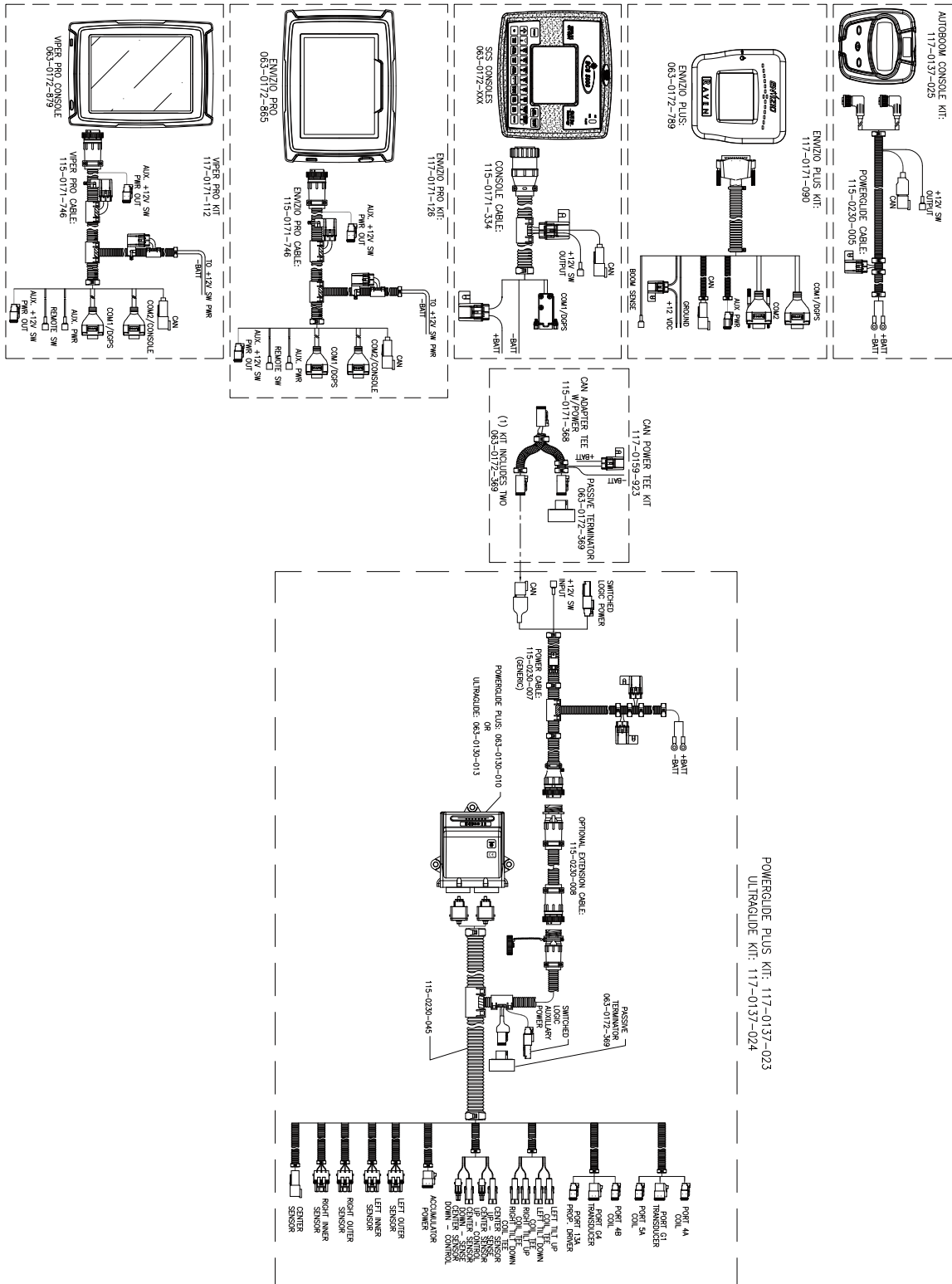

ULTRAGLIDE KIT CONTENTS

This section contains a list of the components that are included in the UltraGlide AutoBoom kit. Before beginning the AutoBoom installation, compare the items in the AutoBoom kit with the components on this list. If you have questions about the kit, contact your Raven dealer.

TABLE 1. UltraGlide Installation Kit (P/N 117-0232-096)

Picture	Item Description	Part Number	Qty.
Not Pictured	Manual - Fast 9600 - 80'-100' Booms AutoBoom Installation	016-0230-096	1
	Valve - PowerGlide Plus AutoBoom	063-0131-126	1
	Plate - Hydraulic Block Mounting	107-0171-619	1
	Sensor - Right Ultrasonic	063-0130-012	1
	Sensor - Left Ultrasonic	063-0130-014	1
	Sensor - Center Ultrasonic	063-0130-018	1
	Cable - Boom Sense Adapter	115-0171-546	3

TABLE 1. UltraGlide Installation Kit (P/N 117-0232-096)







Picture	Item Description	Part Number	Qty.
	Cable - 12' Extension	115-0230-008	1
	Cable - Center Rack Control Boom Sense Adapter	115-0230-039	2
	Cable - 2-Pin Deutsch Boom Sense Adapter	115-0230-081	1
	U-Bolt - 1-9/16" W x 2-1/2" L x 3/8" Thread	107-0171-611	4
	U-Bolt - 2" W x 7" L x 3/8" Thread	107-0171-855	2
	Bolt - 5/16"-18 x 1-1/4" Hex	311-0052-106	2
	Bolt - 3/8"-16 x 1-1/4" Zinc Hex	311-0054-106	5
	Nut - 3/8"-16 Zinc Flanged Lock	312-1001-164	17
	Washer - 5/16" Zinc Plated Lock	313-1000-019	2

TABLE 2. Hydraulic Kit (P/N 117-0134-096)

Picture	Item Description	Part Number	Qty.
	Fitting - 3/4" JIC M/M/F Swivel Run Tee Adapter	333-0012-039	1
	Fitting - 3/4" JIC M/F 45° Swivel Elbow	333-0012-040	1
	Fitting - 9/16" JIC M/M/F Swivel Run Tee Adapter	333-0012-043	2
	Fitting - 9/16" JIC (M) to 9/16" SAE O-Ring (M) Straight Adapter	333-0012-045	2
	Fitting - 3/4" SAE O-Ring (M) to 3/4" JIC (M) Straight Adapter	333-0012-093	4
	9/16" SAE O-Ring Internal Hex	333-0012-104	2
	Hydraulic Hose - 3/4" JIC (F) to 3/4" JIC (F) 90° - 24"	214-1000-609	2
	Hydraulic Hose - 9/16" JIC (F) to 9/16" JIC (F) 90° - 36"	214-1000-610	2

TABLE 3. Ultrasonic Sensor Bracket Installation Kit (P/N 117-0131-082)

Picture	Item Description	Part Number	Qty.
Not Pictured	Sheet - AutoBoom Sensor Extension	016-0130-070	1
	Bracket - 12" S-Type AutoBoom Sensor	063-0131-592	2

TABLE 3. Ultrasonic Sensor Bracket Installation Kit (P/N 117-0131-082)



Picture	Item Description	Part Number	Qty.
	Bolt - 5/16"-18 x 1-1/4" Hex	311-0052-106	2
	Nut - 5/16"-18 Nylon Insert Lock	312-4000-059	2
	Washer - 5/16" Zinc Flat	313-2300-012	4

TABLE 4. Optional Wheel Kit (P/N 117-0133-023)







Picture	Item Description	Part Number	Qty.
	Axle Assembly - Right Cushioned AutoBoom	063-0131-585	1
	Axle Assembly - Left Cushioned AutoBoom	063-0131-590	1
	Bracket - Fast Weldment Receiver	116-0159-537	2
	Bracket - Hub Retainer	107-0171-617	2
	Wheel	322-0131-008	2
	U-Bolt - 5-1/16" W x 6" L x 7/16" Thread	107-0171-603	4
	Bolt - 1/2"-13 x 1-1/2" SS Hex	311-0058-186	4

TABLE 4. Optional Wheel Kit (P/N 117-0133-023)

Picture	Item Description	Part Number	Qty.
	Nut - 1/2"-13 Zinc Hex	312-1001-043	4
	Nut - 7/16"-16 Zinc Flanged Lock	312-1001-165	8

TABLE 5. Gen I UltraGlide Wiring Kit (P/N 117-0137-024)





Picture	Item Description	Part Number	Qty.
Not Pictured	Manual - AutoBoom Calibration & Operation	016-0130-062	1
	Node - UltraGlide AutoBoom	063-0130-013	1
	Cable - Sensor	115-0171-527	2
	Cable - Harness	115-0230-045	1
	Cable - Power/CAN Controller	115-0230-007	1

TABLE 6. Gen II UltraGlide Wiring Kit (P/N 117-5130-003)



Picture	Item Description	Part Number	Qty.
Not Pictured	Manual - AutoBoom Calibration & Operation	016-0130-062	1
	Node - UltraGlide AutoBoom	063-0130-013	1

TABLE 6. Gen II UltraGlide Wiring Kit (P/N 117-5130-003)

Picture	Item Description	Part Number	Qty.
	Cable - Sensor	115-0171-527	2
	Cable - PowerGlide Plus/UltraGlide with CAN/Power Tee AutoBoom	115-0230-085	1

INSTALL THE ULTRAGLIDE HYDRAULIC SYSTEM

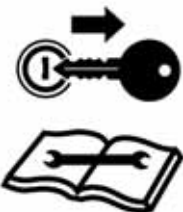

⚠ WARNING

The machine must remain stationary and switched off, with the booms unfolded and supported, during installation or maintenance.



⚠ CAUTION

When installing AutoBoom hydraulics or performing diagnostics, maintenance, or routine service, ensure precautions are taken to prevent any foreign material from being introduced into the machine's hydraulic system.

Objects or materials that are able to bypass the machine's hydraulic filtration system will reduce performance and possibly damage the AutoBoom hydraulic valve.



NOTICE

The appearance of the AutoBoom hydraulic valve may vary slightly from the images contained in this manual. However, the fittings, hose connections, and cable connections remain the same.

CONVERT THE SPRAYER'S HYDRAULIC VALVE TO OPEN CENTER (IF APPLICABLE)

By factory default, the machine's main hydraulic valve is configured as a "closed center" hydraulic system. In order for AutoBoom to function properly and to prevent the hydraulic system from overheating, Raven recommends converting the machine's hydraulic system to an "open center" system.

NOTE: Contact your Fast dealer to obtain the open center conversion kit.

FIGURE 1. Converted Hydraulic Valve - Closed Center to Open Center

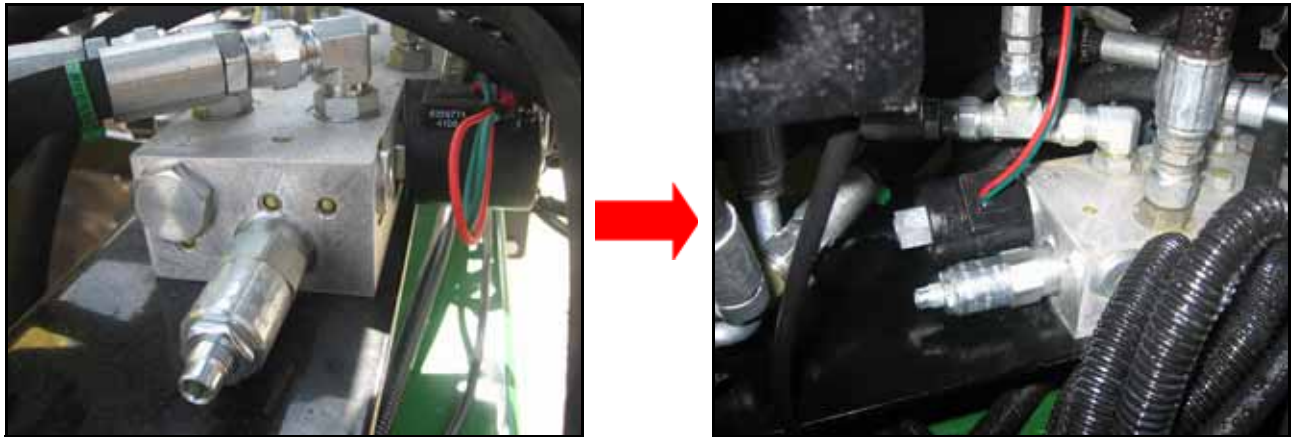

INSTALL FITTINGS ON THE AUTOBOOM VALVE

Before mounting the AutoBoom valve on the machine, install the proper fittings on the valve. This prepares the valve for installation and simplifies the hose connection process later in the procedure. Refer to the following table to install the fittings in the appropriate ports of the AutoBoom valve.

FIGURE 2. Fittings Installed on the AutoBoom Valve



Fitting	Part Number	Port
Fitting - 9/16" JIC (M) to 9/16" SAE O-Ring (M) Straight Adapter	333-0012-045	LC, RC
Fitting - 3/4" JIC (M) to 3/4" SAE O-Ring (M) Straight Adapter	333-0012-093	Left T, P, EF



Fitting	Part Number	Port
Fitting - 3/4" JIC M/F 45° Swivel Elbow	333-0012-040	P
Fitting - 9/16" SAE O-Ring Internal Hex Plug	333-0012-104	LV, RV

MOUNT THE AUTOBOOM VALVE

FIGURE 3. AutoBoom Valve Mounting Location



1. Verify that the existing holes in the machine's center rack (to the left of the machine's hydraulic valve) align with the mounting holes in the AutoBoom valve. If they do not, drill two 5/16" holes in the mounting location the same distance apart as the holes in the AutoBoom valve.
2. Secure the AutoBoom valve (P/N 063-0131-126) to the machine's center rack using two 5/16"-18 x 1-1/4" hex bolts (P/N 311-0052-106) and two 5/16" zinc lock washers (P/N 313-1000-019).

Install the Pressure and Tank Hoses



⚠ WARNING

Hydraulics are under pressure. Care should always be taken with a system that has been pressurized. When disconnecting or purging hydraulic hoses, be aware that the hydraulic fluid within the machine's system may be extremely hot and under high pressure.

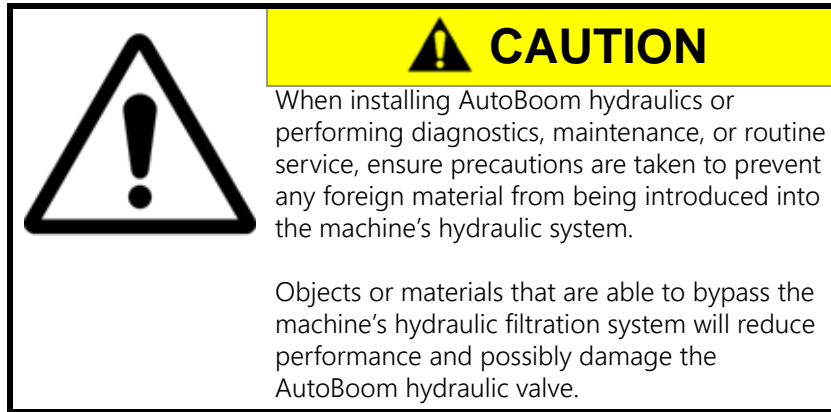
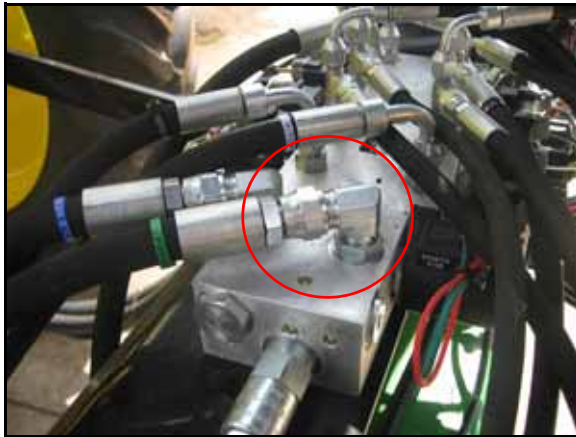
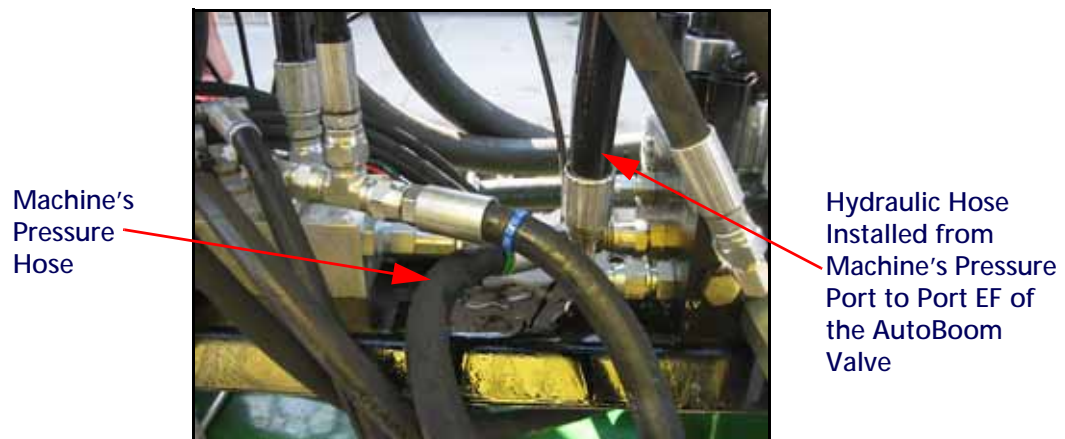

FIGURE 4. Machine's Pressure Hose Removed and Fitting Installed



1. Disconnect the machine's pressure hose from the machine's hydraulic valve.
2. Remove the machine's existing elbow fitting from the pressure port of the machine's hydraulic valve.

FIGURE 5. Machine's Pressure Hose Installed on the AutoBoom Valve



3. Connect the machine's pressure hose to the installed fittings in Port P of the AutoBoom valve.
4. Install a 3/4" SAE O-ring (M) to 3/4" JIC (M) straight adapter fitting (P/N 333-0012-093) in the pressure port of the machine's hydraulic valve.

5. Install the straight end of the supplied hydraulic hose (P/N 214-1000-609) on the installed fitting in the machine's pressure port.
6. Connect the 90° end of the installed hydraulic hose to the installed fitting in Port EF of the AutoBoom valve.

FIGURE 6. Tank (Return) Hose Installed

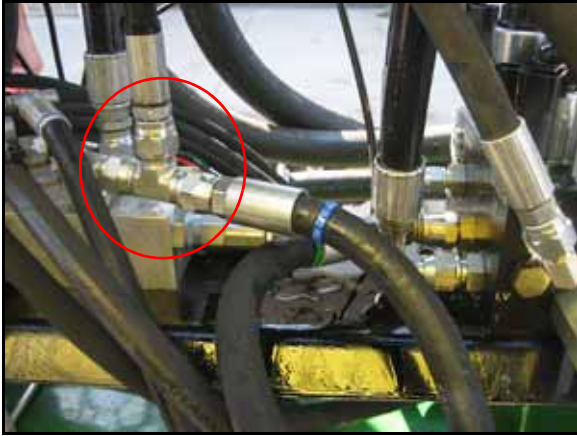

7. Disconnect the machine's return hose from the return port of the machine's hydraulic valve.
8. Install a 3/4" JIC M/M/F swivel run tee adapter fitting (P/N 333-0012-039) in the machine's return port.
9. Connect the machine's tank (return) hose to the opposite end of the installed tee fitting.
10. Install the straight end of the supplied hydraulic hose (P/N 214-1000-609) on the 90° end of the installed tee fitting.
11. Connect the 90° end of the installed hydraulic hose to the fittings installed in the Left T Port of the AutoBoom valve.

INSTALL THE LEFT AND RIGHT CYLINDER HOSES

FIGURE 7. Cylinder Hoses Installed

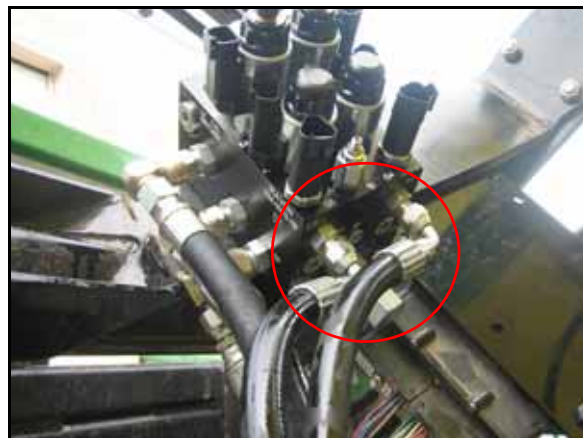
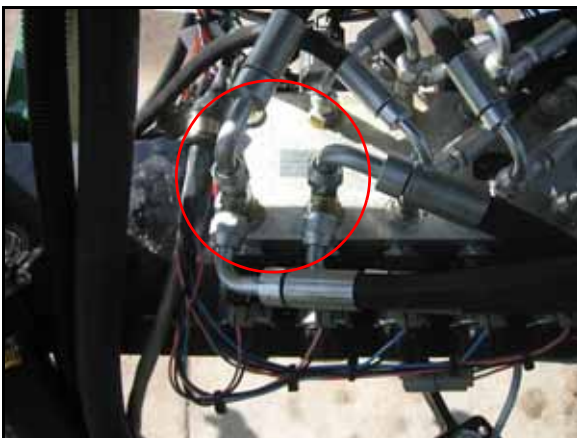

1. Disconnect the machine's cylinder up hoses from the left and right cylinder up ports of the machine's hydraulic valve.
2. Install 9/16" JIC M/M/F swivel run tee adapter fittings (P/N 333-0012-043) in the open ports on the machine's hydraulic valve.

3. Connect the machine's left cylinder hose to the opposite end of the installed tee fitting in the left cylinder up port of the machine's hydraulic valve.
4. Install the straight end of the supplied hydraulic hose (P/N 214-1000-610) on the 90° end of the installed tee fitting.
5. Connect the 90° end of the installed hydraulic hose to the fittings installed in Port LC of the AutoBoom valve.
6. Connect the machine's right cylinder hose to the opposite end of the installed tee fitting in the right cylinder up port of the machine's hydraulic valve.
7. Install the straight end of the supplied hydraulic hose (P/N 214-1000-610) on the 90° end of the installed tee fitting.
8. Connect the 90° end of the installed hydraulic hose to the fittings installed in Port RC of the AutoBoom valve.

ULTRAGLIDE HYDRAULIC SCHEMATIC

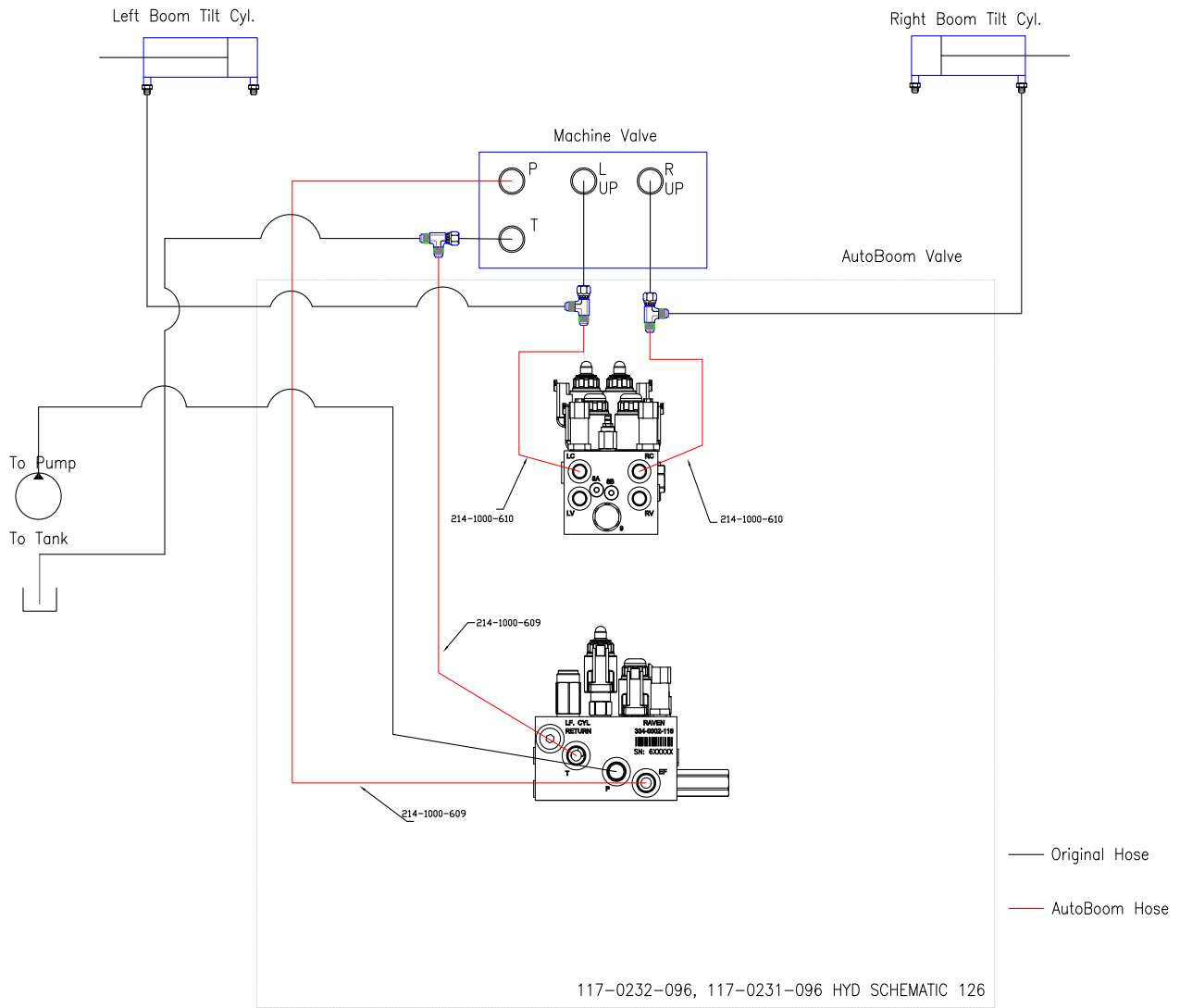

INSTALL THE ULTRAGLIDE SENSORS

BOOM SENSOR MOUNTING LOCATIONS

Sensor mounting locations may be influenced by the boom configuration. If an object enters the sensor's blind range unexpectedly, a false echo return to the sensor could occur, causing the boom to drop and the sensor or boom to be damaged. To ensure optimal operation of the UltraGlide system and to protect the sprayer boom, the sensors should be mounted on the front side of the boom, 8 - 10" above the lowest hanging part of the boom.

FIGURE 8. Illustration of Sensor's Blind Range

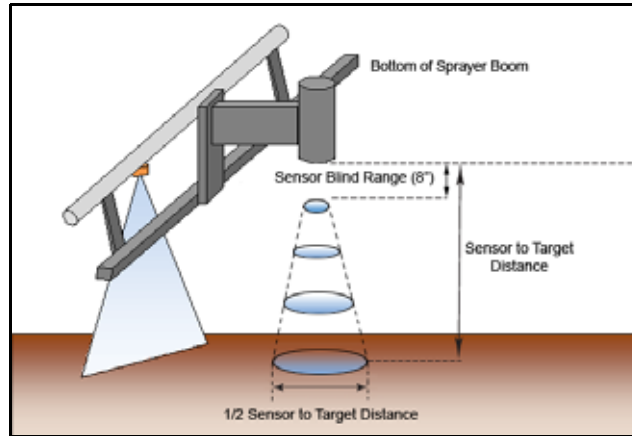

Mount the Boom Sensors



⚠ WARNING

The machine must remain stationary and switched off, with the booms unfolded and supported, during installation or maintenance.

FIGURE 9. Mounted Boom Sensor



1. Locate the left and right ultrasonic sensors (P/N 063-0130-012 and 063-0130-014) in the AutoBoom installation kit.
2. Remove the sensor from the existing plastic arm.
3. Install the sensors on the 12" S-type sensor arms (P/N 063-0131-592) using the supplied 5/16"-18 x 1-1/4" bolts (P/N 311-0052-106), 5/16"-18 nylon insert lock nuts (P/N 312-4000-059) and 5/16" zinc flat washers (P/N 313-2300-012).
4. Secure the left sensor (P/N 063-0130-014) to the front of the left boom using two 1-9/16" W x 2-1/2" L x 3/8" thread U-bolts (P/N 107-0171-611) and four 3/8"-16 zinc flanged lock nuts (P/N 312-1001-164).
5. Tighten the nuts to ensure the sensor is mounted securely.
6. Repeat the steps above to mount the remaining boom sensor(s).

MOUNT THE CENTER RACK SENSOR

FIGURE 10. Center Rack Sensor



1. Mount the center sensor (P/N 063-0130-018) to the machine's center rack using two 2" W x 7" L x 3/8" thread U-bolts (P/N 107-0171-855) and four 3/8"-16 zinc flanged lock nuts (P/N 312-1001-164).
2. Tighten the nuts to ensure the sensor is mounted securely.

CONNECT THE SENSOR CABLES

1. Connect the left sensor cable (P/N 115-0171-527) to the connector on the outer left sensor.
2. Route the left sensor cable toward the AutoBoom valve.
3. Loop and tie-off any excess cabling, allowing enough cable for boom folding and extension.
4. Repeat the steps above to connect the remaining sensor cables.

NOTE: The sensor cables will be connected to the AutoBoom system in the wiring phase of installation.

INSTALL THE GAUGE WHEELS - OPTIONAL

GAUGE WHEEL MOUNTING LOCATIONS

Wheel mounting locations may be influenced by the boom configuration. Determine the appropriate location for mounting the wheels on the boom, ensuring the wheels will not interfere with or be damaged while folding or

unfolding the booms. The wheels should be mounted outside of the boom fold, but inside of the boom breakaway.

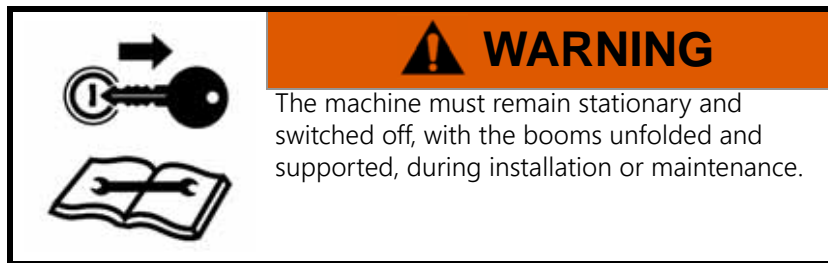

MOUNT THE GAUGE WHEELS

NOTE: The appearance of the wheel axles may vary.

FIGURE 11. Gauge Wheel Installed



1. Remove the lug nuts from the wheel axle (P/N 063-0131-590).
2. Place the wheel (P/N 322-0131-008) on the wheel axle.
3. Align and place the hub retainer bracket (P/N 107-0171-617) over the wheel
4. Reinstall the lug nuts on the wheel axle to secure the wheel and hub retainer bracket.
5. Mount the receiver bracket (P/N 116-0159-537) to the front of the left boom over the fold cylinder guide tube using two 5-1/16" W x 6" L x 7/16" thread U-bolts (P/N 107-0171-603) and four 7/16"-16 zinc flanged lock nuts (P/N 312-1001-165).
6. Insert the wheel axle into the receiver bracket, positioning it so that the bottom of the wheel touches the ground (or nearly so) and the wheel faces away from the machine.
7. Secure the gauge wheel assembly in the wheel mounting bracket by installing two 1/2"-13 x 1-1/2" SS hex bolts (P/N 311-0058-186) and two 1/2"-13 zinc hex nuts (P/N 312-1001-043).
8. Repeat the steps above to install the right wheel.

INSTALL THE ULTRAGLIDE WIRING

Wiring Connections

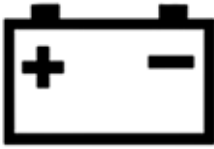
	<p style="text-align: center;">⚠ CAUTION</p> <p>Always connect the power cable as the last step in the wiring process and verify that the power leads are connected with the correct polarity. Reversing power leads can cause severe damage to the equipment.</p>
---	---

For wiring connections made outside the cab, apply dielectric silicone grease (P/N 222-0000-006) generously on both the male and female ends of the connectors. Application of the grease will prevent corrosion to the pins and wires.

INSTALL THE AUTOBOOM NODE

FIGURE 12. AutoBoom Node Installed



1. Use the existing holes on one edge of the supplied mounting plate (P/N 107-0171-619) as a guide to drill two 3/8" holes in the machine's center rack.
2. Place the AutoBoom node (P/N 063-0130-013) on the supplied mounting plate.
3. Use the AutoBoom node as a guide to mark and drill three 3/8" holes in the mounting plate.
4. Fasten the AutoBoom node to the mounting plate using three 3/8"-16 zinc hex bolts (P/N 311-0054-106) and three 3/8"-16 zinc flanged lock nuts (P/N 312-1001-164).
5. Using the drilled holes, secure the mounting plate to the machine's center rack using two 3/8"-16 zinc hex bolts (P/N 311-0054-106) and two 3/8"-16 zinc flanged lock nuts (P/N 312-1001-164).
6. Insert the large, rectangular node connectors on the harness cable (P/N 115-0230-045 or 115-0230-085) into the correct ports of the AutoBoom node.
7. Tighten the bolts on the node connectors to secure the connections.

CONNECT THE HARNESS TO THE BOOM FUNCTION CONTROLS

1. Locate the Left Press and Right Press connectors on the harness cable (P/N 115-0230-045 or 115-0230-085).
2. Route the connectors to the AutoBoom valve (P/N 063-0131-126).

3. Connect the Left Press connector to Port G1 on the AutoBoom valve.
4. Connect the Right Press connector to Port G4 on the AutoBoom valve.
5. Locate the Left Solenoid and Right Solenoid connectors on the harness cable.
6. Connect the Left Solenoid connector to Port 4A on the AutoBoom valve.
7. Connect the Right Solenoid connector to Port 4B on the AutoBoom valve.
8. Locate the Left Prop and Right Prop connectors on the harness cable.
9. Connect the Left Prop connector to Port 5A on the AutoBoom valve.
10. Connect the Right Prop connector to Port 13A on the AutoBoom valve.
11. Disconnect the machine's harness cable connection from the left up coil on the machine's hydraulic valve.
12. Install a boom sense adapter cable (P/N 115-0171-546) on the coil.
13. Connect the machine's harness cable to the installed boom sense adapter cable.
14. Disconnect the machine's harness cable connection from the right up coil on the machine's hydraulic valve.
15. Install a boom sense adapter cable (P/N 115-0171-546) on the coil.
16. Connect the machine's harness cable to the installed boom sense adapter cable.

FIGURE 13. Machine's Up Cylinder Wiring

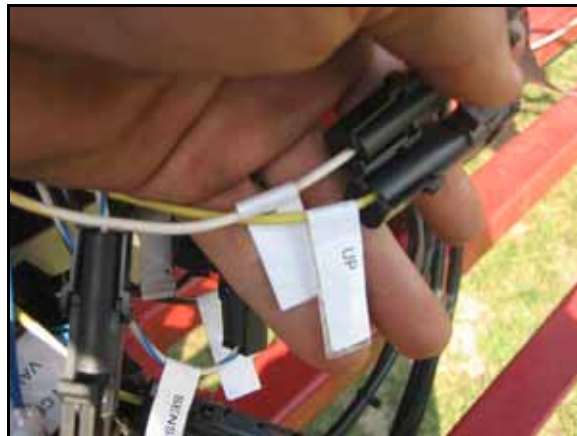

17. Connect the Left and Right Up connectors on the AutoBoom harness (P/N 115-0230-045 or 115-0230-085) to the installed boom sense adapter cables.

FIGURE 14. Machine's Open Center Coil



18. Disconnect the machine's harness cable connection from the open center coil on the machine's hydraulic valve.

19. Install a boom sense adapter cable (P/N 115-0171-546) on the open center coil.
20. Connect the machine's harness cable to the installed boom sense adapter cable.
21. Connect the Open Center Valve connection on the AutoBoom harness cable to the single weatherpack connection of the installed boom sense adapter cable.

NOTE: The system will now disengage when Up is pressed on the machine's controller. The system must be engaged via the AutoBoom controller or field computer screen.

INSTALL THE CENTER RACK CONTROL

FIGURE 15. Machine's Directional Coil

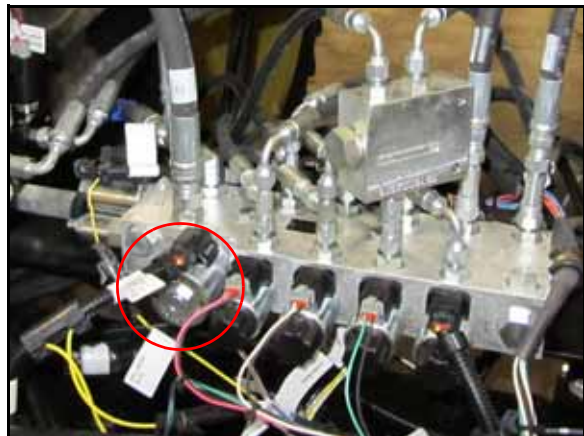
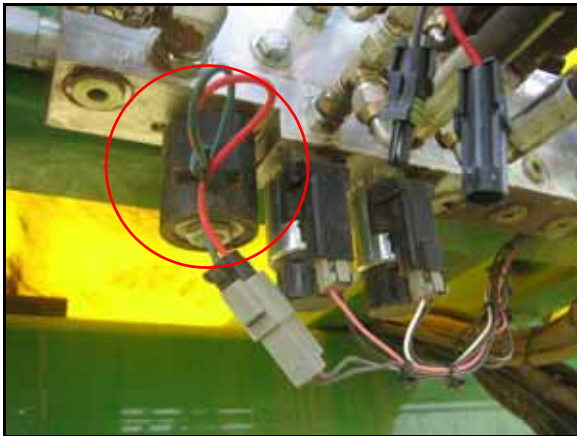

1. Locate the machine's directional coil.
2. Disconnect the machine's directional coil connector from the directional coil.
3. Install the center rack control boom sense adapter cable on the machine's directional coil connector.
 - Black directional coil with permanent lead wire attached to the coil, install cable P/N 115-0230-081.
 - Silver directional coil with built-in Deutsch connector, install cable P/N 115-0230-039.
4. Connect the Center Solenoid Down Sense connections on the AutoBoom harness (P/N 115-0230-045 or 115-0230-085) cable to the Open single weatherpack connections on the center rack control boom sense adapter cable (P/N 115-0230-081 or 115-0230-039).

FIGURE 16. Center Rack Control Coil



5. Locate the machine's center rack coil.
6. Disconnect the machine's connections from the center rack control valve.
7. Install the center rack control boom sense adapter cable (P/N 115-0230-039) on the machine's center rack control coil.
8. Connect the machine's connections to the installed center rack control boom sense adapter cable.
9. Connect the center rack control boom sense adapter cable to the Center Solenoid Up Sense and Control connections on the AutoBoom harness cable.

CONNECT THE HARNESS CABLE TO THE SENSORS

1. Locate the Center Sensor connector on the AutoBoom harness cable.
2. Connect the Center Sensor connector to the installed center sensor (P/N 063-0130-018).
3. Locate the Left Outer Sensor connector on the AutoBoom harness cable.
4. Connect the Left Outer Sensor connector to the installed left sensor cable (P/N 115-0171-527).
5. Locate the Right Outer Sensor connector on the AutoBoom harness cable.
6. Connect the Right Outer Sensor connector to the installed right sensor cable.
7. If optional inside boom sensors are installed, repeat the steps above to connect the sensor cables.

CONNECT THE HARNESS CABLE TO THE IMPLEMENT EXTENSION TEE - GEN II CABLE ONLY

1. Route the harness cable (P/N 115-0230-085) toward the implement extension tee cable.
2. Connect the harness cable to the To Node connector.
3. Remove the terminator from the machine's chassis harness or the standalone console harness.
4. Install the terminator on the remaining open end of the implement extension tee cable.
5. Refer to the wiring schematic (beginning on page 63) appropriate for the machine's configuration to route the implement extension tee cable.
6. Connect the implement extension tee cable to the location determined in the step above.

CONNECT THE HARNESS CABLE TO THE CONTROLLER CABLE - GEN I CABLE ONLY

1. Route the harness cable (P/N 115-0230-045) toward the machine's cab.
2. Connect the harness cable to the controller cable (P/N 115-0230-007).
3. Tighten the connector screw cap to secure the connection.

CONNECT THE CONTROLLER (IF APPLICABLE) - GEN I CABLE ONLY

1. Route the controller cable (P/N 115-0230-007) into the right side of the machine's cab.
2. Locate the two controller connectors and connect them to the AutoBoom controller (P/N 063-0130-021).

NOTE: The AutoBoom controller should be mounted in the machine's cab so that the machine's operator has easy access to it.

CONNECT THE FIELD COMPUTER (IF APPLICABLE)

Refer to the Installation & Operation Manual and the appropriate wiring schematic beginning on page 63 for installation and wiring instructions for your specific field computer.

CONNECT THE POWER LEADS

1. Locate the power cable that has the power and ground leads at one end.
2. Disconnect the machine's connectors from the battery terminals.

3. Install the power lead on the positive battery terminal and reinstall the machine's battery connector.
4. Install the ground lead on the negative battery terminal and reinstall the machine's battery connector.

ULTRAGLIDE WIRING SCHEMATIC

GEN I CABLING

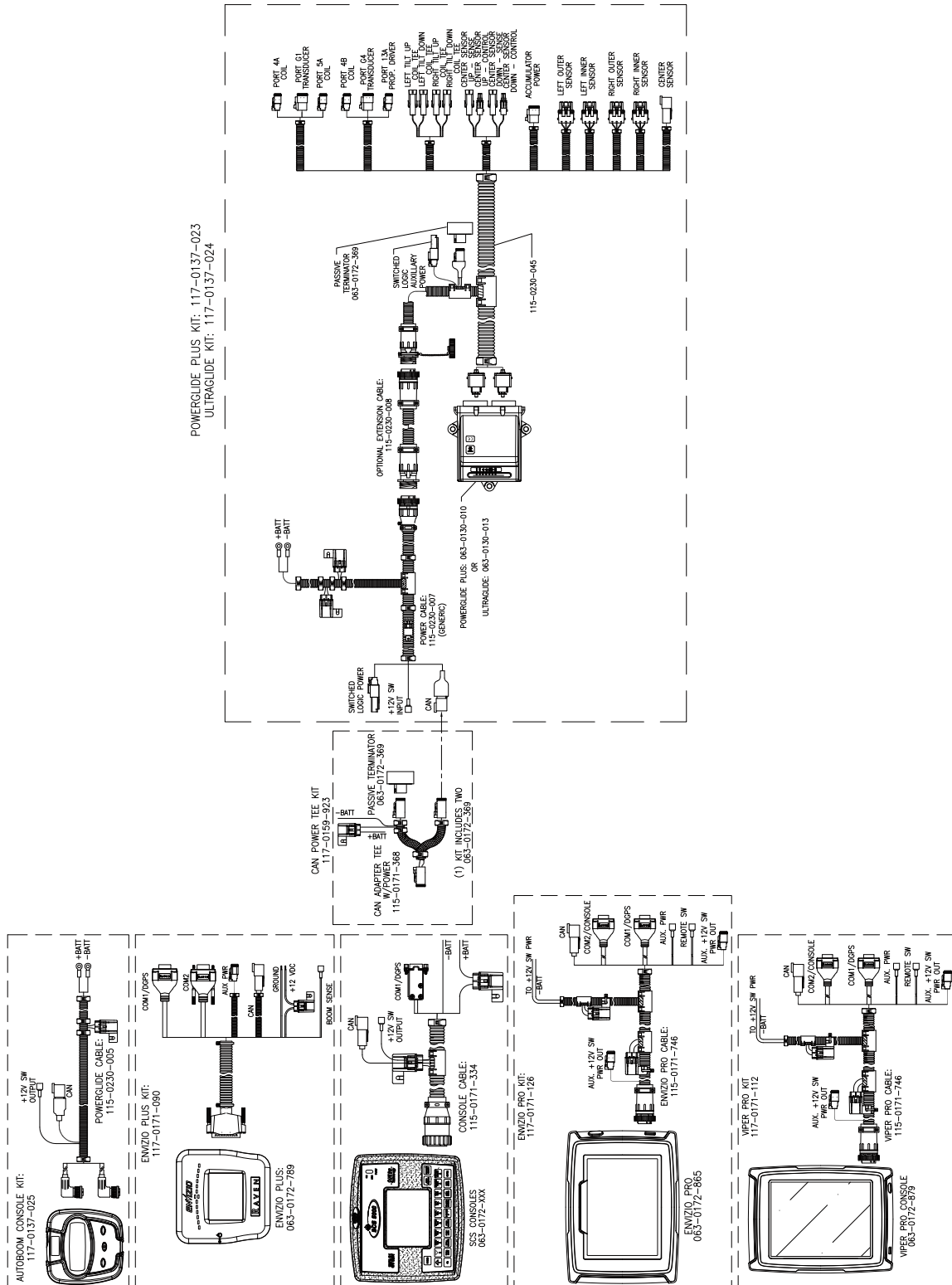

GEN II CABLING

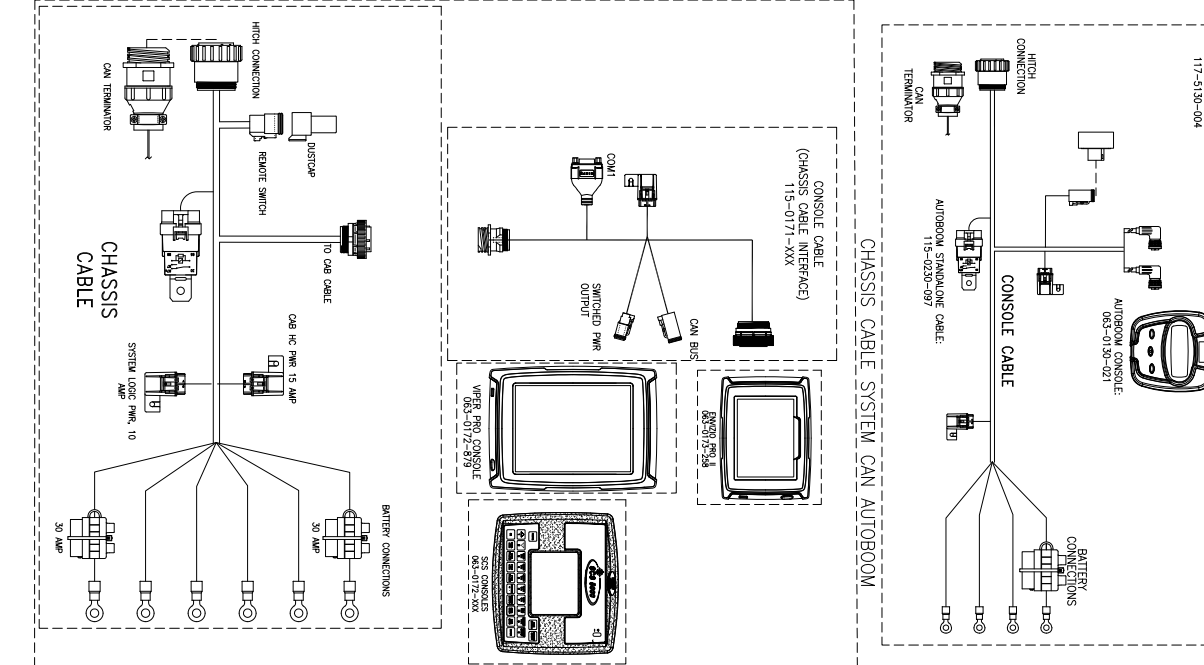
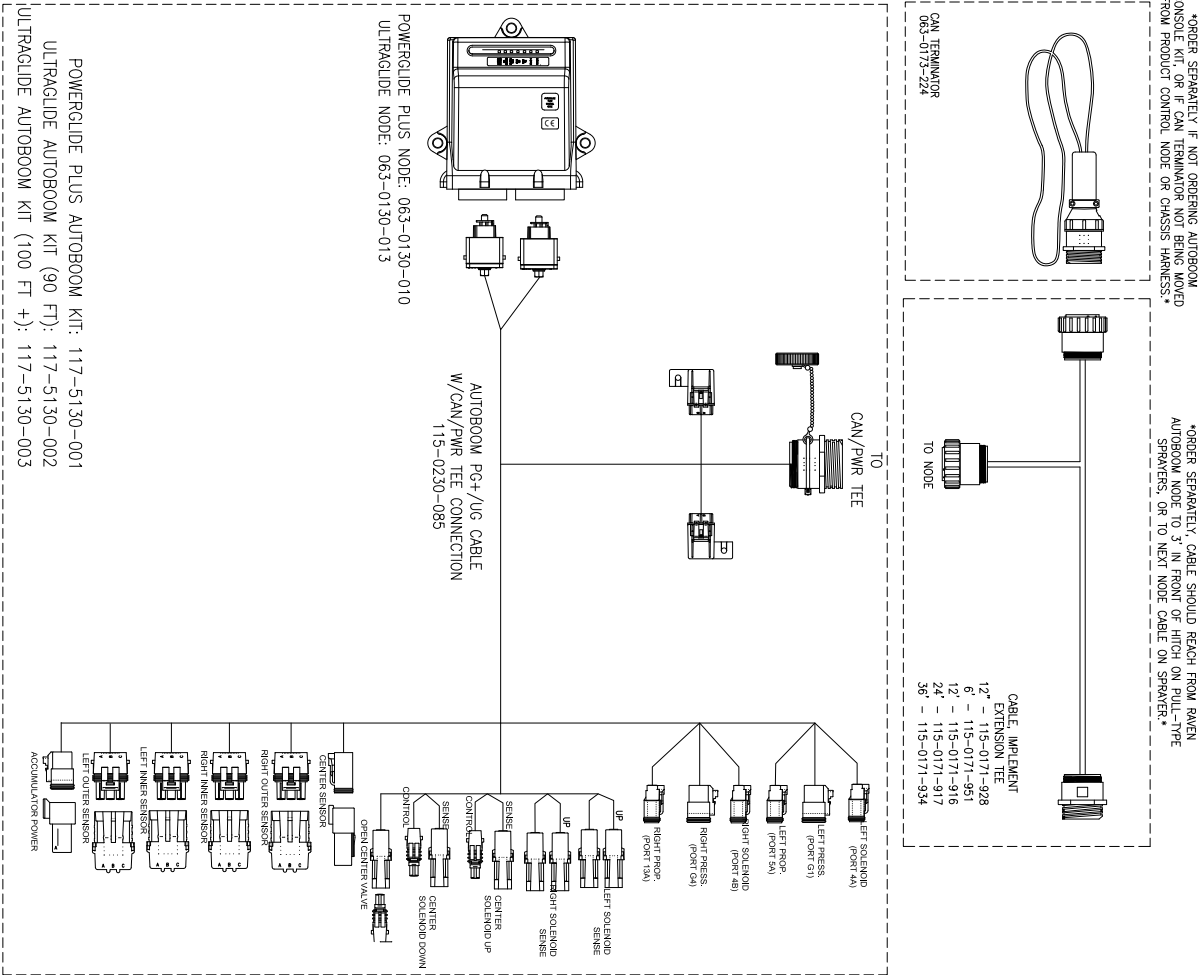

CHAPTER

REPLACEMENT PARTS

6

This section contains replacement part diagrams for PowerGlide, PowerGlide Plus, and UltraGlide systems. Refer to these diagrams when calling to request replacement parts.

VALVE BLOCKS

POWERGLIDE VALVE REPLACEMENT PARTS

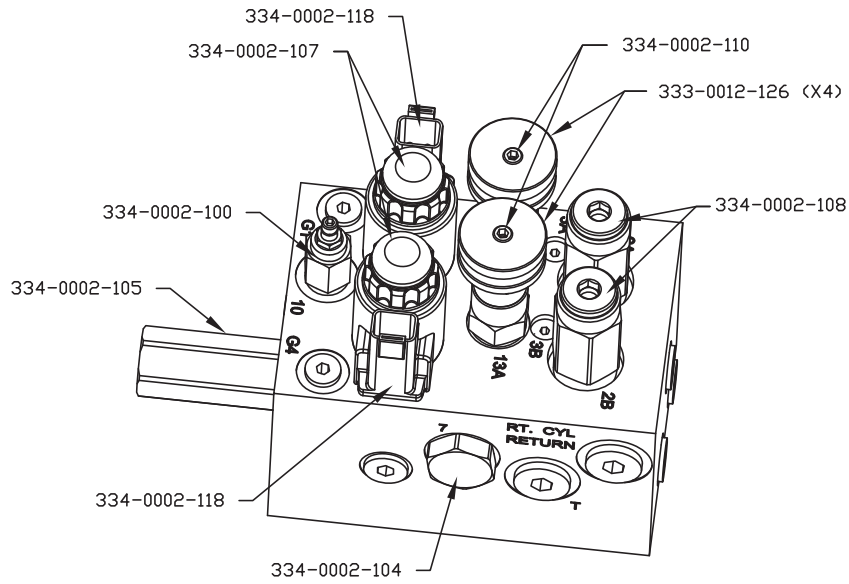

063-0131-127
VALVE, HYDRAULIC POWERGLIDE,
OPEN CENTER, AUTOBOOM

POWERGLIDE PLUS AND ULTRAGLIDE VALVE REPLACEMENT PARTS

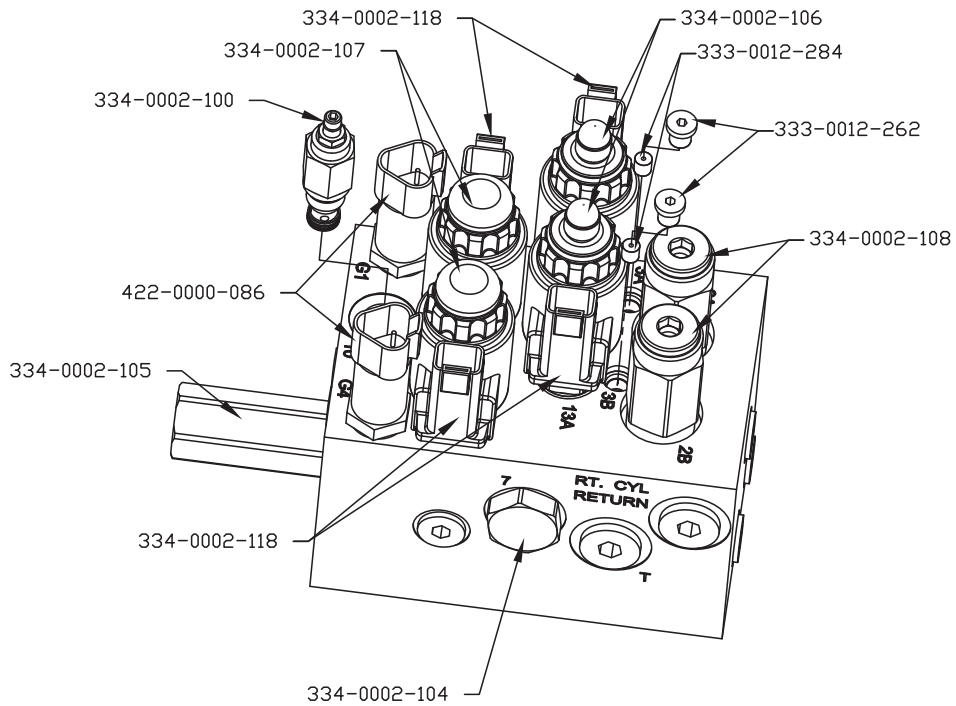

063-0131-126
VALVE, HYDRAULIC POWERGLIDE
PLUS/ULTRAGLIDE, OPEN CENTER, AUTOBOOM

WHEELS

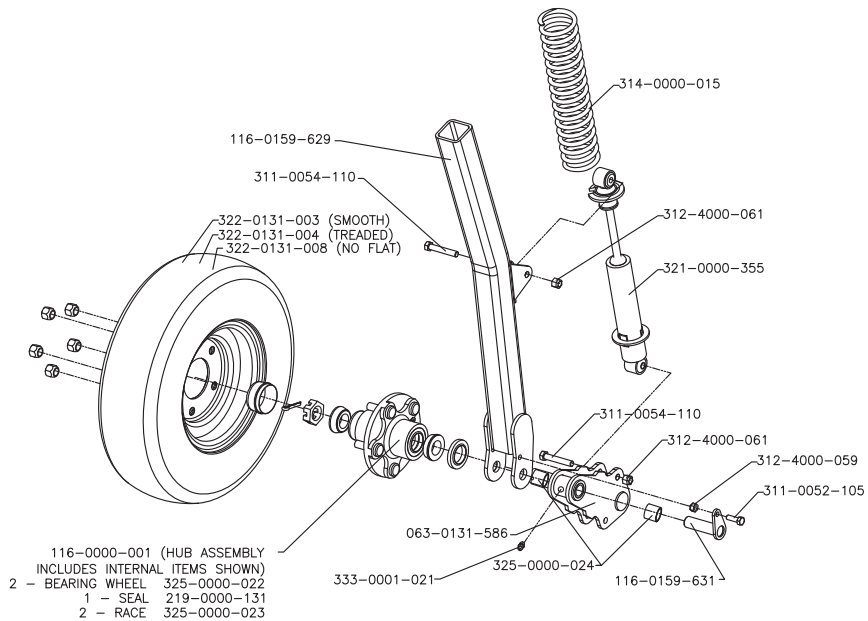

SENSORS

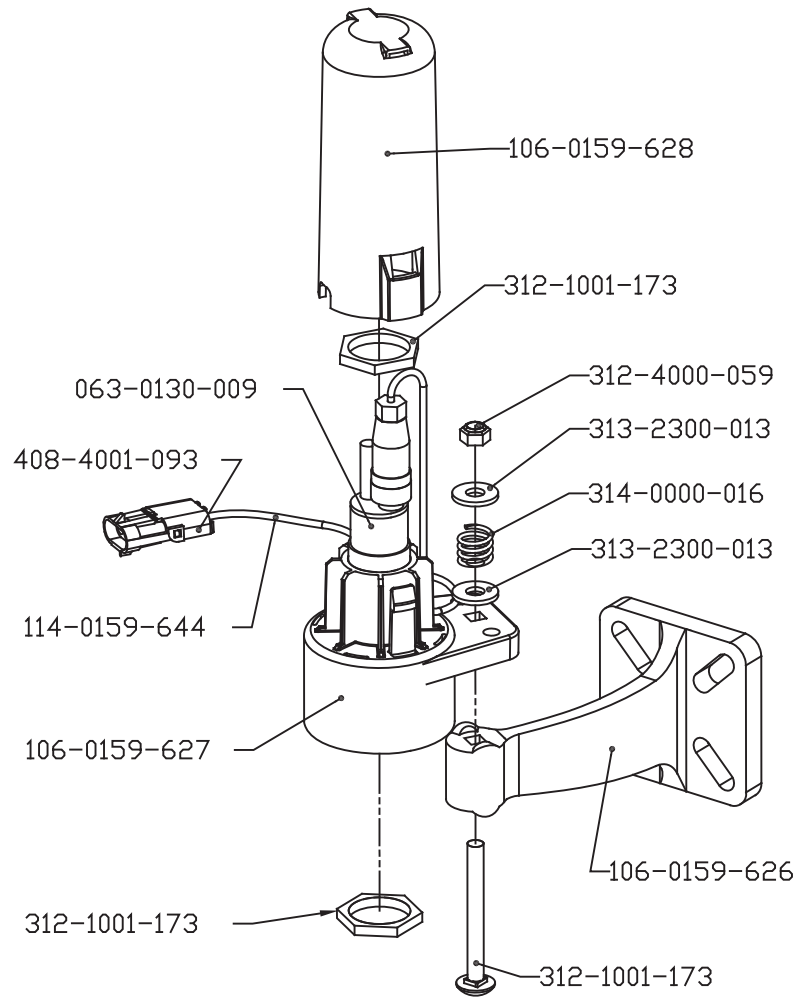

H

- Hydraulic
 - Fittings 6
- Hydraulic Safety 2

I

- Important Safety Information
 - Hydraulic Safety 2
- Introduction
 - Hydraulic Fittings 6
 - Preparing for Installation 5
 - Point of Reference 6
 - Recommendations 6
 - Tools Needed 6

K

- Kit Contents
 - PowerGlide 9
 - PowerGlide Plus 23
 - UltraGlide 43

P

- Point of Reference 6
- PowerGlide 9
 - Install
 - Gauge Wheels 19
 - Gauge Wheel Mounting Locations 19
 - Mounting the Gauge Wheels 19
 - Hydraulic System 12
 - Converting the Sprayer's Hydraulic Valve to Open Center 12
 - Hydraulic Schematic 18
 - Installing Fittings on the AutoBoom Valve 13, 30
 - Installing the Left and Right Cylinder Hoses 16
 - Installing the Pressure and Tank Hoses 14
 - Mounting the AutoBoom Valve 14
 - Wiring 20
 - Connecting the Controller 21
 - Connecting the Harness to the Boom Function Controls 20
 - Connecting the Harness to the Controller Cable 20
 - Connecting the Power Leads 21
 - Wiring Connections 20
 - Wiring Schematic 22
- Kit Contents 9
- PowerGlide Plus 23
 - Install
 - Gauge Wheels 36
 - Gauge Wheel Mounting Locations 36
 - Mounting the Gauge Wheels 36
 - Hydraulic System 27
 - Converting the Sprayer's Hydraulic Valve to Open Center 27
 - Hydraulic Schematic 35
 - Installing the Left and Right Cylinder Hoses 34
 - Installing the Pressure and Tank Hoses 32
 - Mounting the AutoBoom Valve 31

Removing the Orifice Fittings 28

Wiring 37

Connecting the Controller 39

Connecting the Field Computer 39

Connecting the Harness Cable to the Controller Cable 39

Connecting the Harness Cable to the Controller Cable - Gen I Cable Only 39

Connecting the Harness Cable to the Implement Extension Tee - Gen II Cable Only 39

Connecting the Harness to the Boom Function Controls 37

Connecting the Harness to the Controller Cable 39

Connecting the Power Leads 39

Installing the AutoBoom Node 37

Wiring Connections 37

Wiring Schematics

Gen I Cabling 40

Gen II Cabling 41

Kit Contents 23

R

Recommendations 6

Replacement Parts

Sensors 68

Valve Blocks 66

PowerGlide 66

PowerGlide Plus and UltraGlide 67

Wheels 67

T

Tools Needed 6

U

UltraGlide 43

Install

Gauge Wheels 56

Gauge Wheel Mounting Locations 56

Mounting the Gauge Wheels 57

Hydraulic System 48

Converting the Sprayer's Hydraulic Valve to Open Center 49

Hydraulic Schematic 54

Installing Fittings on the AutoBoom Valve 49

Installing the Left and Right Cylinder Hoses 52

Installing the Pressure and Tank Hoses 50

Mounting the AutoBoom Valve 50

Sensors

Boom Sensor Mounting Locations 55

Connecting the Sensor Cables 56

Mounting the Boom Sensors 55

Mounting the Center Rack Sensor 56

Wiring 58

Connecting the Controller 61

Connecting the Field Computer 61

Connecting the Harness Cable to the Controller Cable - Gen I Cable Only 61

Connecting the Harness Cable to the Implement Extension Tee - Gen II Cable Only 61

Connecting the Harness Cable to the Sensors	61
Connecting the Harness to the Boom Function Controls	58
Connecting the Power Leads	61
Installing the AutoBoom Node	58
Installing the Center Rack Control	60
Wiring Connections	58
Wiring Schematics	
Gen I Cabling	63
Gen II Cabling	64
Kit Contents	43

RAVEN

Limited Warranty

What Does this Warranty Cover?

This warranty covers all defects in workmanship or materials in your Raven Applied Technology Division product under normal use, maintenance, and service when used for intended purpose.

How Long is the Coverage Period?

Raven Applied Technology products are covered by this warranty for 12 months from the date of retail sale. In no case will the Limited Warranty period exceed 24 months from the date the product was issued by Raven Industries Applied Technology Division. This warranty coverage applies only to the original owner and is non-transferable.

How Can I Get Service?

Bring the defective part and proof of purchase to your Raven dealer. If the dealer approves the warranty claim, the dealer will process the claim and send it to Raven Industries for final approval. The freight cost to Raven Industries will be the customer's responsibility. The Return Materials Authorization (RMA) number must appear on the box and all documentation (including proof of purchase) must be included inside the box to be sent to Raven Industries.

What Will Raven Industries Do?

Upon confirmation of the warranty claim, Raven Industries will (at our discretion) repair or replace the defective product and pay for the standard return freight, regardless of the inbound shipping method. Expedited freight is available at the customer's expense.

What is not Covered by this Warranty?

Raven Industries will not assume any expense or liability for repairs made outside our facilities without written consent. Raven Industries is not responsible for damage to any associated equipment or products and will not be liable for loss of profit, labor, or other damages. The obligation of this warranty is in lieu of all other warranties, expressed or implied, and no person or organization is authorized to assume any liability for Raven Industries.

Damages caused by normal wear and tear, misuse, abuse, neglect, accident, or improper installation and maintenance are not covered by this warranty.



Extended Warranty

What Does this Warranty Cover?

This warranty covers all defects in workmanship or materials in your Raven Applied Technology Division product under normal use, maintenance, and service when used for intended purpose.

Do I Need to Register My Product to Qualify for the Extended Warranty?

Yes. Products/systems must be registered within 30 days of retail sale to receive coverage under the Extended Warranty. If the component does not have a serial tag, the kit it came in must be registered instead.

Where Can I Register My Product for the Extended Warranty?

To register, go online to www.ravenhelp.com and select Product Registration.

How Long is the Extended Warranty Coverage Period?

Raven Applied Technology products that have been registered online are covered for an additional 12 months beyond the Limited Warranty for a total coverage period of 24 months from the date of retail sale. In no case will the Extended Warranty period exceed 36 months from the date the product was issued by Raven Industries Applied Technology Division. This Extended Warranty coverage applies only to the original owner and is non-transferable.

How Can I Get Service?

Bring the defective part and proof of purchase to your Raven dealer. If the dealer approves the warranty claim, the dealer will process the claim and send it to Raven Industries for final approval. The freight cost to Raven Industries will be the customer's responsibility. The Return Materials Authorization (RMA) number must appear on the box and all documentation (including proof of purchase) must be included inside the box to be sent to Raven Industries. In addition, the words "Extended Warranty" must appear on the box and all documentation if the failure is between 12 and 24 months from the retail sale.

What Will Raven Industries Do?

Upon confirmation of the product's registration for the Extended Warranty and the claim itself, Raven Industries will (at our discretion) repair or replace the defective product and pay for the standard return freight, regardless of the inbound shipping method. Expedited freight is available at the customer's expense.

What is Not Covered by the Extended Warranty?

Raven Industries will not assume any expense or liability for repairs made outside our facilities without written consent. Raven Industries is not responsible for damage to any associated equipment or products and will not be liable for loss of profit, labor, or other damages. Cables, hoses, software enhancements, and remanufactured items are not covered by this Extended Warranty. The obligation of this warranty is in lieu of all other warranties, expressed or implied, and no person or organization is authorized to assume any liability for Raven Industries.

Damages caused by normal wear and tear, misuse, abuse, neglect, accident, or improper installation and maintenance are not covered by this warranty.