

RAVEN

Simply improving your position.SM

AutoBoom™ Installation Manual



Miller Condor G-Series Mono Boom

Disclaimer

While every effort has been made to ensure the accuracy of this document, Raven Industries assumes no responsibility for omissions and errors. Nor is any liability assumed for damages resulting from the use of information contained herein.

Raven Industries shall not be held responsible or liable for the effects of atmospheric conditions and sunspot activity on the performance of our products. Raven Industries cannot guarantee the accuracy, integrity, continuity, or availability of the GPS signal from the U.S. Department of Defense/NAVSTAR GPS satellites, the OmniSTAR correction service, or the WAAS correction service. Raven Industries accepts no responsibility for the use of the signal for other than the stated purpose.

Raven Industries shall not be responsible or liable for incidental or consequential damages or a loss of anticipated benefits or profits, work stoppage or loss, or impairment of data arising out of the use, or inability to use, this system or any of its components.

Chapter 1	<i>Important Safety Information</i>	1
	Important Safety Information	1
	Hydraulic Safety	2
	Electrical Safety	2
Chapter 2	<i>Introduction</i>	3
	Introduction	3
	Recommendations	4
	Preparing for Installation	4
	Point of Reference	4
	Hydraulic Fittings	4
Chapter 3	<i>PowerGlide Plus</i>	5
	PowerGlide Plus Kit Contents	5
	Install the PowerGlide Plus Hydraulic System	8
	Remove the Orifice Fittings	9
	Install Fittings on the AutoBoom Valve	11
	Mount the AutoBoom Valve	12
	Install Left and Right Cylinder Hoses	14
	PowerGlide Plus Hydraulic Schematic	15
	Install the Gauge Wheels	16
	Gauge Wheel Mounting Locations	16
	Mount the Gauge Wheels	16
	Install the PowerGlide Plus Wiring	17
	Install the AutoBoom Node	17
	Connect the Harness - Power/CAN Connectors	18
	Connect the Harness to the Tilt and Center Rack Controls	19
	Connect the Harness to the AutoBoom Valve	19
Chapter 4	<i>UltraGlide</i>	21
	UltraGlide Kit Contents	21
	Install the UltraGlide Hydraulic System	25
	Install Fittings on the AutoBoom Valve	25
	Mount the AutoBoom Valve	26
	Install Left and Right Cylinder Hoses	28
	UltraGlide Hydraulic Schematic	29
	Install the UltraGlide Sensors	30
	Boom Sensor Mounting Locations	30
	Mount the UltraGlide Boom Sensors	30
	Mount the Center Rack Sensor	31
	Connect the Sensor Cables	31
	Install the Gauge Wheels - Optional	32

Gauge Wheel Mounting Locations	32
Mount the Gauge Wheels	32
Install the UltraGlide Wiring	33
Install the AutoBoom Node	33
Connect the Harness - Power/CAN Connectors	34
Connect the Harness to the Tilt and Center Rack Controls	35
Connect the Harness to the AutoBoom Valve	35
Connect the Harness Cable to the Sensors	35
Chapter 5 Replacement Parts	37
Valve Blocks	37
Wheels	38
Sensors	38

CHAPTER

1

Important Safety Information

Important Safety Information

NOTICE

Read this manual and the operation and safety instructions included with your implement and/or controller carefully before installing the AutoBoom™ system.

- Follow all safety information presented within this manual.
- If you require assistance with any portion of the installation or service of your Raven equipment, contact your local Raven dealer for support.
- Follow all safety labels affixed to the AutoBoom system components. Be sure to keep safety labels in good condition and replace any missing or damaged labels. To obtain replacements for missing or damaged safety labels, contact your local Raven dealer.

When operating the machine after installing AutoBoom, observe the following safety measures:

- Be alert and aware of surroundings.
- Do not operate AutoBoom or any agricultural equipment while under the influence of alcohol or an illegal substance.
- Remain in the operator's position in the machine at all times when AutoBoom is engaged.
- Disable AutoBoom when exiting from the operator's seat and machine.
- Do not drive the machine with AutoBoom enabled on any public road.
- Determine and remain a safe working distance from other individuals. The operator is responsible for disabling AutoBoom when the safe working distance has been diminished.
- Ensure AutoBoom is disabled prior to starting any maintenance work on AutoBoom or the machine.

WARNING

- When starting the machine for the first time after installing AutoBoom, be sure that all persons stand clear, in case a hose has not been properly tightened.
- The machine must remain stationary and switched off, with the booms unfolded and supported while installation or maintenance is conducted.

CAUTION

Hydraulic Safety

- Raven Industries recommends that appropriate protective equipment be worn at all times when working on the hydraulic system.
- Never attempt to open or work on a hydraulic system with the equipment running. Care should always be taken when opening a system that has been previously pressurized.
- When disconnecting the hydraulic hoses or purging is required, be aware that the hydraulic fluid may be extremely hot and under high pressure. Caution must be exercised.
- Any work performed on the hydraulic system must be done in accordance with the machine manufacturer's approved maintenance instructions.
- When installing AutoBoom hydraulics or performing diagnostics, maintenance, or routine service, ensure that precautions are taken to prevent any foreign material or contaminants from being introduced into the machine's hydraulic system. Objects or materials that are able to bypass the machine's hydraulic filtration system will adversely reduce performance and possibly damage the AutoBoom hydraulic valves.

Electrical Safety

- Always verify that the power leads are connected to the correct polarity as marked. Reversing the power leads could cause severe damage to the equipment.
- Ensure that the power cable is the last cable to be connected.

CHAPTER

2

Introduction

Introduction

Congratulations on your purchase of the Raven AutoBoom system! This system is designed to provide automated boom height adjustment for agricultural equipment.

This manual applies to the following machines. For future reference, write your serial number in the space below.

MAKE: Miller Condor

MODEL: G-Series Mono Boom

YEAR:

SERIAL NUMBER:

FIGURE 1. Miller Condor G-Series Mono Boom



Note: *This manual contains the installation instructions for the PowerGlide Plus and UltraGlide systems. Be sure to identify which system you have and follow only the instructions for that system.*

Recommendations

Raven Industries recommends the following best practices when installing the AutoBoom system:

- Use part numbers to identify the parts.
- Do not remove the plastic wrap from a part until it is necessary for installation.
- Do not remove plastic caps from a part until it is necessary for installation.

Tools Needed

The following tools are recommended for installation of the AutoBoom system:

- SAE standard-sized wrenches
- Cable ties
- Set of tools

Preparing for Installation

Before installing AutoBoom, park the machine where the ground is level, clean, and dry. Leave the machine turned off for the duration of the installation process.

During the installation process, follow good safety practices. Be sure to carefully read the instructions in this manual as you complete the installation process.

Point of Reference

The instructions in this manual assume that you are standing behind the machine, looking toward the cab.

Hydraulic Fittings

This manual may reference the following types of hydraulic fittings:

- SAE O-ring fittings
- ORFS (O-Ring Face Seal) fittings
- JIC fittings

SAE O-ring fitting



ORFS fitting



JIC fitting (M)



PowerGlide Plus Kit Contents

This section contains a list of the components that are included in the PowerGlide Plus AutoBoom kit. Before beginning the AutoBoom installation, compare the items in the AutoBoom kit with the components on this list. If you have questions about the kit, contact your Raven dealer.

TABLE 1. PowerGlide Plus Installation Kit (P/N 117-0231-094)





Picture	Item Description	Part Number	Qty.
Not Pictured	Manual - Miller Condor G-Series Mono Boom AutoBoom Installation	016-0230-094	1
Not Pictured	Manual - CAN AutoBoom Calibration & Operation	016-0130-062	1
	Valve - PowerGlide Plus AutoBoom	063-0131-124	1
	Plate - Hydraulic Block Mounting	107-0171-619	1
	AutoBoom PowerGlide Plus CAN Node	063-0130-010	1
	Cable - Miller Condor G-Series AutoBoom	115-0230-076	1

TABLE 1. PowerGlide Plus Installation Kit (P/N 117-0231-094)

Picture	Item Description	Part Number	Qty.
	U-Bolt - 3-1/16" W x 4" L x 3/8" Thread	107-0171-608	2
	Bolt - 5/16"-18 x 7/8" Grade 8 Hex	311-0052-104	4
	Bolt - 1/4"-20 x 1" Hex	311-0050-105	3
	Nut - 3/8"-16 Zinc Flanged Lock	312-1001-164	4
	Nut - 1/4"-20 Nylon Lock	312-4000-057	3
	Washer - 5/16" Zinc Plated Lock	313-1000-019	4
	Washer - 1/4" Flat	313-2300-009	6

TABLE 2. Hydraulic Kit (P/N 117-0134-077)



Picture	Item Description	Part Number	Qty.
	Fitting - 3/4" ORFS M/M/F Swivel Run Tee Adapter	333-0012-028	4
	Fitting - 3/4" ORFS (M) to 9/16" SAE O-Ring (M) Straight Adapter	333-0012-082	2
	Fitting - 11/16" Hex 9/16" SAE O-Ring (M)	333-0012-194	2

TABLE 2. Hydraulic Kit (P/N 117-0134-077)







Picture	Item Description	Part Number	Qty.
	Fitting - 3/4" ORFS (M) to 3/4" SAE O-Ring (M) 90° Elbow	333-0012-229	2
	Hydraulic Hose - 3/4" ORFS to 3/4" ORFS - 40"	214-1000-529	4

TABLE 3. PowerGlide Plus Wheel Kit (P/N 117-0133-004)

Picture	Item Description	Part Number	Qty.
	Axle Assembly - Right Cushioned AutoBoom	063-0131-585	1
	Axle Assembly - Left Cushioned AutoBoom	063-0131-590	1
	Bracket - Nitro Weldment	116-0159-542	2
	Bracket - Hub Retainer	107-0171-617	2
	Wheel	322-0131-008	2
	U-Bolt - 5-1/16" x 6" L x 7/16" Thread	107-0171-603	4
	U-Bolt - 4-1/16" W x 5" L x 7/16" Thread	107-0171-604	4
	U-Bolt - 3-1/16" W x 4" L x 3/8" Thread	107-0171-608	4

TABLE 3. PowerGlide Plus Wheel Kit (P/N 117-0133-004)

Picture	Item Description	Part Number	Qty.
	Bolt - 1/2"-13 x 1-1/2" SS Hex	311-0058-186	4
	Nut - 1/2"-13 Zinc Hex	312-1001-043	4
	Nut - 3/8"-16 Zinc Flanged Lock	312-1001-164	8
	Nut - 7/16"-16 Zinc Flanged Lock	312-1001-165	8

Install the PowerGlide Plus Hydraulic System



⚠ WARNING

The machine must remain stationary and switched off, with the booms unfolded and supported, during installation or maintenance.



⚠ CAUTION

When installing AutoBoom hydraulics or performing diagnostics, maintenance, or routine service, ensure precautions are taken to prevent any foreign material from being introduced into the machine's hydraulic system.

Objects or materials that are able to bypass the machine's hydraulic filtration system will reduce performance and possibly cause damage to the AutoBoom hydraulic valve.

	<p>NOTICE</p> <p>The appearance of the AutoBoom hydraulic valve may vary slightly from the images contained in this manual. However, the fittings, hose connections, and cable connections remain the same.</p>
---	--

Remove the Orifice Fittings

Before populating the hydraulic fittings on the AutoBoom valve, it is necessary to remove orifice fittings from the valve in the PowerGlide Plus system. Failure to remove these fittings from the valve will restrict the down speed of the booms when the system is enabled.

FIGURE 1. Port 3A and 3B Location



1. Locate Ports 3A and 3B on the AutoBoom valve (P/N 063-0131-124).

FIGURE 2. Coil Removed from the AutoBoom Valve



2. Remove the coils from the solenoids near Ports 3A and 3B to gain easy access to those ports.

FIGURE 3. Port Plugs Removed from the AutoBoom Valve



3. Use an Allen wrench to remove the plugs from Ports 3A and 3B.

FIGURE 4. Orifice Fitting Removed from the AutoBoom Valve

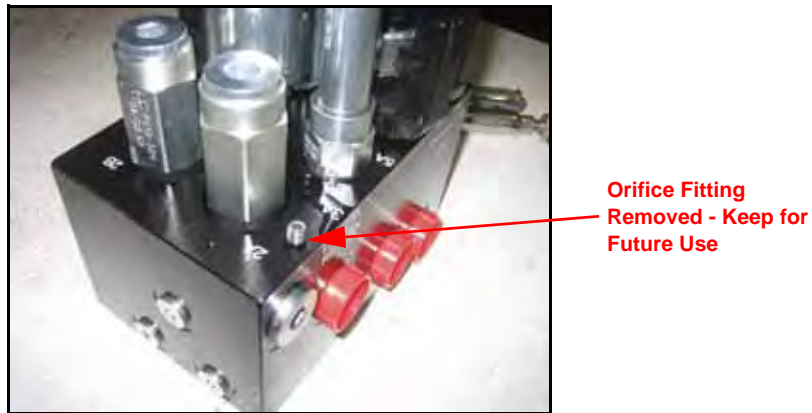

4. Remove the orifice fittings from Ports 3A and 3B.

Important: *Tip the AutoBoom valve on its side and use the Allen wrench to remove the orifice from the cavity, taking care not to let the fitting fall into the valve.*

FIGURE 5. Port Plug Reinstalled on the AutoBoom Valve



- Use the Allen wrench to reinstall the port plugs on Ports 3A and 3B of the AutoBoom valve.

FIGURE 6. Coil Reinstalled on the AutoBoom Valve



- Reinstall the coils on the solenoids of the AutoBoom valve.

Install Fittings on the AutoBoom Valve

Before mounting the AutoBoom valve on the machine, install the proper fittings in the valve. This prepares the valve for installation and simplifies the hose connection process later in the procedure.

⚠ WARNING

The machine must remain stationary and switched off, with the booms unfolded and supported, during installation or maintenance.

Refer to the following table to install the fittings in the appropriate ports of the AutoBoom valve.

Fitting	Part Number	Port
Fitting - 13/16" ORFS (M) to 9/16" SAE O-Ring (M) Straight Adapter	333-0012-082	LC, RC
Fitting - 13/16" ORFS (M) to 3/4" SAE O-Ring (M) 90° Elbow	333-0012-229	P, T
Fitting - 11/16" Hex 9/16" SAE O-Ring (M)	333-0012-194	LV, RV

Mount the AutoBoom Valve

FIGURE 7. AutoBoom Valve Mounted on Valve Mounting Plate

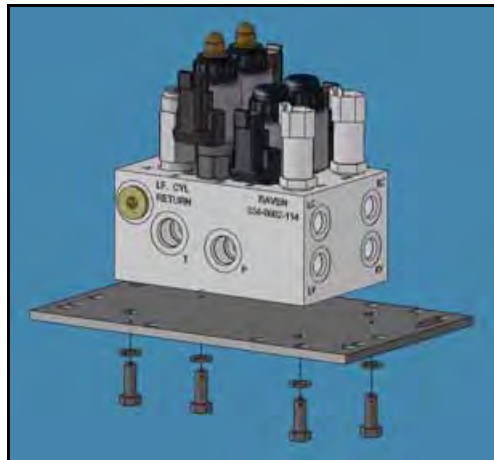

1. Secure the PowerGlide Plus AutoBoom valve (P/N 063-0131-124) to the mounting plate (P/N 107-0171-619) using four 5/16" hex bolts (P/N 311-0052-104) and four 5/16" lock washers (P/N 313-1000-019).

FIGURE 8. AutoBoom Valve Mounted on the Sprayer

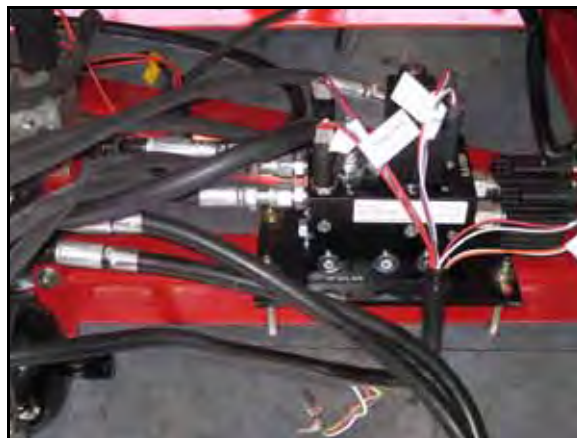

2. Secure the mounting plate on the center rack using two 4" W x 5" L x 3/8" thread U-bolts (P/N 107-0171-606) and four 3/8"-16 zinc flanged lock nuts (P/N 312-1001-164).

Important: Mount the AutoBoom valve as close to the machine's accumulator valve (with Ports LC and RC facing the accumulator) as possible to ensure the AutoBoom valve clears the center rack upright when the center rack is completely lowered to the ground.

Install the Pressure and Tank Hoses



⚠ WARNING

Hydraulics are under pressure. Care should always be taken with a system that has been pressurized. When disconnecting or purging hydraulic hoses, be aware that the hydraulic fluid within the machine's system may be extremely hot and under high pressure.



⚠ CAUTION

When installing AutoBoom hydraulics or performing diagnostics, maintenance, or routine service, ensure precautions are taken to prevent any foreign material or contaminants from being introduced into the machine's hydraulic system.

Objects or materials that are able to bypass the machine's hydraulic filtration system will reduce performance and possibly cause damage to the AutoBoom hydraulic valves.

FIGURE 9. Pressure and Tank Hoses Installed

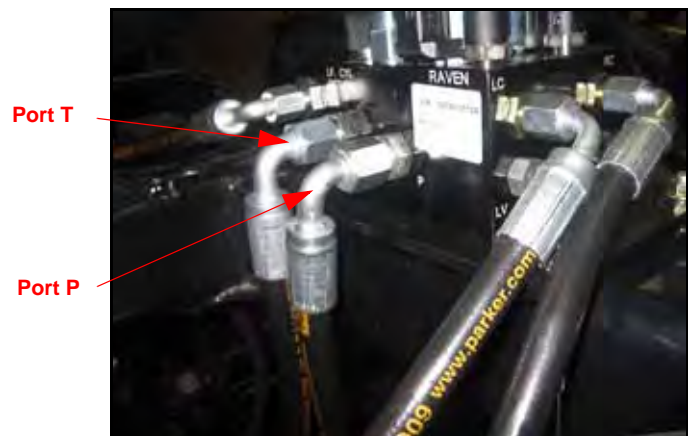
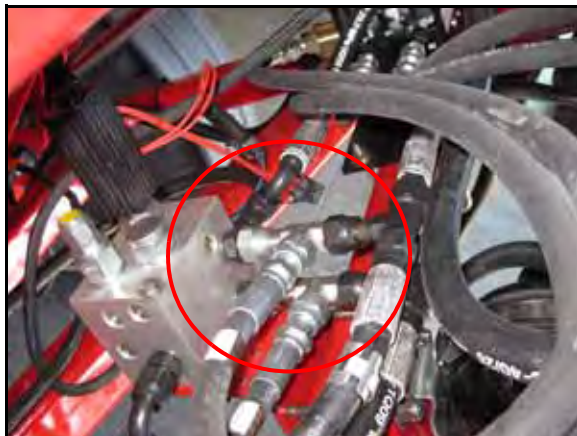

1. Disconnect the machine's pressure lines from the machine's hydraulic valve by disconnecting the machine's tee fitting from the hydraulic valve.
2. Install a 13/16" ORFS M/M/F swivel run tee adapter fitting (P/N 333-0012-028) in the machine's pressure port.
3. Attach the machine's tee fitting to the opposite end of the installed tee fitting.
4. Connect one end of the supplied hydraulic hose (P/N 214-1000-529) to the 90° end of the installed tee fitting.
5. Connect the other end of the hydraulic hose to the installed fitting in Port P on the AutoBoom valve.
6. Disconnect the machine's tank lines from the machine's hydraulic valve by disconnecting the machine's tee fitting from the hydraulic valve.

7. Install a 13/16" ORFS M/M/F swivel run tee adapter fitting (P/N 333-0012-028) in the machine's tank port.
8. Attach the machine's tee fitting to the opposite end of the installed tee fitting.
9. Connect one end of the supplied hydraulic hose (P/N 214-1000-529) to the 90° end of the installed tee fitting.
10. Connect the other end of the hydraulic hose to the installed fitting in Port T on the AutoBoom valve.

Install Left and Right Cylinder Hoses

FIGURE 10. Left and Right Cylinder Hoses Installed



1. Disconnect the machine's left and right tilt lines from the machine's hydraulic valve.
2. Install 13/16" ORFS (M) to 9/16" SAE O-ring (M) swivel run tee adapter fittings (P/N 333-0012-028) in the L Up and R Up ports of the machine's hydraulic valve.

Note: *Align the tee fittings so that the 90° ends of the fittings point toward the front of the machine.*

3. Connect the machine's left tilt line to the opposite end of the installed tee fitting in the L Up port.
4. Install one end of the supplied hydraulic hose (P/N 214-1000-529) on the 90° end of the installed tee fitting.
5. Connect the other end of the hydraulic hose to the installed fitting in Port LC on the AutoBoom valve.
6. Connect the machine's right tilt line to the opposite end of the installed tee fitting in the R Up port.
7. Install one end of the supplied hydraulic hose (P/N 214-1000-529) on the 90° end of the installed tee fitting.
8. Connect the other end of the hydraulic hose to the installed fitting in Port RC on the AutoBoom valve.

PowerGlide Plus Hydraulic Schematic

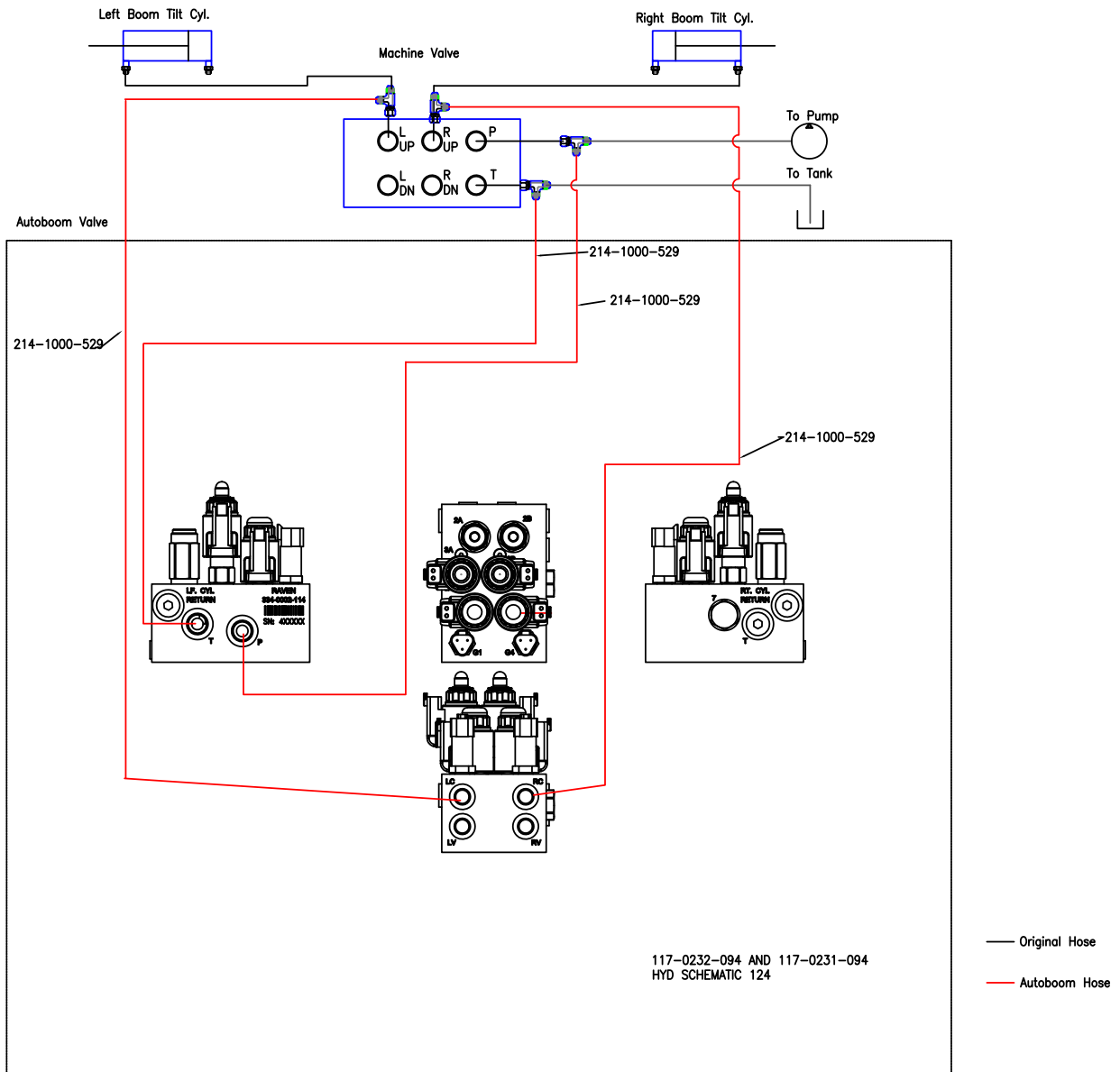

Install the Gauge Wheels

Gauge Wheel Mounting Locations

Wheel mounting locations may be influenced by the boom configuration. Determine the appropriate location for mounting the wheels on the boom, ensuring the wheels will not interfere with or be damaged while folding or unfolding the booms. The wheels should be mounted outside of the boom fold, but inside of the boom breakaway.

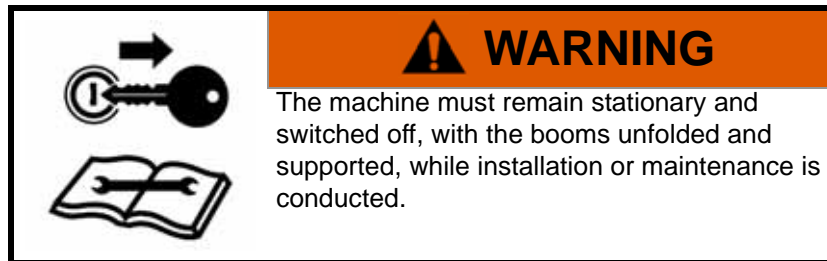

Mount the Gauge Wheels

Note: The appearance of the wheel axles may vary.

FIGURE 11. Gauge Wheel Installed



1. Remove the nuts from the left wheel axle (P/N 063-0131-590).
2. Place the wheel (P/N 322-0131-008) on the left wheel axle.
3. Align and place the hub retainer bracket (P/N 107-0171-617) over the wheel.
4. Reinstall the lug nuts on the wheel axle to secure the wheel and hub retainer bracket.
5. Mount the left wheel receiver bracket (P/N 116-0159-542) to the front of the left boom using two U-bolts (P/N 107-0171-603, 107-0171-604, or 107-0171-608) and four nuts (P/N 312-1001-164 or 312-1001-165) appropriate for the size of the machine's booms.
6. Insert the left wheel axle into the left wheel receiver bracket, positioning it so that the bottom of the wheel touches the ground (or nearly so).
7. Secure the gauge wheel assembly in the wheel mounting bracket by installing two 1/2"-13 x 1-1/2" SS hex bolts (P/N 311-0058-186) and two 1/2" zinc hex nuts (P/N 312-1001-043).
8. Repeat the steps above to install the right wheel.

Install the PowerGlide Plus Wiring

Wiring Connections

	<p>⚠ CAUTION</p> <p>Always connect the power cable as the last step in the wiring process and verify that the power leads are connected with the correct polarity. Reversing power leads can cause severe damage to the equipment.</p>
---	---

Note: For wiring connections made outside the cab, apply dielectric silicone grease (P/N 222-0000-006) generously on both the male and female ends of the connectors. Application of the grease will prevent corrosion to the pins and wires.

Install the AutoBoom Node

1. Locate the node enclosure along the right rear chassis frame rail, beneath the product tank and the open cover.

FIGURE 12. AutoBoom Node Mounting Location

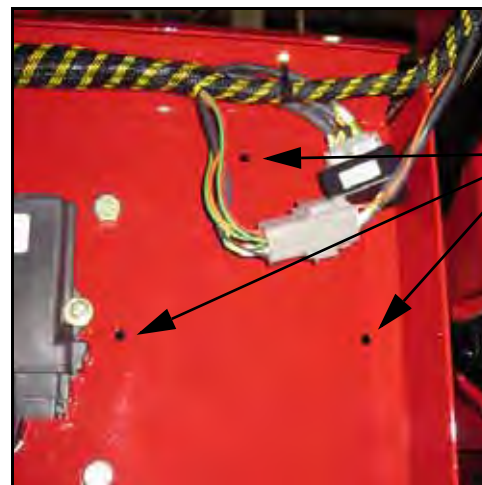

Node Mounting Holes on
Node Mounting Enclosure

2. Locate the node mounting holes in the rear of the node mounting enclosure.

FIGURE 13. AutoBoom Node Installed



3. Install the AutoBoom node (P/N 063-0130-010) on the node mounting enclosure holes using three 1/4"-20 hex bolts (P/N 311-0050-105), six 1/4" flat washers (P/N 313-2300-009), and three 1/4" nylon lock nuts (P/N 312-4000-057).
4. Insert the large, rectangular node connectors on the harness cable (P/N 115-0230-076) into the left and right ports of the AutoBoom node.
5. Tighten the bolts on the node connectors to secure the connection.

Connect the Harness - Power/CAN Connectors

1. Locate the 8-pin Deutsch connectors labeled CD09 and CD10 on the machine's harness cable.
2. Disconnect the connectors.

FIGURE 14. AutoBoom Harness Connected to the Machine's Harness



3. Connect the harness cable (P/N 115-0230-076) 8-pin Deutsch connectors to the machine's CD09 and CD10 connectors.

Connect the Harness to the Tilt and Center Rack Controls

FIGURE 15. Boom Function Wiring



1. Locate and disconnect the machine's 6-pin Deutsch connectors above the node enclosure, along the right rear chassis frame rail.
2. Locate the 6-pin Deutsch connectors on the AutoBoom harness cable (P/N 115-0230-076).
3. Route the AutoBoom harness cable connectors to the machine's 6-pin connectors.
4. Connect the harness cable's 6-pin connectors to the machine's connectors.

Connect the Harness to the AutoBoom Valve

1. Locate the Left Press and Right Press connectors on the AutoBoom harness cable (P/N 115-0230-076).
2. Route the connectors to the AutoBoom valve (P/N 063-0131-124).
3. Connect the Left Press connector to Port G1 on the AutoBoom valve.
4. Connect the Right Press connector to Port G4 on the AutoBoom valve.
5. Locate the Left Solenoid and Right Solenoid connectors on the harness cable.
6. Connect the Left Solenoid connector to Port 4A on the AutoBoom valve.
7. Connect the Right Solenoid connector to Port 4B on the AutoBoom valve.
8. Locate the Left Prop and Right Prop connectors on the harness cable.
9. Connect the Left Prop connector to Port 5A on the AutoBoom valve.
10. Connect the Right Prop connector to Port 13A on the AutoBoom valve.
11. Secure the harness cable and unused connections with plastic ties, allowing enough slack in the harness cable to allow for boom racking.

CHAPTER

4

UltraGlide

UltraGlide Kit Contents

This section contains a list of the components that are included in the UltraGlide AutoBoom kit. Before beginning the AutoBoom installation, compare the items in the AutoBoom kit with the components on this list. If you have questions about the kit, contact your Raven dealer.

TABLE 1. UltraGlide Installation Kit (P/N 117-0232-094)





Picture	Item Description	Part Number	Qty.
Not Pictured	Manual - Miller Condor G-Series Mono Boom AutoBoom Installation	016-0230-094	1
Not Pictured	Manual - CAN AutoBoom Calibration & Operation	016-0130-062	1
	Valve - PowerGlide Plus AutoBoom	063-0131-124	1
	Plate - Hydraulic Block Mounting	107-0171-619	1
	Node - UltraGlide AutoBoom CAN	063-0130-013	1
	Sensor - Right Ultrasonic	063-0130-012	1

TABLE 1. UltraGlide Installation Kit (P/N 117-0232-094)

Picture	Item Description	Part Number	Qty.
	Sensor - Left Ultrasonic	063-0130-014	1
	Sensor - Center Ultrasonic	063-0130-018	1
	Bracket - Nitro Sensor	116-0159-619	2
	Cable - Miller Condor G-Series AutoBoom	115-0230-076	1
	Cable - 60' Extension Ultrasonic Sensor	115-0230-051	2
	U-Bolt - 3-1/16" W x 4" L x 3/8" Thread	107-0171-608	4
	Clamp - 1-1/2" W x 2-1/2" L x 3/8" Thread U-Bolt	435-3003-047	2
	Bolt - 5/16"-18 x 7/8" Grade 8 Hex	311-0052-104	4
	Bolt - 1/4"-20 x 1" Hex	311-0050-105	3
	Bolt - 3/8"-16 UNC x 1" Hex	311-0054-105	8
	Nut - 3/8"-16 Zinc Flanged Lock	312-1001-164	16

TABLE 1. UltraGlide Installation Kit (P/N 117-0232-094)



Picture	Item Description	Part Number	Qty.
	Nut - 1/4"-20 Nylon Lock	312-4000-057	3
	Washer - 5/16" Zinc Plated Lock	313-1000-019	4
	Washer - 1/4" Flat	313-2300-009	6

TABLE 2. Hydraulic Kit (P/N 117-0134-077)

Picture	Item Description	Part Number	Qty.
	Fitting - 3/4" ORFS M/M/F Swivel Run Tee Adapter	333-0012-028	4
	Fitting - 3/4" ORFS (M) to 9/16" SAE O-Ring (M) Straight Adapter	333-0012-082	2
	Fitting - 11/16" Hex 9/16" SAE O-Ring (M)	333-0012-194	2
	Fitting - 3/4" ORFS (M) to 3/4" SAE O-Ring (M) 90° Elbow	333-0012-229	2
	Hydraulic Hose - 3/4" ORFS to 3/4" ORFS - 40"	214-1000-529	4

TABLE 3. Optional Wheel Kit (P/N 117-0133-004)







Picture	Item Description	Part Number	Qty.
	Axle Assembly - Right Cushioned AutoBoom	063-0131-585	1
	Axle Assembly - Left Cushioned AutoBoom	063-0131-590	1
	Bracket - Nitro Weldment	116-0159-542	2
	Bracket - Hub Retainer	107-0171-617	2
	Wheel	322-0131-008	2
	U-Bolt - 5-1/16" x 6" L x 7/16" Thread	107-0171-603	4
	U-Bolt - 4-1/16" W x 5" L x 7/16" Thread	107-0171-604	4
	U-Bolt - 3-1/16" W x 4" L x 3/8" Thread	107-0171-608	4
	Bolt - 1/2"-13 x 1-1/2" SS Hex	311-0058-186	4
	Nut - 1/2"-13 Zinc Hex	312-1001-043	4

TABLE 3. Optional Wheel Kit (P/N 117-0133-004)

Picture	Item Description	Part Number	Qty.
	Nut - 3/8"-16 Zinc Flanged Lock	312-1001-164	8
	Nut - 7/16"-16 Zinc Flanged Lock	312-1001-165	8

Install the UltraGlide Hydraulic System

Install Fittings on the AutoBoom Valve

Before mounting the AutoBoom valve on the machine, install the proper fittings in the valve. This prepares the valve for installation and simplifies the hose connection process later in the procedure.



⚠ WARNING

The machine must remain stationary and switched off, with the booms unfolded and supported, during installation or maintenance.

Refer to the following table to install the fittings in the appropriate ports of the AutoBoom valve.

Fitting	Part Number	Port
Fitting - 13/16" ORFS (M) to 9/16" SAE O-Ring (M) Straight Adapter	333-0012-082	LC, RC
Fitting - 13/16" ORFS (M) to 3/4" SAE O-Ring (M) 90° Elbow	333-0012-229	P, T
Fitting - 11/16" Hex 9/16" SAE O-Ring (M)	333-0012-194	LV, RV

Mount the AutoBoom Valve

FIGURE 1. AutoBoom Valve Mounted on Valve Mounting Plate

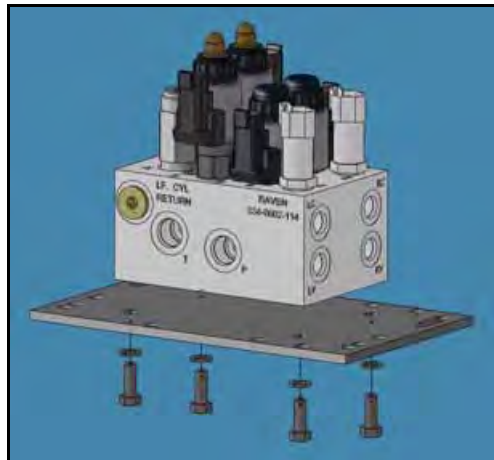

1. Secure the PowerGlide Plus AutoBoom valve (P/N 063-0131-124) to the mounting plate (P/N 107-0171-619) using four 5/16" hex bolts (P/N 311-0052-104) and four 5/16" lock washers (P/N 313-1000-019).

FIGURE 2. AutoBoom Valve Mounted on the Sprayer

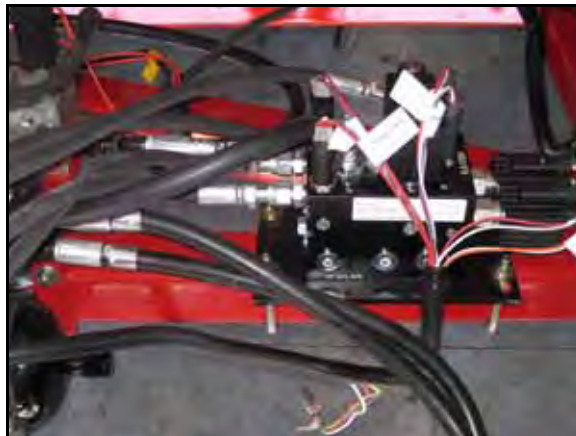

2. Secure the mounting plate on the center rack using two 4" W x 5" L x 3/8" thread U-bolts (P/N 107-0171-606) and four 3/8"-16 zinc flanged lock nuts (P/N 312-1001-164).

Important: Mount the AutoBoom valve as close to the machine's accumulator valve (with Ports LC and RC facing the accumulator) as possible to ensure the AutoBoom valve clears the center rack upright when the center rack is completely lowered to the ground.

Install the Pressure and Tank Hoses



⚠ WARNING

Hydraulics are under pressure. Care should always be taken with a system that has been pressurized. When disconnecting or purging hydraulic hoses, be aware that the hydraulic fluid within the machine's system may be extremely hot and under high pressure.



⚠ CAUTION

When installing AutoBoom hydraulics or performing diagnostics, maintenance, or routine service, ensure precautions are taken to prevent any foreign material or contaminants from being introduced into the machine's hydraulic system.

Objects or materials that are able to bypass the machine's hydraulic filtration system will reduce performance and possibly cause damage to the AutoBoom hydraulic valves.

FIGURE 3. Pressure and Tank Hoses Installed



1. Disconnect the machine's pressure lines from the machine's hydraulic valve by disconnecting the machine's tee fitting from the hydraulic valve.
2. Install a 13/16" ORFS M/M/F swivel run tee adapter fitting (P/N 333-0012-028) in the machine's pressure port.
3. Attach the machine's tee fitting to the opposite end of the installed tee fitting.
4. Connect one end of the supplied hydraulic hose (P/N 214-1000-529) to the 90° end of the installed tee fitting.
5. Connect the other end of the hydraulic hose to the installed fitting in Port P on the AutoBoom valve.
6. Disconnect the machine's tank lines from the machine's hydraulic valve by disconnecting the machine's tee fitting from the hydraulic valve.

7. Install a 13/16" ORFS M/M/F swivel run tee adapter fitting (P/N 333-0012-028) in the machine's tank port.
8. Attach the machine's tee fitting to the opposite end of the installed tee fitting.
9. Connect one end of the supplied hydraulic hose (P/N 214-1000-529) to the 90° end of the installed tee fitting.
10. Connect the other end of the hydraulic hose to the installed fitting in Port T on the AutoBoom valve.

Install Left and Right Cylinder Hoses

FIGURE 4. Left and Right Cylinder Hoses Installed



1. Disconnect the machine's left and right tilt lines from the machine's hydraulic valve.
2. Install 13/16" ORFS (M) to 9/16" SAE O-ring (M) swivel run tee adapter fittings (P/N 333-0012-028) in the L Up and R Up ports of the machine's hydraulic valve.

Note: *Align the tee fittings so that the 90° ends of the fittings point toward the front of the machine.*

3. Connect the machine's left tilt line to the opposite end of the installed tee fitting in the L Up port.
4. Install one end of the supplied hydraulic hose (P/N 214-1000-529) on the 90° end of the installed tee fitting.
5. Connect the other end of the hydraulic hose to the installed fitting in Port LC on the AutoBoom valve.
6. Connect the machine's right tilt line to the opposite end of the installed tee fitting in the R Up port.
7. Install one end of the supplied hydraulic hose (P/N 214-1000-529) on the 90° end of the installed tee fitting.
8. Connect the other end of the hydraulic hose to the installed fitting in Port RC on the AutoBoom valve.

UltraGlide Hydraulic Schematic

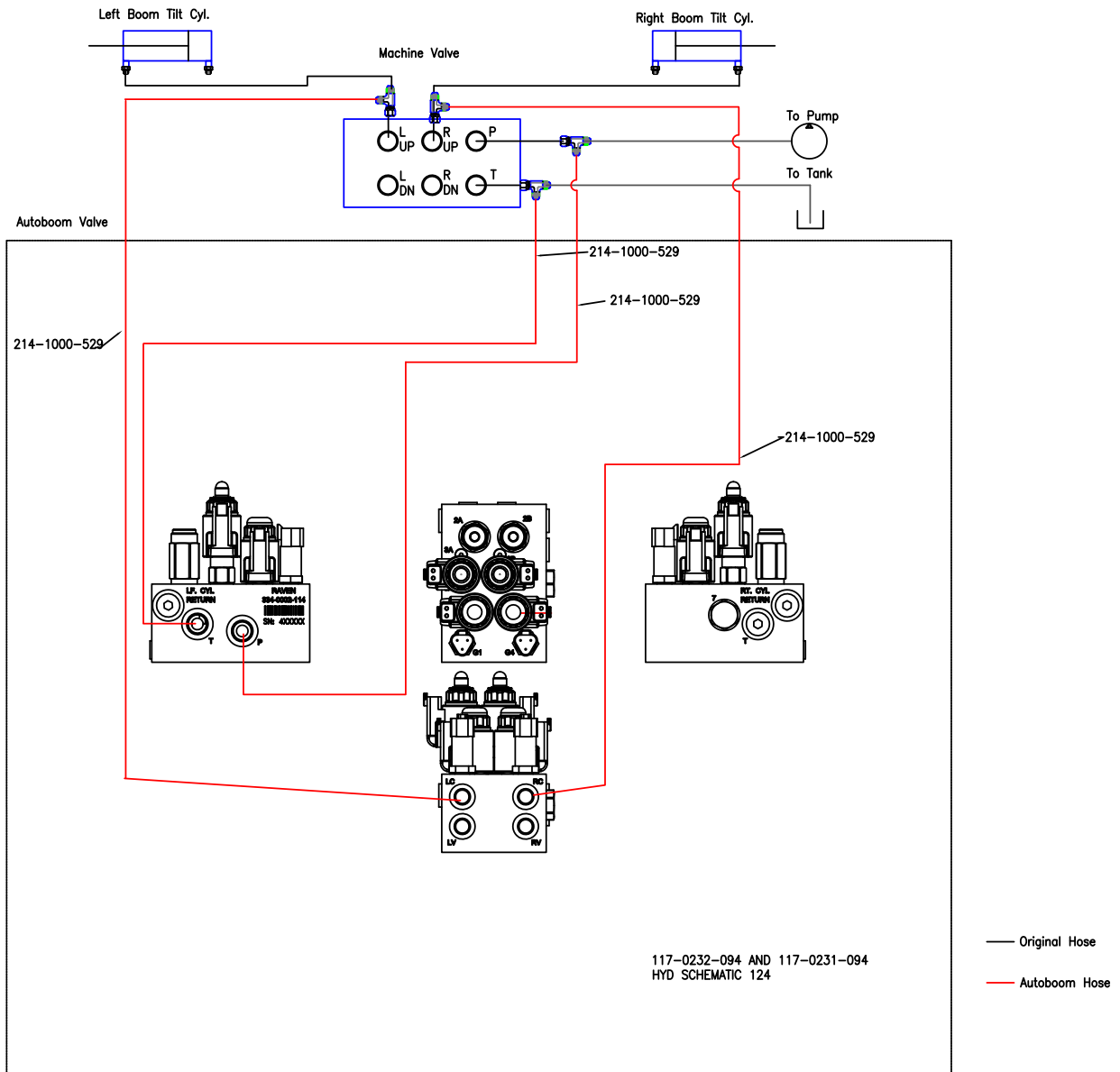

Install the UltraGlide Sensors

Boom Sensor Mounting Locations

Sensor mounting locations may be influenced by the boom configuration. Determine the appropriate location for mounting sensors on the boom, ensuring the sensors will not interfere with or be damaged by folding or unfolding the booms. The sensor should be mounted outside of the boom fold, but inside of the boom breakaway.

Note: When mounting two sensors per boom, the inside sensor must be turned sideways to prevent the sensors from interfering when folding the booms.

Mount the UltraGlide Boom Sensors

FIGURE 5. Boom Sensor Mounting Location



1. Secure the right sensor (P/N 063-0130-012) to the sensor bracket assembly (P/N 116-0159-619) using four 3/8"-24 x 3/4" grade 8 hex bolts (P/N 311-0054-105) and four 3/8"-16 zinc flanged lock nuts (P/N 312-1001-164).
2. Mount the left sensor to the front of the left boom using one 3-1/16" W x 4" L x 3/8" thread U-bolt (P/N 107-0171-608) and two 3/8" zinc flanged lock nuts (P/N 312-1001-164).
3. Tighten the nuts to ensure the sensor is mounted securely.
4. Repeat the steps above to install the right sensor.

Mount the Center Rack Sensor

FIGURE 6. Center Sensor Mounted (Rear View)

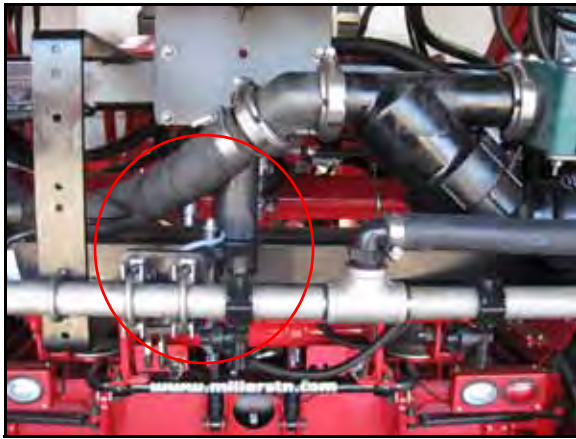

Note: It may be necessary to remove the bolt in the sensor's arm and flip the arm so that it curves upward.

1. Mount the center sensor (P/N 063-0130-018) to the machine's center rack spray tube using two 1-1/2" W x 2-1/2" L x 3/8" thread U-bolts (P/N 435-3003-047).
2. Tighten the nuts to ensure the sensor is mounted securely.

Connect the Sensor Cables

1. Connect the left sensor cable (P/N 115-0230-051) to the connector on the left sensor.
2. Route the left sensor cable toward the AutoBoom valve.
3. Loop and tie-off any excess cable, allowing enough cable for boom folding and extension.
4. Repeat the steps above to connect the remaining sensor cable(s).

Note: The sensor cables will be connected to the AutoBoom system in the wiring phase of installation.

Install the Gauge Wheels - Optional

Gauge Wheel Mounting Locations

Wheel mounting locations may be influenced by the boom configuration. Determine the appropriate location for mounting the wheels on the boom, ensuring the wheels will not interfere with or be damaged while folding or unfolding the booms. The wheels should be mounted outside of the boom fold, but inside of the boom breakaway.

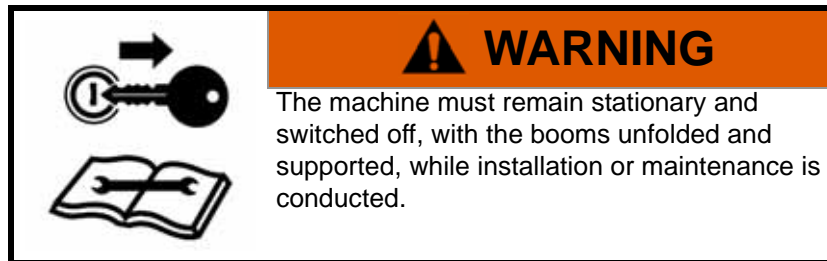

Mount the Gauge Wheels

Note: The appearance of the wheel axles may vary.

FIGURE 7. Gauge Wheel Installed



1. Remove the nuts from the left wheel axle (P/N 063-0131-590).
2. Place the wheel (P/N 322-0131-008) on the left wheel axle.
3. Align and place the hub retainer bracket (P/N 107-0171-617) over the wheel.
4. Reinstall the lug nuts on the wheel axle to secure the wheel and hub retainer bracket.
5. Mount the left wheel receiver bracket (P/N 116-0159-542) to the front of the left boom using two U-bolts (P/N 107-0171-603, 107-0171-604, or 107-0171-608) and four nuts (P/N 312-1001-164 or 312-1001-165) appropriate for the size of the machine's booms.
6. Insert the left wheel axle into the left wheel receiver bracket, positioning it so that the bottom of the wheel touches the ground (or nearly so).
7. Secure the gauge wheel assembly in the wheel mounting bracket by installing two 1/2"-13 x 1-1/2" SS hex bolts (P/N 311-0058-186) and two 1/2" zinc hex nuts (P/N 312-1001-043).
8. Repeat the steps above to install the right wheel.

Install the UltraGlide Wiring

Wiring Connections

	<p>⚠ CAUTION</p> <p>Always connect the power cable as the last step in the wiring process and verify that the power leads are connected with the correct polarity. Reversing power leads can cause severe damage to the equipment.</p>
---	---

Note: For wiring connections made outside the cab, apply dielectric silicone grease (P/N 222-0000-006) generously on both the male and female ends of the connectors. Application of the grease will prevent corrosion to the pins and wires.

Install the AutoBoom Node

1. Locate the node enclosure along the right rear chassis frame rail, beneath the product tank and the open cover.

FIGURE 8. AutoBoom Node Mounting Location

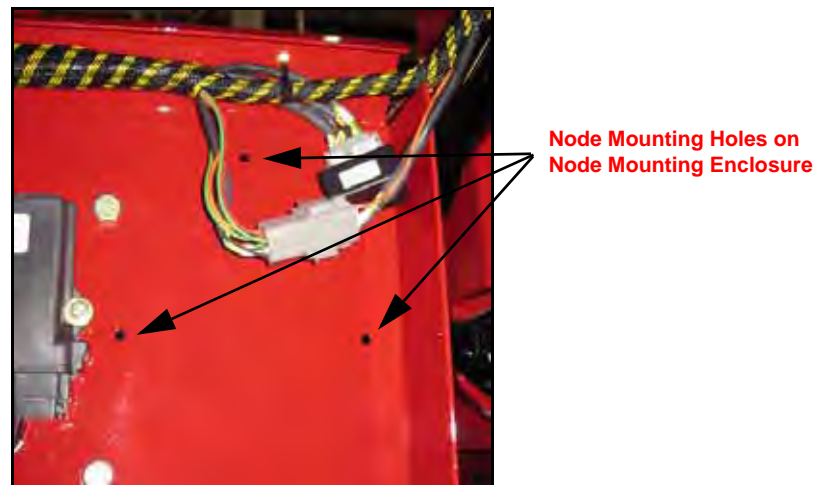

2. Locate the node mounting holes in the rear of the node mounting enclosure.

FIGURE 9. AutoBoom Node Installed



3. Install the AutoBoom node (P/N 063-0130-013) on the node mounting enclosure holes using three 1/4"-20 hex bolts (P/N 311-0050-105), six 1/4" flat washers (P/N 313-2300-009), and three 1/4" nylon lock nuts (P/N 312-4000-057).
4. Insert the large, rectangular node connectors on the harness cable (P/N 115-0230-076) into the left and right ports of the AutoBoom node.
5. Tighten the bolts on the node connectors to secure the connection.

Connect the Harness - Power/CAN Connectors

1. Locate the 8-pin Deutsch connectors labeled CD09 and CD10 on the machine's harness cable.
2. Disconnect the connectors.

FIGURE 10. AutoBoom Harness Connected to the Machine's Harness



3. Connect the harness cable (P/N 115-0230-076) 8-pin Deutsch connectors to the machine's CD09 and CD10 connectors.

Connect the Harness to the Tilt and Center Rack Controls

FIGURE 11. Boom Function Wiring



1. Locate and disconnect the machine's 6-pin Deutsch connectors above the node enclosure, along the right rear chassis frame rail.
2. Locate the 6-pin Deutsch connectors on the AutoBoom harness cable (P/N 115-0230-076).
3. Route the AutoBoom harness cable connectors to the machine's 6-pin connectors.
4. Connect the harness cable's 6-pin connectors to the machine's connectors.

Connect the Harness to the AutoBoom Valve

1. Locate the Left Press and Right Press connectors on the AutoBoom harness cable (P/N 115-0230-076).
2. Route the connectors to the AutoBoom valve (P/N 063-0131-124).
3. Connect the Left Press connector to Port G1 on the AutoBoom valve.
4. Connect the Right Press connector to Port G4 on the AutoBoom valve.
5. Locate the Left Solenoid and Right Solenoid connectors on the harness cable.
6. Connect the Left Solenoid connector to Port 4A on the AutoBoom valve.
7. Connect the Right Solenoid connector to Port 4B on the AutoBoom valve.
8. Locate the Left Prop and Right Prop connectors on the harness cable.
9. Connect the Left Prop connector to Port 5A on the AutoBoom valve.
10. Connect the Right Prop connector to Port 13A on the AutoBoom valve.
11. Secure the harness cable and unused connections with plastic ties, allowing enough slack in the harness cable to allow for boom racking.

Connect the Harness Cable to the Sensors

1. Locate the Center Sensor connector on the AutoBoom harness cable.
2. Connect the Center Sensor connector to the installed center sensor (P/N 063-0130-018).
3. Locate the Left Outer Sensor connector on the AutoBoom harness cable.
4. Connect the Left Outer Sensor connector to the installed left sensor cable (P/N 115-0171-527).
5. Locate the Right Outer Sensor connector on the AutoBoom harness cable.
6. Connect the Right Outer Sensor connector to the installed right sensor cable.
7. If optional inside boom sensor sensors are installed, repeat the steps above to connect the sensors.

CHAPTER

5

Replacement Parts

This section contains replacement part diagrams for PowerGlide Plus and UltraGlide systems. Refer to these diagrams when calling to request replacement parts.

Valve Blocks

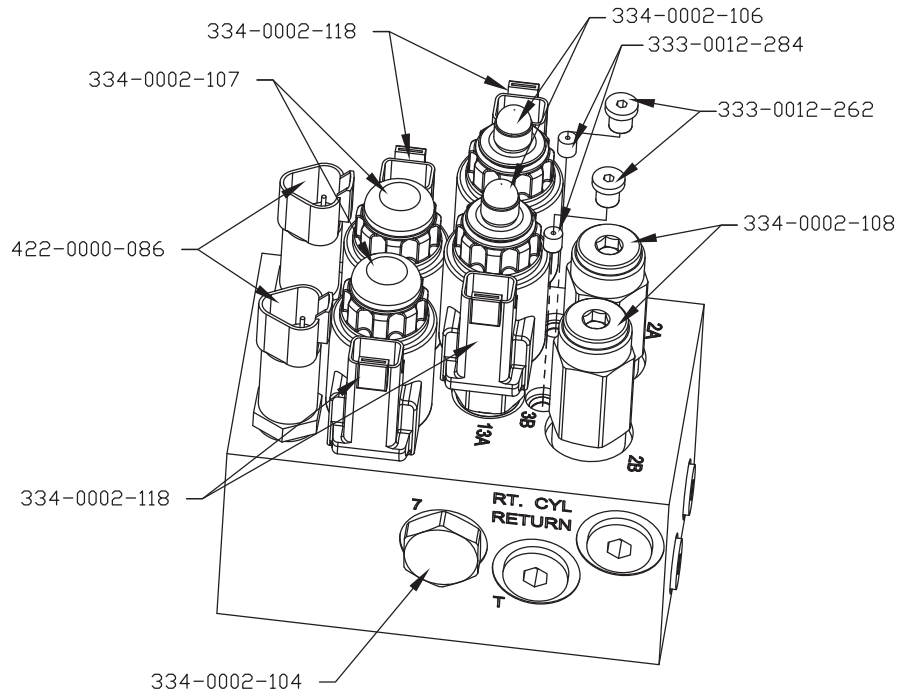

063-0131-124
VALVE, HYDRAULIC POWERGLIDE
PLUS/ULTRAGLIDE, CLOSED CENTER, AUTOBOOM

Wheels

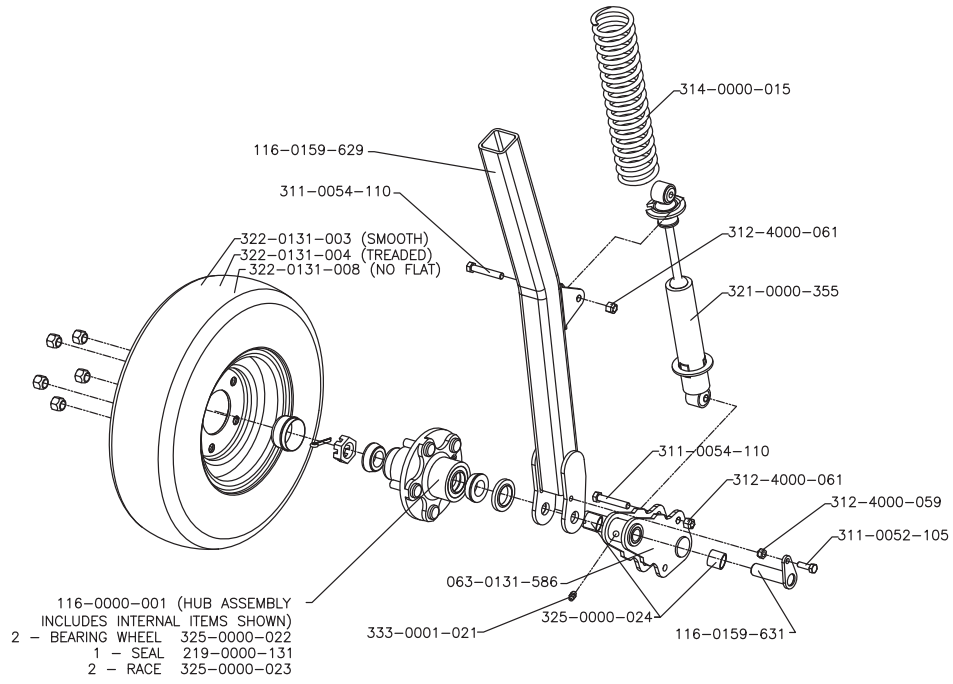

Sensors

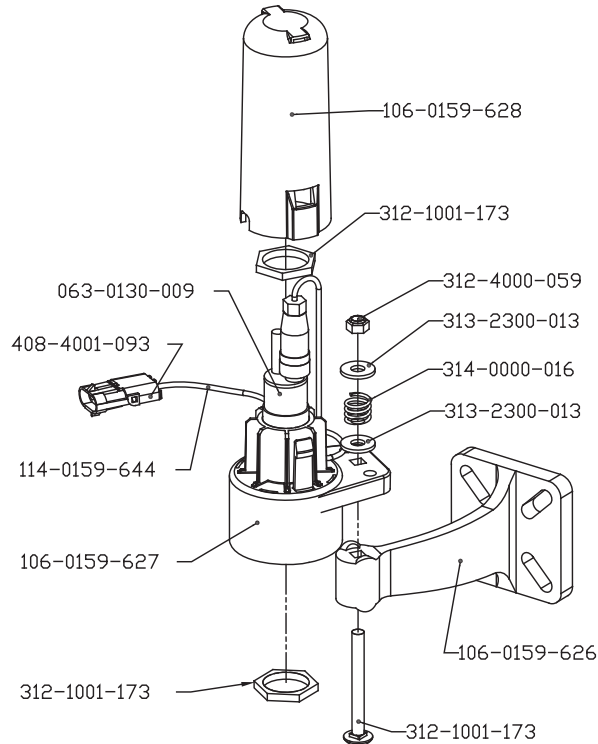

E

Electrical

Safety 2

H

Hydraulic

Fittings 4

Safety 2

I

Important Safety Information

Electrical 2

Hydraulics 2

K

Kit Contents

PowerGlide Plus 5

UltraGlide 21

P

Point of Reference 4**PowerGlide Plus**

Install

Gauge Wheels 16

Gauge Wheel Mounting Locations 16

Mounting the Gauge Wheels 16

Hydraulic System 8

Hydraulic Schematic 15

Installing Fittings on AutoBoom Valve 11

Left and Right Cylinder Hoses 14

Mount the AutoBoom Valve 12

Pressure and Tank Hoses 13

Removing the Orifice Fittings 9

Wiring 17

AutoBoom Valve Connections 19

Installing the AutoBoom Node 17

Power/CAN Connectors 18

Tilt and Center Rack Controls 19

Wiring Connections 17

Kit Contents 5

Preparing for Installation 4

R

Recommendations 4**Replacement Parts**

Sensors 38

Valve Blocks 37

Wheels 38

T

Tools Needed 4

U

UltraGlide

Install

Gauge Wheels 32

Gauge Wheel Mounting Locations 32

Mounting the Gauge Wheels 32

Hydraulic System 25

Hydraulic Schematic 29

Installing Fittings on AutoBoom Valve 25

Left and Right Cylinder Hoses 28

Mounting AutoBoom Valve 26

Pressure and Tank Hoses 27

Sensors 30

Boom Sensor Mounting Locations 30

Connect the Sensor Cables 31

Mount the Boom Sensors 30

Mount the Center Rack Sensor 31

Wiring 33

AutoBoom Valve Connections 35

Connecting the Harness Cable to the Sensors 35

Installing the AutoBoom Node 33

Power/CAN Connectors 34

Tilt and Center Rack Controls 35

Wiring Connections 33

Kit Contents 21

RAVEN

RAVEN INDUSTRIES

Limited Warranty

What Does this Warranty Cover?

This warranty covers all defects in workmanship or materials in your Raven Applied Technology Product under normal use, maintenance, and service.

How Long is the Coverage Period?

Raven Applied Technology Products are covered by this warranty for 12 months after the date of purchase. This warranty coverage applies only to the original owner and is nontransferable.

How Can I Get Service?

Bring the defective part and proof of purchase to your Raven Dealer. If your Dealer agrees with the warranty claim, the Dealer will send the part and proof of purchase to their distributor or to Raven Industries for final approval.

What Will Raven Industries Do?

Upon confirmation of the warranty claim, Raven Industries will, at our discretion, repair or replace the defective part and pay for return freight.

What is not Covered by this Warranty?

Raven Industries will not assume any expense or liability for repairs made outside our facilities without written consent. Raven Industries is not responsible for damage to any associated equipment or products and will not be liable for loss of profit or other special damages. The obligation of this warranty is in lieu of all other warranties, expressed or implied, and no person or organization is authorized to assume any liability for Raven Industries.

Damages caused by normal wear and tear, misuse, abuse, neglect, accident, or improper installation and maintenance are not covered by this warranty.

R A V E N

Miller Condor G-Series Mono Boom
AutoBoom™ Installation Manual
(P/N 016-0230-094 Rev B 12/09)

Simply improving your position.™



Raven Industries
Applied Technology Division
P.O. Box 5107
Sioux Falls, SD 57117-5107

Toll Free (U.S. and Canada): (800)-243-5435
or Outside the U.S. :1 605-575-0722
Fax: 605-331-0426
www.ravenprecision.com
atdinfo@ravenind.com

Notice: This document and the information provided are the property of Raven Industries, Inc. and may only be used as authorized by Raven Industries, Inc. All rights reserved under copyright laws.