

RAVEN

Simply improving your position.SM

SmarTrax™ Installation Manual

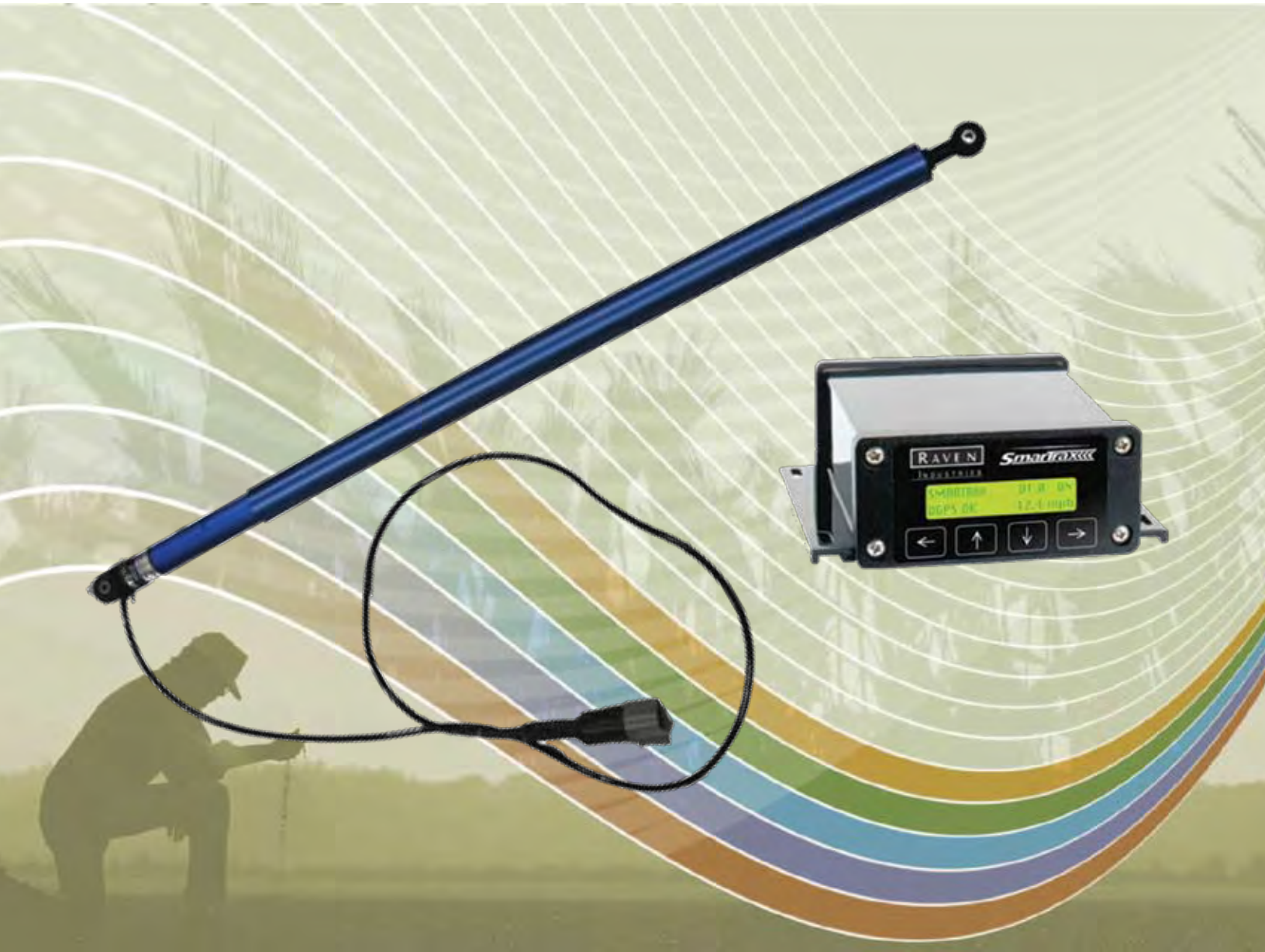

Open Center Load Reactive Hydraulic Systems

Disclaimer

While every effort has been made to ensure the accuracy of this document, Raven Industries assumes no responsibility for omissions and errors. Nor is any liability assumed for damages resulting from the use of information contained herein.

Raven Industries shall not be held responsible or liable for the effects of atmospheric conditions and sunspot activity on the performance of our products.

Raven Industries cannot guarantee the accuracy, integrity, continuity, or availability of the GPS signal from the U.S. Department of Defense/NAVSTAR GPS satellites, the OmniSTAR correction service or the WAAS correction service.

Raven Industries accepts no responsibility for the use of the signal for other than the stated purpose. Raven Industries shall not be responsible or liable for incidental or consequential damages or a loss of anticipated benefits or profits, work stoppage or loss or impairment of data arising out of the use, or inability to use, the SmarTrax or any of its components.

CHAPTER

1

INTRODUCTION

About this Guide

The aim of this guide is to provide up to date reference information about installation of SmarTrax.

Who is it for

This guide is intended for use by distributors who install new SmarTrax systems for Raven Industries.

What it covers

This guide presents:

- a parts checklist for steering installation
- installation procedures for SmarTrax hydraulic kit and cable routing

Updates

This guide will be updated periodically to reflect changes and additions to the range of SmarTrax products and to ensure that this guide fulfills user's needs for reference information. Updates will be supplied as soon as they are available.

Notes:

CHAPTER

2

SAFETY REQUIREMENTS

This section is divided between general safety precautions, specific safety measures for hydraulic and electrical system, and safety symbols used in this document.

The machine must remain stationary and switched off, and Steering Assist™ disengaged while installation or maintenance is being carried out.

Safety Precautions

•When working with or near a machine with SmarTrax installed, the following safety measures must be observed. The operator *must*:

- Be alert and aware of surroundings.
- Avoid operating the SmarTrax while under the influence of alcohol or an illegal substance.
- Remain in the operator's position at all times when SmarTrax is engaged.
- Be in complete control of machine at all times when SmarTrax is engaged.
- Remain within boundaries of a defined field when SmarTrax is engaged.
- Avoid driving the machine with SmarTrax engaged on any public thoroughfare or main road.
- Determine and remain a safe working distance from other machinery, equipment, and obstacles. The operator is responsible for disengaging SmarTrax when safe working distance has diminished.

- Determine and remain a safe working distance from other farm personnel or bystanders. The operator is responsible for disengaging SmarTrax when safe working distance has diminished.
- Ensure SmarTrax is disengaged prior to starting any maintenance work on SmarTrax or machine.

Hydraulic Safety Precautions

When disconnecting hydraulic hoses or when purging is required, be aware that hydraulic oil may be hot and under high pressure. Caution must be exercised.

Any work carried out on the hydraulics system must be performed in accordance with machine manufacturer's approved maintenance instructions.

Raven Industries recommends that appropriate protective equipment be worn.

It is imperative that, during installation, diagnostics, maintenance, or routine machine servicing, **all precautions are taken to prevent foreign material or contaminants from being introduced into the hydraulic system.**

Objects or materials that are able to bypass the machine's hydraulic filtration system will adversely reduce performance, and possible damage hydraulic valves.

Electrical Safety Precautions

Do not reverse power leads. Doing so will cause severe damage to equipment. Always check to make sure that power leads are connected to the correct polarity as marked.

Ensure that power cable is the last cable to be connected.

Safety Symbols



WARNING: Identifies information about practices or circumstances that can lead to personal injury or death, property damage or economic loss.

Warning statements help you:

- Identify a hazard
- Avoid a hazard
- Recognize consequences

NOTE: Identifies information that is critical for successful application and understanding of the product.

Safety Warning Labels

Safety Warning Labels have been provided to highlight to users the importance of:

- Avoiding damage to Steering Position Sensor
- Not tampering with SmarTrax hydraulic valves

These warning labels are to be placed in the specified locations as indicated below.

Steering Position Sensor Warning Label

It is essential to avoid damage to Steering Position Sensor (SPS). Raven Industries has provided a **‘Do Not Step’** warning label. Place label on top surface of Steering Position Sensor (*as shown below*) facing up and visible to operator.



Steering Position Sensor Warning label



Hydraulic Warning Label

This label should be placed on the steering assist manifold or on the Hydraulic Valve Mounting Bracket as shown below. **‘Tampering with hydraulic valves may cause serious injuries or death & will void warranty’**.

NOTE: The picture below is only an example of where to place the hydraulic warning label on the steering assist manifold. Placement will vary depending on the valve used.

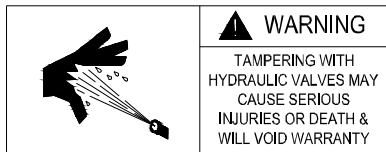

Hydraulic Warning label

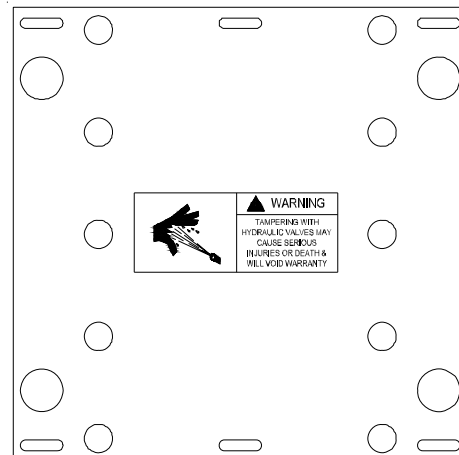

Driving Safety Requirements

This section outlines the safety requirements used when driving a vehicle using the SmarTrax system.

Areas of Operation

SmarTrax must only be used on private property without public access and within cleared fields. It must NOT be used on any public roads or access ways. Raven Industries advise that users familiarize themselves with SmarTrax operations by first reading the Machine Operator Guide.

Avoidance of People

The SmarTrax must not be operated in the vicinity of bystanders. Bystanders must be well away from the machine's path while it is operating with SmarTrax engaged.

Avoidance of Machinery and Equipment

The SmarTrax operator must allow a safe distance between the machine's path and other machinery or equipment. To determine a safe distance, consider possible incorrect operation, loss of GPS and the distance required for the machine to stop.

Avoidance of Obstacles

SmarTrax **CANNOT** detect obstacles such as fences, trees or boulders that are located within a defined field. SmarTrax assists the machine operator to steer the machine in straight lines in cleared fields. The machine operator must be conscious of and avoid obstacles.

Responsibilities of Operator

The machine operator must remain in complete control of the machine at all times. Hands free operation occurs only when SmarTrax is enabled.

The machine operator remains fully responsible for machine operation and must remain in the operator's position at all times while SmarTrax is engaged.

Disengaging SmarTrax

The operator must disengage SmarTrax if an obstacle is in the line of travel. The operator must disengage SmarTrax by using one of the following methods listed below:

- Turn steering wheel in the normal manner
- Stop machine
- Press remote activation switch

Operational Emergency Safety Steps

In case of an emergency, take one of the following steps to disengage SmarTrax:

- Press brake and decelerate to under 1.6 mph / 1 kph;
- Turn steering wheel in the normal manner; or
- Press remote activation switch

Contacting Raven Industries

We welcome your feedback about this manual. If you have any comments or suggestions for improvement, please let us know by contacting our Customer Support Center by any of the following methods:

- ◆ **Via phone:** 1-800-243-5435
- ◆ **Via mail:**
Raven Industries
Flow Control Division
205 E. 6th St.
Sioux Falls, SD 57104
- ◆ **Via email:** fcinfo@ravenind.com

Notes:

CHAPTER

3

INSTALLING HYDRAULIC COMPONENTS

Installing Hydraulic Bracket

1. The bracket is intended to be universal to accommodate valve mounting on multiple machines. However, some modification may be necessary to fit the desired application.
2. The valve mounting bracket is made of two parts. The bracket with the valve mounting holes may be used independently and the secondary mounting plate may be discarded if not needed.

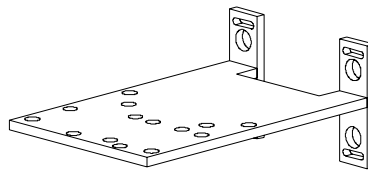

VALVE MOUNTING BRACKET

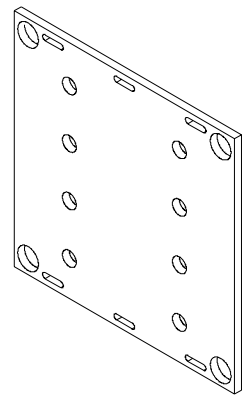

BRACKET MOUNTING PLATE

3. Mount the bracket as close as possible to the steering orbital, in order to keep hydraulic hoses as short as possible. Also, mount the bracket in a position that will protect the valve from getting damaged from mud, crops, etc.
4. Mount the bracket mounting plate by using the existing holes in the vehicle frame. The bracket mounting plate may need to have additional holes drilled in order to accommodate various hole patterns.

5. If both brackets are used in the installation, first attach the bracket mounting plate to the vehicle. Once the place is installed, attach the valve mounting plate using the supplied bolts and washers.
6. The bracket mounting plate is designed to provide valve height adjustment for easier hose routing by using five pairs of mounting holes. To adjust bracket up or down, unbolt valve mounting bracket and move to the desired height and reattach using the supplied bolts.

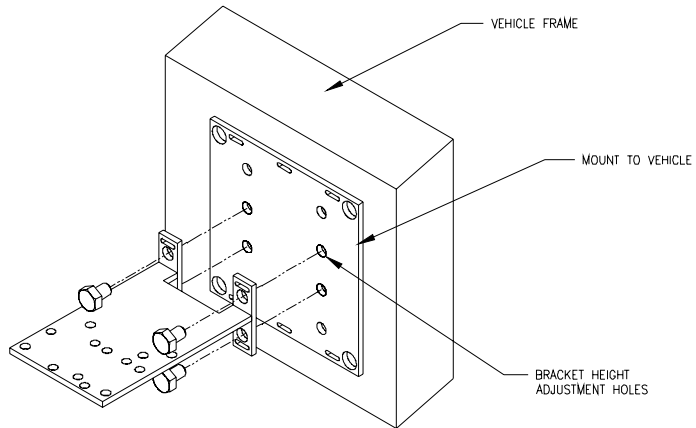

7. In some installations, it may be more appropriate to use only the valve mounting bracket. If so, mount the bracket using the existing holes in the frame to securely fasten the bracket to the frame.

CHAPTER

4

HYDRAULIC SYSTEM INSTALLATION

**Safety
Precautions
for
Connecting
Hydraulic
Hoses****WARNINGS:**

- The machine must remain switched off, isolated, and stationary, while installation and maintenance is being done.
- When disconnecting hydraulic hoses, or when purging is required, be aware that hydraulic oil may be under pressure and hot. **Caution** must be exercised.
- The risk of contamination of the hydraulic system is at its greatest when any fitting is removed. It is **essential** that, prior to the loosening of any fitting, the fitting is cleaned thoroughly with a spray cleaner such as Brake Clean™.
- **Note:** Brake Clean™ can cause premature failure to o-rings such as those used in ORFS fittings. If a fitting is to be cleaned internally, the o-ring should be removed first and cleaned with fiberless cloth.
- Lines should be capped immediately on removal, to minimize contamination.

To install the hydraulic steering kit as efficiently as possible, follow the order outlined. Failure to do so can result in damage to components such as hydraulic hoses due to incorrect hose routing.

Prior to starting installation, ensure that the machine is switched off, pressure is relieved from the hydraulic system, and the tractor has cooled to room temperature. This can be done by turning the steering wheel left and right.

WARNING: Prior to working with the hydraulic system, user must undertake the following safety provisions:

- **Wear appropriate protective equipment at all times,**
- **Perform all work in accordance with the tractor manufacturer's instructions, and**
- **Be aware that hydraulic oil may be hot and under high pressure when disconnecting hydraulic hoses or when purging is required - exercise extreme caution.**

Connecting Hydraulic Hoses

To install each component of the hydraulic kit as efficiently as possible, follow the order in which this procedure is outlined. Failure to do so can result in damage to hydraulic hoses due to incorrect hose routing.

When installing the hydraulic hoses, refer to the following schematic for the correct hose connections and routings.

Before Smartrax Installation

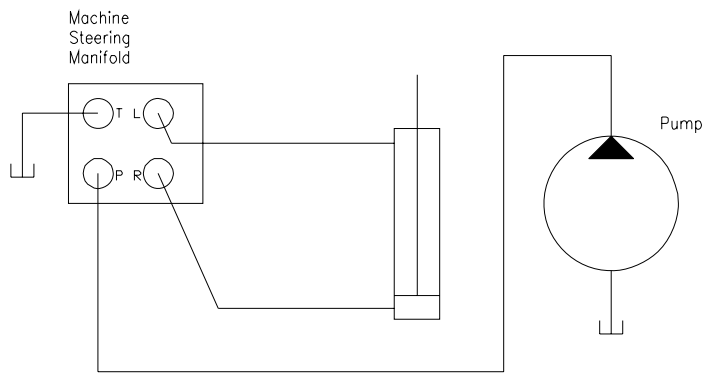

After Smartrax Installation

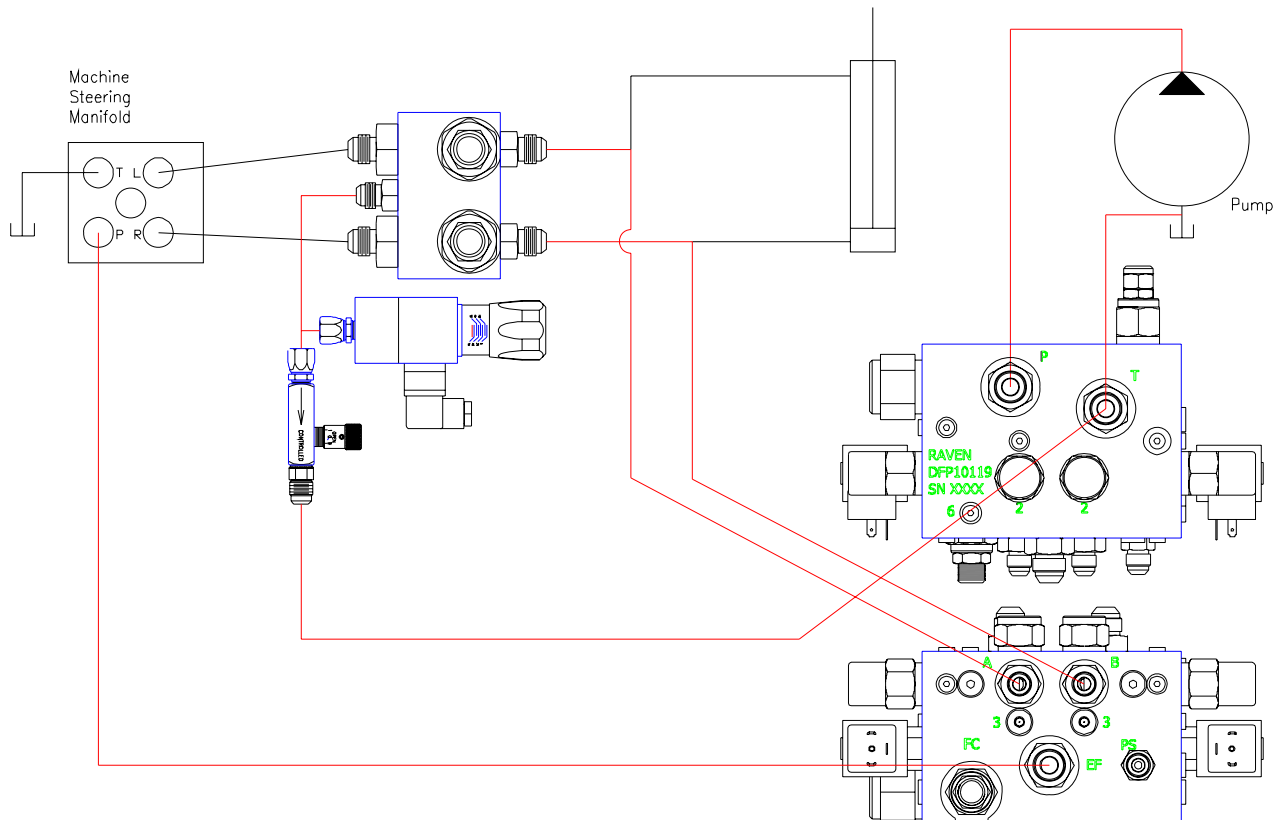

Installing Hydraulic Components

The Raven Universal Steering Kit does **NOT** come supplied with hoses. It is important that if new hoses are made, make every effort to properly clean them to prevent any contamination to the vehicles hydraulic system.

Raven Steering Control Valve Configuration

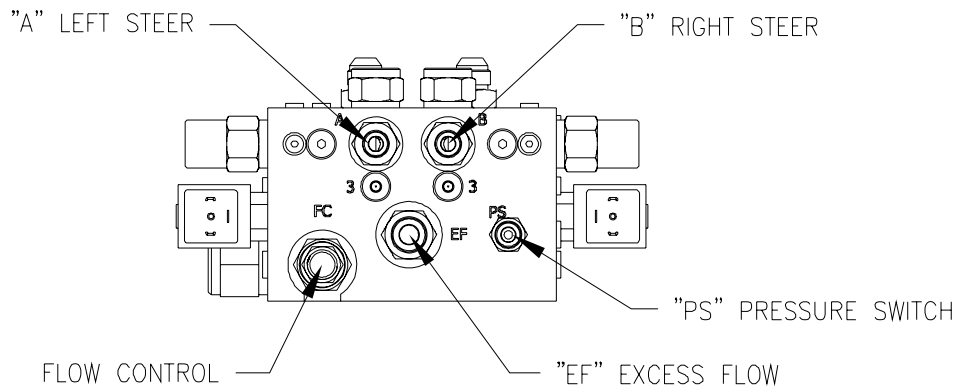
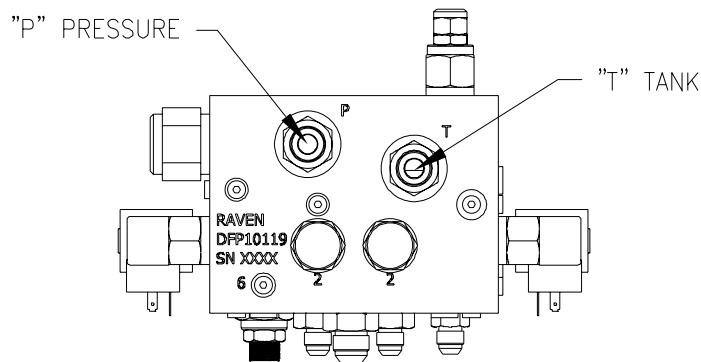
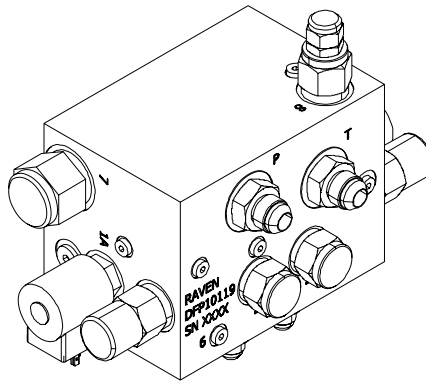

- A Port** - Controls left steer
- B-Port** - Controls right steer
- P-Port** - Pressure input port into valve
- T-Port** - Excess Flow port, returning fluid back to the tank
- EF-Port** - Excess Flow, Power Beyond Feature
- PS-Port** - Pressure Switch Port, must be plugged off

Installing The Steering Control Valve Hoses

Pressure Hose

1. Identify the pressure port on the vehicles steering orbital. Hose may need to be traced to the hydraulic pump for proper identification. Once the port has been identified, remove the hose from the vehicles steering orbital and install it directly to the P-Port on the Raven steering control valve.
2. An additional 45° or 90° elbow may be installed on the Raven valve to help hose routing. These elbows will be found in the hydraulic fitting kit

Excess Flow Hose

1. Construct a new hose to run from the EF-Port on the Raven steering control valve to the pressure port on the vehicles steering orbital.
3. An additional 45° or 90° elbow may be installed on the Raven valve to help hose routing. These elbows will be found in the hydraulic fitting kit..

Left Steer Hose

1. Identify the left steer port on the vehicles steering orbital. Hoses may need to be traced from the hydraulic cylinder to the machine's orbital for proper identification. Once the left steer port has been identified, remove the hose from the steering orbital. Install an appropriate tee fitting, found in the Raven adapter kit, to the steering orbital. Once the tee fitting is installed, reattach the original hose. (NOTE: The tee may be installed at the steering cylinder for easier installation.)
2. Construct a new hose to run from the A-Port on the Raven steering control valve to the open branch on the installed tee fitting.
3. An additional 45° or 90° elbow may be installed on the Raven valve to help hose routing. These elbows will be found in the hydraulic fitting kit.

Right Steer Hose

1. Identify the right steer port on the vehicles steering orbital. Hoses may need to be traced from the hydraulic steering cylinder to the machine's orbital for proper identification. Once the right steer port has been identified, remove the hose from the steering orbital. Install an appropriate tee fitting, found in the Raven adapter kit, to the steering orbital. Once the tee fitting is installed, reattach the original hose. (NOTE: The tee may be installed at the steering cylinder for easier installation.)
2. Construct a new hose to run from the B-Port on the Raven steering control valve to the open branch on the installed tee fitting.
3. Add additional 45° or 90° elbow may be installed on the Raven valve to help hose routing. These elbows will be found in the hydraulic fitting kit

Tank Hose

1. Identify the tank port on the vehicles steering orbital. Hose may need to be traced to the hydraulic reservoir for proper identification. Once the tank port has been identified, remove the hose from the steering orbital and install an appropriate fitting, found in the Raven adapter kit. Once the tee fitting is installed, reattach the original hose to the tee.
2. Identify the T-port on the Raven steering control valve. On the T-port of the Raven valve, install a 6-6-6 JIC Tee fitting. Once the tee is installed, attach a new hose to one branch of the tee and route the hose and attach it to the tee fitting on the "T" port of the steering orbital.

3. On the remaining open end of the tee fitting on the Raven steering control valve, attach the flow control valve. (**Note: Be sure that the arrow on the side of the flow control valve points in toward the tee, and toward direction of flow to the tank.**)

Pressure Switch Hose

1. Identify the PS port on the Raven steering control valve. Remove the previously installed fitting in the valve and install the properly sized port plug supplied in the Raven adaptor kit.
2. Identify the Brake port on the counter balance valve. Attach the pressure switch to the fitting in the Brake port using the swivel end of the tee on the Pressure Switch.
3. Create a new hose to run from the open end of the tee on the pressure switch to the open end of the flow control valve. (**Note: Be sure that the arrow on the side of the flow control valve is pointing away from the pressure switch, so that it is pointing towards flow to the tank.**)

Hydraulic System Checks and Setup

1. Once all hoses are installed, go back and verify that all connections are tight, and that hoses are attached to their appropriate ports.
2. Once hydraulic system has been plumbed, start tractor and verify there are no leaks and hoses have been hooked up correctly.



WARNING! Upon initial system start up, bystanders must stand clear, in case a fitting has not been completely tightened.

3. Once machine is started and running, inspect hoses, fittings and valves to verify system is leak free.
4. Purge air from the system by slowly turning steering wheel from lock to lock several times.
5. Once valve is tested, attach supplied warning label on or near the valve.

Setting Override Pressure Switch

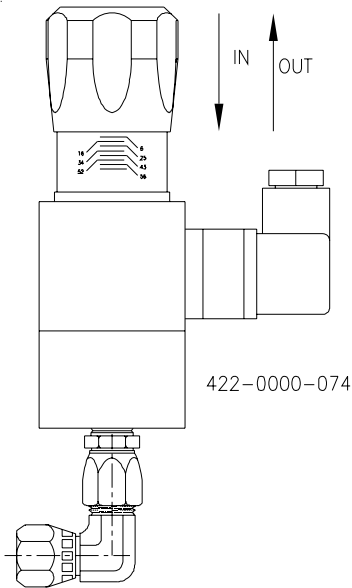

1. The Override Pressure Switch must be set in order for SmarTrax to disengage when operator moves steering wheel.
2. The pressure switch can not be set until the SmarTrax Controller is installed and all wiring is complete.
3. To set the pressure switch, go to the Solenoid Configuration Menu on the SmarTrax Controller. Once at this menu, arrow down to "<Les R>" screen.
4. With tractor running and no movement of steering wheel, the "s" should display as lower case. If "S" is upper case, pressure switch knob must be turned in until a lower case "s" is displayed.
5. Once the display reads lower case "s" with the vehicle running and stationary, begin to turn the steering wheel. When wheel is turned, the "s" should change to an upper case "S" indicating that the system is deactivated. If this does not happen, the pressure switch knob must be turned out until the "s" changes to upper case when the wheel is turned and back to lower case when the wheel is stopped.

Setting the Flow Control Valve

1. The Flow Control Valve is used to dampen any hydraulic system spikes which may cause the pressure switch to inadvertently disengage SmarTrax, caused from using Auxiliary hydraulic functions.
2. Begin with the flow control valve completely closed, and set the pressure switch as stated in the previous section.
3. Once the pressure switch has been set, run SmarTrax and, at the same time, run any auxiliary hydraulic function such as boom control.
Note: When running auxiliary hydraulics, bottom out the auxiliary hydraulic cylinder to get max pressure spikes in the hydraulic system.
4. If the SmarTrax disengages, open the flow control one turn and repeat the setup procedure. Do this process until the hydraulic spikes don't effect the pressure switch.

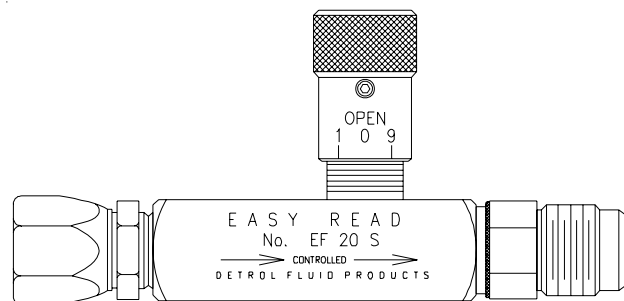

334-0002-053

Setting the Wheel Turning Rate

1. The steering control valve will not come from the factor preset. Flow rates to the cylinders must be set so the wheels turn left and right at the same rate.
2. The lock to lock timing of the wheels should be approximately 6-8 seconds.
3. To pulse the steering control valve, the steering wheel should be turned all the way to the left, and then pulsed to the right, using the SmarTrax controller.
4. To pulse the steering control valve using the SmarTrax controller, scroll to the Solenoid Control Configuration menu. The “manual steering” screen will be displayed first. By pressing the right arrow, the wheels will pulse to the right. Pressing the left arrow will pulse the wheels to the left.
5. Once the system is ready to pulse the steering control valve, it is very important that an accurate time measurement is taken from lock to lock on the wheels.
6. If the time constant is not within the specifications stated above, the flow control valve must be set.
7. To adjust, first loosen the jam nut on the flow control valve. Once the jam nut is loose, turn the adjustment point on the flow control valve in to slow the wheels and out to speed the wheels up. (For accurate measurement, turn at 1/4 turn increments.)
8. When the wheel pulse speeds are set, the jam nut can be locked down.
9. Once the valve has been adjusted, return the wheels to the center and turn off the vehicle.

Hydraulic System Warning!

Install the hydraulic system warning label provided to the hydraulic bracket.

- Before placing onto the bracket, make sure the surface is clean.

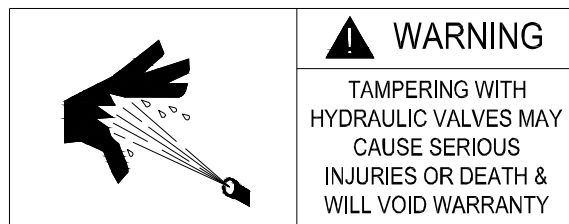

CHAPTER

5

CABLE CONNECTION AND ROUTING

Wiring the Solenoid and Override Switch

Note: The Cable Connection and Routing section of this manual is generic and has been designed to cover all tractor types currently available.

Before starting the Cable Connection and Routing section of this document you should first ensure that all components of the hydraulic steering kit are installed securely and neatly.

1. In this portion, the hydraulic valve and the flow monitor will be wired using the cable labeled Solenoid, Override, Float Valve, and S.P.S.
2. The following schematic will show the wiring of the hydraulic system.
3. Once the wiring is connected, ensure the Solenoid cable is cable-tied neatly and securely away from moving parts.

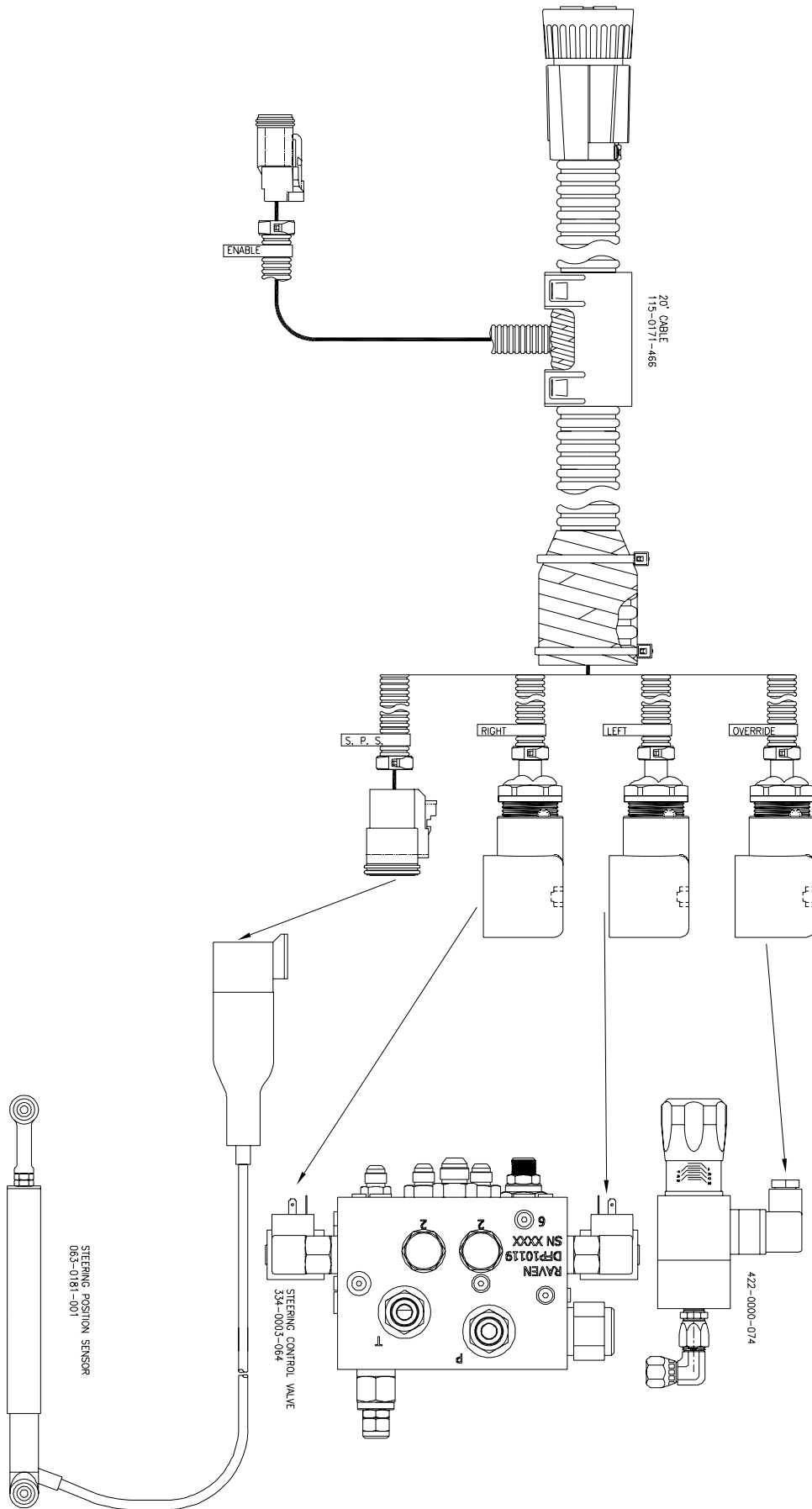

RAVEN

RAVEN INDUSTRIES

Limited Warranty

What Does this Warranty Cover?

This warranty covers all defects in workmanship or materials in your Raven Applied Technology Product under normal use, maintenance, and service.

How Long is the Coverage Period?

Raven Applied Technology Products are covered by this warranty for 12 months after the date of purchase. This warranty coverage applies only to the original owner and is nontransferable.

How Can I Get Service?

Bring the defective part and proof of purchase to your Raven Dealer. If your Dealer agrees with the warranty claim, the Dealer will send the part and proof of purchase to their distributor or to Raven Industries for final approval.

What Will Raven Industries Do?

Upon confirmation of the warranty claim, Raven Industries will, at our discretion, repair or replace the defective part and pay for return freight.

What is not Covered by this Warranty?

Raven Industries will not assume any expense or liability for repairs made outside our facilities without written consent. Raven Industries is not responsible for damage to any associated equipment or products and will not be liable for loss of profit or other special damages. The obligation of this warranty is in lieu of all other warranties, expressed or implied, and no person or organization is authorized to assume any liability for Raven Industries.

Damages caused by normal wear and tear, misuse, abuse, neglect, accident, or improper installation and maintenance are not covered by this warranty.

The logo for Raven Industries, featuring the word "RAVEN" in white, uppercase letters on a dark blue rectangular background.

Open Center Load Reactive Hydraulic Systems
SmarTrax™ Installation Manual
(P/N 016-9001-012 Rev C 2/09)

Simply improving your position.™



Raven Industries
Applied Technology Division
P.O. Box 5107
Sioux Falls, SD 57117-5107

Toll Free (U.S. and Canada): (800)-243-5435
or Outside the U.S. :1 605-575-0722
Fax: 605-331-0426
www.ravenprecision.com
atdinfo@ravenind.com

Notice: This document and the information provided are the property of Raven Industries, Inc. and may only be used as authorized by Raven Industries, Inc. All rights reserved under copyright laws.