

# RS1™ Installation Manual for Claas OSI Harvesters

016-5036-077 Rev. A

9/2022

E41935



## DISCLAIMER

While every effort has been made to ensure the accuracy of this document, Raven Industries assumes no responsibility for omissions and errors. Nor is any liability assumed for damages resulting from the use of information contained herein.

Raven Industries shall not be responsible or liable for incidental or consequential damages or a loss of anticipated benefits or profits, work stoppage or loss, or impairment of data arising out of the use, or inability to use, this system or any of its components. Raven Industries shall not be held responsible for any modifications or repairs made outside our facilities, nor damages resulting from inadequate maintenance of this system.

As with all wireless and satellite signals, several factors may affect the availability and accuracy of wireless and satellite navigation and correction services (e.g. GPS, GNSS, SBAS, etc.). Therefore, Raven Industries cannot guarantee the accuracy, integrity, continuity, or availability of these services and cannot guarantee the ability to use Raven systems, or products used as components of systems, which rely upon the reception of these signals or availability of these services. Raven Industries accepts no responsibility for the use of any of these signals or services for other than the stated purpose.



<b>Chapter 1</b>	<b>Important Information.....</b>	<b>1</b>
Safety .....		1
Displays and Control Consoles .....		1
Electrical safety .....		2
Touch Screen .....		2
Recommendations and Best Practices .....		2
Harness Routing .....		2
<b>Chapter 2</b>	<b>Introduction.....</b>	<b>5</b>
Installation Best Practices .....		6
Recommendations .....		6
Point of Reference .....		6
Kit Components .....		7
Updates .....		9
<b>Chapter 3</b>	<b>Installation .....</b>	<b>11</b>
Locate OSI Connector .....		11
Preparation .....		13
Prepare the Cab .....		13
Mount the Display Bracket .....		17
Route And Connect The In cab Cabling .....		19
System Drawings .....		21
<b>Chapter 4</b>	<b>Peripheral Component Installation.....</b>	<b>23</b>
Install the Field Computer .....		23
Mount And Connect The Field Computer .....		23
Prepare External Routing .....		25
Mount the RS1™ .....		27
Roof Access and Prep for Mounting Hardware .....		27
Secure the RS1™ Mounting Bracket .....		29
Route And Connect The Out Of Cab Cabling .....		32
<b>Chapter 5</b>	<b>Activate Automatic Steering.....</b>	<b>35</b>
Activate Automatic Steering .....		35



## SAFETY

### **NOTICE**

Follow the operation and safety instructions included with the implement and/or controller and read this manual carefully before installing or operating this Raven system.

- Follow all safety information presented within this manual. Review implement operation with your local dealer.
- Contact a local Raven dealer for assistance with any portion of the installation, service, or operation of Raven equipment.
- Follow all safety labels affixed to system components. Be sure to keep safety labels in good condition and replace any missing or damaged labels. Contact a local Raven dealer to obtain replacements for safety labels.

Observe the following safety measures when operating the implement after installing this Raven system:

- Do not operate this Raven system or any agricultural equipment while under the influence of alcohol or an illegal substance.
- Be alert and aware of surroundings and remain in the operator seat at all times when operating this Raven system.
  - Do not operate the implement on any public road with this Raven system enabled.
  - Disable this Raven system before exiting the operator seat.
  - Determine and remain a safe working distance from obstacles and bystanders. The operator is responsible for disabling the system when a safe working distance has diminished.
  - Disable this Raven system prior to starting any maintenance work on the implement or components of this Raven system.
- Do not attempt to modify or lengthen any of the system control cables. Extension cables are available from a local Raven dealer.

## DISPLAYS AND CONTROL CONSOLES

- If the display will not be used for an extended period, it is best to remove the display from the machine and store it in a climate controlled environment. This may help to extend the service life of electronic components.
- To prevent theft, secure the display and GNSS antenna when leaving the machine unattended.

## CAUTION

### ELECTRICAL SAFETY

- Always verify that power leads are connected to the correct polarity as marked. Reversing the power leads could cause severe damage to the Raven system or other components.
- To prevent personal injury or fire, replace defective or blown fuses with only fuses of the same type and amperage.
- Do not connect the power leads to the battery until all system components are mounted and all electrical connections are completed.
- Always start the machine before initializing this Raven system to prevent power surges or peak voltage.
- To avoid tripping and entanglement hazards, route cables and harnesses away from walkways, steps, grab bars, and other areas used by the operator or service personnel when operating or servicing the equipment.

### TOUCH SCREEN

- Only touch the touch-screen with your finger or by using a special touch-screen stylus/pen. Operating the touch-screen with sharp objects may cause permanent damage to the screen.
- Only clean the screen using a damp cloth. Never use caustic or other aggressive substances.

---

## RECOMMENDATIONS AND BEST PRACTICES

### HARNESS ROUTING

The word “harness” is used to describe any electrical cables and leads, both bundled and unbundled. Use the following guidelines and recommendations when connecting and routing harnesses while installing or maintaining this Raven system:

- Leave protective caps/covers over harness connectors until needed to avoid dirt and moisture from contaminating electrical circuits.
- Secure the harness to the frame or solid structural members at least every 30 cm (12 in.).
- Follow existing harness runs already routed on the implement as much as possible. Proper harness routing should:
  - Secure harnessing and prevent the harness from hanging below the implement.
  - Provide sufficient clearance from moving components and operational zones around shafts; universal joints and suspension components; pulleys, gears, belts, and chains; moving linkages, cylinders, articulation joints, etc.
  - Protect harnessing from field debris and surrounding hazards (e.g. tree limbs, fence posts, crop stubble, dirt clumps or rocks that may fall or be thrown by the implement).
  - Protect harnessing from sharp bends, twisting, or flexing over short distances and normal implement operation.
  - Connectors and splices should not be located at bending points or in harness sections that move.
  - Ensure sufficient length for free movement of the implement during normal operation and prevent pulling, pinching, catching, or rubbing, especially in articulation and pivot points. Clamp harnessing securely to force controlled movement of the harness.

- Avoid abrasive surfaces and sharp edges such as sheared or flame cut corners, fastener threads or cap screw heads, hose clamp ends, etc.
- Do not connect, affix, or allow harnessing to come into contact with components with high vibration forces, hot surfaces, or components carrying hot fluids beyond the temperature rating of harness components.
  - Harnessing should be protected or shielded if routing requires the hose to be exposed to conditions beyond harnessing component specifications.
- Avoid routing harnesses in areas where damage may occur due to build up of material (e.g. dirt, mud, snow, ice, etc.).
- Avoid routing harnesses in areas where the operator or service personnel might step or use as a grab bar.

**IMPORTANT:** Avoid applying direct spray or pressure washing of electrical components and connections. High pressure streams and sprays can penetrate seals, cause corrosion, or otherwise damage electrical components.  
When performing maintenance:

- Inspect electrical components and connectors for corrosion, damaged pins or housings, etc. Repair or replace components or harnessing as necessary.
- Ensure connectors are kept clean and dry. Apply dielectric grease to the sealing surfaces of all connections exposed to moisture, dirt, debris, and other contaminants. Repair or replace harnessing as necessary.
- Clean electrical components with pressurized air, aerosol electrical cleaning agent, or low pressure rinse.
- Remove visible surface water from electrical components and connections using pressurized air or an aerosol cleaning agent. Allow components to dry thoroughly before reconnecting cables.





---

This manual applies to the following machines.

**Make.** Claas

**Model.** OSI Harvesters including Lexion, Trion, Tucano, Avero, and Jaguar

**FIGURE 1. Claas Lexion 8700 Harvester**



## INSTALLATION BEST PRACTICES

	<p><b>WARNING</b></p> <p>Carefully read and follow all safety requirements and precautions contained in this manual and the machine-specific Installation Manual. Failure to follow safety instructions may lead to equipment damage, personal injury, or death.</p>
---	--

### RECOMMENDATIONS

Before installing the RS1™ system, park the machine where the ground is level, clean, and dry. Bleed pressure from the hydraulic system and leave the machine turned off for the duration of the installation process.

During the installation process, follow good safety practices. Be sure to carefully read the instructions in this manual as you complete the installation process.

Raven Industries recommends the following best practices when installing or operating the RS1™ system for the first time, at the start of the season, or when moving the RS1™ system to another machine:

- Verify that the machine hydraulic system is using fresh oil and that the filters have been recently changed.
- Ensure there are no issues with the machine hydraulic system (e.g., pump issues, faulty hydraulic motors, fine metal deposits in the hydraulic hoses, etc.).

### POINT OF REFERENCE

The instructions in this manual assume that you are standing behind the machine, looking toward the cab.

## KIT COMPONENTS

This section contains a list of the components that are included in the RS1™ kit. Before beginning the system installation, compare the items in the kit with the components on this list. If you have questions about the kit, contact your Raven dealer.

FIGURE 2. RS1™ with CR7™ Kit for Class OSI Harvesters (P/N 117-5036-077 Rev. A)

QTY	PART #	DESCRIPTION
1	053-0159-323	BOX, SHIPPING
1	115-4010-253	CABLE, RS1, CLAAS OSI HARVESTERS
1	117-5001-058	KIT, ROOF, RS1, STICK-ON
1	115-7300-092	CABLE, CR7, ISO VT ONLY
1	107-0172-765	BRACKET, RAM MOUNT, CLAAS LEXION
1	117-8000-557	KIT, MOUNTING, CLAAS OSI HARVESTERS
1	107-0172-767	PANEL, DISPLAY CONN, CLAAS LEXION
1	016-0171-649	SHEET, WARRANTY/HELP

FIGURE 3. RS1™ with Viper4™ Kit for Class OSI Harvesters (P/N 117-5036-078 Rev. A)

QTY	PART #	DESCRIPTION
1	053-0159-323	BOX, SHIPPING
1	115-4010-253	CABLE, RS1, CLAAS OSI HARVESTERS
1	117-5001-058	KIT, ROOF, RS1, STICK-ON
1	115-7300-135	CABLE, CONSOLE, VIPER 4 ISO VT
1	107-0172-765	BRACKET, RAM MOUNT, CLAAS LEXION
1	117-8000-557	KIT, MOUNTING, CLAAS OSI HARVESTERS
1	107-0172-767	PANEL, DISPLAY CONN, CLAAS LEXION
1	016-0171-649	SHEET, WARRANTY/HELP

FIGURE 4. RS1™ Stick On Roof Kit for Class OSI Harvesters (P/N 117-5001-058 Rev. A)

QTY	PART #	DESCRIPTION
1	116-0159-802	BRACKET, LATCH PLATE B, RS1
1	107-0172-531	BRACKET, FIXED MOUNT, RS1
2	063-0174-067	BRACKET ASSEMBLY, RS1 MOUNT, STICK-ON, W/ TAPE
4	311-0003-041	SCKT SCREW CS 82D #1/4-20X1/2"
4	312-6001-022	HEX LOCK NUT DIN985 - 8 - M8
4	313-6000-013	WASHER, ZN, DIN125A M8

FIGURE 5. RS1™ Mounting Kit for Class OSI Harvesters (P/N 117-8000-557 Rev. A)

QTY	PART #	DESCRIPTION
1	053-0159-385	GRIP-SEAL BAG, PE, 60µm 160*220
4	311-4060-133K	SCREW SCKT CAP 8.8 M6X12
4	313-6000-010K	WASHER, DIN125, STEEL - M6, CLASS 2 COATING
4	311-4060-138K	SCREW SCKT CAP 8.8 M6X30
4	313-6002-010K	WASHER, LARGE, DIN9021, STEEL - M6, CLASS 2 COATING
4	312-6001-017K	HEX NUT NYLOCK DIN985 M6 CLASS 8
2	311-4055-182K	HEX BOLT DIN933 8.8 - M8X35
2	311-4055-178K	HEX BOLT DIN933 8.8 - M8X18
2	313-6001-013K	WASHER, SPRING LOCK, DIN127, STEEL - M8, CLASS 2
2	311-4060-137K	SCREW SCKT CAP 8.8 M6X25
2	312-6003-026K	HEX NUT COUP 6334-6 M8X1.25 ZN
4	311-4055-180K	HEX BOLT DIN933 M8X25
4	313-6000-013K	WASHER, DIN125, STEEL - M8, CLASS 2 COATING
4	312-6001-027K	HEX LOCK NUT NYLON INSERT DIN985 - 8 - M8

---

## UPDATES

Updates for Raven manuals as well as software updates for Raven consoles, and product controllers are available at the Applied Technology Division website:

<https://portal.ravenprecision.com>

Sign up for e-mail alerts to receive notifications when updates for your Raven products are available on the Raven website.

At Raven Industries, we strive to make your experience with our products as rewarding as possible. One way to improve this experience is to provide us with feedback on this manual.

Your feedback will help shape the future of our product documentation and the overall service we provide. We appreciate the opportunity to see ourselves as our customers see us and are eager to gather ideas on how we have been helping or how we can do better.

To serve you best, please send an email with the following information to

[techwriting@ravenind.com](mailto:techwriting@ravenind.com)

- RS1™ Installation Manual for Claas OSI Harvesters
- 016-5036-077 Rev. A
- Any comments or feedback (include chapter or page numbers if applicable).
- Let us know how long you have been using this or other Raven products.

We will not share your email or any information you provide with anyone else. Your feedback is valued and extremely important to us.

Thank you for your time.



---

**NOTE:** Prior to powering on the Raven RS1™, contact your local Claas dealer to install the Raven Steering unlock on the machine. The Claas ATP module will not communicate with the Raven RS1™ guidance controller without this unlock installed.

---

### LOCATE OSI CONNECTOR

1. Remove the lock-bolt and the panel from behind the operator seat.

**FIGURE 1. OSI Connector Cover Located Behind Operator Seat**

---





2. Locate the 6-pin Deutsch (OSI) connector behind the operator seat.

**FIGURE 2. OSI Connector**

---



**NOTE:** If this connector is not present, the machine is not steer-ready and RS1™ cannot be installed.

---

## PREPARATION

### PREPARE THE CAB

	<b>NOTICE</b>
Label and set aside OEM trim pieces and hardware for installation later.	

1. Remove the two lock screws and lift the armrest panel located to the right of the operator seat.

**FIGURE 3. Armrest Panel Lock Screw**



**NOTE:** It is recommended to open the right side window all the way to create enough space to remove the armrest panel.

2. Remove the four screw caps and screws securing the trim panel in the bottom, right, rear corner of the cab.

**FIGURE 4. Lower Corner Panel Cap and Screw Locations**

---



3. Remove the two screws located above the right, rear window.

**FIGURE 5. Upper Corner Panel Screw Locations**

---



4. Remove the corner trim panel from Figure 4 on page 14.

5. Locate the coat hanger on the right, rear B-pillar.
6. Press the top side of the coat hanger and remove it from the hanger mount.

**FIGURE 6. B-Pillar Coat Hook**



7. Remove the screw and the coat hanger bracket.

**FIGURE 7. B-Pillar Screw Locations**

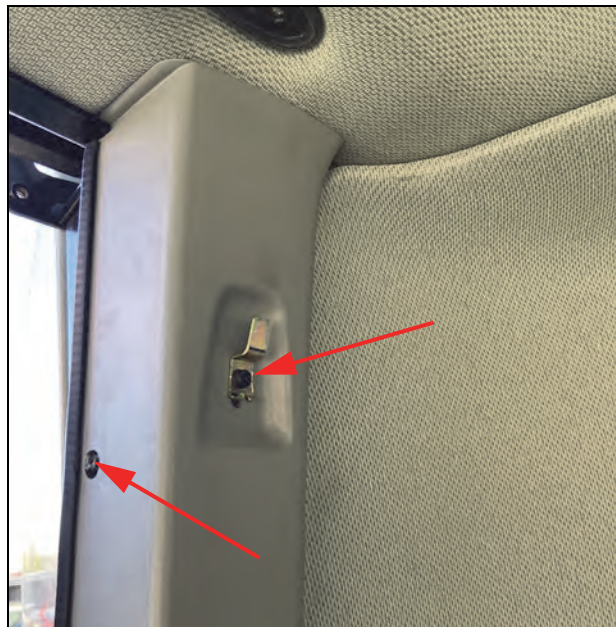

8. Remove the plastic cap on the side of the B-pillar.

9. The cab interior should appear similar to the picture below.

**FIGURE 8. B-Pillar and Corner Trim Panels Removed**

---



**NOTE:** If the machine is equipped with either a screen bar or cup holder, these pieces will need to be removed as well before removing the B-pillar.

10. Remove the air vent on the upper, right side of the cab.

**FIGURE 9. Air Vent Removed**

---



MOUNT THE DISPLAY BRACKET



NOTICE

Label and set aside OEM trim pieces and hardware for installation later.

1. Remove the four screws and the rectangular corner plate from the ceiling.

**FIGURE 10. A-Pillar and Plate Screws**



2. Remove the four screws (two screws on each side) in the ceiling next to the A-pillar.
3. Use the provided hardware included in the Claas OSI harvester mounting kit (P/N 117-8000-557) to attach the RAM® mount ball to the RAM® mounting bracket (P/N 107-0172-765).

**FIGURE 11. RAM® Mount Assembly**

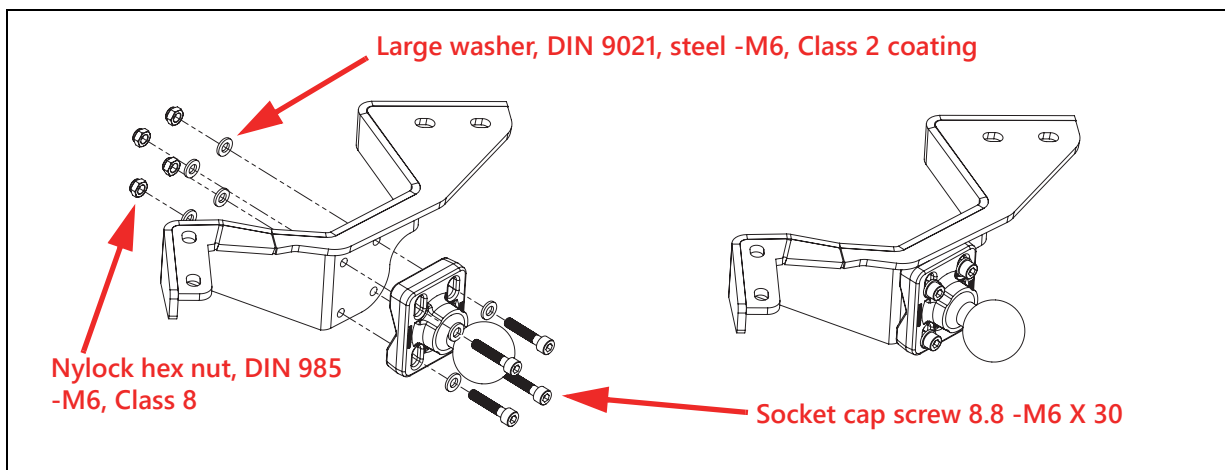

4. Mount the Claas Lexion RAM® mounting bracket in the top, right corner of the cab using the original screws. See Figure 10 on page 17.

**FIGURE 12. Display Bracket Mounted**

---



---

## ROUTE AND CONNECT THE IN CAB CABLING

1. Route the circular, 19-pin plug toward the ceiling via the B-pillar of the cab. Route over the ceiling via the air duct toward the right, front corner of the cab ceiling.

**NOTE:** This plug will connect to the field computer cables. Refer to *Install the Field Computer* section on page 23.

**FIGURE 13. Route the RS1 Cable Through the Cab Ceiling**

---



2. Connect the circular display panel mount connector on to the Claas display connector ceiling plate (P/N 107-0172-767).
3. Install the Claas display connector ceiling plate, to the original four holes in the ceiling using the original screws from Figure 10 on page 17.

**FIGURE 14. Display Connector Ceiling Plate Mounting Location**

---





4. Insert the OSI connector into the RS1™ cable (P/N 115-4010-253).

**FIGURE 15. OSI Connection**

---



SYSTEM DRAWINGS

FIGURE 16. RS1™ with CR7™ for Class OSI Harvesters System Drawing (P/N 054-5036-077 Rev. A)

SYSTEM DRAWING, CLAAS OSI HARVESTERS CR7 & RS1

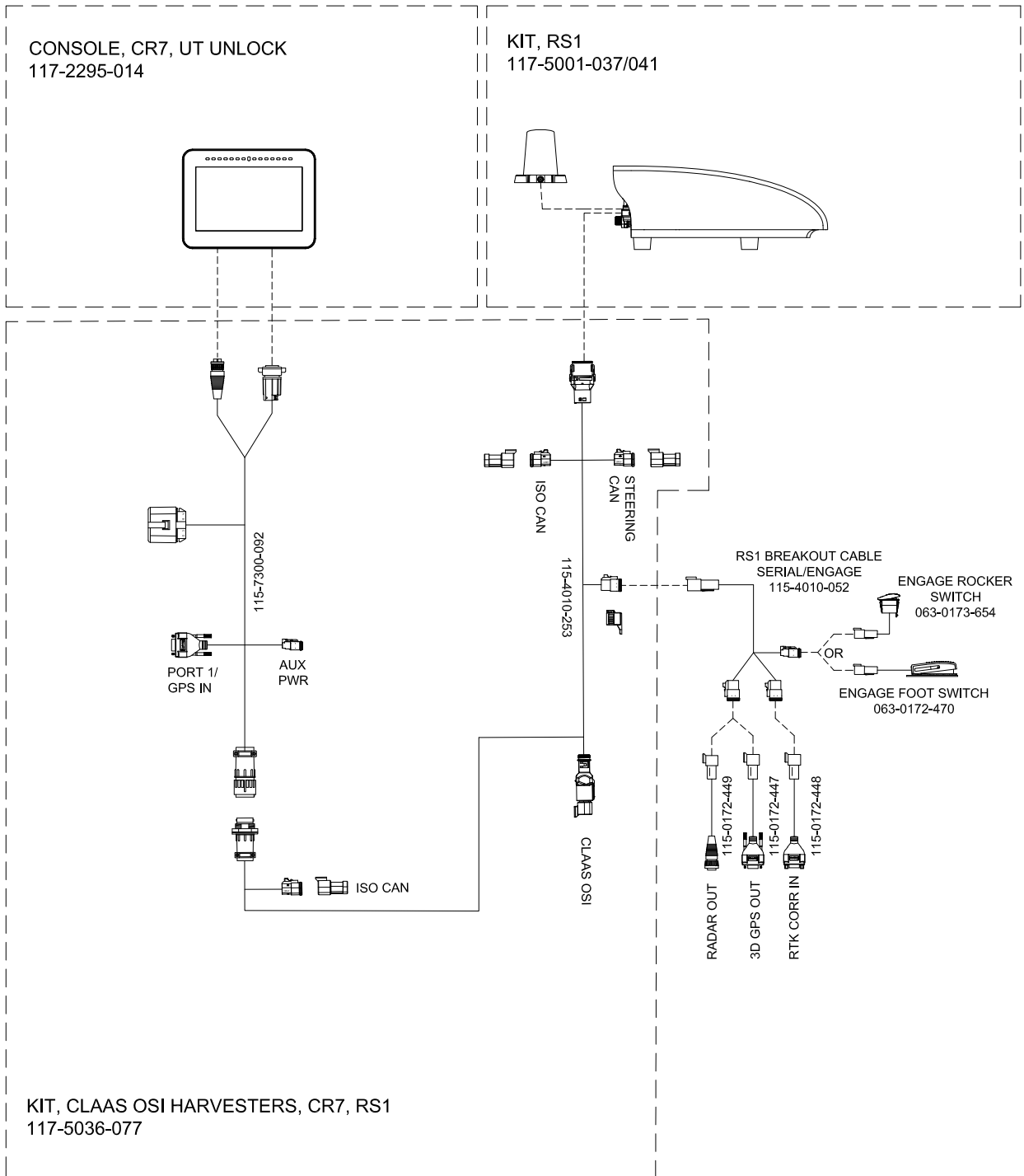
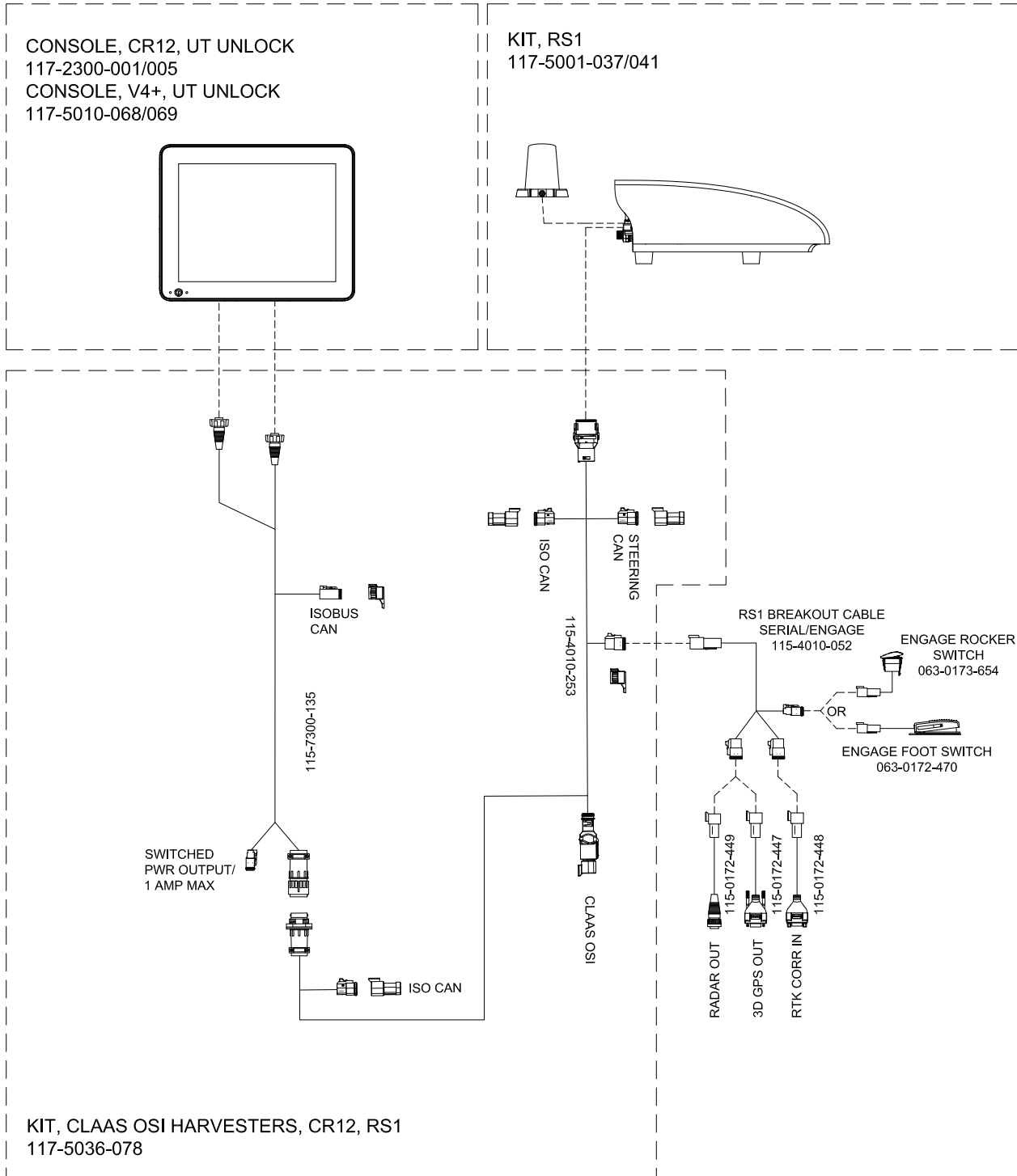

FIGURE 17. RS1™ with CR12™ or Viper® 4 for Class OSI Harvesters System Drawing (P/N 054-5036-078 Rev. A)

## SYSTEM DRAWING, CLAAS OSI HARVESTERS CR12 & RS1



## INSTALL THE FIELD COMPUTER

For best installation:

- Always ensure the terminal is placed in the most appropriate position facing the driver seat for easy access and use.
- Always use a RAM® C-ball attachment.
- Mount the terminal with a solid bracket in a place free of vibrations.
- Secure all cables in the cab so there are no free-hanging cables.
- Ensure the driver has a clear, unobstructed view all around the cab.

## MOUNT AND CONNECT THE FIELD COMPUTER

	<p><b>NOTICE</b></p> <p>Label and set aside OEM trim pieces and hardware for installation later.</p>
---	--

1. Secure all of the connections (cables, adapters) to the back of the field computer.

**FIGURE 1. Example of Field Computer Mounting**



**NOTE:** Securely mount the RAM® ball to the back of the field computer with socket arm to secure the device to the mounted plate.

**NOTE:** See the system diagrams Figure 16 on page 21, and Figure 17 on page 22 for more information.

---

## PREPARE EXTERNAL ROUTING

1. Locate the access panel just above the walkway on the right side of the cab.

**FIGURE 2. Walkway Access Panel**

---



2. Remove the two screws and open the access panel.

**FIGURE 3. Access Panel Screws**

---



3. Remove the three bolts and the pass-through plate from inside the right side panel.

**FIGURE 4. Remove the Pass-through Plate**

---

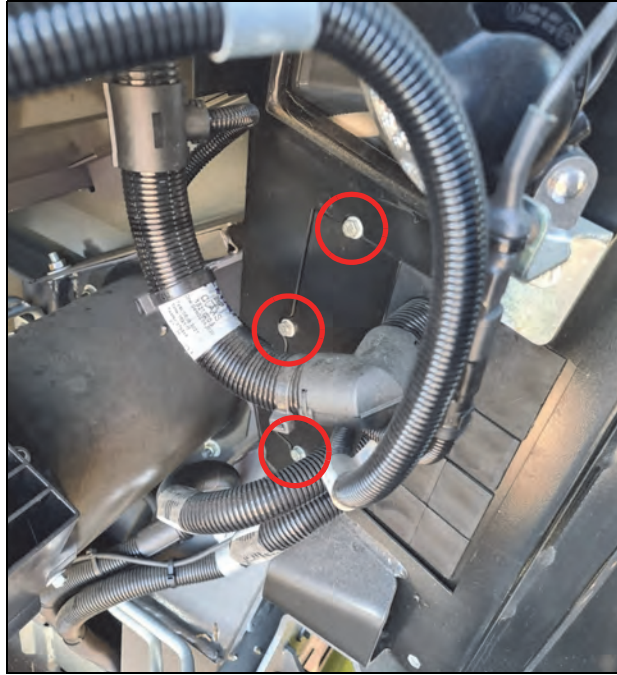

4. Remove the two bolts and open the roof hatch.

**FIGURE 5. Open Roof Hatch**

---



---

## MOUNT THE RS1™

**NOTE:** The RS1 may be mounted either with the stick-on kit (P/N 117-5001-058) or bolted through the cab roof.

### ROOF ACCESS AND PREP FOR MOUNTING HARDWARE

Complete the following steps to bolt the RS1 mounting bracket to the roof.

1. Locate the Lexion panel at the front of the cab next to the roof.
2. Remove the four bolts, (bolt location shown below with red arrows) two in the center, and one on each end from the Lexion panel.

**FIGURE 6. Lexion Roof Panel**

---



3. Loosen the hardware on the left side panel next to the Lexion panel.
4. Remove three bolts from the left side panel to gain enough space to remove the Lexion panel.
5. Remove the Lexion panel.

**FIGURE 7. Lexion Panel Removed**

---





6. The underside of the roof cover is accessible for the hardware to mount the RS1 mounting bracket.

**FIGURE 8. Underside of Roof Mounting Location for RS1™**

---



## SECURE THE RS1™ MOUNTING BRACKET

Complete the following steps to mount the RS1 mounting bracket to the roof.

**NOTE:** If using stick-on kit, it is not necessary to drill holes in the roof panel. Use adhesive strips provided to secure the RS1 mounting bracket to the roof.

1. Temporarily set the RS1™ mounting bracket in the center of the roof mounting area as shown in the image above.

**FIGURE 9. RS1™ Roof Top Mounting Location**



**NOTE:** Do not drill holes for, or adhere, the mounting bracket until the position of the bracket is confirmed.

2. Align the rear edge of the RS1 mounting bracket with the rear edge of the roof mounting area.

**NOTE:** Ensure that the RS1 mounting bracket does not interfere with the removable roof panel. Keep the RS1 mounting bracket flush with or slightly ahead of the rear edge of the roof mounting location.

3. If mounting the bracket with hardware, use the holes in the RS1 mounting bracket as a template to mark and drill four M8 holes through the roof cover.

4. Use the provided hardware, or adhesive tape, included in the Claas OSI harvester mounting kit to attach the lower half of the RS1™ mounting bracket to the roof.

FIGURE 10. Lower RS1™ Mounting Bracket With Stick-on Kit

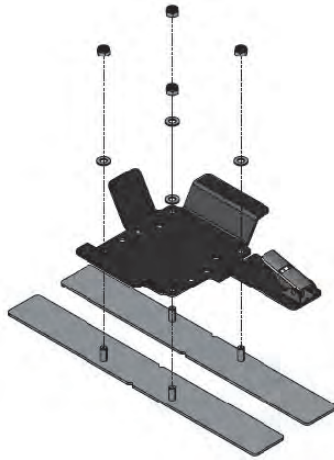

**NOTE:** The mount stays permanently attached to the roof of the tractor.

FIGURE 11. RS1™ Bracket Mounted With Hardware

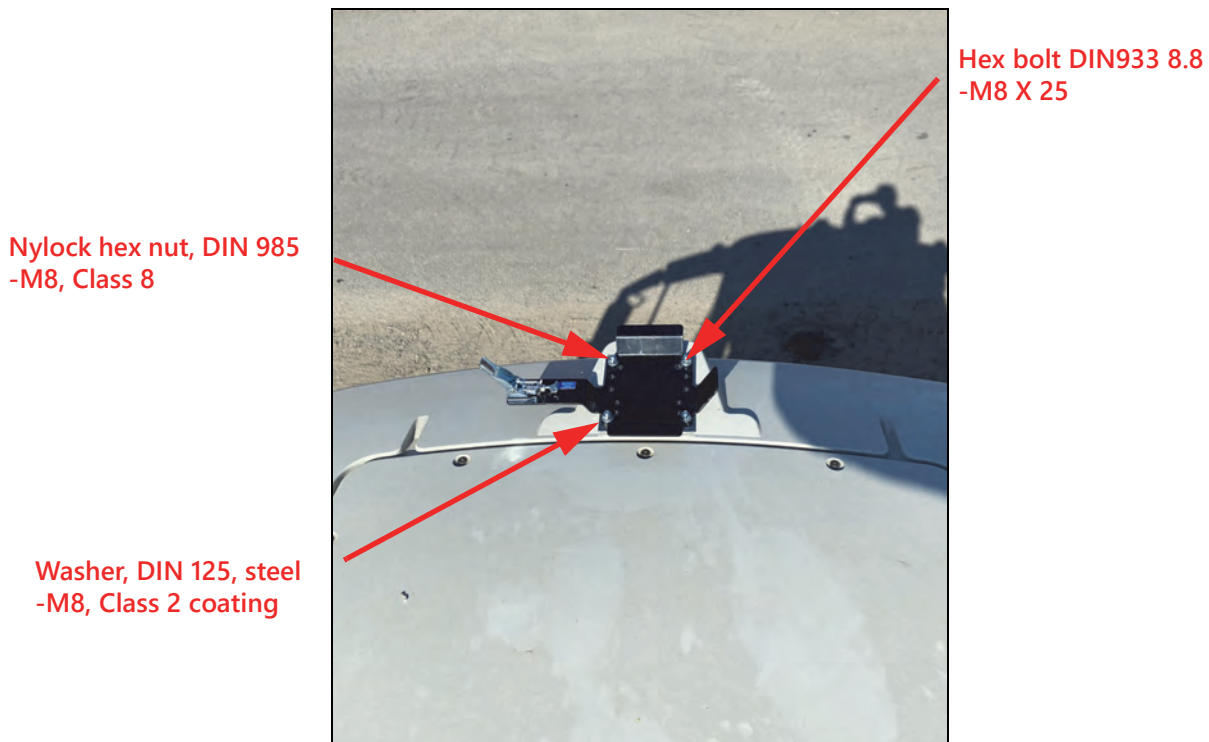

5. Mount the latch plate onto the RS1™ using the provided screws.
6. Secure the RS1™, already connected to the latch plate, onto the fixed plate.

**FIGURE 12. RS1™ Mounted on Generic Bracket**

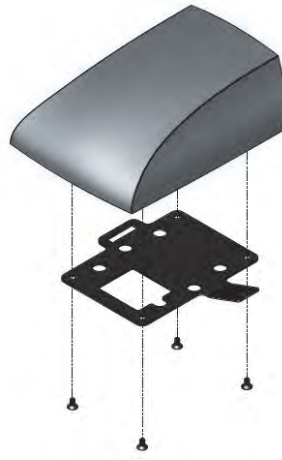

**NOTE:** This latch plate stays connected to the RS1™.

7. Secure the assembly with the latch.

**FIGURE 13. RS1™ Mounted**



## ROUTE AND CONNECT THE OUT OF CAB CABLING

1. Use the space created in the lower, right corner of the cab to route the RS1™ cable to outside of the cab.

**FIGURE 14. Lower Corner Panel Space To Outside**

---



2. Route the RS1™ cable through the gap below the air conditioning hoses at the top of the access panel area.

**FIGURE 15. RS1™ Cable Routing**

---

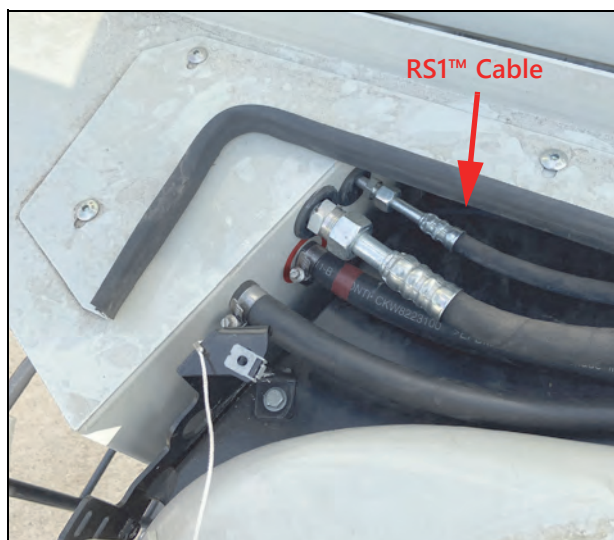

3. Route the RS1™ cable toward the center rear of the roof hatch.

**FIGURE 16. RS1™ Cable Routing**

---



4. Route the RS1™ cable under the rubber seal of the roof hatch and install the roof hatch.
5. Connect the 12-pin connector to the back of the RS1™.



---

## CHAPTER

# 5

## ACTIVATE AUTOMATIC STEERING

---

**NOTE:** Prior to powering on the Raven RS1™, contact your local Claas dealer to install the Raven Steering unlock on the machine. The Claas ATP module will not communicate with the Raven RS1™ guidance controller without this unlock installed.

---

### ACTIVATE AUTOMATIC STEERING

To activate automatic steering for Claas OSI systems with RS1™:

**NOTE:** Verify that the machine is unlocked for third-party steering from Raven.

1. For a combine harvester like the Lexion, Trion, Tucano, Avero make sure to first open the grain tank.

**NOTE:** These four steps need to be done before the ATP module from Claas can allow a third-party to perform automatic steering.

Automatic steering must be engaged via the engage button on the joystick. Steering widgets on the display will not engage autosteering functionality in this application. This also accounts for teaching in the engage button, and auto-calibration (these are steps in the calibration procedure of the machine). The step response test is also not possible on a Claas OSI machine.

**FIGURE 1. Road Switch**





2. Toggle the road switch into field mode.

**FIGURE 2. PTO Switch**

---



3. Toggle the PTO switch to engage equipment harvesting operation.

**FIGURE 3. Auto-steer Button on Joystick**

---



4. Press the auto-steer button on the joystick to turn on automatic steering.

# LIMITED WARRANTY

## WHAT DOES THIS WARRANTY COVER?

This warranty covers all defects in workmanship or materials in your Raven Applied Technology Division product under normal use, maintenance, and service when used for intended purpose.

## HOW LONG IS THE COVERAGE PERIOD?

Raven Applied Technology products are covered by this warranty for 12 months from the date of retail sale. In no case will the Limited Warranty period exceed 36 months from the date the product was issued by Raven Industries Applied Technology Division. This warranty coverage applies only to the original owner and is non-transferable.

## HOW CAN I GET SERVICE?

Bring the defective part and proof of purchase to your Raven dealer. If the dealer approves the warranty claim, the dealer will process the claim and send it to Raven Industries for final approval. The freight cost to Raven Industries will be the customer's responsibility. The Return Materials Authorization (RMA) number must appear on the box and all documentation (including completed RMA form, Certificate of Decontamination, and retail proof of purchase) must be included inside the box to be sent to Raven Industries.

## WHAT WILL RAVEN INDUSTRIES DO?

Upon confirmation of the warranty claim, Raven Industries will (at our discretion) repair or replace this product or any component of the product found to be defective during the warranty period. Replacement will be made with a new or remanufactured product or component. Standard return freight will be paid, regardless of inbound shipping method. Expedited freight is available at the customer's expense.

## WHAT IS NOT COVERED BY THIS WARRANTY?

Raven Industries will not assume any expense or liability for repairs outside our facility without written consent. Raven Industries is not responsible for damage to any associated equipment or products and will not be liable for loss of profit, labor, or other damages. The obligation of this warranty is in lieu of all other warranties, expressed or implied, and no person or organization is authorized to assume any liability for Raven Industries.

- Damages caused by normal wear and tear, misuse, abuse, neglect, accident, improper installation and maintenance are not covered by this warranty.
- Worn/Chafed hoses and cables.
- Items in contact with fluids and chemicals including seals and O-rings.
- Software downloads and updates.
- Tamper-Evident label broken or customer disassembly.
- Any customer modification to the original product outside normal calibration and adjustments, without written approval.
- Intentional modification to cables.
- Failures due to lack of cleaning or preventive maintenance, and any condition, malfunction or damage not resulting from defects in material or workmanship.
- Items in contact with fluids or chemicals, returned without proper cleaning, decontamination and documentation.

# EXTENDED WARRANTY

## WHAT DOES THIS WARRANTY COVER?

This warranty covers all defects in workmanship or materials in your Raven Applied Technology Division product under normal use, maintenance, and service when used for intended purpose.

## DO I NEED TO REGISTER MY PRODUCT TO QUALIFY FOR THE EXTENDED WARRANTY?

Yes. Products/systems must be registered within 30 days of retail sale to receive coverage under the Extended Warranty. If the component does not have a serial tag, the kit it came in must be registered instead.

## WHERE CAN I REGISTER MY PRODUCT FOR THE EXTENDED WARRANTY?

To register, go online to <https://portal.ravenprecision.com> and select Product Registration.

## HOW LONG IS THE EXTENDED WARRANTY COVERAGE PERIOD?

Raven Applied Technology products that have been registered online are covered for an additional 12 months beyond the Limited Warranty for a total coverage period of 24 months from the date of retail sale. In no case will the Extended Warranty period exceed 36 months from the date the product was issued by Raven Industries Applied Technology division. This Extended Warranty coverage applies only to the original owner and is non-transferable.

## HOW CAN I GET SERVICE?

Bring the defective part and proof of purchase to your Raven dealer. If the dealer approves the warranty claim, the dealer will process the claim and send it to Raven Industries for final approval. The freight cost to Raven Industries will be the customer's responsibility. The Return Materials Authorization (RMA) number must appear on the box and all documentation (including completed RMA form, Certificate of Decontamination, and Extended Warranty Registration Number) must be included inside the box to be sent to Raven Industries. In addition, the words "Extended Warranty" must appear on the box and all documentation if the failure is between 12 and 24 months from the retail sale.

## WHAT WILL RAVEN INDUSTRIES DO?

Upon confirmation of the warranty claim, Raven Industries will (at our discretion) repair or replace this product or any component of the product found to be defective during the warranty period. Replacement will be made with a new or remanufactured product or component. Standard return freight will be paid, regardless of inbound shipping method. Expedited freight is available at the customer's expense.

## WHAT IS NOT COVERED BY THE EXTENDED WARRANTY?

Raven Industries will not assume any expense or liability for repairs outside our facility without written consent. Raven Industries is not responsible for damage to any associated equipment or products and will not be liable for loss of profit, labor, or other damages. The obligation of this warranty is in lieu of all other warranties, expressed or implied, and no person or organization is authorized to assume any liability for Raven Industries.

- Damages caused by normal wear and tear, misuse, abuse, neglect, accident, improper installation and maintenance are not covered by this warranty.
- Worn/Chafed hoses and cables.
- Items in contact with fluids and chemicals including seals and O-rings.
- Software downloads and updates.
- Tamper-Evident label broken or customer disassembly.
- Any customer modification to the original product outside normal calibration and adjustments, without written approval.
- Intentional modification to cables.
- Failures due to lack of cleaning or preventive maintenance, and any condition, malfunction or damage not resulting from defects in material or workmanship.
- Items in contact with fluids or chemicals, returned without proper cleaning, decontamination and documentation.