

Hawkeye® 2 Installation  
Manual for AGCO RoGator  
C-Series (RG900, RG1100,  
RG1300)

016-0171-712 Rev. B

1/2021

E36827



## DISCLAIMER

While every effort has been made to ensure the accuracy of this document, Raven Industries assumes no responsibility for omissions and errors. Nor is any liability assumed for damages resulting from the use of information contained herein.

Raven Industries shall not be responsible or liable for incidental or consequential damages or a loss of anticipated benefits or profits, work stoppage or loss, or impairment of data arising out of the use, or inability to use, this system or any of its components. Raven Industries shall not be held responsible for any modifications or repairs made outside our facilities, nor damages resulting from inadequate maintenance of this system.

As with all wireless and satellite signals, several factors may affect the availability and accuracy of wireless and satellite navigation and correction services (e.g. GPS, GNSS, SBAS, etc.). Therefore, Raven Industries cannot guarantee the accuracy, integrity, continuity, or availability of these services and cannot guarantee the ability to use Raven systems, or products used as components of systems, which rely upon the reception of these signals or availability of these services. Raven Industries accepts no responsibility for the use of any of these signals or services for other than the stated purpose.

## Table of Contents

---

<b>Chapter 1</b>	<b>Important Information.....</b>	<b>1</b>
Safety .....		<b>1</b>
Agricultural Chemical Safety .....		<b>2</b>
Electrical Safety .....		<b>2</b>
Recommendations and Best Practices .....		<b>3</b>
Harness Routing .....		<b>3</b>
<b>Chapter 2</b>	<b>Introduction.....</b>	<b>5</b>
Make and Model Compatibility .....		<b>5</b>
Nozzle Spacing .....		<b>6</b>
Machine Configuration Notes .....		<b>6</b>
Installation Overview .....		<b>7</b>
Required Components .....		<b>7</b>
Tools and Materials Needed .....		<b>7</b>
Point of Reference .....		<b>7</b>
Kit Contents .....		<b>8</b>
Updates .....		<b>19</b>
<b>Chapter 3</b>	<b>Installation Preparation .....</b>	<b>21</b>
<b>Chapter 4</b>	<b>Nozzle Body and Nozzle Control Valve Installation .....</b>	<b>23</b>
Hawkeye® 2 Nozzle Body Installation .....		<b>23</b>
Best Practices and Recommendations .....		<b>23</b>
Hypro Nozzle Body Installation .....		<b>23</b>
Wilger Nozzle Body Assembly & Installation .....		<b>24</b>
Install the ProStop-E Valve .....		<b>28</b>
Nozzle Control Valve 2 (NCV2) Installation .....		<b>31</b>
Boom Cable Routing and Connection .....		<b>31</b>
Best Practices and Recommendations .....		<b>31</b>
Boom Cable Routing and Connections (Inner, Middle, and Outer Boom Cables) .....		<b>32</b>
<b>Chapter 5</b>	<b>Install the Hawkeye® 2 RCM - Sprayer .....</b>	<b>33</b>
RCM - Sprayer Installation .....		<b>33</b>
Best Practices and Recommendations .....		<b>33</b>
RCM - Sprayer Mounting Location .....		<b>33</b>
ECU Cabinet Preparation .....		<b>37</b>
In Cab Connections .....		<b>42</b>
<b>Chapter 6</b>	<b>Chassis Cable Installation.....</b>	<b>43</b>
Chassis Cable Routing and Connection .....		<b>43</b>
Best Practices and Recommendations .....		<b>43</b>
ECU Cabinet to RCM - Sprayer Connections .....		<b>43</b>
Hawkeye® 2 ECU NCV Power Cable Installation .....		<b>44</b>
Hawkeye® 2 Power Connections (No Injection) .....		<b>45</b>
System Diagrams .....		<b>45</b>

**Table of Contents**

---

**Chapter 7 Sidekick Pro™ ICD Installation..... 49**

- Sidekick Pro ICD Connections to CANbus Hub .....**49**
- Sidekick Pro ICD Cable to Pump Connections .....**50**
- Sidekick Pro ICD Power Supply .....**51**

**Appendix A Cable and Connector Maintenance ..... 53**

- Power and ECU Harness Maintenance .....**53**
- Hawkeye® 2 Boom Harness Connector Maintenance .....**53**

**Appendix B Special Configuration for ProStop-E Combination Kits..... 57**

- Section Widths .....**57**
- Switch Mapping .....**58**

## SAFETY

### **NOTICE**

Follow the operation and safety instructions included with the implement and/or controller and read this manual carefully before installing or operating this Raven system.

- Follow all safety information presented within this manual. Review implement operation with your local dealer.
- Contact a local Raven dealer for assistance with any portion of the installation, service, or operation of Raven equipment.
- Follow all safety labels affixed to system components. Be sure to keep safety labels in good condition and replace any missing or damaged labels. Contact a local Raven dealer to obtain replacements for safety labels.

Observe the following safety measures when operating the implement after installing this Raven system:

- Do not operate this Raven system or any agricultural equipment while under the influence of alcohol or an illegal substance.
- Be alert and aware of surroundings and remain in the operator seat at all times when operating this Raven system.
  - Do not operate the implement on any public road with this Raven system enabled.
  - Disable this Raven system before exiting the operator seat.
  - Determine and remain a safe working distance from obstacles and bystanders. The operator is responsible for disabling the system when a safe working distance has diminished.
  - Disable this Raven system prior to starting any maintenance work on the implement or components of this Raven system.
- Do not attempt to modify or lengthen any of the system control cables. Extension cables are available from a local Raven dealer.

## **WARNING**

### AGRICULTURAL CHEMICAL SAFETY

Follow all federal, state, and local regulations regarding the handling, use, and disposal of agricultural chemicals, products, and containers. Triple-rinse and puncture or crush empty containers before properly disposing of them. Contact a local environmental agency or recycling center for additional information.

- Always follow safety labels and instructions provided by the chemical manufacturer or supplier.
- Always wear appropriate personal protective equipment as recommended by the chemical and/or equipment manufacturer.
- When storing unused agricultural chemicals:
  - Store agricultural chemicals in the original container and do not transfer chemicals to unmarked containers or containers used for food or drink.
  - Store chemicals in a secure, locked area away from human and livestock food.
  - Keep children away from chemical storage areas.
- Fill, flush, calibrate, and decontaminate chemical application systems in an area where runoff will not reach ponds, lakes, streams, livestock areas, gardens, or populated areas.
- Follow all label instructions for chemical mixing, handling, and disposal.
- Avoid direct contact with agricultural chemicals or inhaling chemical dust or spray particulate. Seek immediate medical attention if symptoms of illness occur during, or soon after, use of agricultural chemicals or products.
- After handling or applying agricultural chemicals:
  - Thoroughly wash hands and face after using agricultural chemicals and before eating, drinking, or using the restroom.
  - Thoroughly flush or rinse equipment used to mix, transfer, or apply chemicals with water after use or before servicing any component of the application system.

## **CAUTION**

### ELECTRICAL SAFETY

- Always verify that power leads are connected to the correct polarity as marked. Reversing the power leads could cause severe damage to the Raven system or other components.
- To prevent personal injury or fire, replace defective or blown fuses with only fuses of the same type and amperage.
- Do not connect the power leads to the battery until all system components are mounted and all electrical connections are completed.
- Always start the machine before initializing this Raven system to prevent power surges or peak voltage.
- To avoid tripping and entanglement hazards, route cables and harnesses away from walkways, steps, grab bars, and other areas used by the operator or service personnel when operating or servicing the equipment.

---

## RECOMMENDATIONS AND BEST PRACTICES

### HARNESS ROUTING

The word “harness” is used to describe any electrical cables and leads, both bundled and unbundled. Use the following guidelines and recommendations when connecting and routing harnesses while installing or maintaining this Raven system:

- Leave protective caps/covers over harness connectors until needed to avoid dirt and moisture from contaminating electrical circuits.
- Secure the harness to the frame or solid structural members at least every 12 in [30 cm].
- Follow existing harness runs already routed on the implement as much as possible. Proper harness routing should:
  - Secure harnessing and prevent the harness from hanging below the implement.
  - Provide sufficient clearance from moving components and operational zones around shafts; universal joints and suspension components; pulleys, gears, belts, and chains; moving linkages, cylinders, articulation joints, etc.
  - Protect harnessing from field debris and surrounding hazards (e.g. tree limbs, fence posts, crop stubble, dirt clumps or rocks that may fall or be thrown by the implement).
  - Protect harnessing from sharp bends, twisting, or flexing over short distances and normal implement operation.
  - Connectors and splices should not be located at bending points or in harness sections that move.
  - Ensure sufficient length for free movement of the implement during normal operation and prevent pulling, pinching, catching, or rubbing, especially in articulation and pivot points. Clamp harnessing securely to force controlled movement of the harness.
  - Avoid abrasive surfaces and sharp edges such as sheared or flame cut corners, fastener threads or cap screw heads, hose clamp ends, etc.
- Do not connect, affix, or allow harnessing to come into contact with components with high vibration forces, hot surfaces, or components carrying hot fluids beyond the temperature rating of harness components.
  - Harnessing should be protected or shielded if routing requires the hose to be exposed to conditions beyond harnessing component specifications.
- Avoid routing harnesses in areas where damage may occur due to build up of material (e.g. dirt, mud, snow, ice, etc.).
- Avoid routing harnesses in areas where the operator or service personnel might step or use as a grab bar.

**IMPORTANT:** Avoid applying direct spray or pressure washing of electrical components and connections. High pressure streams and sprays can penetrate seals, cause corrosion, or otherwise damage electrical components. When performing maintenance:

- Inspect electrical components and connectors for corrosion, damaged pins or housings, etc. Repair or replace components or harnessing as necessary.
- Ensure connectors are kept clean and dry. Apply dielectric grease to the sealing surfaces of all connections exposed to moisture, dirt, debris, and other contaminants. Repair or replace harnessing as necessary.
- Clean electrical components with pressurized air, aerosol electrical cleaning agent, or low pressure rinse.
- Remove visible surface water from electrical components and connections using pressurized air or an aerosol cleaning agent. Allow components to dry thoroughly before reconnecting cables.





# CHAPTER

# INTRODUCTION

## 2

### MAKE AND MODEL COMPATIBILITY

Hawkeye® 2 is a pressure-based product control system which allows for precise sprayer application over a range of conditions and reduced spray drift. Each nozzle is controlled by an individual pulsing valve giving you a consistent spray pattern as speed and conditions change.

Hawkeye® 2 is built on the ISOBUS communication platform which allows the system to work with most ISO Universal Terminals (UTs) and task controllers, including the Viper® 4.

This manual is intended to provide installation instructions on the following equipment:

TABLE 1. Compatible Equipment Information

Make and Model	Nozzle Spacing	Boom Width	Nozzle Body Type	Kit Number
AGCO RoGator C-Series (RG900C, RG1100C, RG1300C)	20"	132'	Wilger with ProStop-E	117-2005-100
			Hypro	117-2005-104
		120'	Wilger with ProStop-E	117-2005-101
			Hypro	117-2005-105
		100'	Wilger with ProStop-E	117-2005-102
			Hypro	117-2005-106
	90'	Wilger with ProStop-E	117-2005-103	
		Hypro	117-2005-107	
	19"	132'	Hypro	117-2005-108
		120'	Hypro	117-2005-109
		100'	Hypro	117-2005-110
	15"	120'	Wilger with ProStop-E	117-2005-112
			Hypro	117-2005-115
		100'	Wilger with ProStop-E	117-2005-113
			Hypro	117-2005-116
		90'	Wilger with ProStop-E	117-2005-114
			Hypro	117-2005-117
	10"	120'	Hypro	117-2005-118

## NOZZLE SPACING

The information in the table below is required for the machine configuration process on the Universal Terminal. Refer to the Hawkeye® 2 Calibration and Operation Manual for machine assistance with system setup or operation.

TABLE 2. Section Widths Per Boom Width and Nozzle Spacing

Section Number	132' Boom		120' Boom			100' Boom			90' Boom	
	Nozzle Spacing		Nozzle Spacing			Nozzle Spacing			Nozzle Spacing	
	19"	20"	15"	19"	20"	15"	19"	20"	15"	20"
1	76"	80"	60"	114"	60"	45"	76"	40"	15"	20"
2	76"	80"	90"	133"	80"	60"	76"	60"	30"	20"
3	133"	120"	90"	76"	80"	60"	76"	60"	60"	20"
4	114"	120"	90"	76"	120"	60"	76"	80"	60"	30"
5	133"	120"	60"	114"	80"	90"	76"	60"	90"	30"
6	114"	100"	135"	76"	120"	90"	76"	120"	90"	60"
7	114"	120"	135"	76"	120"	135"	95"	120"	135"	60"
8	95"	60"	105"	95"	60"	105"	95"	60"	105"	30"
9	114"	60"	135"	76"	60"	135"	95"	60"	135"	30"
10	114"	120"	135"	76"	120"	90"	76"	120"	90"	60"
11	133"	100"	60"	114"	120"	90"	76"	120"	90"	60"
12	114"	120"	90"	76"	80"	60"	76"	60"	60"	30"
13	133"	120"	90"	76"	120"	60"	76"	80"	60"	30"
14	76"	120"	90"	133"	80"	60"	76"	60"	30"	20"
15	76"	80"	60"	114"	80"	45"	76"	60"	15"	20"
16	-	80"	-	-	60"	-	-	40"	-	20"

## MACHINE CONFIGURATION NOTES

- It is not necessary to check the fence row option as this functionality is controlled via AGCO switches and cabling.
- When prompted to enter the number of sections and section widths in the wizard. Refer to Table 2 on page 6 for sections and section widths.
- Do not modify the switch mapping because Hawkeye® 2 will auto-fill the switch mapping values. The sections will map the same number of switches as there are sections.
- The AGCO AccuTerminal does not need to have settings changed to function with Hawkeye® 2.
- The AGCO AccuTerminal and other ECUs should be updated to the latest software by an AGCO Service Provider.

---

## INSTALLATION OVERVIEW

The recommended process for installing the Hawkeye® 2 nozzle control system is as follows:

1. Confirm Hawkeye® 2 kit contents. See the *Kit Contents* section on page 8.
2. Replace existing strainer with an 80 mesh (or finer) strainer. See the *Hawkeye Installation Preparation* section on page 7.
3. Remove spray tips and flush each section individually for a minimum of 20 seconds to thoroughly flush the boom.
4. Assemble nozzle bodies (Wilger kits only) and install provided nozzle bodies as needed.
5. Mount Hawkeye® 2 nozzle control valves. See the Chapter 4, *Nozzle Body and Nozzle Control Valve Installation*.
6. Mount the RCM - Sprayer. See the *RCM - Sprayer Installation* section on page 33.
7. Route and connect the inner, mid, and outer boom cables (as applicable). See the *Boom Cable Routing and Connection* section on page 10.
8. Route and connect chassis and RCM - Sprayer cables. See the *Chassis Cable Routing and Connection* section on page 19.
9. Review the Post-Installation Notes for machine configuration tips.

## REQUIRED COMPONENTS

The following components must be installed with the Hawkeye® 2 nozzle control system:

- Updated software on field computers or control monitors and other ECUs. Contact your local AGCO dealer for the latest software.
- PWM pump control valve
- Raven compatible flow meter
- Raven compatible pressure transducer
- 80 mesh (or finer) strainer

**NOTE:** A fan or cone style spray tip is recommended for the Hawkeye® 2 system to operate properly. Air induction tips are not recommended for use with the nozzle control system.

## TOOLS AND MATERIALS NEEDED

The following tools are recommended for completing the installation:

- SAE and metric sized wrenches and tools
- 1-1/2" hole saw
- Drill bit set and drill
- CorrosionX HD (recommended) or other dielectric contact treatment
- Cable ties (supplied)
- Phillips screwdriver
- Side cutters

## POINT OF REFERENCE

The instructions provided in this manual assume the installer is standing behind the machine, looking toward the machine cabin.

## KIT CONTENTS

TABLE 3. Kit Contents for AGCO RoGator C-Series Equipment with Wilger Nozzle Bodies

Picture	Item Description	Part Number	Qty.						
			117-2005-						
			100	101	102	103	112	113	
	Sheet, Warranty/ Help	016-0171-649		1					
	RCM - Sprayer	063-0173-956	1	1	1	1	1	1	1
	Cable, RoGator C, Hawkeye 2, ECU Cabinet	115-2005-017	1	1	1	1	1	1	1
	Cable, RoGator C Bulkhead Hawkeye 2	115-2005-018	1	1	1	1	1	1	1
	Cable, RoGator C, ECU Cabinet to RCM - Sprayer	115-2005-019	1	1	1	1	1	1	1
	Cable, RoGator C Mid Hawkeye 2	115-2005-003		2					
	Cable, RoGator C Outer Hawkeye 2	115-2005-004		2					
	Cable, Inner, 132'/20", AGCO, Millenium Boom, Hawkeye 2	115-2005-159	2						
	Cable, Mid, 132'/20", AGCO, Millenium Boom, Hawkeye 2	115-2005-160	2						

Picture	Item Description	Part Number	Qty.						
			117-2005-						
			100	101	102	103	112	113	
	Cable, Outer, 132'/20", AGCO, Millenium Boom, Hawkeye 2	115-2005-161	2						
	Cable, Left Inner, 120'/15", RoGator C, Hawkeye 2	115-2005-183						1	
	Cable, Right Inner, 120'/15", RoGator C, Hawkeye 2	115-2005-184						1	
	Cable, Outer, 120'/15", RoGator C, Hawkeye 2	115-2005-186						2	
	Cable, Left Inner, 100'/15", RoGator C, Hawkeye 2	115-2005-187							1
	Cable, Right Inner, 100'/15", RoGator C, Hawkeye 2	115-2005-188							1
	Cable, Mid, 100'/15", RoGator C, Hawkeye	115-2005-189							2
	Cable, Outer, 100'/15", RoGator C, Hawkeye 2	115-2005-190							2
	Cable, Inner, 100'/20", AGCO, Hawkeye 2	115-2005-123			2	2			
	Cable, Mid, 100'/20", AGCO, Hawkeye 2	115-2005-124			2	2			

Picture	Item Description	Part Number	Qty.					
			117-2005-					
			100	101	102	103	112	113
	Cable, Outer, 100'/20", AGCO, Hawkeye 2	115-2005-125			2			
	Cable, Outer, 90'/20", AGCO, Hawkeye 2	115-2005-205				2		
	Kit, Hawkeye 2 Wilger Service	117-2005-052	1	1	1	1	1	1
	Plate, RoGator C REM/ABM Mounting	107-0235-015	1	1	1	1	1	1
	Fuse, 70A Bolt Down MIDI/AMI	510-1003-048	1	1	1	1	1	1
	Nut, M5 Flange Nylon Lock	312-4000-215	2	2	2	2	2	2
	Nut, M8 Flange Nylon Lock	312-4000-217	1	1	1	1	1	1
	Bolt, M6-1, x 75mm (G8-Class II Coating)	311-4050-147K	2	2	2	2	2	2
	Bolt, M6-1, x 65mm (G8-Class II Coating)	311-4050-145K	1	1	1	1	1	1
	Bolt, M6-1, x 110mm (G8 - Class II Coating)	331-40050-154K	1	1	1	1	1	1
	Bolt, M6-1 x 140mm (G8 - Class II Coating)	331-4050-159K	2	2	2	2	2	2
	Nut, M6-1 Flanged Zinc Nyloc	312-4000-216	3	3	3	3	3	3
	Washer, M6 Zinc	313-1000-046	3	3	3	3	3	3

Picture	Item Description	Part Number	Qty.					
			117-2005-					
			100	101	102	103	112	113
	Spacer, RoGator Boom Bump Stop	107-0172-609		4	4	4	4	4
	Bolt, M6 x 1.0 x 75 Stainless Steel Hex	311-4058-147		12	12	12	12	12
	U-Bolt, Zinc 4-1/16"W x 3" L x 3/8"-16 UNC	107-0171-852	2	2	2	2	2	2
	Nut, 3/8"-16 Zinc Flanged Lock	312-1001-164	4	4	4	4	4	4
	Cable, RoGator 1300 Primary Hawkeye 2	115-2005-002		2				
	NCV, Wilger Hawkeye 2	063-2005-003	80	72	60	54	95	80
	O-Ring, Size - 116 Black Viton	219-2005-116	10		25	19	24	9
	O-Ring, Size - 116 Black Viton (38-pack)	219-2005-116M	2	2	1	1	2	2
	Plug, C/C Wilger Male Adapter	333-0002-319	82	13	13	13	18	18
	Assembly, Wilger Combo-Jet to SS	333-0002-322	164	146	120	122	192	162
	End Nozzle Body, Wilger Blended Pulse	333-0002-325		73	61	55	97	82
	Nozzle Body, 2-Way 1" (3/8" Inlet Mod)	333-0002-332	82	13	13	13	18	18
	Nozzle Body, 5-Way Turret, Side Take-Off, without Cap, Wilger	333-0002-354	82					

Picture	Item Description	Part Number	Qty.					
			117-2005-					
			100	101	102	103	112	113
	Adapter, Prostop-E to Wilger Nozzle Body	063-0173-964	82	73	61	55	97	82
	Nozzle Body, Wilger No On/Off Cap Through	333-0002-349		61	49	43	82	66
	Tube, Wiler 1" (3/8" Inlet) Saddle w/o Nozzle	333-0002-350		61	49	43	82	66

TABLE 4. Kit Contents for AGCO RoGator C-Series Equipment with Hypro Nozzle Bodies

Picture	Item Description	Part Number	Qty.										
			117-2005-										
			104	105	106	107	108	109	110	115	116	118	
	Sheet, Warranty/ Help	016-0171-649					1						
	RCM - Sprayer	063-0173-956	1	1	1	1	1	1	1	1	1	1	1
	Cable, Mid, 120'/20", AGCO, Hawkeye 2	115-2005-003		2									
	Cable, Outer, 120'/20", AGCO, Hawkeye 2	115-2005-004		2									
	Cable, RoGator C, Hawkeye 2, ECU Cabinet	115-2005-017	1	1	1	1	1	1	1	1	1	1	1
	Cable, RoGator C Bulkhead Hawkeye 2	115-2005-018	1	1	1	1	1	1	1	1	1	1	1



Picture	Item Description	Part Number	Qty.										
			117-2005-										
			104	105	106	107	108	109	110	115	116	118	
	Cable, RoGator C, ECU Cabinet to RCM - Sprayer	115-2005-019	1	1	1	1	1	1	1	1	1	1	1
	Cable, Mid, 100'/20", AGCO, Hawkeye 2	115-2005-124			2	2							
	Cable, Outer, 100'/20", AGCO, Hawkeye 2	115-2005-125			2								
	Cable, AGCO 132'/19" Mid Hawkeye 2	115-2005-153					2						
	Cable, AGCO 132'/19" Outer Hawkeye 2	115-2005-154					2						
	Cable, Mid, 132'/20", AGCO, Millenium Boom, Hawkeye 2	115-2005-160	2										
	Cable, Outer, 132'/20" AGCO, Millenium Boom, Hawkeye 2	115-2005-161	2										
	Cable, Mid, 120'/10", AGCO, Hawkeye 2	115-2005-164											2
	Cable, Outer, 120'/10", AGCO, Hawkeye 2	115-2005-165											2
	Cable, Mid, 120'/19", RoGator C, Hawkeye 2	115-2005-177						2					

Picture	Item Description	Part Number	Qty.										
			117-2005-										
			104	105	106	107	108	109	110	115	116	118	
	Cable, Outer, 120'/19", RoGator C, Hawkeye 2	115-2005-178							2				
	Cable, Mid, 100'/19", RoGator C, Hawkeye 2	115-2005-181								2			
	Cable, Outer, 100'/19", RoGator C, Hawkeye 2	115-2005-182								2			
	Cable, Mid, 120'/15", RoGator C, Hawkeye 2	115-2005-185									2		
	Cable, Outer, 120'/15", RoGator C, Hawkeye 2	115-2005-186									2		
	Cable, Mid, 100'/15", RoGator C, Hawkeye 2	115-2005-189										2	
	Cable, Outer, 100'/15", RoGator C, Hawkeye 2	115-2005190										2	
	Cable, Outer, 90'/20", Hawkeye 2	115-2005-205				2							
	Kit, Hawkeye 2 Hypro Service	117-2005-051	1	1	1	1	1	1	1	1	1	1	1
	Plate, RoGator C REM/ABM Mounting	107-0235-015	1	1	1	1	1	1	1	1	1	1	1
	Fuse, 70A Bolt Down MIDI/AMI	510-1003-048	1	1	1	1	1	1	1	1	1	1	1
	Nut, M5 Flange Nylon Lock	312-4000-215	2	2	2	2	2	2	2	2	2	2	2

Picture	Item Description	Part Number	Qty.										
			117-2005-										
			104	105	106	107	108	109	110	115	116	118	
	Nut, M8 Flange Nylon Lock	312-4000-217	1	1	1	1	1	1	1	1	1	1	1
	Bolt, M6-1, x 75mm (G8- Class II Coating)	311-4050- 147K	2	2	2	2	2	2	2	2	2	2	2
	Bolt, M6-1, x 65mm (G8- Class II Coating)	311-4050- 145K	1	1	1	1	1	1	1	1	1	1	1
	Bolt, M6-1, x 110mm (G8 - Class II Coating)	331-40050- 154K	1	1	1	1	1	1	1	1	1	1	1
	Bolt, M6-1 x 140mm (G8 - Class II Coating)	331-4050- 159K	2	2	2	2	2	2	2	2	2	2	2
	Nut, M6-1 Flanged Zinc Nyloc	312-4000-216	3	3	3	3	3	3	3	3	3	3	3
	Washer, M6 Zinc	313-1000-046	3	3	3	3	3	3	3	3	3	3	3
	Bolt, M6 x 1.0 x 75 Stainless Steel Hex	311-4058-147					12						
	U-Bolt, Zinc 4-1/16" W x 3" L x 3/8"-16 UNC	107-0171-852	2	2	2	2	2	2	2	2	2	2	2
	Nut, 3/8"-16 Zinc Flanged Lock	312-1001-164	4	4	4	4	4	4	4	4	4	4	4
	Cable, AGCO 132'/19" Inner Left Hawkeye® 2	115-2005-151					1	1					
	Cable, AGCO 132'/19" Inner Right Hawkeye® 2	115-2005-152					1	1					

Picture	Item Description	Part Number	Qty.											
			117-2005-											
			104	105	106	107	108	109	110	115	116	118		
	Cable, Inner, 132'/20", AGCO, Millenim Boom, Hawkeye 2	115-2005-159	2											
	Cable, Inner, 120'/20", AGCO, Hawkeye 2	115-2005-002		2										
	Cable, Inner, 100'/20", AGCO, Hawkeye 2	115-2005-123			2	2								
	Cable, Left Inner, 100'/19", RoGator C, Hawkeye 2	115-2005-179								1				
	Cable, Right Inner, 100'/19", RoGator C, Hawkeye 2	115-2005-180								1				
	Cable, Left Inner, 120'/15", RoGator C, Hawkeye 2	115-2005-183									1			
	Cable, Right Inner, 120'/15", RoGator C, Hawkeye 2	115-2005-184									1			
	Cable, Left Inner, 100'/15", RoGator C, Hawkeye 2	115-2005-187										1		
	Cable, Right Inner, 100'/15", RoGator C, Hawkeye 2	115-2005-188										1		
	Cable, Left Inner, 120'/10", RoGator C, Hawkeye 2	115-2005-162												1

Picture	Item Description	Part Number	Qty.										
			117-2005-										
			104	105	106	107	108	109	110	115	116	118	
	Cable, Left Inner, 120'/10", RoGator C, Hawkeye 2	115-2005-163											1
	Valve, Hypro Hawkeye® 2 Nozzle Control	063-2005-002	80	72	60	54	85	78	63	95	80	143	
	O-Ring, Size - 115 Blue Viton (38 Pack)	219-2005-115M	2	2	1	1	2	2	2	2	2	4	
	O-Ring, Size - 115 Blue Viton	219-2005-115	10		25	19	14	9		25	9		
	Nozzle Body, Hypro 5-Way Turret, AGCO, Left Port	333-0002-359	80	72	60	54	85	75	63	95	80	143	

TABLE 5. Hawkeye® 2 Service Kit Components for Wilger Nozzle Bodies (P/N 117-2005-052)



Picture	Item Description	Part Number	Quantity
	Nozzle Control Valve, Hawkeye® 2, Wilger	063-2005-003	1
Not Pictured	Kit, Individual Repair, Hawkeye® 2 NCV, Wilger	117-2005-062	3
Not Pictured	Cable, Hawkeye® 2 8-pin Ampseal Jumper	115-2005-070B	2
	O-Ring, Size -116 Black Viton (Single)	219-2005-116	1
	Tool, Hawkeye® 2 Universal	321-0000-490	2
	Relay, SPST Micro 12V N.O. 280 SRS	415-1001-020	2
	Fuse, Mini-Blade Type 15 Amp	510-1003-041	2

TABLE 6. Hawkeye® 2 Service Kit Components for Hypro Nozzle Bodies (P/N 117-2005-051)

Picture	Item Description	Part Number	Quantity
	Nozzle Control Valve, Hawkeye® 2, Hypro.	063-2005-002	1
Not Pictured	Kit, Individual Repair, Hawkeye® 2 NCV, Hypro/Arag	115-2005-061	3
Not Pictured	Cable, Hawkeye® 2 8-pin Ampseal Jumper	115-2005-070B	2
	O-Ring, Size -115 Purple (Single)	219-2005-115	1
	Tool, Hawkeye® 2 Universal	321-0000-490	2
	Relay, SPST Micro 12V N.O. 280 SRS	415-1001-020	2
	Fuse, Mini-Blade Type 15 Amp	510-1003-041	2

---

## UPDATES

Raven software and documentation updates may be made available periodically on the Raven Applied Technology web site:

[www.ravenprecision.com](http://www.ravenprecision.com)

At Raven Industries, we strive to make your experience with our products as rewarding as possible. One way to improve this experience is to provide us with feedback on this manual.

Your feedback will help shape the future of our product documentation and the overall service we provide. We appreciate the opportunity to see ourselves as our customers see us and are eager to gather ideas on how we have been helping or how we can do better.

To serve you best, please send an email with the following information to

[techwriting@ravenind.com](mailto:techwriting@ravenind.com)

-Hawkeye® 2 Installation Manual for AGCO RoGator C-Series (RG900, RG1100, RG1300)

-016-0171-712 Rev. B

-Any comments or feedback (include chapter or page numbers if applicable).

-Let us know how long have you been using this or other Raven products.

We will not share your email or any information you provide with anyone else. Your feedback is valued and extremely important to us.

Thank you for your time.





# CHAPTER

# INSTALLATION PREPARATION

## 3

Perform the following procedure to prepare for the Hawkeye® 2 system installation.

	<p><b>⚠ CAUTION</b></p> <p>Chemical residues may be present. Thoroughly bleed pressure from chemical lines and rinse the system with clean water prior to installing or servicing fittings, hoses, valves, or nozzles in the application system.</p>
-----------------------------------------------------------------------------------	------------------------------------------------------------------------------------------------------------------------------------------------------------------------------------------------------------------------------------------------------

1. Rinse and fill the tank with clean water.
2. Move the equipment to an open area suitable for testing the application system and rinsing the boom plumbing.
3. Unfold the boom and enable the application control system. Verify that all control hardware (e.g. control valves, section valves, etc.) and spray tips function as expected.
4. Operate the system until all chemicals are rinsed from the boom supply lines.
5. Disable the application control system and relieve boom pressure.
6. Replace existing carrier line strainer(s) with an 80 mesh (or finer) strainer. An 80 mesh (or finer) strainer is required for use with the Hawkeye® 2 nozzle control system.
7. Remove the spray tips from the boom and set aside for later use.

**NOTE:** If turret style nozzle bodies are installed on the implement, the turret may be rotated to an open spray position, if available. If an open spray position is not available, remove spray tips from a spray position and set aside for later use.

8. Enable the application control system and run clean water for at least 20 seconds to rinse any remaining debris from the boom plumbing and nozzle bodies.
9. Remove the cap and diaphragm from the nozzle bodies.

FIGURE 1. Nozzle Body Cap and Diaphragm Removed



Diaphragm Check Valve  
Removed



---

# CHAPTER

# 4

# NOZZLE BODY AND NOZZLE CONTROL VALVE INSTALLATION

---

## HAWKEYE® 2 NOZZLE BODY INSTALLATION

After completing the steps in Chapter 3, *Installation Preparation*, install the provided nozzle bodies and nozzle control valves.

### BEST PRACTICES AND RECOMMENDATIONS

- Do not connect battery leads until all cables are installed and connected.
- If a dual outlet nozzle body is installed on the boom, always mount the Hawkeye® 2 nozzle control valve to the closest port to the boom tube to avoid higher stress on the nozzle body.

### HYPRO NOZZLE BODY INSTALLATION

**NOTE:** For some Hypro kits, the standard Hypro nozzle bodies will need to be replaced with left-handed versions of the 5-way nozzle body in order to prevent interferences with the NCV2.

FIGURE 1. Valve Face O-Ring and Nozzle Control Valve Installed



Valve Body Face O-Ring  
(Place O-Ring Here)



Purple O-Ring



Nozzle Body

1. Locate included Hypro 5-way, left-handed nozzle bodies in the kit.

2. Remove existing Hypro 5-way, right-handed nozzle bodies from the sprayer by unscrewing the Phillips screw located in the clamp.
3. Install the left-handed nozzle bodies, replacing all right-handed nozzle bodies.

**NOTE:** Boom tube support brackets may need to be adjusted to provide clearance for left-handed nozzle bodies and NCV2s. If obstructions cannot be removed, a right-handed nozzle body may be reinstalled in that position, however the NCV2 may interfere with rotating the 5-way turret.

4. Replace any spray tips on the newly installed nozzle bodies as needed.

FIGURE 2. Hypro Left-Handed Nozzle Bodies Installed

---



## WILGER NOZZLE BODY ASSEMBLY & INSTALLATION

**NOTE:** For Wilger versions of the Hawkeye® 2 kit, the Wilger nozzle bodies require some assembly before installation onto the plumbing. The assemblies will vary with boom type and location on the sprayer.

There are two different types of Wilger nozzle bodies that will need to be assembled and installed. See Figure 3 on page 25.

If ProStop-E valves are to be used on the secondary outlet of the Wilger nozzle bodies, an adapter is included for the valve.

Wilger-to-Square lug tip adapters are also included to allow use with a wider variety of spray tips.

AGCO SPRAY BOOMS NOZZLE BODY ASSEMBLY

1. Locate the components provided to assemble the two configurations of the nozzle bodies.

FIGURE 3. Wilger Nozzle Body Configurations

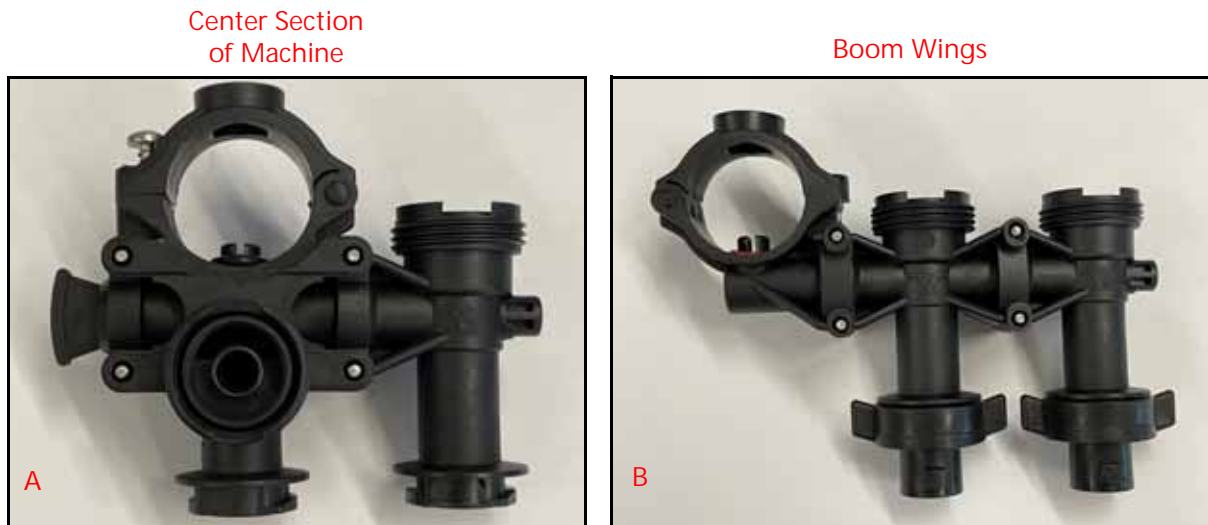

2. Remove the stainless steel U-clip provided with the nozzle bodies.
3. Align the nozzle body or plug as necessary and reinstall the U-clip to secure.
4. If the Wilger-to-Square lug tip adapters are needed to accommodate the tips to be used, install them on the outlets of the nozzle bodies by rotating them a quarter turn.

FIGURE 4. Outlets of the Nozzle Body

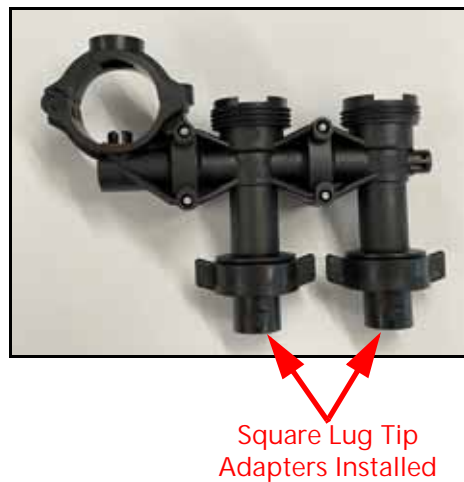

### AGCO NOZZLE BODIES INSTALLATION

**NOTE:** The Center Rack and first three locations on the primary boom to the left and right of the center rack will use the Saddle with Integrated Nozzle + End Body configuration. These locations do not have the structural boom tube running below the wet boom tube, thus it does not interfere with the spray pattern. Refer to image "A" in Figure 3 on page 25.

Every other location on the spray boom will use the Side Take-off Saddle + Thru Body + End Body configuration. These locations have the structural boom tube that runs directly below the wet boom tube, thus the nozzle outlets need to be offset behind this tube. Refer to image "B" in Figure 3 on page 25.

1. Remove the existing nozzle bodies on the spray boom, if necessary.
2. Install the Wilger nozzle bodies on the spray boom by aligning the inlet with the hole in the boom tube in each location.
3. Close the clamp and tighten the screw to secure.

### MILLENNIUM SPRAY BOOMS ASSEMBLY

**NOTE:** Millennium spray booms can accommodate the Wilger dual outlet with 5-way turret configuration in every location.

1. Locate the components provided to assemble the nozzle bodies.

FIGURE 5. Wilger Dual Outlet with 5-Way Turret Assemblies

---



2. Remove the stainless steel U-clip provided with the nozzle bodies.
3. Align the 5-way turret body or plug as necessary and reinstall the U-clip to secure, observing the "This Side Down" indicator on the 5-way turret.

4. If the Wilger-to-Square lug tip adapters are needed to accommodate the tips, install those on the outlets of the nozzle bodies by rotating them a quarter turn.

FIGURE 6. Wilger Nozzle Body Assembly with Tip Adapter Installed



Tip Adapter  
Installed

#### MILLENNIUM SPRAY BOOMS INSTALLATION

1. Remove the existing nozzle bodies from the spray boom if necessary.

NOTE: If ProStop-E valves are installed, please see the next section for removal and re-installation.

Leave all cables connected to the ProStop-E valves; they can be utilized and controlled by the Hawkeye® 2 system on the second outlet of the nozzle body.

2. Install the Wilger nozzle bodies with 5-way turrets on the spray boom by aligning the inlet with the hole in the boom tube at each location.
3. Close the clamp and tighten the screw to secure.

## INSTALL THE PROSTOP-E VALVE

**NOTE:** For the Wilger version of Hawkeye® 2 kits, the Hawkeye® 2 system will control the Hypro ProStop-E on/off valve in addition to the NCV. In order to accommodate both valves, a Wilger dual drop nozzle is installed along with an adapter for the ProStop-E.

1. Install the four O-rings into the ProStop-E adapter.

FIGURE 7. ProStop-E Adapter O-Ring Installation



2. Remove the ProStop-E valve from the original Hypro nozzle body by removing the U-clip that attaches it to the threaded nut. Pull on the valve to separate it from the nut, and spin the nut to remove it from the nozzle body.

**NOTE:** Leave the ProStop-E connected to the existing cabling.

3. Remove the Hypro Nozzle body from the boom tubing.
4. Thread the ProStop-E adapter (P/N 063-0173-964) onto the threaded port of the Wilger nozzle body furthest from the boom tube clamp.

FIGURE 8. ProStop-E Adapter Installation Location

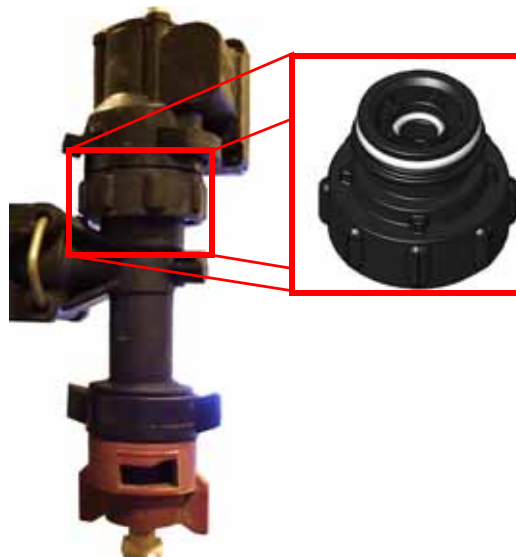



5. Attach the Wilger nozzle body to the boom.
6. Install the Hawkeye® 2 NCV to the Wilger nozzle body port closest to the wet boom tube.
7. Using the U-clip, install the ProStop-E to the previously installed adapter.

**IMPORTANT:** Ensure the flat surface on the U-clip is towards the ProStop-E body (tabs down). Failure to do so will result in leaks and potential damage to components.

### SPECIAL INSTALLATION INSTRUCTIONS

1. For the nozzle bodies on the center rack and the inner three locations of each primary boom segment, use the modified nozzle body assembly shown below. The assembly requires the Wilger nozzle body 2-way inlet (P/N 333-0002-332), the Wilger adapter plug (P/N 333-0002-319), and Wilger end body (P/N 333-0002-325).

FIGURE 9. Completed Wilger Assembly

---



### BUMPER INSTALLATION FOR C-SERIES MACHINES WITH PROSTOP-E VALVES AND WILGER NOZZLE BODIES

It is necessary to add spacers to the boom bump stops to help prevent nozzle bodies from colliding with each other upon folding, causing damage to the nozzle bodies. To install bump stop spacers:

1. Locate the boom stops shown in Figure 10, "Boom Stop," and remove the existing hardware. Keep the existing washers and nuts.

FIGURE 10. Boom Stop

---



2. Place two boom stop spacers (P/N 107-0172-609) behind the boom stop.

FIGURE 11. Installed Boom Spacers

---



3. Use the longer bolt provided in the kit (P/N 311-0070-014) and the original nuts and washers to secure the boom stop and spacers.

## NOZZLE CONTROL VALVE 2 (NCV2) INSTALLATION

1. Locate the Hawkeye® 2 NCVs and the O-rings provided with the kit.

NOTE: Hypro NCV2 and nozzle body will use the purple-colored (size 115) O-rings (P/N 219-2005-115)

Wilger NCV2 and nozzle body will use the black-colored (size 116) O-rings (P/N 219-2005-116)

2. Place the supplied O-ring on the inside of the fly nut flush with the valve body face.

FIGURE 12. Black and Purple O-Rings

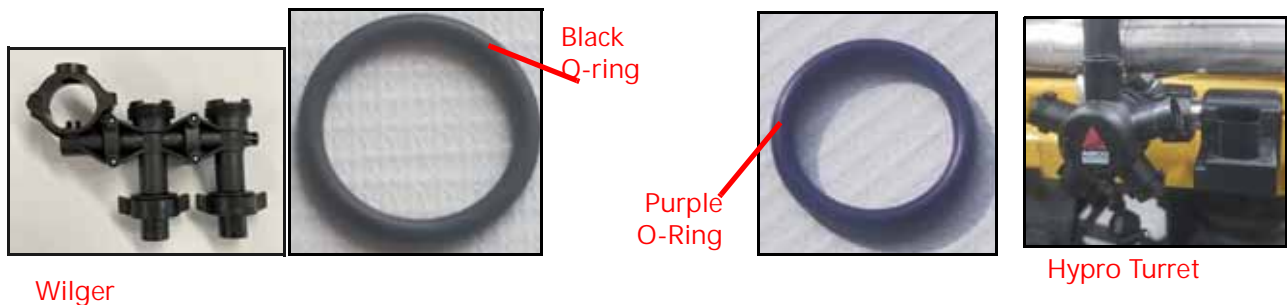

3. Remove the diaphragm check valve from the threaded port of each nozzle body as needed.
4. Align the NCV2 with the port of the nozzle body while being careful not to lose the O-ring.

NOTE: On Wilger nozzle bodies, the NCV2 should always be located on the port closest to the wet boom tube unless interferences do not allow this. This will create the least amount of stress on the nozzle body and should allow satisfactory cable routing.

5. Turn the fly nut of the NCV2 to engage the threads of the nozzle body. Tighten until the NCV2 no longer rotates freely.

NOTE: A leak test is recommended after the installation is complete.

## BOOM CABLE ROUTING AND CONNECTION

### BEST PRACTICES AND RECOMMENDATIONS

- Route the Hawkeye® 2 primary, mid, and outer boom cables along existing cables or plumbing to avoid cable damage.
- Route cables to avoid pinch points and to avoid stretching the cable during folding and unfolding operations. Pay special attention to cable routing near folding or break-away points.
- Route cables through existing cable retention devices as appropriate.
- When securing the primary, mid, and outer boom cables on the implement, begin at the outer boom tips. Adjust the cable position to provide sufficient slack between valve tee branches while working toward the center of the implement.
- Route the boom cables on the inside of the boom frame when possible.
- Secure cables using a zip tie at each nozzle control valve tee branch, and one between each tee branch along the cable length.

## BOOM CABLE ROUTING AND CONNECTIONS (INNER, MIDDLE, AND OUTER BOOM CABLES)

1. Locate the boom cables included with the Hawkeye® 2 installation kit. There are typically six boom cables for a single system:
  - 2 inner boom cables (may be left and right specific).
  - 2 mid boom cables.
  - 2 outer boom cables.
2. On the inner boom cable, locate the end of the cable with the rotating locking collar.
3. Start with the rotating locking collar side of the cable near the center of the center rack and route the cable going outwards towards the boom tip, following plumbing routing whenever possible.

**NOTE:** Keep the boom connections clean and off the ground while routing.

Do not secure cables with cable ties until all cables are in place and routings are checked for pinch points and other interferences.

Ensure sufficient slack is available at fold and break-away joints to allow for full range of motion without stretching the cable.

4. Next, repeat step 1 through 3 for the inner boom cable for the opposite side.
5. Continue routing both mid and outer boom cables, and repeat step 1 through 4 for both mid and outer boom cables.

**NOTE:** The connector with the rotating locking collar will always go towards the center of the machine.

6. If not already applied, apply a single, short burst of corrosion inhibitor. Corrosion X HD (P/N 222-0000-020 or available from <http://www.corrosionx.com/corrosionx-heavy-duty.html>) is recommended.
7. Be sure the corrosion inhibitor has coated the NCV contacts and recessed portions of the connector.

**NOTE:** To determine if corrosion inhibitor has been applied, inspect for a thick liquid in the bottom of the connector.

8. Once all boom cables are routed along the boom as desired, begin connecting the boom cables to the Hawkeye® 2 NCVs previously installed.
9. Use provided cable ties to secure the boom cables to the boom components as needed to ensure they are secure.

**NOTE:** Do not put strain on cables and connections while applying tie-downs.

Do not leave any exposed cable loops that may get caught on crops or other debris while the vehicle is in use.

10. The inner boom cables will be connected to the ECU cable in a later section.

# CHAPTER

# 5

# INSTALL THE HAWKEYE® 2 RCM - SPRAYER

## RCM - SPRAYER INSTALLATION

### BEST PRACTICES AND RECOMMENDATIONS

- Do not connect battery leads until all cables are installed and connected.
- If a protected mounting location is not available on the equipment, mount the RCM - Sprayer with the connectors facing down toward the ground to prevent moisture from accumulating in the RCM - Sprayer connections.

### RCM - SPRAYER MOUNTING LOCATION

1. Locate the foam marker pump (if applicable) and ECU cabinet between the axles on the right side of the machine.

FIGURE 1. RoGator 1300 ECU Cabinet and Foam Marker Pump Location

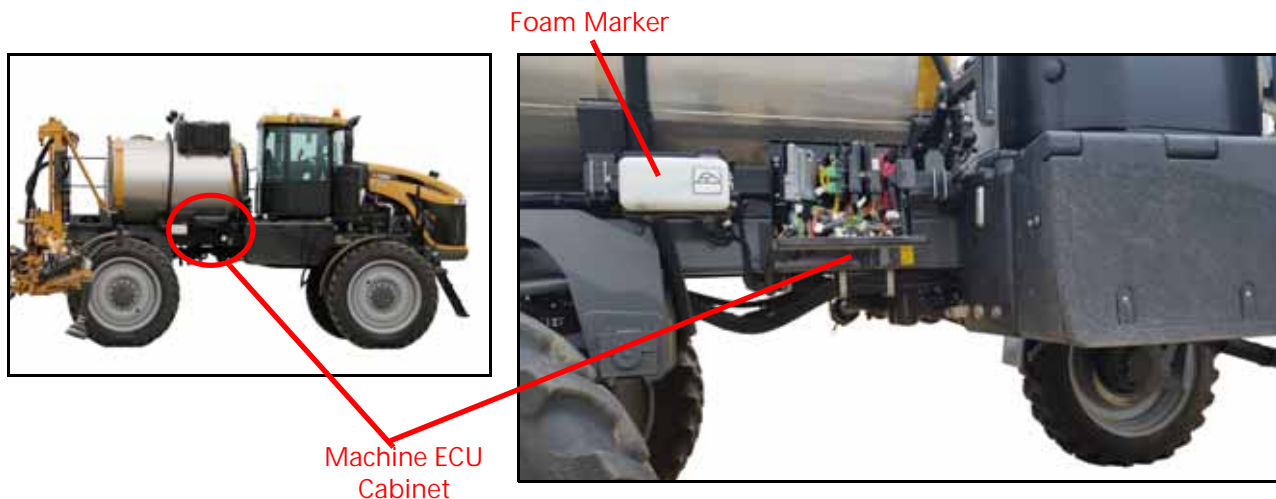

NOTE: If a foam marker is present on the machine, refer to the “RCM - Sprayer Mounting With Foam Marker” on page 34.

If Raven Autoboam XRT is already installed on this machine, refer to “RCM - Sprayer Mounting with Raven Autoboam XRT” on page 36.

2. Use the supplied u-bolts (P/N 107-0171-852) and 3/8” hardware to secure the RCM - Sprayer mounting plate (P/N 107-0235-015) to the outside of the frame structure, roughly 12” behind the ECU cabinet. Mount the plate so that the tabs at the bottom of the plate face toward the center of the machine.

- Secure the RCM - Sprayer (P/N 063-0173-956) to the plate using the supplied bolts (M6 x75mm (qty 2), M6 x 65mm (qty 1), and flanged nylon lock nuts (qty 3)). It is recommended to mount the RCM - Sprayer to the inside of the mounting plate.

FIGURE 2. RCM - Sprayer Mounted

---



#### RCM - SPRAYER MOUNTING WITH FOAM MARKER

- Remove the four bolts from the bottom of the foam marker mounting bracket and remove the foam marker.

FIGURE 3. Remove the Foam Marker

---



2. Remove the hardware holding the foam marker mounting bracket and slip the bracket off of the existing u-bolts.
3. Place the RCM - Sprayer mounting plate (P/N 107-0235-015) on the existing u-bolts with the tabs at the bottom of the bracket facing toward the center of the machine.
4. Replace the foam marker mounting bracket.
5. Replace the existing nuts to secure the plate and foam marker mounting bracket.

FIGURE 4. RCM - Sprayer Mounted



6. Secure the RCM - Sprayer (P/N 063-0173-956) to the plate using the supplied bolts (M6 x75mm (qty 2), M6 x 65mm (qty 1), and flanged nylon lock nuts (qty 3)). It is recommended to mount the RCM - Sprayer to the inside of the mounting plate.

FIGURE 5. RCM - Sprayer Mounted

---



#### RCM - SPRAYER MOUNTING WITH RAVEN AUTOBOOM XRT

If the Raven Autoboam XRT system is installed on this machine, the Autoboam XRT ECUs are mounted in this same location, so alternative RCM - Sprayer mounting steps are required:

1. Remove the hardware securing the Autoboam XRT REM to the mounting plate.
2. Place the RCM - Sprayer on the opposite side of the mounting plate from the REM, aligning with the mounting holes.

**NOTE:** Some drilling may be required depending on the revision of the mounting plate.

3. Use the provided M6 x 110mm (qty 1) and M6 x 140mm (qty 2) bolts, along with M6 washers and M6 flanged nylon lock nuts to pass through both ECUs and fasten them to the mounting plate, one ECU on each side of the plate.



## ECU CABINET PREPARATION

1. Locate the ECU Cabinet on the right side of the machine between the axles and remove the cover.

FIGURE 6. RoGator 1300 ECU Cabinet Location

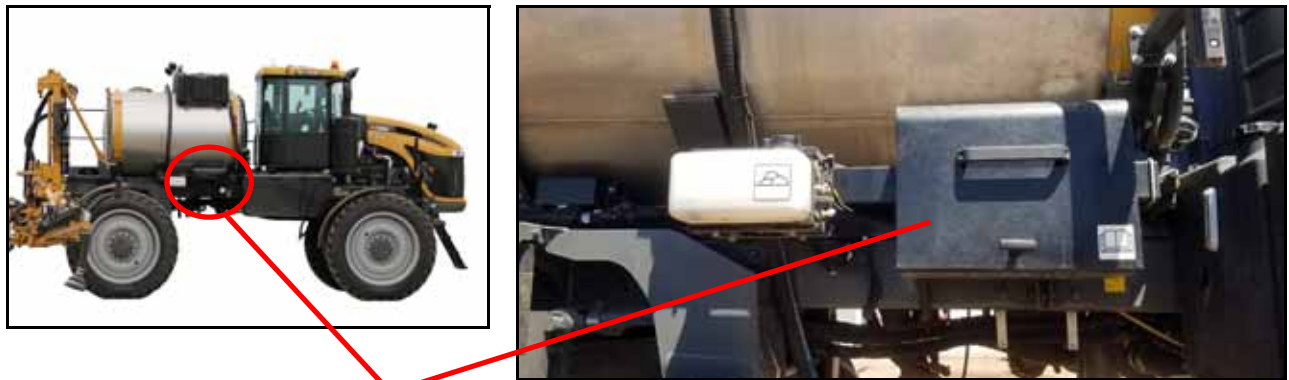

Machine ECU Cabinet

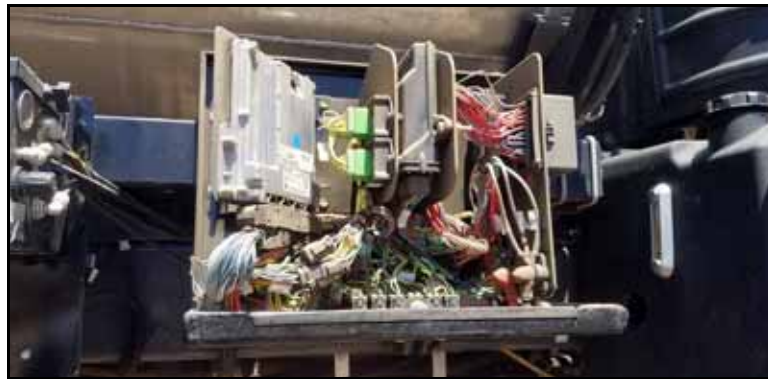

2. Locate the Raven ISO Product Control ECU.
3. Use a socket and socket extension to loosen the bolt securing the ECU mounting plate to the rear cabinet wall and remove the plate from the electrical box.

FIGURE 7. ECU Mounting Plate

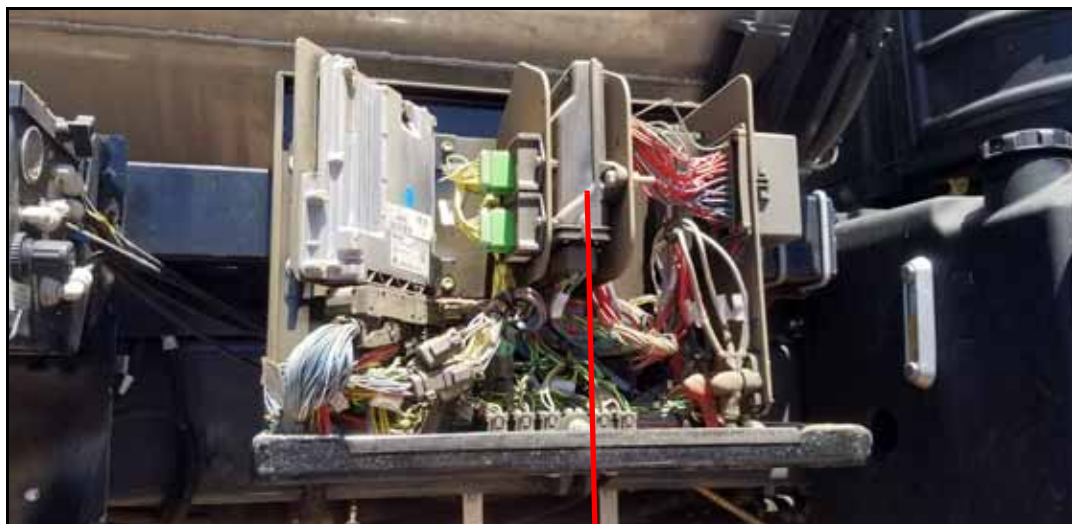

Raven ISO Product Controller ECU

4. Remove the bolts securing the Product Controller ECU to the mounting plate.
5. Disconnect the electrical connectors from the ECU by loosening the 1/4" hex screw of each connector, and set the ECU aside. The RCM - Sprayer will replace this device.
6. Reinstall the ECU mounting plate into the rear of the ECU cabinet using the original hardware.
7. Locate the X0778 connectors (RVN PWR) and X0780 (RVN SIGNALS) as shown in Figure 8, "Power and Signal Connections," and disconnect the ISO Product Controller Node jumper cable connections. The jumper cable may be removed with the ISO Product Controller ECU.

FIGURE 8. Power and Signal Connections

---



8. For signals to reach the X0780 connector, complete step a through step e.
  - a. Locate the Hawkeye® 2 bulkhead cable (P/N 115-2005-018) and connect the black 6-pin Deutsch plug into the mating connector labeled "Raven Node Power" in the ECU cabinet.
  - b. Connect the gray 12-pin Deutsch plug to the mating connector labeled "Raven Node Signals" in the ECU cabinet.
  - c. Remove the cap from the X0777 (RAVEN SIGNAL NODE).
  - d. Connect the X0775 (CNTRL SIGNAL) to X0777 (RAVEN NODE SIGNAL).
  - e. Place the cap on X0776 (EXT SIGNAL).

9. Remove the plug from one of the two locations circled in red in Figure 9, "Connecting RCM - Sprayer to ISOBUS (Drawing)," on the CANbus Hub in the base of the ECU cabinet.
10. Locate the connector X0150 labeled RVN CAN to RVN Node on the CANbus Hub and move it to the open connection where the plug was removed in the previous step. Replace the plug in this location. This will connect the RCM - Sprayer to the ISObus.

FIGURE 9. Connecting RCM - Sprayer to ISOBUS (Drawing)

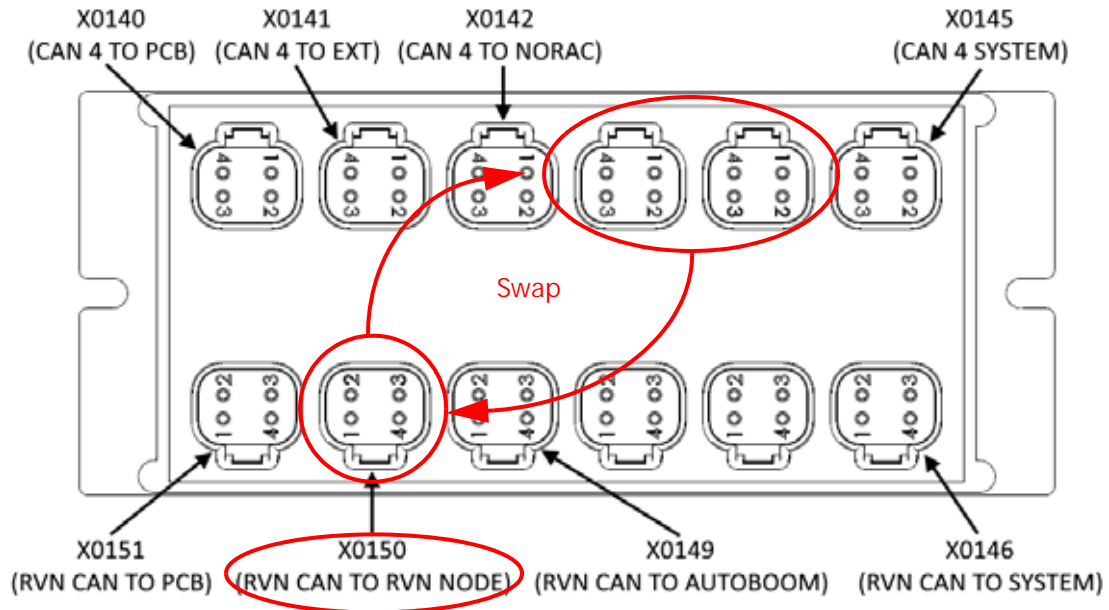
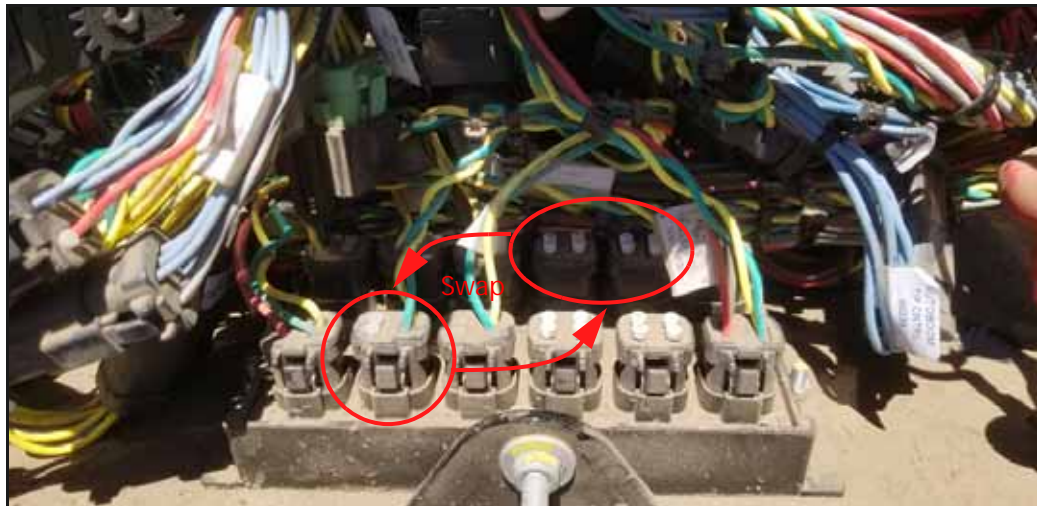

FIGURE 10. Connecting RCM - Sprayer to ISOBUS (Picture)



11. Remove the bolts securing the large ECU plate on the left side of the electrical box as shown in Figure 11, "Access to the Rear of the ECU Cabinet," and move the ECU to allow access to the back wall of the ECU Cabinet.

FIGURE 11. Access to the Rear of the ECU Cabinet

---

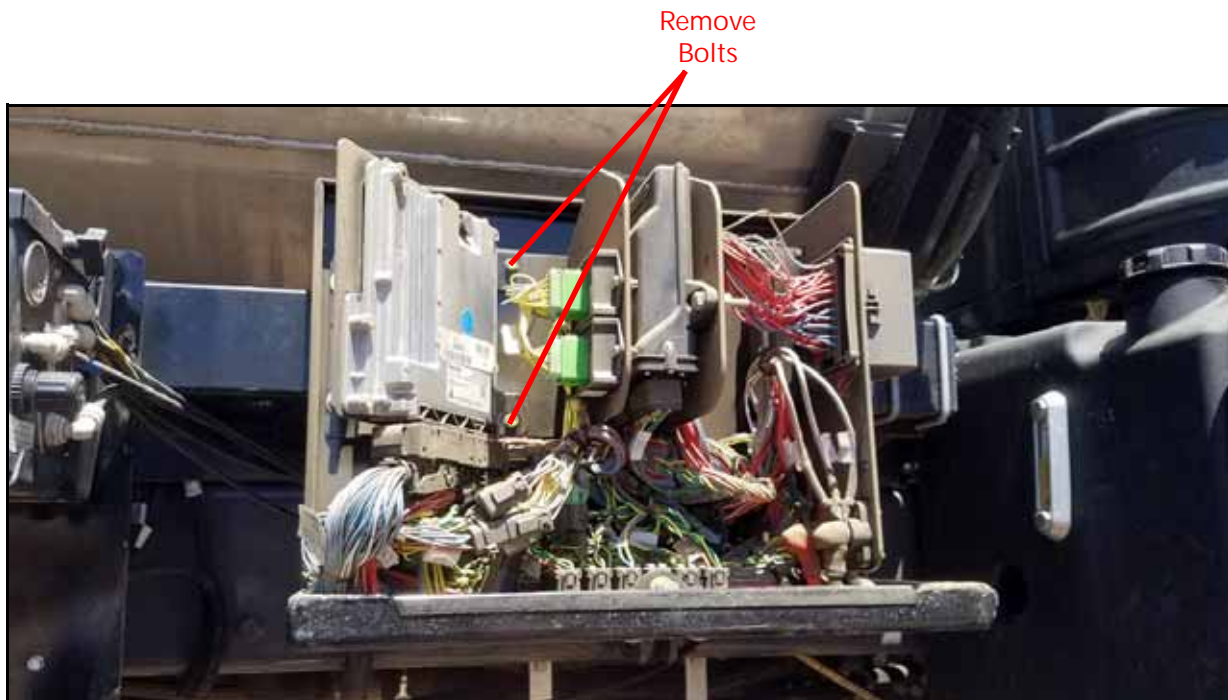

NOTE: Do not discard or modify the ECU or mounting plate.

12. Use a 1-1/2" hole saw to drill a hole through the back of the electrical box for the bulkhead connection of the Hawkeye® 2 bulkhead cable (P/N 115-2005-018) to pass through.

The recommended location for this port is toward the left edge of the box behind and below the ECU and bracket just removed about 1.0" below the bracket and 2.5" from the left edge of the ECU cabinet as shown in Figure 12 on page 41.

NOTE: Be careful not to damage any existing electrical components or wiring while drilling. This hole will be used later to connect the chassis cable to the electrical box cabling for final system connections.

FIGURE 12. ECU Cabinet Access for Hawkeye® 2

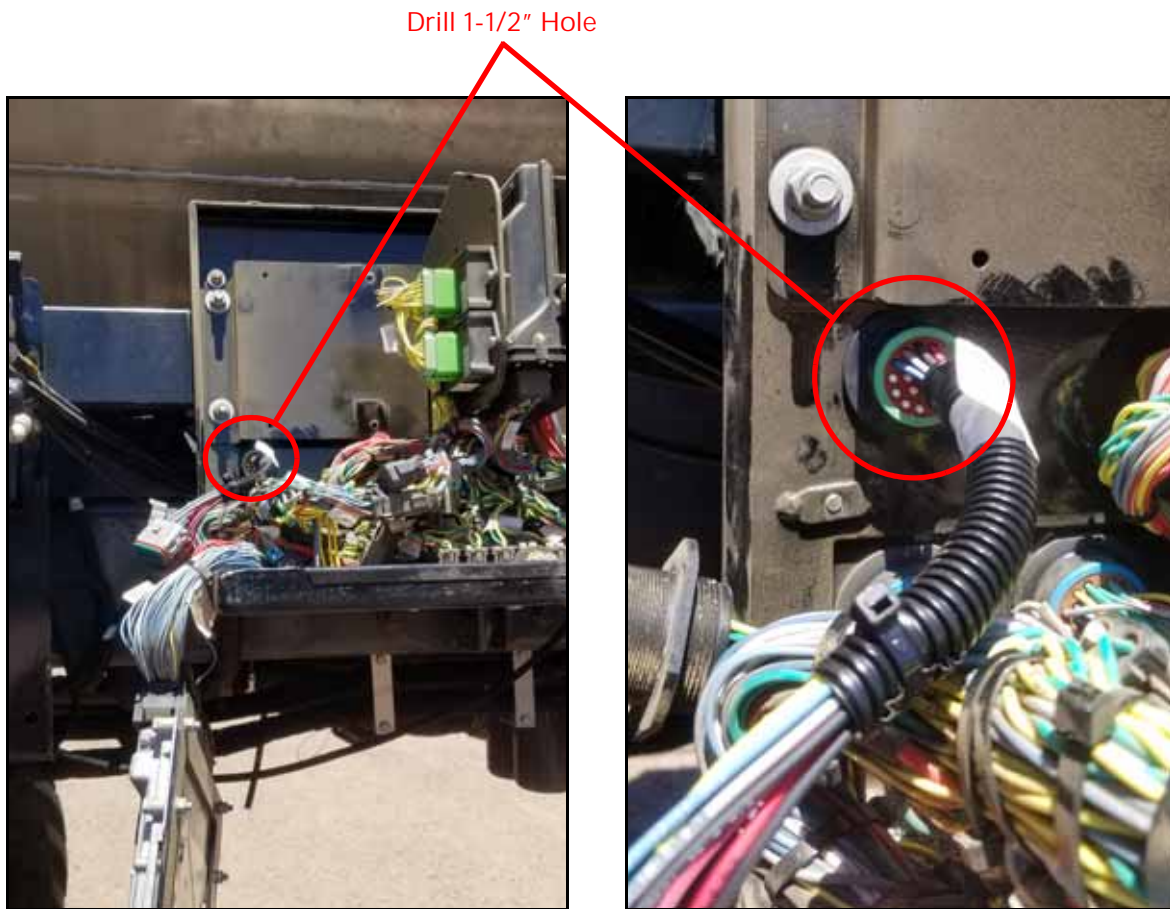

13. Remove the nut and washer from the round connector of the Hawkeye® 2 bulkhead cable.
14. Pass the round connector through the 1-1/2" hole drilled in the rear of the cabinet wall.
15. Reinstall the washer and nut hand tight from behind the ECU cabinet.
16. Replace the AGCO ECU and bracket removed previously using the original hardware.

## IN CAB CONNECTIONS

### VIPER 4 ISOBUS CONNECTION

1. Connect the two 2-pin Deutsch ISOBUS connectors located behind the Viper<sup>®</sup> 4 together.

FIGURE 13. ISOBUS Connections

---



## CHASSIS CABLE ROUTING AND CONNECTION

### BEST PRACTICES AND RECOMMENDATIONS

- Do not connect battery leads until all cables are installed and connected.
- Route chassis cabling along existing cabling or plumbing to help avoid pinch points or stretching the cable during normal equipment operation.

### ECU CABINET TO RCM - SPRAYER CONNECTIONS

1. Locate the single, round connector on the RCM - Sprayer cable (P/N 115-2005-019) provided in the kit.
2. Route this connector to the outside back wall of the ECU Cabinet and connect to the bulkhead connector of the Hawkeye® 2 bulkhead cable installed previously. Align the connector keyways and rotate the locking collar to secure.
3. Route the RCM - Sprayer cable (P/N 115-2005-019) back along the frame rail towards the RCM - Sprayer installed previously.
4. Connect the gray and black rectangular plugs to their mating connections of the RCM - Sprayer.
5. Secure the cable with the cable ties provided.

FIGURE 1. Chassis Cable ECU Cabinet Connection

---



## HAWKEYE® 2 ECU NCV POWER CABLE INSTALLATION

1. Locate the Hawkeye® 2 NCV Power cable (P/N 115-2005-017) provided in the kit.
2. Connect the black rectangular AmpSeal connector to the center port of the RCM - Sprayer installed previously.
3. Route the round connectors labeled “left boom” and “right boom” along the right frame rail towards the rear of the machine.
4. At the rear of the applicator tank, route the chassis cable underneath the rear catwalk and then up and over the center rack framework. Follow the supply lines to ensure adequate slack for operating the center rack during field operations and when folding and unfolding the booms.

FIGURE 2. NCV Power Cable Center Rack Routing

---

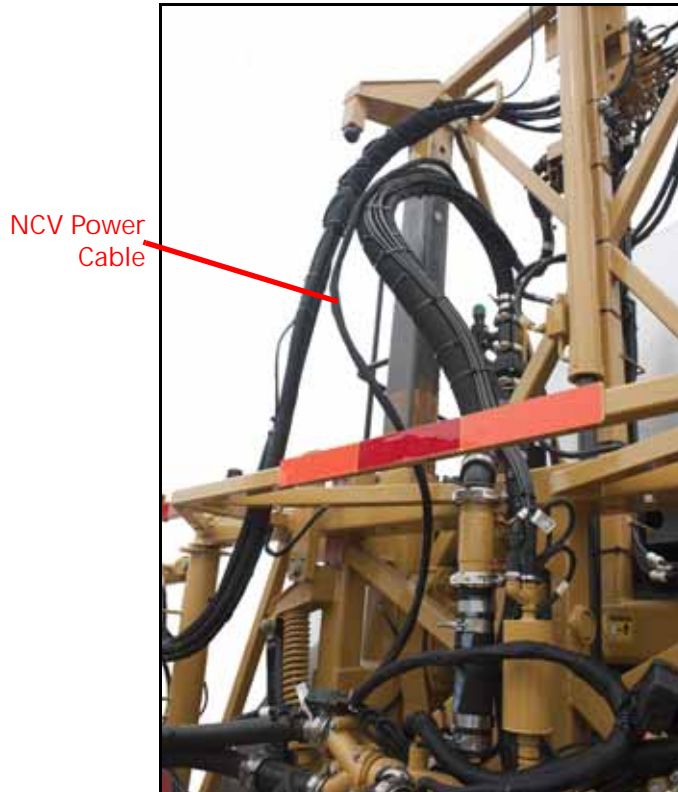

5. Use zip ties to secure the NCV Power cable to existing system lines to keep the cable from being damaged during normal equipment operation.
6. Connect the NCV power cable to the left and right boom cable connectors at the center rack.
7. Use supplied zip ties to secure any excess cabling on the center rack framework.
8. When installation is complete, re-connect the positive NCV power ring terminal before operating the equipment.



## HAWKEYE® 2 POWER CONNECTIONS (NO INJECTION)

1. Locate the three way fuse panel under the right-rear of the catwalk.
2. Place an 70 Amp AMI fuse (P/N 510-1003-048) in one of the two rear positions of the fuse panel.

FIGURE 3. Hawkeye® 2 Power Connection (No Injection)

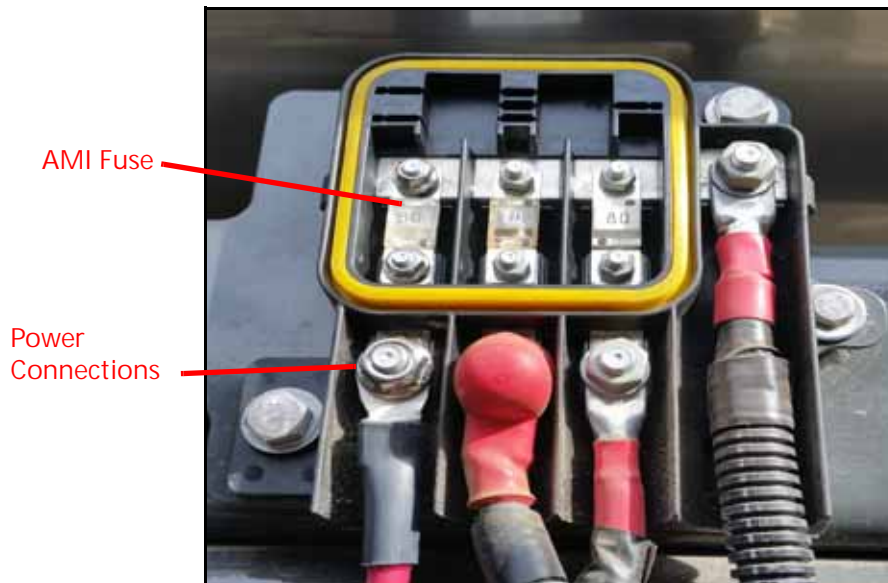

**NOTE:** If the system will include Sidekick Pro™ ICD injection, a secondary fuse panel is required. The injection pumps and Hawkeye® 2 will be powered via the secondary fuse panel. Refer to “Sidekick Pro™ ICD Installation” section on page 49 for additional information.

3. Connect one the M8 x 1.25 output studs to the power supply.
4. Route the ground wire along the frame rail and then behind the cab, across to the right side of the sprayer.
5. Remove the battery box cover on the catwalk floor, outside of the cab door.
6. Route the ground wire into the battery box and connect to the ground lug of the battery.
7. Replace the battery box cover and secure the ground cable with zip ties.

## SYSTEM DIAGRAMS

Diagrams start on the next page.

FIGURE 4. System Diagram (Page 1)

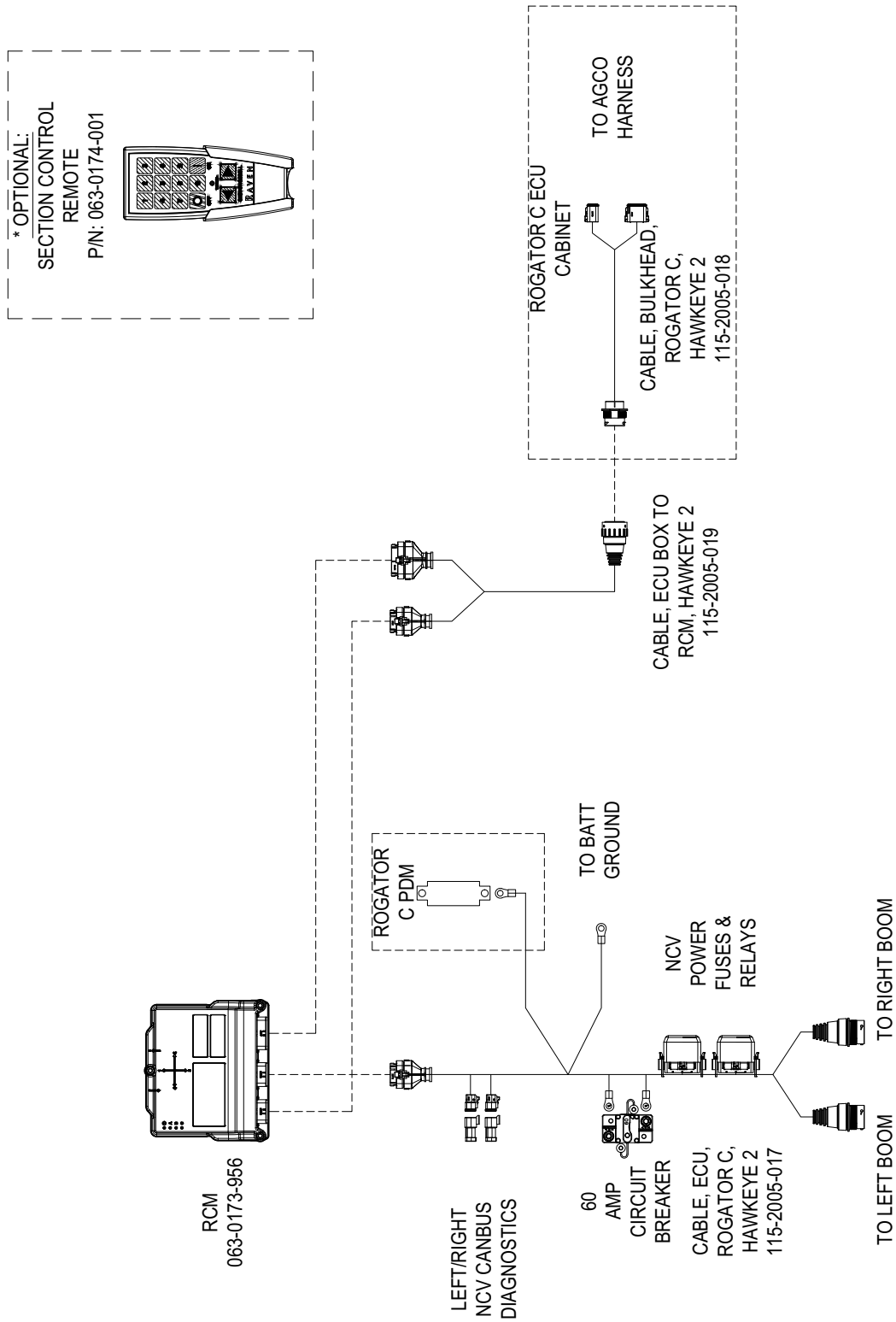
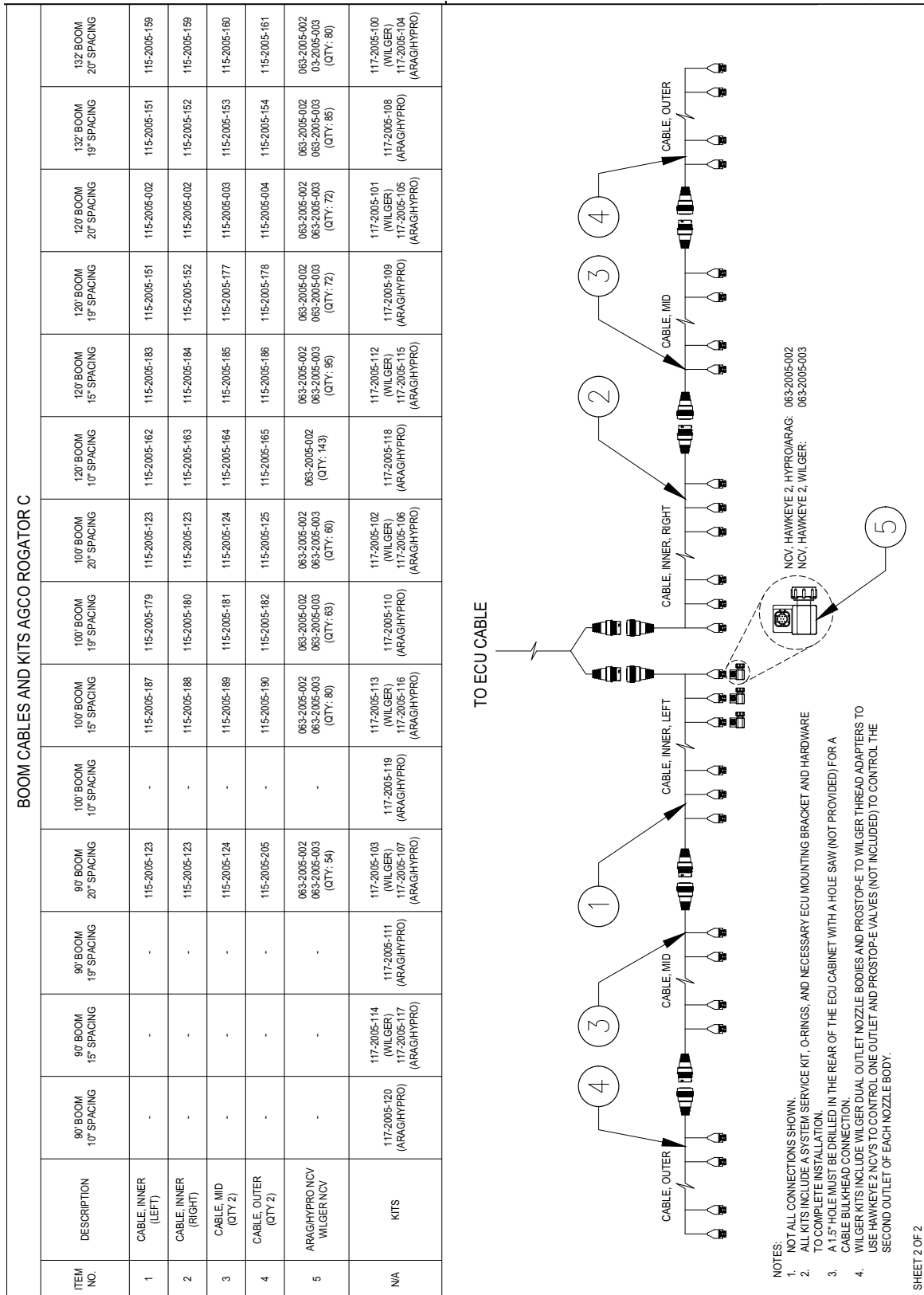

FIGURE 5. System Diagram (Page 2)





## SIDEKICK PRO ICD CONNECTIONS TO CANBUS HUB

Connecting the Sidekick Pro™ ICD pump to the Hawkeye® 2 system is done via CANbus Hub located behind the node enclosure on the right-hand side of the machine.

For machines that do not already have injection pumps, Raven cables P/N 115-0172-443 and P/N 115-0172-444 are required. For systems that have Raven CAN Sidekick™ Pro pumps installed, simply follow the instructions below. For systems with AGCONTROL, Sidekick Pro™ ICD pumps are installed and cables are connected.

1. Locate the CANbus Hub located on the above the axle on right-hand side of the machine.

FIGURE 1. Rear CANbus Hub Location

---



2. Remove the cover plate.
3. On the CANbus Hub, connect the "CAN 4 to BOOM" connector on AGCO harness 596775D1 into the second receptacle in the top row. Refer to Figure 2 on page 50.

FIGURE 2. PCB Connections

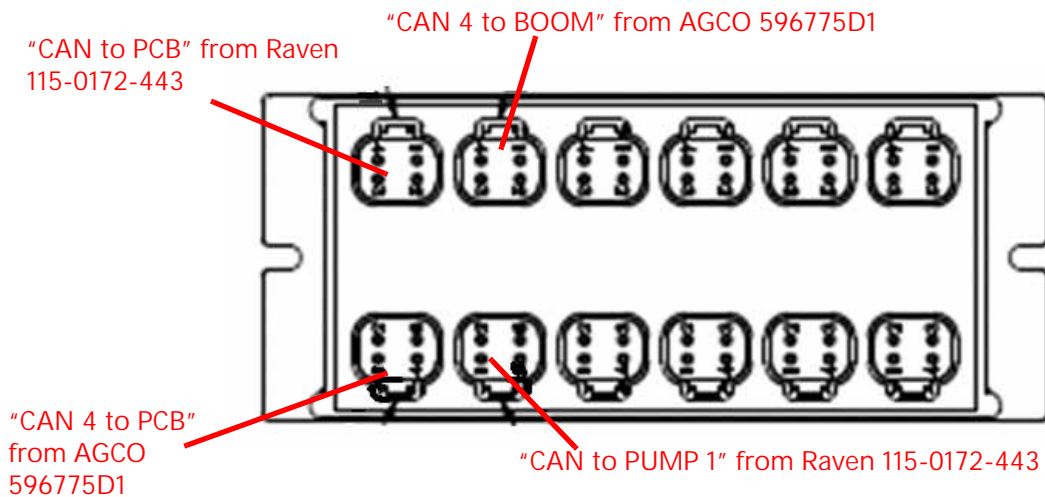

4. On the CANbus Hub, connect the "CAN 4 to PCB" connector from AGCO harness 596775D1 into the first receptacle in the bottom row. Refer to Figure 2 on page 50.
5. Connect the "CAN to PUMP1" connector from the Raven harness (P/N 115-0172-443) into the second port in the bottom row.
6. Unplug the terminator from the "CAN to PCB" connector on AGCO harness 596775D1. Set terminator aside for later use.
7. Insert "CAN to PCB" from the Raven harness (P/N 115-0172-443) into the first port on the top row.
8. Locate the connector labeled "INJECTION LOGIC" from the AGCO harness 596775D1. Connect the "INJECTION LOGIC" plug from 596775D1 to the "INJECTION LOGIC TO PUMP 1" receptacle on the Raven Harness (P/N 115-0172-443).
9. Locate the 4-pin terminator that was removed from the "CAN to PCB" connector. Plug the "RVN CAN to PCB" from AGCO harness 596775D1 into the terminator.

**NOTE:** Connections shown in picture below are based on a Raven CAN Sidekick Pro™ installed on the system.

## SIDEKICK PRO ICD CABLE TO PUMP CONNECTIONS

1. Route cable P/N 115-0172-443 along the frame rail and below the rear catwalk and up along the cables and hoses at the rear/center of the machine to the injection pumps.
2. Use cable P/N 115-0172-444 to connect to the first injection pump.
3. Connect the cable connections from Pump 1 to the P/N 115-0172-443 extension cable.
  - Connect the "INJECTION LOGIC" plug on the P/N 115-0172-443 extension to the 2-pin Deutsch connector on the P/N 115-0172-444 cable.
  - Connect "PUMP 1" from the P/N 115-0172-443 cable to the "CAN to PUMP" receptacle on the 115-0172-444 cable.
  - Connect "CAN to PCB" on the P/N 115-0172-443 cable to the "CAN to PUMP X or PCB" receptacle.
  - If a second pump is on the system, connect "CAN to PUMP X" to "CAN to PUMP" on the P/N 115-0172-444 cable for pump 2.
  - Remove the cap on the second 2-pin Deutsch connector and connect it to the P/N 115-0174-444 cable for pump 2.

---

## SIDEKICK PRO ICD POWER SUPPLY

When adding Sidekick Pro™ ICD injection to the machine with Hawkeye® 2, a second fuse panel must be installed to accommodate the power needs.

1. Install a four way fuse pane (P/N 510-2001-068) towards the rear of the machine near the injection pumps.

FIGURE 3. Four-Way Panel

---



2. Connect one end of cable P/N 115-0172-446 to the open stud on the front fuse panel located rearward of the main electrical enclosure and route to the four-way fuse panel.
3. Use extra hardware from the four-way panel to install the 125 Amp fuse (P/N 510-1003-049) to the same port on the three-way fuse panel.
4. Connect the other end of cable P/N 115-0172-446 to the center stud of the four-way panel.
5. Connect the positive ring terminal of the Hawkeye® 2 chassis cable (P/N 115-7303-310) to the port with the 70 Amp fuse on the four way panel.
6. Connect the positive ring terminal of the Sidekick Pro™ ICD cable (P/N 115-0172-444) to the port with the 30 Amp fuse on the four-way panel.
7. Repeat step 5 for additional pumps.
8. Connect the negative ring terminal from all cables to the ground stud located under the rear catwalk.
9. Secure all ring terminals with a retaining nut.





---

## APPENDIX

# CABLE AND CONNECTOR MAINTENANCE

## A

---

### POWER AND ECU HARNESS MAINTENANCE

1. Disconnect the ECU harness connector and inspect for signs of moisture or corrosion.
2. If moisture or corrosion is detected, use Deoxit D5, brushes, and compressed air to clean and dry the connector.
3. When clean, apply a coating of Corrosion X HD to the connector mating surfaces and contacts.
4. Reattach the connectors.

### HAWKEYE® 2 BOOM HARNESS CONNECTOR MAINTENANCE

Prior to connecting the boom cable to the Hawkeye® 2 Nozzle Control Valves (NCV), perform the following steps to all 6-pin NCV connectors and 19-pin circular connectors between the boom cables and ECU cable connections to ensure high quality connections:

1. Verify the NCV connectors and the accompanying boom cable connectors are free of moisture, contamination, or oxidation. Oxidation will appear as a dry, white coating on the contacts.  
If any connectors show signs of moisture, contamination, or oxidation, perform step 2 through step 6. If this is a new installation, skip to step 7. All components listed below can be ordered in the Hawkeye® 2 NCV Connection Maintenance Kit (P/N 117-0171-692).
2. Spray the connection with a deoxidizing agent.

NOTE: DeoxIT D5 (P/N 222-4001-006) is recommended.

FIGURE 1. DeoxIT D5 Applied to Hawkeye® 2 NCV



3. Clean contacts with a small wire brush (P/N 321-0000-477).

FIGURE 2. Cleaning Contacts with a Wire Brush

---



4. Spray the contacts again with the deoxidizing agent to help rinse out debris.
5. Remove residue of the deoxidizing agent from the connection.

	<p style="text-align: center;"><b>CAUTION</b></p> <p>Damage to the connector seal may occur if residue is not removed from the connector.</p>
-------------------------------------------------------------------------------------	-----------------------------------------------------------------------------------------------------------------------------------------------

6. Dry out the connection with dry, compressed air such as Dust Off Electronics Duster (P/N 222-4001-007) or equivalent air duster suitable for electronic components.

NOTE: If using compressed air from a large volume air compressor, be sure the lines are free of moisture.

FIGURE 3. Electronics Duster Used on NCV

---



- 
7. If not already applied, apply a single, short burst of corrosion inhibitor such as CorrosionX HD (P/N 222-0000-020) to the NCV2 connection. Be sure the corrosion inhibitor has coated the NCV2 contacts and recessed portions of the connector.

NOTE: To determine whether corrosion inhibitor has been applied, inspect for a thick liquid in the bottom of the connector as shown in the image below.

CorrosionX may also be purchased from the manufacturer website:

<https://www.corrosionx.com/products/corrosionx-heavy-duty>.

FIGURE 4. Applying Corrosion Inhibitor

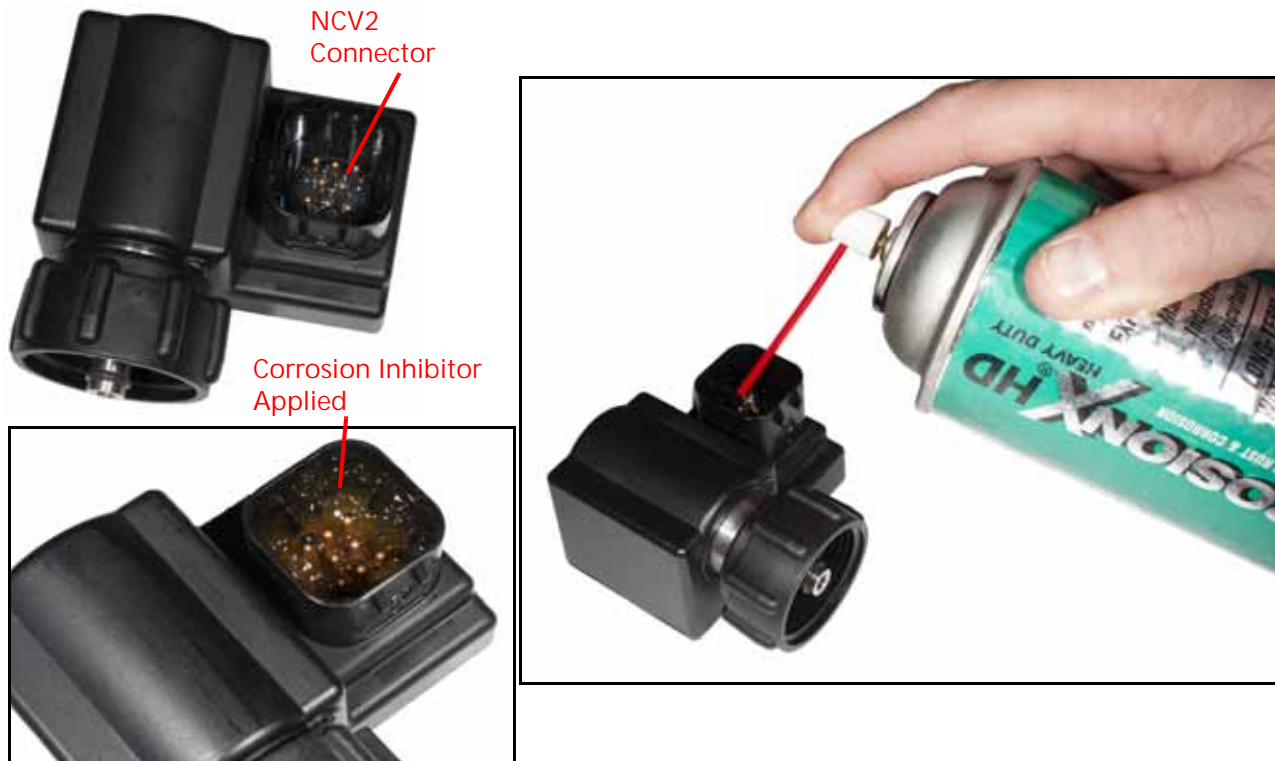



---

# APPENDIX

## B

# SPECIAL CONFIGURATION FOR PROSTOP-E COMBINATION KITS

---

### SECTION WIDTHS

When configuring the system, the correct section widths must be entered for proper control of the ProStop-E values. The table below displays the section widths for boom configuration.

TABLE 1. C-Series Section Widths

Section Number	120' x 15"	120' x 20"	100' x 15"	100' x 20"	90' x 15"	90' x 20"
1	60"	60"	45"	40"	15"	20"
2	90"	80"	60"	60"	30"	20"
3	90"	80"	60"	60"	60"	20"
4	90"	120"	60"	80"	60"	30"
5	60"	80"	90"	60"	90"	30"
6	135"	120"	90"	120"	90"	60"
7	135"	120"	135"	120"	135"	60"
8	105"	60"	105"	60"	105"	30"
9	135"	60"	135"	60"	135"	30"
10	135"	120"	90"	120"	90"	60"
11	60"	120"	90"	120"	90"	60"
12	90"	80"	60"	60"	60"	30"
13	90"	120"	60"	80"	60"	30"
14	90"	80"	30"	60"	30"	20"
15	60"	80"	45"	60"	15"	20"
16		60"		40"		20"

## SWITCH MAPPING

The AGCO system recognizes when Hawkeye® 2 is installed so switch mapping occurs automatically in the background. Do not adjust the default mapping of switches.

FIGURE 1. Default Switch Mapping Example



# LIMITED WARRANTY

## WHAT DOES THIS WARRANTY COVER?

This warranty covers all defects in workmanship or materials in your Raven Applied Technology Division product under normal use, maintenance, and service when used for intended purpose.

## HOW LONG IS THE COVERAGE PERIOD?

Raven Applied Technology products are covered by this warranty for 12 months from the date of retail sale. In no case will the Limited Warranty period exceed 24 months from the date the product was issued by Raven Industries Applied Technology Division. This warranty coverage applies only to the original owner and is non-transferable.

## HOW CAN I GET SERVICE?

Bring the defective part and proof of purchase to your Raven dealer. If the dealer approves the warranty claim, the dealer will process the claim and send it to Raven Industries for final approval. The freight cost to Raven Industries will be the customer's responsibility. The Return Materials Authorization (RMA) number must appear on the box and all documentation (including proof of purchase) must be included inside the box to be sent to Raven Industries.

## WHAT WILL RAVEN INDUSTRIES DO?

Upon confirmation of the warranty claim, Raven Industries will (at our discretion) repair or replace the defective product and pay for the standard return freight, regardless of the inbound shipping method. Expedited freight is available at the customer's expense.

## WHAT IS NOT COVERED BY THIS WARRANTY?

Raven Industries will not assume any expense or liability for repairs made outside our facilities without written consent. Raven Industries is not responsible for damage to any associated equipment or products and will not be liable for loss of profit, labor, or other damages. The obligation of this warranty is in lieu of all other warranties, expressed or implied, and no person or organization is authorized to assume any liability for Raven Industries.

**Damages caused by normal wear and tear, misuse, abuse, neglect, accident, or improper installation and maintenance are not covered by this warranty.**

# EXTENDED WARRANTY

## WHAT DOES THIS WARRANTY COVER?

This warranty covers all defects in workmanship or materials in your Raven Applied Technology Division product under normal use, maintenance, and service when used for intended purpose.

## DO I NEED TO REGISTER MY PRODUCT TO QUALIFY FOR THE EXTENDED WARRANTY?

Yes. Products/systems must be registered within 30 days of retail sale to receive coverage under the Extended Warranty. If the component does not have a serial tag, the kit it came in must be registered instead.

## WHERE CAN I REGISTER MY PRODUCT FOR THE EXTENDED WARRANTY?

To register, go online to [www.ravenhelp.com](http://www.ravenhelp.com) and select Product Registration.

## HOW LONG IS THE EXTENDED WARRANTY COVERAGE PERIOD?

Raven Applied Technology products that have been registered online are covered for an additional 12 months beyond the Limited Warranty for a total coverage period of 24 months from the date of retail sale. In no case will the Extended Warranty period exceed 36 months from the date the product was issued by Raven Industries Applied Technology division. This Extended Warranty coverage applies only to the original owner and is non-transferable.

## HOW CAN I GET SERVICE?

Bring the defective part and proof of purchase to your Raven dealer. If the dealer approves the warranty claim, the dealer will process the claim and send it to Raven Industries for final approval. The freight cost to Raven Industries will be the customer's responsibility. The Return Materials Authorization (RMA) number must appear on the box and all documentation (including proof of purchase) must be included inside the box to be sent to Raven Industries. In addition, the words "Extended Warranty" must appear on the box and all documentation if the failure is between 12 and 24 months from the retail sale.

## WHAT WILL RAVEN INDUSTRIES DO?

Upon confirmation of the product's registration for the Extended Warranty and the claim itself, Raven Industries will (at our discretion) repair or replace the defective product and pay for the standard return freight, regardless of the inbound shipping method. Expedited freight is available at the customer's expense.

## WHAT IS NOT COVERED BY THE EXTENDED WARRANTY?

Raven Industries will not assume any expense or liability for repairs made outside our facilities without written consent. Raven Industries is not responsible for damage to any associated equipment or products and will not be liable for loss of profit, labor, or other damages. Cables, hoses, software enhancements, and remanufactured items are not covered by this Extended Warranty. The obligation of this warranty is in lieu of all other warranties, expressed or implied, and no person or organization is authorized to assume any liability for Raven Industries.

**Damages caused by normal wear and tear, misuse, abuse, neglect, accident, or improper installation and maintenance are not covered by this warranty.**