

RCM ARAG Installation Manual with Manual Guidance

016-7100-002 Rev. A

11/2020

E36341



DISCLAIMER

While every effort has been made to ensure the accuracy of this document, Raven Industries assumes no responsibility for omissions and errors. Nor is any liability assumed for damages resulting from the use of information contained herein.

Raven Industries shall not be responsible or liable for incidental or consequential damages or a loss of anticipated benefits or profits, work stoppage or loss, or impairment of data arising out of the use, or inability to use, this system or any of its components. Raven Industries shall not be held responsible for any modifications or repairs made outside our facilities, nor damages resulting from inadequate maintenance of this system.

As with all wireless and satellite signals, several factors may affect the availability and accuracy of wireless and satellite navigation and correction services (e.g. GPS, GNSS, SBAS, etc.). Therefore, Raven Industries cannot guarantee the accuracy, integrity, continuity, or availability of these services and cannot guarantee the ability to use Raven systems, or products used as components of systems, which rely upon the reception of these signals or availability of these services. Raven Industries accepts no responsibility for the use of any of these signals or services for other than the stated purpose.

Chapter 1	Important Information.....	1
Safety		1
Displays and Control Consoles		1
Electrical safety		2
Touch Screen		2
Recommendations and Best Practices		2
Harness Routing		2
Chapter 2	Introduction.....	5
Installation Best Practices		5
Recommendations		5
Point of Reference		5
Kit Components		6
Updates		8
Chapter 3	Installation	9
Install 500S and 700S		9
Install CR7		10
Install the RCM		11
Best Mounting Practices		11
Route and Connect the Cables		11
System Drawings		14

SAFETY

NOTICE

Follow the operation and safety instructions included with the implement and/or controller and read this manual carefully before installing or operating this Raven system.

- Follow all safety information presented within this manual. Review implement operation with your local dealer.
- Contact a local Raven dealer for assistance with any portion of the installation, service, or operation of Raven equipment.
- Follow all safety labels affixed to system components. Be sure to keep safety labels in good condition and replace any missing or damaged labels. Contact a local Raven dealer to obtain replacements for safety labels.

Observe the following safety measures when operating the implement after installing this Raven system:

- Do not operate this Raven system or any agricultural equipment while under the influence of alcohol or an illegal substance.
- Be alert and aware of surroundings and remain in the operator seat at all times when operating this Raven system.
 - Do not operate the implement on any public road with this Raven system enabled.
 - Disable this Raven system before exiting the operator seat.
 - Determine and remain a safe working distance from obstacles and bystanders. The operator is responsible for disabling the system when a safe working distance has diminished.
 - Disable this Raven system prior to starting any maintenance work on the implement or components of this Raven system.
- Do not attempt to modify or lengthen any of the system control cables. Extension cables are available from a local Raven dealer.

DISPLAYS AND CONTROL CONSOLES

- If the display will not be used for an extended period, it is best to remove the display from the machine and store it in a climate controlled environment. This may help to extend the service life of electronic components.
- To prevent theft, secure the display and GPS antenna when leaving the machine unattended.

CAUTION

ELECTRICAL SAFETY

- Always verify that power leads are connected to the correct polarity as marked. Reversing the power leads could cause severe damage to the Raven system or other components.
- To prevent personal injury or fire, replace defective or blown fuses with only fuses of the same type and amperage.
- Do not connect the power leads to the battery until all system components are mounted and all electrical connections are completed.
- Always start the machine before initializing this Raven system to prevent power surges or peak voltage.
- To avoid tripping and entanglement hazards, route cables and harnesses away from walkways, steps, grab bars, and other areas used by the operator or service personnel when operating or servicing the equipment.

TOUCH SCREEN

- Only touch the touch-screen with your finger or by using a special touch-screen stylus/pen. Operating the touch-screen with sharp objects may cause permanent damage to the screen.
- Only clean the screen using a damp cloth. Never use caustic or other aggressive substances.

RECOMMENDATIONS AND BEST PRACTICES

HARNESS ROUTING

The word “harness” is used to describe any electrical cables and leads, both bundled and unbundled. Use the following guidelines and recommendations when connecting and routing harnesses while installing or maintaining this Raven system:

- Leave protective caps/covers over harness connectors until needed to avoid dirt and moisture from contaminating electrical circuits.
- Secure the harness to the frame or solid structural members at least every 12 in [30 cm].
- Follow existing harness runs already routed on the implement as much as possible. Proper harness routing should:
 - Secure harnessing and prevent the harness from hanging below the implement.
 - Provide sufficient clearance from moving components and operational zones around shafts; universal joints and suspension components; pulleys, gears, belts, and chains; moving linkages, cylinders, articulation joints, etc.
 - Protect harnessing from field debris and surrounding hazards (e.g. tree limbs, fence posts, crop stubble, dirt clumps or rocks that may fall or be thrown by the implement).
 - Protect harnessing from sharp bends, twisting, or flexing over short distances and normal implement operation.
 - Connectors and splices should not be located at bending points or in harness sections that move.
 - Ensure sufficient length for free movement of the implement during normal operation and prevent pulling, pinching, catching, or rubbing, especially in articulation and pivot points. Clamp harnessing securely to force controlled movement of the harness.

- Avoid abrasive surfaces and sharp edges such as sheared or flame cut corners, fastener threads or cap screw heads, hose clamp ends, etc.
- Do not connect, affix, or allow harnessing to come into contact with components with high vibration forces, hot surfaces, or components carrying hot fluids beyond the temperature rating of harness components.
 - Harnessing should be protected or shielded if routing requires the hose to be exposed to conditions beyond harnessing component specifications.
- Avoid routing harnesses in areas where damage may occur due to build up of material (e.g. dirt, mud, snow, ice, etc.).
- Avoid routing harnesses in areas where the operator or service personnel might step or use as a grab bar.

IMPORTANT: Avoid applying direct spray or pressure washing of electrical components and connections. High pressure streams and sprays can penetrate seals, cause corrosion, or otherwise damage electrical components.
When performing maintenance:

- Inspect electrical components and connectors for corrosion, damaged pins or housings, etc. Repair or replace components or harnessing as necessary.
- Ensure connectors are kept clean and dry. Apply dielectric grease to the sealing surfaces of all connections exposed to moisture, dirt, debris, and other contaminants. Repair or replace harnessing as necessary.
- Clean electrical components with pressurized air, aerosol electrical cleaning agent, or low pressure rinse.
- Remove visible surface water from electrical components and connections using pressurized air or an aerosol cleaning agent. Allow components to dry thoroughly before reconnecting cables.

The Raven Rate Control Module (RCM) is a multi-product application control system built on an ISOBUS platform. The Raven Rate Controller Module is designed to provide a machine operator the ability to simultaneously monitor and control five product applications such as liquid, granular, NH₃, and direct injection via ISOBUS Universal Terminal (UT) and task control for as-applied documentation, prescription rate, and section control.

INSTALLATION BEST PRACTICES

	<p>⚠ WARNING</p> <p>Carefully read and follow all safety requirements and precautions contained in this manual and the machine-specific Installation Manual. Failure to follow safety instructions may lead to equipment damage, personal injury, or death.</p>
--	--

RECOMMENDATIONS

Before installing the RCM™ system, park the machine where the ground is level, clean, and dry.

During the installation process, follow good safety practices. Be sure to carefully read the instructions in this manual as you complete the installation process.

POINT OF REFERENCE

The instructions in this manual assume that you are standing behind the machine, looking toward the cab.

KIT COMPONENTS

This section contains a list of the components that are included in the RCM kit. Before beginning the system installation, compare the items in the kit with the components on this list. If you have questions about the kit, contact your Raven dealer.

FIGURE 1. RCM ARAG Bravo 180S CR7 Cable 3 Sections 2-Wire Valves Kit Components (P/N 117-7100-043 Rev. A)

QTY	PART #	DESCRIPTION
1	053-0159-012	BOX, SHIPPING
1	063-0173-941B	RAVEN RCM, LEVEL1
1	115-0172-616	CABLE, RCM, CAB ISOBUS/PWR
1	115-0172-635	CABLE, RCM TO ARAG PRODUCT CABLE, 3 SECTION, 2 WIRE
1	115-0172-637	CABLE, CR7 TO 9P RECEPTACLE ISO
1	063-0173-080	SWITCH ASSY FOOT ISO PRODUCT CONTROL
1	117-0171-680	KIT, MOUNTING, RCM
1	016-0171-649	SHEET, WARRANTY/HELP
1	016-7100-002	INSTALLATION & CONFIGURATION MANUAL

FIGURE 2. RCM ARAG Bravo 180S CR7 Cable 5 Sections 2-Wire Valves Kit Components (P/N 117-7100-044 Rev. A)

QTY	PART #	DESCRIPTION
1	053-0159-012	BOX, SHIPPING
1	063-0173-941B	RAVEN RCM, LEVEL1
1	115-0172-616	CABLE, RCM, CAB ISOBUS/PWR
1	115-0172-624	CABLE, RCM TO ARAG PRODUCT CABLE, 5 SECTION, 2 WIRE
1	115-0172-637	CABLE, CR7 TO 9P RECEPTACLE ISO
1	063-0173-080	SWITCH ASSY FOOT ISO PRODUCT CONTROL
1	117-0171-680	KIT, MOUNTING, RCM
1	016-0171-649	SHEET, WARRANTY/HELP
1	016-7100-002	INSTALLATION & CONFIGURATION MANUAL

FIGURE 3. RCM ARAG Bravo 180S CR7 Cable 7 Sections 2-Wire Valves Kit Components (P/N 117-7100-045 Rev. A)

QTY	PART #	DESCRIPTION
1	053-0159-012	BOX, SHIPPING
1	063-0173-941B	RAVEN RCM, LEVEL1
1	115-0172-616	CABLE, RCM, CAB ISOBUS/PWR
1	115-0172-625	CABLE, RCM TO ARAG PRODUCT CABLE, 7 SECTION, 2 WIRE
1	115-0172-637	CABLE, CR7 TO 9P RECEPTACLE ISO
1	063-0173-080	SWITCH ASSY FOOT ISO PRODUCT CONTROL
1	117-0171-680	KIT, MOUNTING, RCM
1	016-0171-649	SHEET, WARRANTY/HELP
1	016-7100-002	INSTALLATION & CONFIGURATION MANUAL

FIGURE 4. RCM ARAG Bravo 180S CR7 Cable 6/7 Sections 3-Wire Valves Kit Components (P/N 117-7100-046 Rev. A)

QTY	PART #	DESCRIPTION
1	053-0159-012	BOX, SHIPPING
1	063-0173-941B	RAVEN RCM, LEVEL1
1	115-0172-616	CABLE, RCM, CAB ISOBUS/PWR
1	115-0172-630	CABLE, RCM TO ARAG PRODUCT CABLE, 6/7 SECTION, 3 WIRE
1	115-0172-637	CABLE, CR7 TO 9P RECEPTACLE ISO
1	063-0173-080	SWITCH ASSY FOOT ISO PRODUCT CONTROL
1	117-0171-680	KIT, MOUNTING, RCM
1	016-0171-649	SHEET, WARRANTY/HELP
1	016-7100-002	INSTALLATION & CONFIGURATION MANUAL

UPDATES

Updates for Raven manuals as well as software updates for Raven consoles, and product controllers are available at the Applied Technology Division web site:

<https://portal.ravenprecision.com>

Sign up for e-mail alerts to receive notifications when updates for your Raven products are available on the Raven web site.

At Raven Industries, we strive to make your experience with our products as rewarding as possible. One way to improve this experience is to provide us with feedback on this manual.

Your feedback will help shape the future of our product documentation and the overall service we provide. We appreciate the opportunity to see ourselves as our customers see us and are eager to gather ideas on how we have been helping or how we can do better.

To serve you best, please send an email with the following information to

techwriting@ravenind.com

- RCM ARAG Installation Manual with Manual Guidance
- 016-7100-002 Rev. A
- Any comments or feedback (include chapter or page numbers if applicable).
- Let us know how long have you been using this or other Raven products.

We will not share your email or any information you provide with anyone else. Your feedback is valued and extremely important to us.

Thank you for your time.

INSTALL 500S AND 700S

The RCM can be used with the 500S and 700S and internal GPS.

Ensure the installer follows all of the following guidelines for best installation practices:

- Mount the GPS-antenna with the connectors pointing to the backside.
- Mount the GPS-antenna in front of the rear axle.
- Mount the GPS-antenna on the centerline of the cab/tractor.
- When connecting a 500S antenna, use the 115-0172-588 adapter.
- When connecting a 700S antenna, use the 115-0172-589 adapter.

FIGURE 1. Mounted 500S Antenna



FIGURE 2. 700S Mounting Plate and Antenna

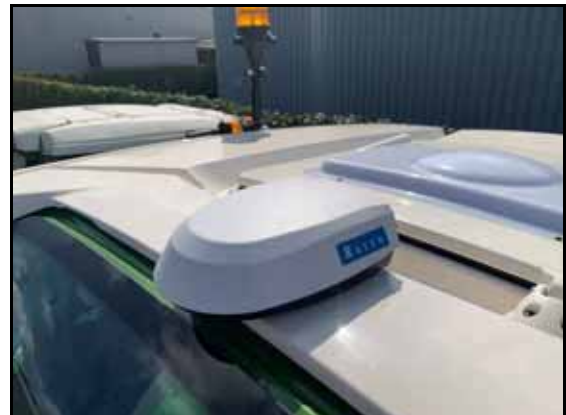

INSTALL CR7

Ensure the installer follows all of the following guidelines for best installation practices.

- Always ensure the terminal is placed in the most appropriate position facing the driver seat for easy access and use.
- Always use a RAM-C ball attachment.
- Mount the terminal with a solid bracket in a place free of vibrations.
- Secure all cables in the cabin so there are no free-hanging cables.
- Ensure the driver has a clear, unobstructed view all around the cabin.

FIGURE 3. CR7 Mounted in Various Positions



INSTALL THE RCM

BEST MOUNTING PRACTICES

Ensure the installer follows all of the following guidelines for best mounting practices:

- Use the standard RCM mounting bracket (P/N 107-0172-484).
- By default, the orientation of the RCM is set to horizontal position with connectors pointing downwards, ensuring that water or moisture will not enter the connectors.

FIGURE 4. Mounted RCM Node



ROUTE AND CONNECT THE CABLES

1. Connect the CR7 to 500s cable (P/N 155-0172-373) to the power and GPS connector on the CR7 console.
2. Connect the power and GPS connector of the CR7 harness (P/N 115-8000-337) to the CR7 console.
3. Connect the CR7 to 9P ISO cable (P/N 115-0172-637) to the I/O connector on the CR7 console.
4. Rotate and connect the RCM power cable (P/N 115-0172-616) to the gray male connector on the RCM.

FIGURE 5. RCM Power Cable Connected



5. Connect the 23 and 35-pin black connectors from the RCM to ARAG cable (P/N 115-0172-(624, 625, 626)) to the black connectors on the RCM.

FIGURE 6. RCM to ARAG Cable Connected



6. Connect the 9-pin ISO connector of RCM Cab ISOBUS Power cable (P/N 115-0172-616) to the 9-pin connector on the CR7 to 9P ISO cable (P/N 115-0172-637).

FIGURE 7. Cable Connected to 9-Pin ISO Connector



7. Disconnect the ARAG product cable from the Bravo 180s field computer.

FIGURE 8. ARAG Product Cable on Bravo 180s Field Computer



8. Connect the other end of the RCM to ARAG Product Cable (P/N 115-0172-(624, 625, 626)) to the ARAG product cable.

FIGURE 9. RCM to ARAG Product Cable Connected to ARAG Product Cable



9. Locate the COBO power socket in the tractor.
10. Connect the RCM in-cab ISOBUS power cable (P/N 115-0172-616) to the COBO power socket.

NOTE: For setting the sprayer profile in the RCM module, please refer to the *Raven Rate Control Module (RCM) Operation Manual* (P/N 016-0171-637).

SYSTEM DRAWINGS

FIGURE 10. RCM ARAG, 3 Sections, 2-Wire Valve w/ CR7 ISO Cable System Drawing (P/N 054-7100-043 Rev. A)

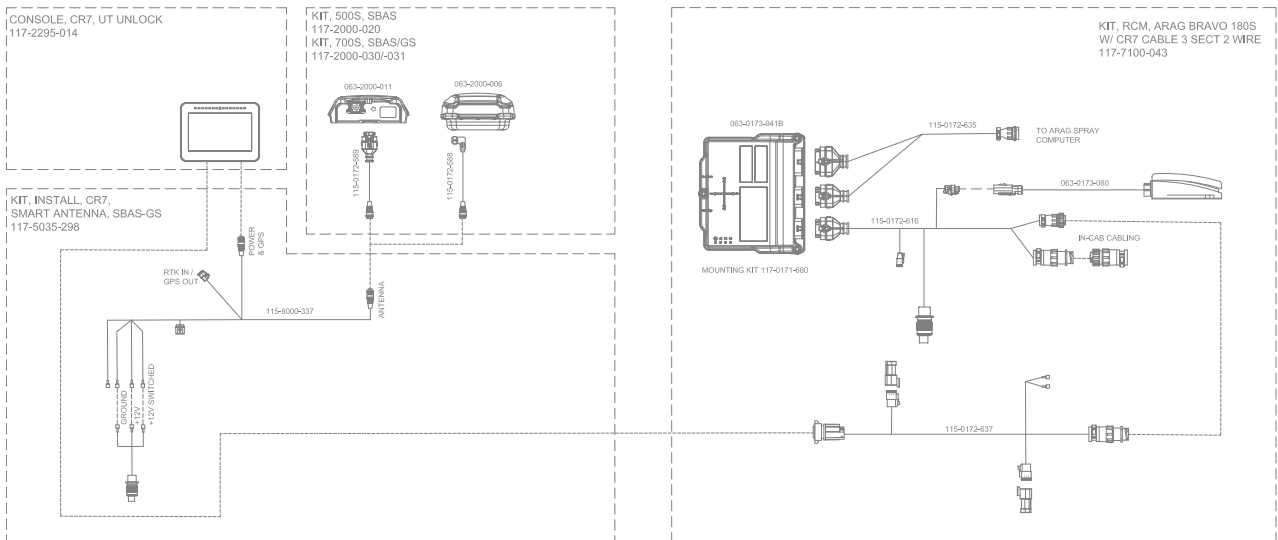

FIGURE 11. RCM ARAG, 5 Sections, 2-Wire Valve w/ CR7 ISO Cable System Drawing (P/N 054-7100-044 Rev. A)

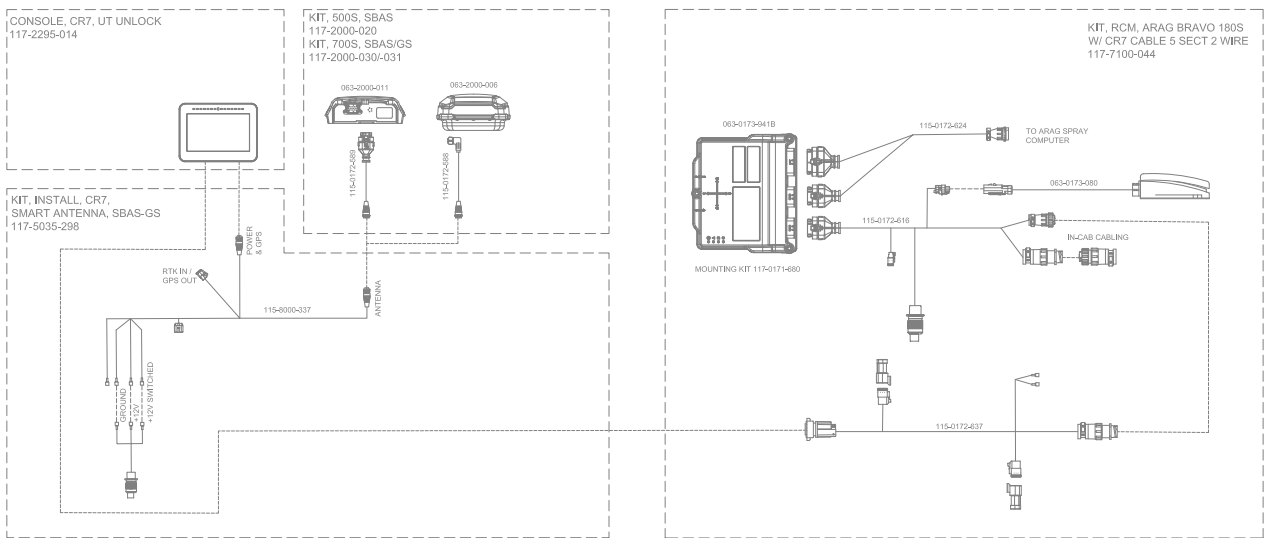

FIGURE 12. RCM ARAG, 7 Sections, 2-Wire Valve w/ CR7 ISO Cable System Drawing (P/N 054-7100-045 Rev. A)

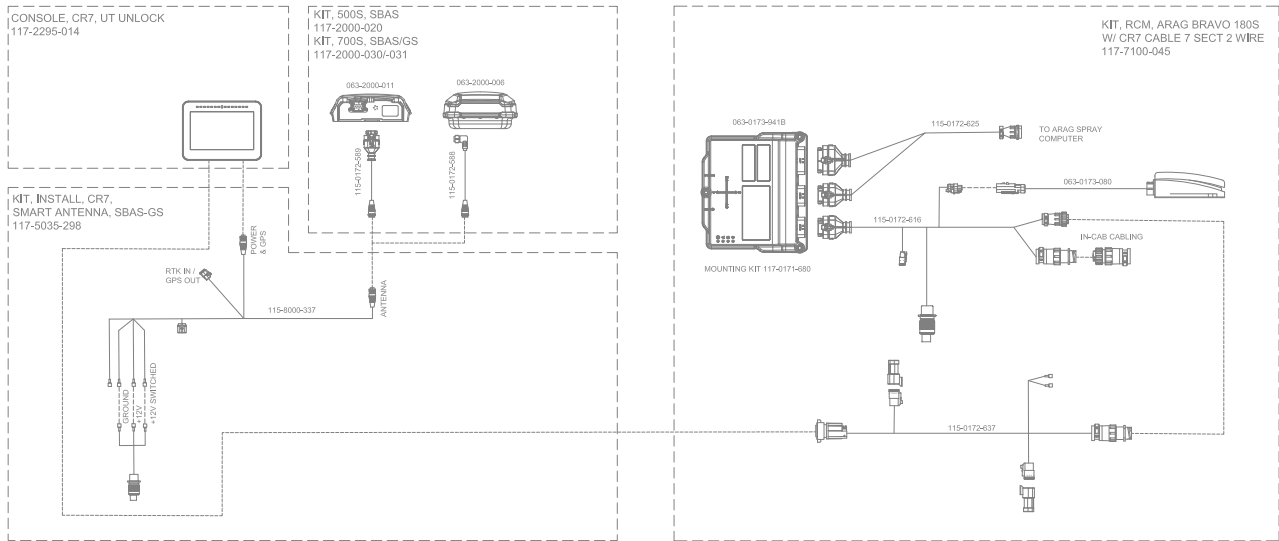
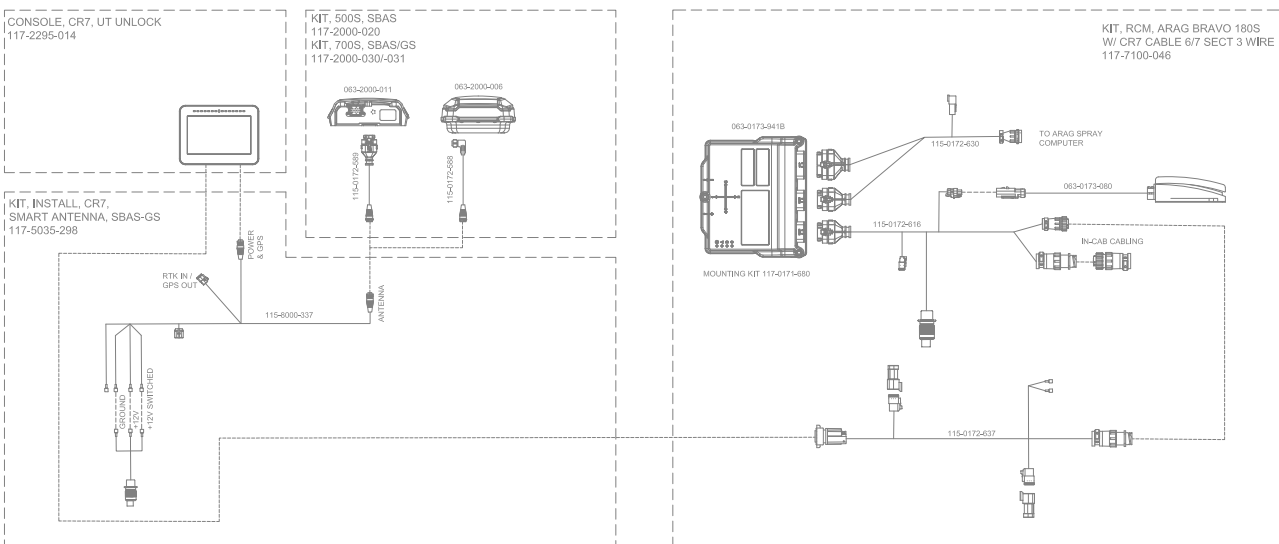

FIGURE 13. RCM ARAG, 6/7 Sections, 3-Wire Valve w/ CR7 ISO Cable System Drawing (P/N 054-7100-046 Rev. A)



H

Hydraulic
Fittings 8

I

Introduction
Installation
Recommendations 5
Point of Reference 5

U

Updates 8

LIMITED WARRANTY

WHAT DOES THIS WARRANTY COVER?

This warranty covers all defects in workmanship or materials in your Raven Applied Technology Division product under normal use, maintenance, and service when used for intended purpose.

HOW LONG IS THE COVERAGE PERIOD?

Raven Applied Technology products are covered by this warranty for 12 months from the date of retail sale. In no case will the Limited Warranty period exceed 24 months from the date the product was issued by Raven Industries Applied Technology Division. This warranty coverage applies only to the original owner and is non-transferable.

HOW CAN I GET SERVICE?

Bring the defective part and proof of purchase to your Raven dealer. If the dealer approves the warranty claim, the dealer will process the claim and send it to Raven Industries for final approval. The freight cost to Raven Industries will be the customer's responsibility. The Return Materials Authorization (RMA) number must appear on the box and all documentation (including proof of purchase) must be included inside the box to be sent to Raven Industries.

WHAT WILL RAVEN INDUSTRIES DO?

Upon confirmation of the warranty claim, Raven Industries will (at our discretion) repair or replace the defective product and pay for the standard return freight, regardless of the inbound shipping method. Expedited freight is available at the customer's expense.

WHAT IS NOT COVERED BY THIS WARRANTY?

Raven Industries will not assume any expense or liability for repairs made outside our facilities without written consent. Raven Industries is not responsible for damage to any associated equipment or products and will not be liable for loss of profit, labor, or other damages. The obligation of this warranty is in lieu of all other warranties, expressed or implied, and no person or organization is authorized to assume any liability for Raven Industries.

Damages caused by normal wear and tear, misuse, abuse, neglect, accident, or improper installation and maintenance are not covered by this warranty.

EXTENDED WARRANTY

WHAT DOES THIS WARRANTY COVER?

This warranty covers all defects in workmanship or materials in your Raven Applied Technology Division product under normal use, maintenance, and service when used for intended purpose.

DO I NEED TO REGISTER MY PRODUCT TO QUALIFY FOR THE EXTENDED WARRANTY?

Yes. Products/systems must be registered within 30 days of retail sale to receive coverage under the Extended Warranty. If the component does not have a serial tag, the kit it came in must be registered instead.

WHERE CAN I REGISTER MY PRODUCT FOR THE EXTENDED WARRANTY?

To register, go online to www.ravenhelp.com and select Product Registration.

HOW LONG IS THE EXTENDED WARRANTY COVERAGE PERIOD?

Raven Applied Technology products that have been registered online are covered for an additional 12 months beyond the Limited Warranty for a total coverage period of 24 months from the date of retail sale. In no case will the Extended Warranty period exceed 36 months from the date the product was issued by Raven Industries Applied Technology division. This Extended Warranty coverage applies only to the original owner and is non-transferable.

HOW CAN I GET SERVICE?

Bring the defective part and proof of purchase to your Raven dealer. If the dealer approves the warranty claim, the dealer will process the claim and send it to Raven Industries for final approval. The freight cost to Raven Industries will be the customer's responsibility. The Return Materials Authorization (RMA) number must appear on the box and all documentation (including proof of purchase) must be included inside the box to be sent to Raven Industries. In addition, the words "Extended Warranty" must appear on the box and all documentation if the failure is between 12 and 24 months from the retail sale.

WHAT WILL RAVEN INDUSTRIES DO?

Upon confirmation of the product's registration for the Extended Warranty and the claim itself, Raven Industries will (at our discretion) repair or replace the defective product and pay for the standard return freight, regardless of the inbound shipping method. Expedited freight is available at the customer's expense.

WHAT IS NOT COVERED BY THE EXTENDED WARRANTY?

Raven Industries will not assume any expense or liability for repairs made outside our facilities without written consent. Raven Industries is not responsible for damage to any associated equipment or products and will not be liable for loss of profit, labor, or other damages. Cables, hoses, software enhancements, and remanufactured items are not covered by this Extended Warranty. The obligation of this warranty is in lieu of all other warranties, expressed or implied, and no person or organization is authorized to assume any liability for Raven Industries.

Damages caused by normal wear and tear, misuse, abuse, neglect, accident, or improper installation and maintenance are not covered by this warranty.