

# SC1 Installation Manual for John Deere 5R (Autotrak-Ready) Model Year 2019 and Newer

016-5034-243 Rev. A

10/2020

E35662



## DISCLAIMER

While every effort has been made to ensure the accuracy of this document, Raven Industries assumes no responsibility for omissions and errors. Nor is any liability assumed for damages resulting from the use of information contained herein.

Raven Industries shall not be responsible or liable for incidental or consequential damages or a loss of anticipated benefits or profits, work stoppage or loss, or impairment of data arising out of the use, or inability to use, this system or any of its components. Raven Industries shall not be held responsible for any modifications or repairs made outside our facilities, nor damages resulting from inadequate maintenance of this system.

As with all wireless and satellite signals, several factors may affect the availability and accuracy of wireless and satellite navigation and correction services (e.g. GPS, GNSS, SBAS, etc.). Therefore, Raven Industries cannot guarantee the accuracy, integrity, continuity, or availability of these services and cannot guarantee the ability to use Raven systems, or products used as components of systems, which rely upon the reception of these signals or availability of these services. Raven Industries accepts no responsibility for the use of any of these signals or services for other than the stated purpose.

---

<b>Chapter 1</b>	<b>Important Information.....</b>	<b>1</b>
Safety .....		1
Displays and Control Consoles .....		1
Electrical safety .....		2
Touch Screen .....		2
Recommendations and Best Practices .....		2
Harness Routing .....		2
<b>Chapter 2</b>	<b>Introduction.....</b>	<b>5</b>
Installation Best Practices .....		5
Recommendations .....		6
Point of Reference .....		6
Kit Components .....		6
Updates .....		8
<b>Chapter 3</b>	<b>Installation .....</b>	<b>9</b>
Mount the Harness .....		9
Install the SC1 .....		14
Best Mounting Practices .....		14
Install 500S and 700S .....		15
Install Slingshot Field Hub .....		16
Install CR7 or CR12 .....		18
Install Field Computer Harness .....		19
System Drawings .....		20



## SAFETY

### **NOTICE**

Follow the operation and safety instructions included with the implement and/or controller and read this manual carefully before installing or operating this Raven system.

- Follow all safety information presented within this manual. Review implement operation with your local dealer.
- Contact a local Raven dealer for assistance with any portion of the installation, service, or operation of Raven equipment.
- Follow all safety labels affixed to system components. Be sure to keep safety labels in good condition and replace any missing or damaged labels. Contact a local Raven dealer to obtain replacements for safety labels.

Observe the following safety measures when operating the implement after installing this Raven system:

- Do not operate this Raven system or any agricultural equipment while under the influence of alcohol or an illegal substance.
- Be alert and aware of surroundings and remain in the operator seat at all times when operating this Raven system.
  - Do not operate the implement on any public road with this Raven system enabled.
  - Disable this Raven system before exiting the operator seat.
  - Determine and remain a safe working distance from obstacles and bystanders. The operator is responsible for disabling the system when a safe working distance has diminished.
  - Disable this Raven system prior to starting any maintenance work on the implement or components of this Raven system.
- Do not attempt to modify or lengthen any of the system control cables. Extension cables are available from a local Raven dealer.

## DISPLAYS AND CONTROL CONSOLES

- If the display will not be used for an extended period, it is best to remove the display from the machine and store it in a climate controlled environment. This may help to extend the service life of electronic components.
- To prevent theft, secure the display and GPS antenna when leaving the machine unattended.

## CAUTION

### ELECTRICAL SAFETY

- Always verify that power leads are connected to the correct polarity as marked. Reversing the power leads could cause severe damage to the Raven system or other components.
- To prevent personal injury or fire, replace defective or blown fuses with only fuses of the same type and amperage.
- Do not connect the power leads to the battery until all system components are mounted and all electrical connections are completed.
- Always start the machine before initializing this Raven system to prevent power surges or peak voltage.
- To avoid tripping and entanglement hazards, route cables and harnesses away from walkways, steps, grab bars, and other areas used by the operator or service personnel when operating or servicing the equipment.

### TOUCH SCREEN

- Only touch the touch-screen with your finger or by using a special touch-screen stylus/pen. Operating the touch-screen with sharp objects may cause permanent damage to the screen.
- Only clean the screen using a damp cloth. Never use caustic or other aggressive substances.

---

## RECOMMENDATIONS AND BEST PRACTICES

### HARNESS ROUTING

The word “harness” is used to describe any electrical cables and leads, both bundled and unbundled. Use the following guidelines and recommendations when connecting and routing harnesses while installing or maintaining this Raven system:

- Leave protective caps/covers over harness connectors until needed to avoid dirt and moisture from contaminating electrical circuits.
- Secure the harness to the frame or solid structural members at least every 12 in [30 cm].
- Follow existing harness runs already routed on the implement as much as possible. Proper harness routing should:
  - Secure harnessing and prevent the harness from hanging below the implement.
  - Provide sufficient clearance from moving components and operational zones around shafts; universal joints and suspension components; pulleys, gears, belts, and chains; moving linkages, cylinders, articulation joints, etc.
  - Protect harnessing from field debris and surrounding hazards (e.g. tree limbs, fence posts, crop stubble, dirt clumps or rocks that may fall or be thrown by the implement).
  - Protect harnessing from sharp bends, twisting, or flexing over short distances and normal implement operation.
  - Connectors and splices should not be located at bending points or in harness sections that move.
  - Ensure sufficient length for free movement of the implement during normal operation and prevent pulling, pinching, catching, or rubbing, especially in articulation and pivot points. Clamp harnessing securely to force controlled movement of the harness.

- Avoid abrasive surfaces and sharp edges such as sheared or flame cut corners, fastener threads or cap screw heads, hose clamp ends, etc.
- Do not connect, affix, or allow harnessing to come into contact with components with high vibration forces, hot surfaces, or components carrying hot fluids beyond the temperature rating of harness components.
  - Harnessing should be protected or shielded if routing requires the hose to be exposed to conditions beyond harnessing component specifications.
- Avoid routing harnesses in areas where damage may occur due to build up of material (e.g. dirt, mud, snow, ice, etc.).
- Avoid routing harnesses in areas where the operator or service personnel might step or use as a grab bar.

**IMPORTANT:** Avoid applying direct spray or pressure washing of electrical components and connections. High pressure streams and sprays can penetrate seals, cause corrosion, or otherwise damage electrical components.  
When performing maintenance:

- Inspect electrical components and connectors for corrosion, damaged pins or housings, etc. Repair or replace components or harnessing as necessary.
- Ensure connectors are kept clean and dry. Apply dielectric grease to the sealing surfaces of all connections exposed to moisture, dirt, debris, and other contaminants. Repair or replace harnessing as necessary.
- Clean electrical components with pressurized air, aerosol electrical cleaning agent, or low pressure rinse.
- Remove visible surface water from electrical components and connections using pressurized air or an aerosol cleaning agent. Allow components to dry thoroughly before reconnecting cables.





---

# CHAPTER

# INTRODUCTION

## 2

---

Congratulations on your purchase of the Raven SC1™ system! This system is designed to provide cutting-edge, hands-free steering of the machine via Global Positioning System (GPS) coordinates.

This manual applies to the following machines. For future reference, write your serial number in the space below.

**Make.** John Deere

**Model.** 5R Autotrak Ready

**FIGURE 1. John Deere Tractor**

---



---

## INSTALLATION BEST PRACTICES



### **WARNING**

Carefully read and follow all safety requirements and precautions contained in this manual and the machine-specific Installation Manual. Failure to follow safety instructions may lead to equipment damage, personal injury, or death.

RECOMMENDATIONS

Before installing the SC1™ system, park the machine where the ground is level, clean, and dry. Bleed pressure from the hydraulic system and leave the machine turned off for the duration of the installation process.

During the installation process, follow good safety practices. Be sure to carefully read the instructions in this manual as you complete the installation process.

Raven Industries recommends the following best practices when installing or operating the SC1™ system for the first time, at the start of the season, or when moving the SC1™ system to another machine:

- Verify that the machine’s hydraulic system is using fresh oil and that the filters have been recently changed
- Ensure there are no issues with the machine’s hydraulic system (e.g., pump issues, faulty hydraulic motors, fine metal deposits in the hydraulic hoses, etc.).

POINT OF REFERENCE

The instructions in this manual assume that you are standing behind the machine, looking toward the cab.

KIT COMPONENTS

This section contains a list of the components that are included in the SC1 kit. Before beginning the system installation, compare the items in the kit with the components on this list. If you have questions about the kit, contact your Raven dealer.

FIGURE 2. John Deere 5R CR7 and SC1 Kit Components (P/N 117-5034-243 Rev. A)

QTY	PART #	DESCRIPTION
1	063-0174-070	ECU, ISO, TC1, LOW SPEED STEERING
1	115-8000-383	CABLE, JUMPER, DTM12SC, SC1 W/ CRX
1	115-4010-177	CABLE, SC1, 9P ISO INCAB
1	115-7300-151	CBL, CR7, ISO VT ONLY, JD STR
1	117-8000-255	KIT, BRACKET, NODE, SEAT MOUNT
1	063-2000-010	ASSEMBLY, 700S, MACHINE BRACKET
1	107-8000-060	BRACKET, RAM, FLAT 120MM
1	117-8000-341	KIT, MOUNTING, TRACTOR
1	115-8000-381	CABLE, JUMPER, DT8P, CBL-377 TO HDU
1	063-0173-887	ECU, HYDRAULIC DRIVER UNIT HDU
1	115-8000-456	CABLE, JOHN DEERE, AUTOTRAC READY W/HDU
1	107-8000-006	BRACKET, STU, MANIFOLD V3
1	115-8000-246	HRNS, JD 8R STR ENCODER
1	115-8000-396	HARNESS, HDU, JOHN DEERE R-SERIES AUTOTRAC READY, SW
1	115-8000-460	HARNESS, WAS SPY, JOHN DEERE 5R
1	115-8000-193	HARNESS, WAS, 1.5M
1	016-5034-243	MANUAL , INSTALLATION, SC1, JOHN DEERE 5R AUTOTRAC R

FIGURE 3. John Deere 5R CR12 and SC1 Kit Components (P/N 117-5034-244 Rev. A)

<b>QTY</b>	<b>PART #</b>	<b>DESCRIPTION</b>
1	063-0174-070	ECU, ISO, TC1, LOW SPEED STEERING
1	115-8000-383	CABLE, JUMPER, DTM12SC, SC1 W/ CRX
1	115-4010-177	CABLE, SC1, 9P ISO INCAB
1	115-7300-135	CBL, CONSOLE, VIPER 4 ISO VT
1	117-8000-255	KIT, BRACKET, NODE, SEAT MOUNT
1	063-2000-010	ASSEMBLY, 700S, MACHINE BRACKET
1	107-8000-060	BRACKET, RAM, FLAT 120MM
1	117-8000-341	KIT, MOUNTING, TRACTOR
1	115-8000-381	CABLE, JUMPER, DT8P, CBL-377 TO HDU
1	063-0173-887	ECU, HYDRAULIC DRIVER UNIT HDU
1	115-8000-456	CABLE, JOHN DEERE, AUTOTRAC READY W/HDU
1	107-8000-006	BRACKET, STU, MANIFOLD V3
1	115-8000-246	HRNS, JD 8R STR ENCODER
1	115-8000-396	HARNESS, HDU, JOHN DEERE R-SERIES AUTOTRAC READY, SW
1	115-8000-460	HARNESS, WAS SPY, JOHN DEERE 5R
1	115-8000-193	HARNESS, WAS, 1.5M
1	016-5034-243	MANUAL , INSTALLATION, SC1, JOHN DEERE 5R AUTOTRAC R

FIGURE 4. John Deere 5R CR12, Internal GPS, and SC1 Kit Components (P/N 117-5034-245 Rev. A)

<b>QTY</b>	<b>PART #</b>	<b>DESCRIPTION</b>
1	063-0174-070	ECU, ISO, TC1, LOW SPEED STEERING
1	115-8000-383	CABLE, JUMPER, DTM12SC, SC1 W/ CRX
1	115-4010-177	CABLE, SC1, 9P ISO INCAB
1	115-7300-152	CABLE, V4+, ISO VT, INTERNAL GPS
1	117-8000-255	KIT, BRACKET, NODE, SEAT MOUNT
1	063-2000-010	ASSEMBLY, 700S, MACHINE BRACKET
1	107-8000-060	BRACKET, RAM, FLAT 120MM
1	117-8000-341	KIT, MOUNTING, TRACTOR
1	115-8000-381	CABLE, JUMPER, DT8P, CBL-377 TO HDU
1	063-0173-887	ECU, HYDRAULIC DRIVER UNIT HDU
1	115-0171-891	CABLE, 10' EXTENSION RS232 STRAIGHT THRU
1	115-8000-456	CABLE, JOHN DEERE, AUTOTRAC READY W/HDU
1	107-8000-006	BRACKET, STU, MANIFOLD V3
1	115-8000-246	HRNS, JD 8R STR ENCODER
1	115-8000-396	HARNESS, HDU, JOHN DEERE R-SERIES AUTOTRAC READY, SW
1	115-8000-460	HARNESS, WAS SPY, JOHN DEERE 5R
1	115-8000-193	HARNESS, WAS, 1.5M
1	016-5034-243	MANUAL , INSTALLATION, SC1, JOHN DEERE 5R AUTOTRAC R

## UPDATES

Updates for Raven manuals as well as software updates for Raven consoles, and product controllers are available at the Applied Technology Division web site:

<https://portal.ravenprecision.com>

Sign up for e-mail alerts to receive notifications when updates for your Raven products are available on the Raven web site.

At Raven Industries, we strive to make your experience with our products as rewarding as possible. One way to improve this experience is to provide us with feedback on this manual.

Your feedback will help shape the future of our product documentation and the overall service we provide. We appreciate the opportunity to see ourselves as our customers see us and are eager to gather ideas on how we have been helping or how we can do better.

To serve you best, please send an email with the following information to

[techwriting@ravenind.com](mailto:techwriting@ravenind.com)

- SC1 Installation Manual for John Deere 5R (Autotrac-Ready) Model Year 2019 and Newer
- 016-5034-243 Rev. A
- Any comments or feedback (include chapter or page numbers if applicable).
- Let us know how long have you been using this or other Raven products.

We will not share your email or any information you provide with anyone else. Your feedback is valued and extremely important to us.

Thank you for your time.

**MOUNT THE HARNESS**

1. Locate the steering valve of the tractor, mounted behind the ladder and towards the right side.

**FIGURE 1. Steering Valve Location**

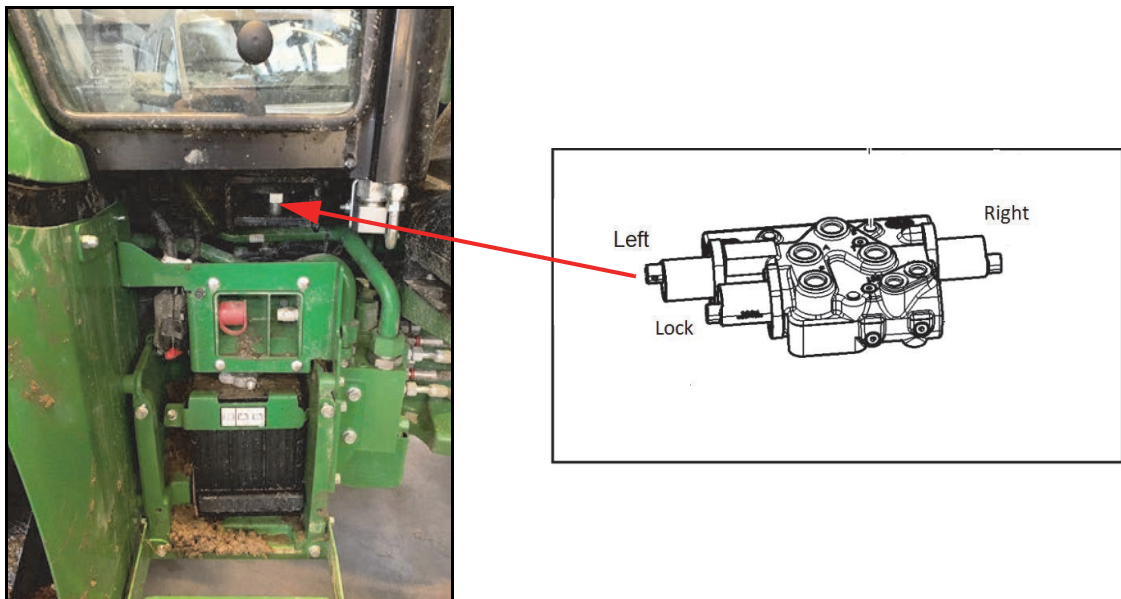

2. Unplug the three connectors from the steering valve ports.

**FIGURE 2. Steering Valve Ports**

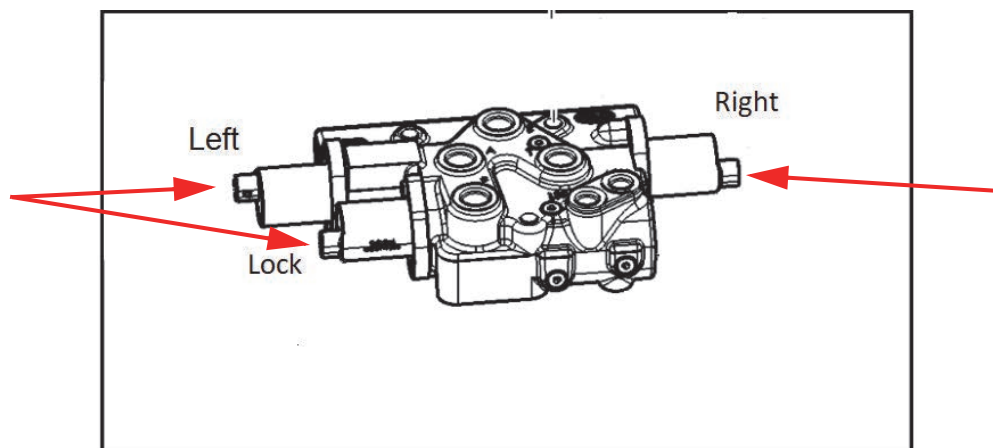
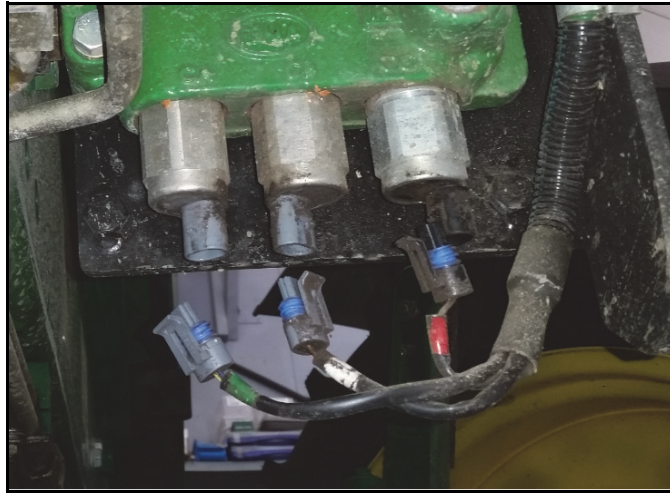

FIGURE 3. Connectors Unplugged from Steering Valve

---



**NOTE:** The example image shown above in Figure 3 is a picture of a John Deere 6R tractor.

3. Plug the unplugged connectors into the ports located on the switchbox cable (P/N 115-8000-396).
4. Connect the connectors from the switchbox to the empty ports of the valve. The switchbox should be connected in between the original connectors of the valve.

FIGURE 4. Switchbox

---



**NOTE:** The example image shown above in Figure 4 is a picture of a John Deere 6R tractor.

5. Mount the HDU near the ladder on the right side of the cab.

**FIGURE 5. Mounted HDU**



6. To access steer encoder connectors, pull down on the sides of the steering column to open the cover.
7. Install the Encoder T-cable (P/N 115-8000-246) between the connectors of the steer encoder of the tractor.
8. Guide the T-cable to the HDU.

**FIGURE 6. T-Cable for Mounted Steer Encoder**

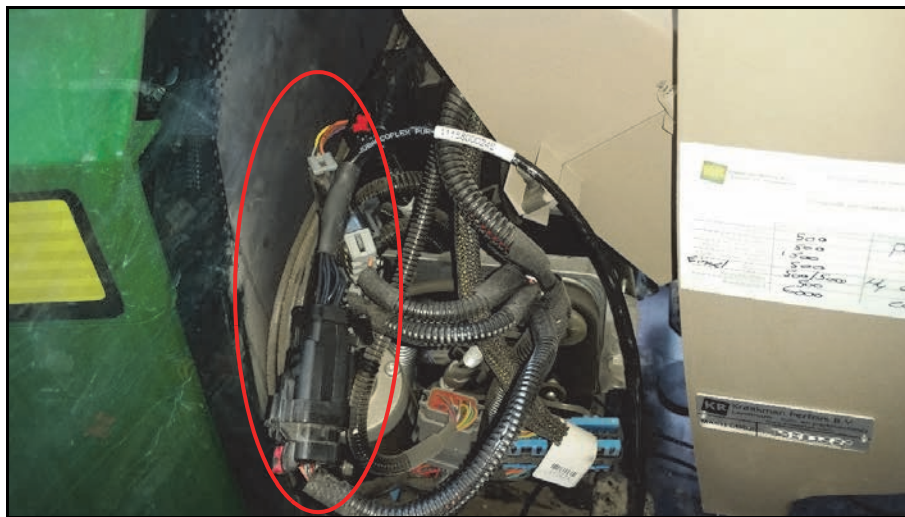

9. To access the wheel angle sensor connector, remove the floor mat and open the floor panel.
10. Install the wheel-angle spy cable between the existing connectors of the wheel angle sensor.

11. Route the remaining connectors to the HDU.

**FIGURE 7. Wheel Sensor Connectors**

---



12. Mount the power harness (P/N 115-8000-456) to the chassis between the battery, HDU, and the ISOBUS connector.
13. Route the cables from the battery to the existing ISOBUS connector at the back of the tractor.
14. Connect the Y-split cables between the 4P connector of the IBBC connector.
15. Connect the gray 12P connector to the HDU mounted near the ladder.

**FIGURE 8. Y-Cable Mounted Between Existing ISOBUS Cable**

---





16. Route the 115-8000-349 cable from the SC1 to the GPS antenna (500S/700S) through the B-pillar to the roof.

**FIGURE 9. Cable Routed to Roof**



17. Connect the antenna cable (P/N 115-8000-349) to the SC1 9-pin in-cab cable (P/N 115-4010-177).

18. Connect the other side of the SC1 9-pin in-cab cable into the 9-pin ISOBUS connector located on the B-pillar.

**FIGURE 10. ISOBUS Connector on B-Pillar**

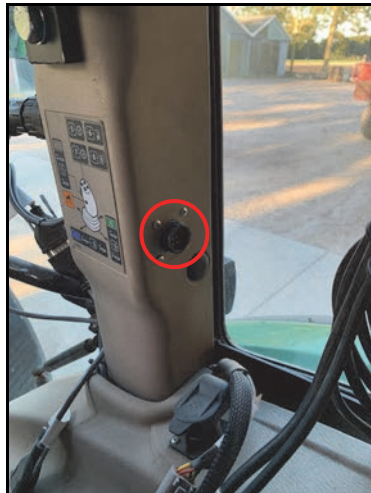

19. Route the cable behind the lining and to the SC1.

## INSTALL THE SC1

### BEST MOUNTING PRACTICES

Ensure the installer follows all of the following guidelines for best mounting practices:

- Use the standard SC1 mounting bracket (P/N 117-8000-255).
- Place the SC1 near the seat, preferably to the right of the seat.
- Mount on the seat bolts. If needed, use two M8 extension nuts to heighten the bracket.
- If the installer is unable to attach the SC1 to the seat bolts, attach the SC1 in the cab in a location that is free from vibrations.
- The SC1 may only be mounted in a horizontal position (with the sticker facing upwards). The connectors may be orientated in four directions: 0, 90, 180, or 270 degrees.
- By default, the orientation of the SC1 is set to horizontal position with connectors pointing towards the rear. Any other orientation should be set properly in the accompanying software.

**FIGURE 11. SC1 Mounted Next to Seat**

---



## INSTALL 500S AND 700S

The SC1 can be used with the 500S and 700S and internal GPS.

Ensure the installer follows all of the following guidelines for best installation practices:

- Mount the GPS-antenna with the connectors pointing to the backside.
- Mount the GPS-antenna in front of the rear axle.
- Mount the GPS-antenna on the centerline of the cab/tractor.
- When connecting a 500S antenna, use the 115-0172-589 cable.
- When connecting a 700S antenna, use the 115-0172-588 cable.

**FIGURE 12. Mounted 500S Antenna**



**FIGURE 13. 700S Mounting Plate and Antenna**

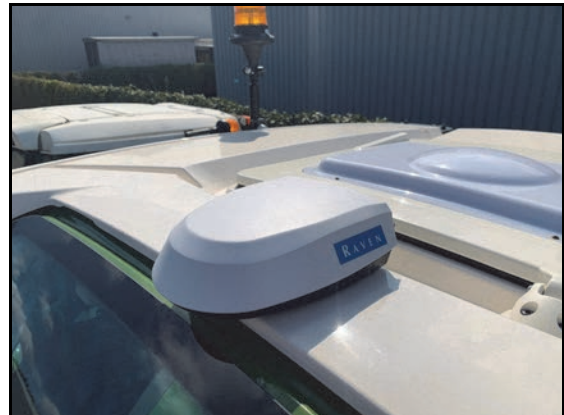

If the antenna is not connected, ensure that the connectors on the roof are covered with a protective cap to prevent dust and water from entering the connector.

**FIGURE 14. Protective Cap**



## INSTALL SLINGSHOT FIELD HUB

Ensure the installer follows all of the following guidelines for best installation practices:

- The GPRS/UMTS antennas are equipped with a magnetic base and must be placed on top of the cabin.
- The antennas should be mounted in a clear, unobstructed area to ensure clear reception.
- To avoid confusion, label the antenna cables inside the cabin with “Cellular” and “Diversity.” Label the GPS patch antenna cable with “GPS” as seen in Figure 15.
- Mount a gray SMA grip on both antenna cable connections and mount a blue SMA grip on the GPS patch antenna cable, also shown in Figure 15, “Labeled Antenna Cables with SMA Grips,”.

FIGURE 15. Labeled Antenna Cables with SMA Grips



FIGURE 16. Field Hub connected with CRx and Viper 4

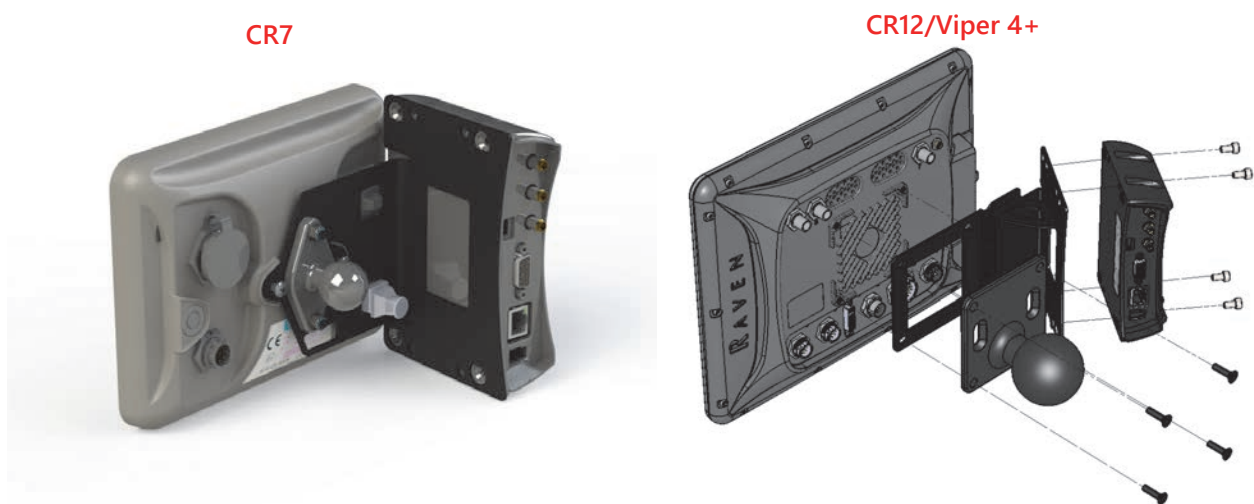

If a Slingshot modem is used, in addition to the GPS-antenna, two GPRS/UMTS antennas and a GPS patch should be mounted.

**NOTE:** Handle the GPS patch with care; the antenna cable is thin and fragile.

The GPRS/UMTS antennas should be mounted as far away from each other as possible. More than 100 cm is recommended.

**FIGURE 17. GPS Patch Antenna and Two GPRS/UMTS Antennas**



If a standard GPS antenna bracket is mounted, one of the GPRS/UMTS antennas should be mounted on this bracket. The second GPRS/UMTS antenna should be mounted on a metal bracket on the cabin.

**FIGURE 18. GPRS/UMTS Mounted**

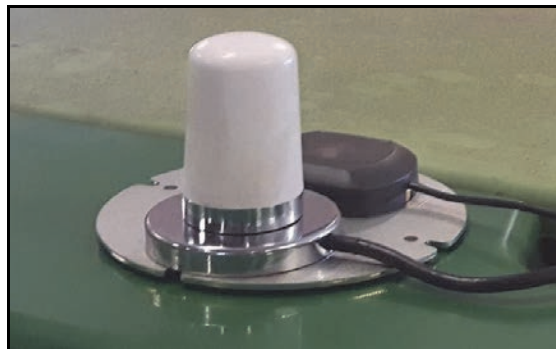

Connect the power cable to the connector with the label "Slingshot PWR." Then connect the RTK IN connector with the GPS OUT connector. Next, connect the Serial RTK IN with the Slingshot. Finally, connect the Ethernet cable between the Slingshot and the CR7.

## INSTALL CR7 OR CR12

Ensure the installer follows all of the following guidelines for best installation practices.

- Always ensure the terminal is placed in the most appropriate position facing the driver seat for easy access and use.
- Always use a RAM-C ball attachment.
- Mount the terminal with a solid bracket in a place free of vibrations.
- Secure all cables in the cabin so there are no free-hanging cables.
- Ensure the driver has a clear, unobstructed view all around the cabin.

FIGURE 19. CR7 Mounted in Various Positions



FIGURE 20. CR12 Mounted in Various Positions



---

## INSTALL FIELD COMPUTER HARNESS

Ensure the installer follows all of the following guidelines for best installation practices.

- Install the field computer harness between the field computer and the standard connectors of the tractor.
- Mount the display cable to the display port panel mount connector into the B-pillar.
- Guide the harness to the field computer.

**FIGURE 21. Display Port on B-Pillar**



SYSTEM DRAWINGS

FIGURE 22. John Deere 5R CR7 & SC1 System Drawing (P/N 054-5034-243 Rev. A)

SYSTEM DRAWING, JOHN DEERE 5R AR, CR7, SC1

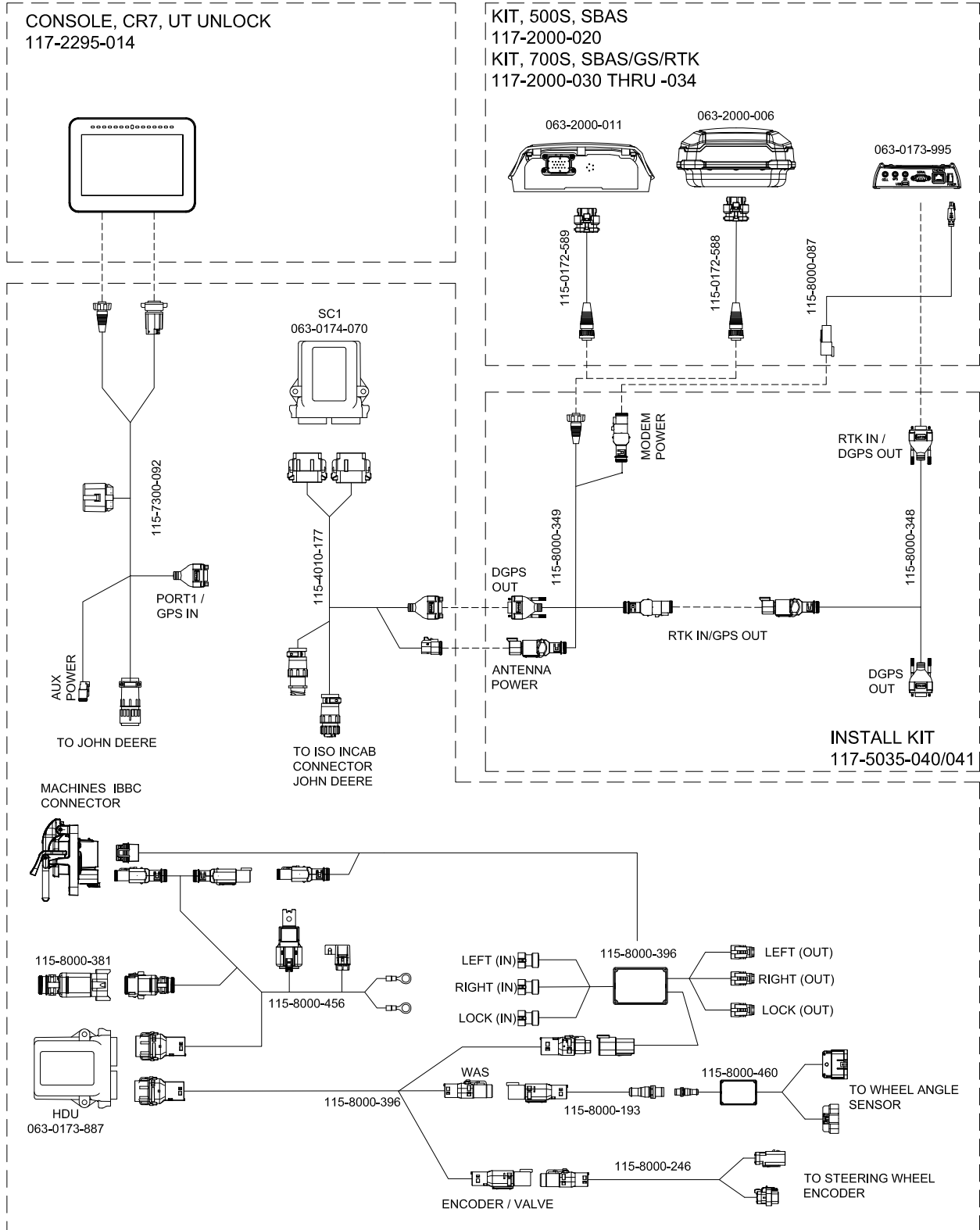



FIGURE 23. John Deere CR12 & SC1 System Drawing (P/N 054-5034-244 Rev. A)

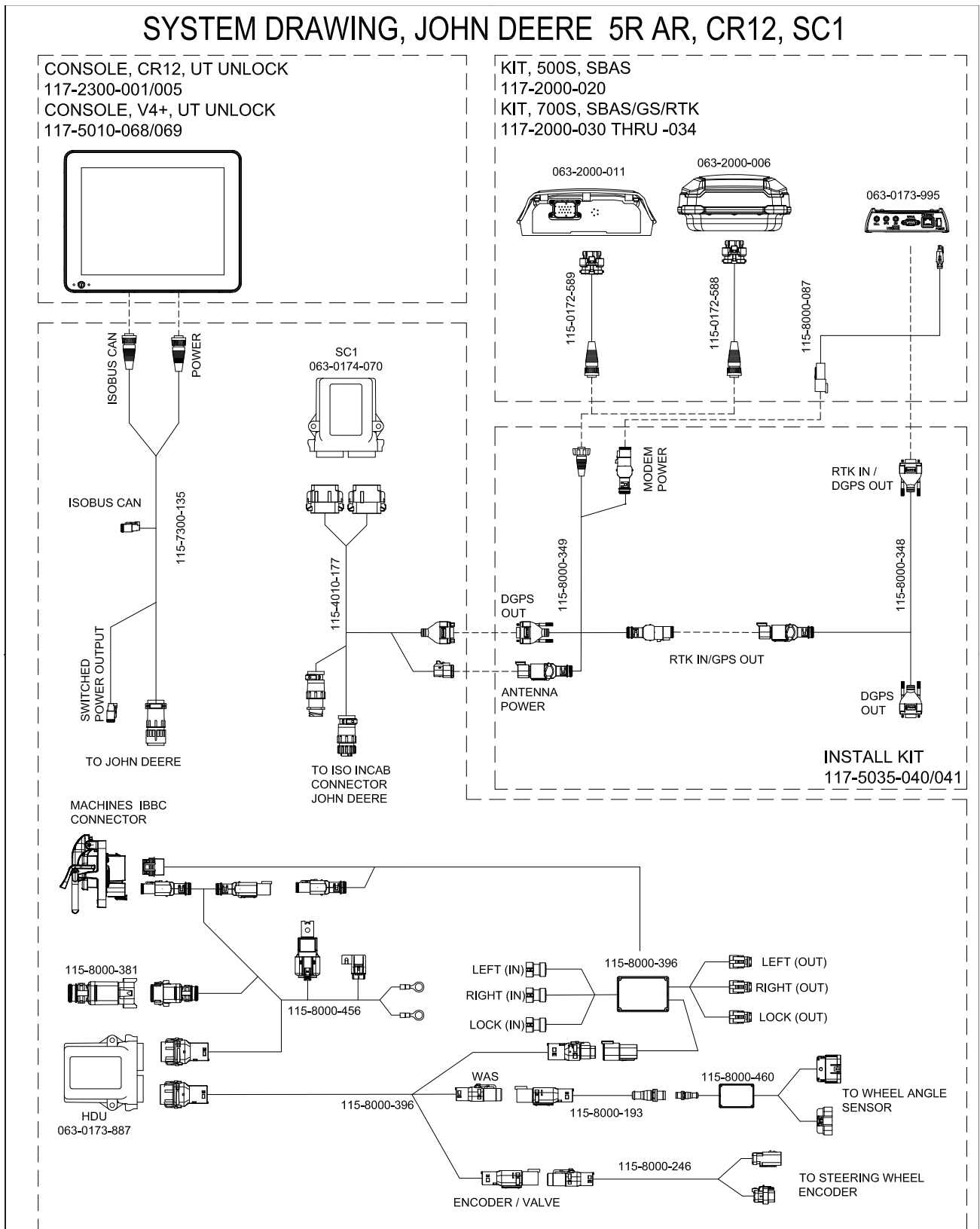
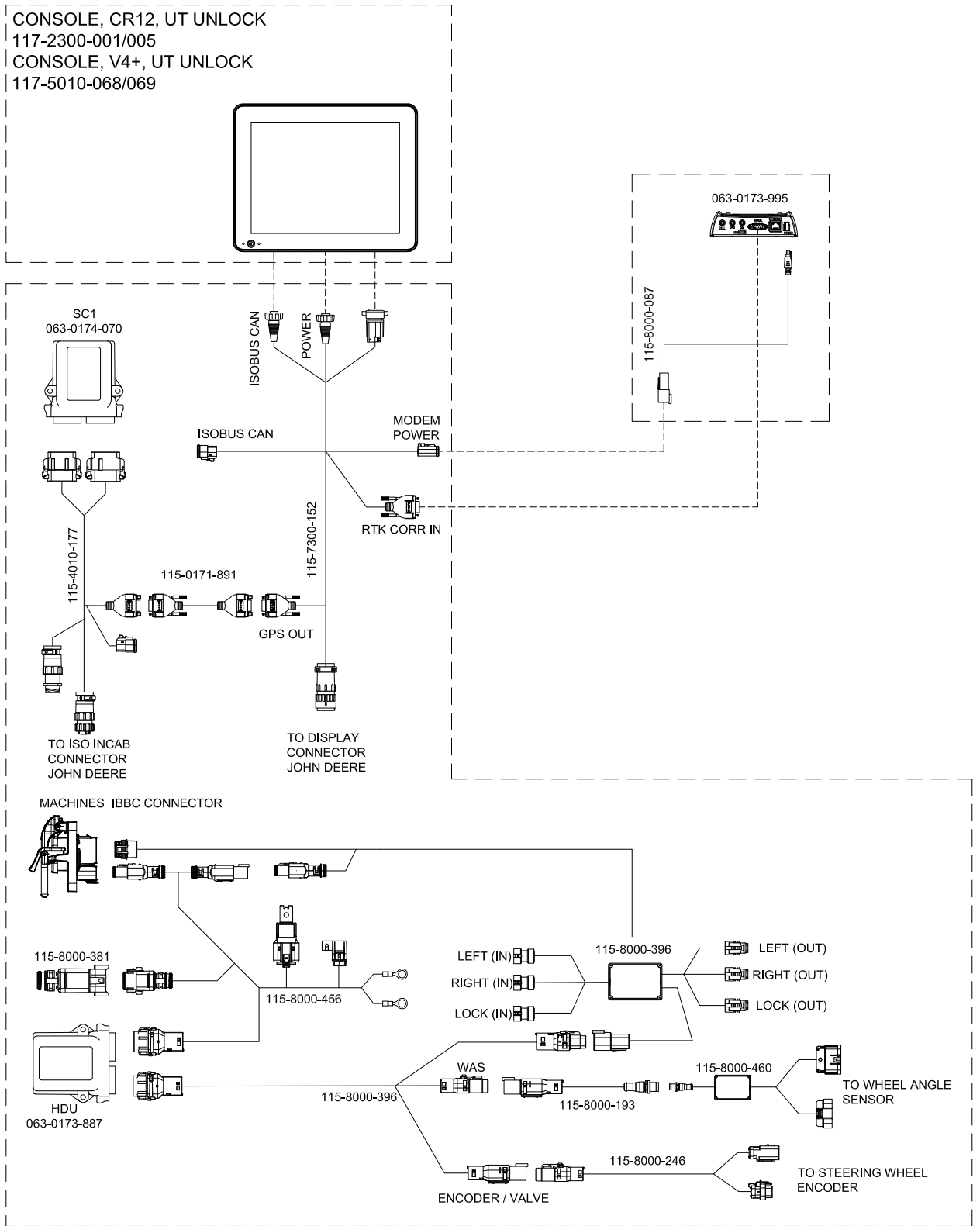

FIGURE 24. John Deere 5R CR12 & SC1 (Internal GPS) System Drawing (P/N 054-5034-245 Rev. A)

SYSTEM DRAWING, JOHN DEERE 5R AR, CR12, INTERNAL GPS SC1



---

## Numerics

500S 15  
700S 15

## C

CR12 18  
CR7 18

## F

Field Hub 16

## H

Harness 9  
HDU 11  
Hydraulic  
Fittings 8

## I

**Introduction**  
Installation  
Recommendations 6  
Point of Reference 6

## S

SC1 14  
Steering Valve 9  
Switchbox 10  
System Drawings 20

## U

Updates 8

## W

Wheel Angle Sensor 11  
Wheel Sensor Connectors 12



# LIMITED WARRANTY

## WHAT DOES THIS WARRANTY COVER?

This warranty covers all defects in workmanship or materials in your Raven Applied Technology Division product under normal use, maintenance, and service when used for intended purpose.

## HOW LONG IS THE COVERAGE PERIOD?

Raven Applied Technology products are covered by this warranty for 12 months from the date of retail sale. In no case will the Limited Warranty period exceed 24 months from the date the product was issued by Raven Industries Applied Technology Division. This warranty coverage applies only to the original owner and is non-transferable.

## HOW CAN I GET SERVICE?

Bring the defective part and proof of purchase to your Raven dealer. If the dealer approves the warranty claim, the dealer will process the claim and send it to Raven Industries for final approval. The freight cost to Raven Industries will be the customer's responsibility. The Return Materials Authorization (RMA) number must appear on the box and all documentation (including proof of purchase) must be included inside the box to be sent to Raven Industries.

## WHAT WILL RAVEN INDUSTRIES DO?

Upon confirmation of the warranty claim, Raven Industries will (at our discretion) repair or replace the defective product and pay for the standard return freight, regardless of the inbound shipping method. Expedited freight is available at the customer's expense.

## WHAT IS NOT COVERED BY THIS WARRANTY?

Raven Industries will not assume any expense or liability for repairs made outside our facilities without written consent. Raven Industries is not responsible for damage to any associated equipment or products and will not be liable for loss of profit, labor, or other damages. The obligation of this warranty is in lieu of all other warranties, expressed or implied, and no person or organization is authorized to assume any liability for Raven Industries.

**Damages caused by normal wear and tear, misuse, abuse, neglect, accident, or improper installation and maintenance are not covered by this warranty.**

# EXTENDED WARRANTY

## WHAT DOES THIS WARRANTY COVER?

This warranty covers all defects in workmanship or materials in your Raven Applied Technology Division product under normal use, maintenance, and service when used for intended purpose.

## DO I NEED TO REGISTER MY PRODUCT TO QUALIFY FOR THE EXTENDED WARRANTY?

Yes. Products/systems must be registered within 30 days of retail sale to receive coverage under the Extended Warranty. If the component does not have a serial tag, the kit it came in must be registered instead.

## WHERE CAN I REGISTER MY PRODUCT FOR THE EXTENDED WARRANTY?

To register, go online to [www.ravenhelp.com](http://www.ravenhelp.com) and select Product Registration.

## HOW LONG IS THE EXTENDED WARRANTY COVERAGE PERIOD?

Raven Applied Technology products that have been registered online are covered for an additional 12 months beyond the Limited Warranty for a total coverage period of 24 months from the date of retail sale. In no case will the Extended Warranty period exceed 36 months from the date the product was issued by Raven Industries Applied Technology division. This Extended Warranty coverage applies only to the original owner and is non-transferable.

## HOW CAN I GET SERVICE?

Bring the defective part and proof of purchase to your Raven dealer. If the dealer approves the warranty claim, the dealer will process the claim and send it to Raven Industries for final approval. The freight cost to Raven Industries will be the customer's responsibility. The Return Materials Authorization (RMA) number must appear on the box and all documentation (including proof of purchase) must be included inside the box to be sent to Raven Industries. In addition, the words "Extended Warranty" must appear on the box and all documentation if the failure is between 12 and 24 months from the retail sale.

## WHAT WILL RAVEN INDUSTRIES DO?

Upon confirmation of the product's registration for the Extended Warranty and the claim itself, Raven Industries will (at our discretion) repair or replace the defective product and pay for the standard return freight, regardless of the inbound shipping method. Expedited freight is available at the customer's expense.

## WHAT IS NOT COVERED BY THE EXTENDED WARRANTY?

Raven Industries will not assume any expense or liability for repairs made outside our facilities without written consent. Raven Industries is not responsible for damage to any associated equipment or products and will not be liable for loss of profit, labor, or other damages. Cables, hoses, software enhancements, and remanufactured items are not covered by this Extended Warranty. The obligation of this warranty is in lieu of all other warranties, expressed or implied, and no person or organization is authorized to assume any liability for Raven Industries.

**Damages caused by normal wear and tear, misuse, abuse, neglect, accident, or improper installation and maintenance are not covered by this warranty.**