

VSN Installation Manual
for Equipment
Technologies Apache
AS840, AS1040, AS1240
MY 18-20

016-2025-003 Rev. A

9/2020

E35424



DISCLAIMER

While every effort has been made to ensure the accuracy of this document, Raven Industries assumes no responsibility for omissions and errors. Nor is any liability assumed for damages resulting from the use of information contained herein.

Raven Industries shall not be responsible or liable for incidental or consequential damages or a loss of anticipated benefits or profits, work stoppage or loss, or impairment of data arising out of the use, or inability to use, this system or any of its components. Raven Industries shall not be held responsible for any modifications or repairs made outside our facilities, nor damages resulting from inadequate maintenance of this system.

As with all wireless and satellite signals, several factors may affect the availability and accuracy of wireless and satellite navigation and correction services (e.g. GPS, GNSS, SBAS, etc.). Therefore, Raven Industries cannot guarantee the accuracy, integrity, continuity, or availability of these services and cannot guarantee the ability to use Raven systems, or products used as components of systems, which rely upon the reception of these signals or availability of these services. Raven Industries accepts no responsibility for the use of any of these signals or services for other than the stated purpose.

Chapter 1	Important Safety Information.....	1
General		2
Instructions for Wire Routing		2
Chapter 2	Introduction.....	5
Preparing for Installation		5
Prerequisites		5
Recommendations		5
Point of Reference		5
Updates		6
Kit Contents		7
Chapter 3	Installation	9
Mounting VSN		9
System Diagram		13
Cable Installation		14
Inside of Cab		14
Outside of Cab		16
Cabling and Connection		19
Optional Ethernet Cable		19

CHAPTER

1

IMPORTANT SAFETY INFORMATION

NOTICE

Read this manual and the operation and safety instructions included with your implement and/or controller carefully before installing the VSN system.

- Follow all safety information presented within this manual.
- If you require assistance with any portion of the installation or service of your Raven equipment, contact your local Raven dealer for support.
- Follow all safety labels affixed to the VSN system components. Be sure to keep safety labels in good condition and replace any missing or damaged labels. To obtain replacements for missing or damaged safety labels, contact your local Raven dealer.

When operating the machine after installing VSN, observe the following safety measures:

- Be alert and aware of surroundings.
- Do not operate VSN or any agricultural equipment while under the influence of alcohol or an illegal substance.
- Remain in the operator's position or a safe working distance away from the booms at all times when VSN is engaged.
- Disable VSN when exiting from the operator's seat and machine.
- Do not drive the machine with VSN enabled on any public road.
- Determine and remain a safe working distance from other individuals. The operator is responsible for disabling VSN when the safe working distance has diminished.
- Ensure VSN is disabled prior to starting any maintenance work on VSN or the machine.

WARNING

- The machine must remain stationary and switched off, with the booms unfolded and supported, during installation or maintenance.

CAUTION

GENERAL

- Always verify that the power leads are connected to the correct polarity as marked. Reversing the power leads could cause severe damage to the equipment.
- Ensure that the power cable is the last cable to be connected.
- A minimum of 12 VDC is required for system operation with a maximum of 15 VDC.

INSTRUCTIONS FOR WIRE ROUTING

The word “harness” is used to mean all electrical leads and cables, bundled and unbundled. When installing harness, secure it at least every 30 cm (12in) to the frame. Follow existing harness as much as possible and use these guidelines:

Harness should not contact or be attached to:

- Lines and hoses with high vibration forces or pressure spikes
- Lines and hoses carrying hot fluids beyond harness component specifications

Avoid contact with any sharp edge or abrading surfaces such as, but not limited to:

- Sheared or flame cut edges
- Edges of machined surfaces
- Fastener threads or cap screw heads
- Ends of adjustable hose clamps
- Wire exiting conduit without protection, either ends or side of conduit
- Hose and tube fittings

Routing should not allow harnesses to:

- Hang below the unit
- Have the potential to become damaged due to exposure to the exterior environment. (i.e. tree limbs, debris, attachments)
- Be placed in areas of or in contact with machine components which develop temperatures higher than the temperature rating of harness components
- Wiring should be protected or shielded if it needs to route near hot temperatures beyond harness component specifications

Harnessing should not have sharp bends

Allow sufficient clearance from machine component operational zones such as:

- Drive shafts, universal joints and hitches (i.e. 3-point hitch)
- Pulleys, gears, sprockets
- Deflection and backlash of belts and chains
- Adjustment zones of adjustable brackets

- Changes of position in RS1 HD and suspension systems
- Moving linkages, cylinders, articulation joints, attachments
- Ground engaging components

For harness sections that move during machine operation:

- Allow sufficient length for free movement without interference to prevent: pulling, pinching, catching or rubbing, especially in articulation and pivot points
- Clamp harnesses securely to force controlled movement to occur in the desired harness section
- Avoid sharp twisting or flexing of harnesses in short distances
- Connectors and splices should not be located in harness sections that move

Protect harnesses from:

- Foreign objects such as rocks that may fall or be thrown by the unit
- Buildup of dirt, mud, snow, ice, submersion in water and oil
- Tree limbs, brush and debris
- Damage where service personnel or operators might step or use as a grab bar
- Damage when passing through metal structures

IMPORTANT:

- Avoid directly spraying electrical components and connections with high pressure water. High pressure water sprays can penetrate seals and cause electrical components to corrode or otherwise become damaged. When performing maintenance:
- Inspect all electrical components and connections for damage or corrosion. Repair or replace components, connections, or cable as necessary.
- Ensure connections are clean, dry, and not damaged. Repair or replace components, connections, or cable as necessary.
- Clean components or connections using low pressure water, pressurized air, or an aerosol electrical component cleaning agent.
- Remove visible surface water from components, connections, or seals using pressurized air or an aerosol electrical component cleaning agent. allow components to dry completely before reconnecting cables.

Congratulations on your purchase of the VSN system!

The following instructions are designed to assist with the proper installation of the VSN system. Refer to the VSN Calibration & Operation Manual (P/N 016-2020-001) for assistance with calibrating and using the VSN system.

PREPARING FOR INSTALLATION

Before installing the VSN system, park the machine where the ground is level, clean, and dry. Turn off the machine and leave it turned off for the duration of the installation process.

During the installation process, follow good safety practices. Be sure to carefully read the instructions in this manual to complete the installation process.

PREREQUISITES

The following components must be installed with the VSN system.

- RS1™
- Viper® 4 with ROS version 3.4 or newer

Follow the installation instructions provided with these components before installing VSN.

RECOMMENDATIONS

Raven Industries recommends the following best practices when installing or operating the VSN system for the first time or at the start of the season:

- Install the VSN unit in the recommended location.
- Use part numbers to help identify parts.
- Do not remove the plastic wrap from a part until it is necessary for installation.

POINT OF REFERENCE

The instructions in this manual assume that you are standing behind the machine, looking toward the cab.

UPDATES

Software and manual updates are available on the Raven Applied Technology website:

<http://www.ravenprecision.com>

At Raven Industries, we strive to make your experience with our products as rewarding as possible. One way to improve this experience is to provide us with feedback on this manual.

Your feedback will help shape the future of our product documentation and the overall service we provide. We appreciate the opportunity to see ourselves as our customers see us and are eager to gather ideas on how we have been helping or how we can do better.

To serve you best, please send an email with the following information to

techwriting@ravenind.com

- VSN Installation Manual for Equipment Technologies Apache AS840, AS1040, AS1240 MY 18-20 -016-2025-003 Rev. A
- Any comments or feedback (include chapter or page numbers if applicable).
- Let us know how long have you been using this or other Raven products.

We will not share your email or any information you provide with anyone else. Your feedback is valued and extremely important to us.

Thank you for your time.

KIT CONTENTS

This section contains a list of the components that are included in the VSN kit. Before beginning the system installation, compare the items in the kit with the components on this list. If you have questions about the kit, contact your Raven dealer.

FIGURE 1. VSN Installation Kit for Apache MY 18-20 (P/N 117-2025-003 Rev. A)

QTY	PART #	DESCRIPTION
1	053-0159-263	PALLET, SHIPPING
1	116-0159-848	WELDMENT, VSN, APACHE AS1240 MY20+
1	053-0159-012	BOX, SHIPPING
1	116-0159-837	WELDMENT, VSN MOUNT
1	116-0159-835	WELDMENT, VSN MOUNT, AGCO B/C
1	115-2020-017	CABLE, VSN, APACHE ASXX30/40 MY18+, MAIN HARNESS TEE
1	115-2020-016	CABLE, VSN, APACHE ASXX30/40 MY18+, CAB ADAPTER
1	107-0172-642	SHIELD, DEBRIS, VSN
1	053-0159-074	ENVELOPE, PLASTIC
8	311-4055-180N	BOLT, M8-1.25 X 25MM, CLASS V COATING
4	313-6001-013N	WASHER, LOCK, M8, CLASS V COATING
12	313-6000-013N	WASHER, M8, CLASS V COATING
4	312-6001-027N	NUT, NYLOC, M8-1.25, CLASS V COATING
8	311-0054-081	3/8-16X1 1/4" LG UNC-2 MAGNICOAT BOLTS
16	313-2300-014	3/8" WASHER, STEEL, FLAT, HIGH CORROSION RESISTANT
8	312-4000-097	3/8" NUT, LOCK, NYLON INSERT
2	311-0062-156	3/4"-10 X 3" LG GRADE 8 BOLT
2	313-2300-023	3/4" WASHER, STEEL, FLAT, HIGH CORROSION RESISTANT
4	313-5001-007	GASKET, VITON, .29 I.D. X .688 O.D. X .062 THK



MOUNTING VSN

1. Open the hood and remove the four bolts on the frame of the machine on the left side.

FIGURE 1. Four Bolts on Frame



2. Using the two supplied 3/4"-10x3" long bolts and washers, mount the VSN weldment bracket (P/N 116-0159-848) to the frame of the machine.

NOTE: Use the supplied bolts and washers in the top holes and the longer of the bolts removed in the bottom two bolts.

Secure the bolts with the nuts previously removed from the machine.

FIGURE 2. VSN Weldment Bracket Mounted to Frame



NOTE: Ensure the VSN weldment bracket is mounted and positioned level to the frame of the machine.

FIGURE 3. VSN Weldment Bracket Level with Frame



3. Mount the 116-0159-835 bracket to the VSN weldment bracket using the supplied 3/8" bolts, washers, and lock nuts.

FIGURE 4. Bracket Mounted to the VSN Weldment



4. Mount the 116-0159-837 bracket to the back of the VSN with the included dust shield, M8 bolts, washers, lock washers, and rubber isolators.

FIGURE 5. Camera Assembly

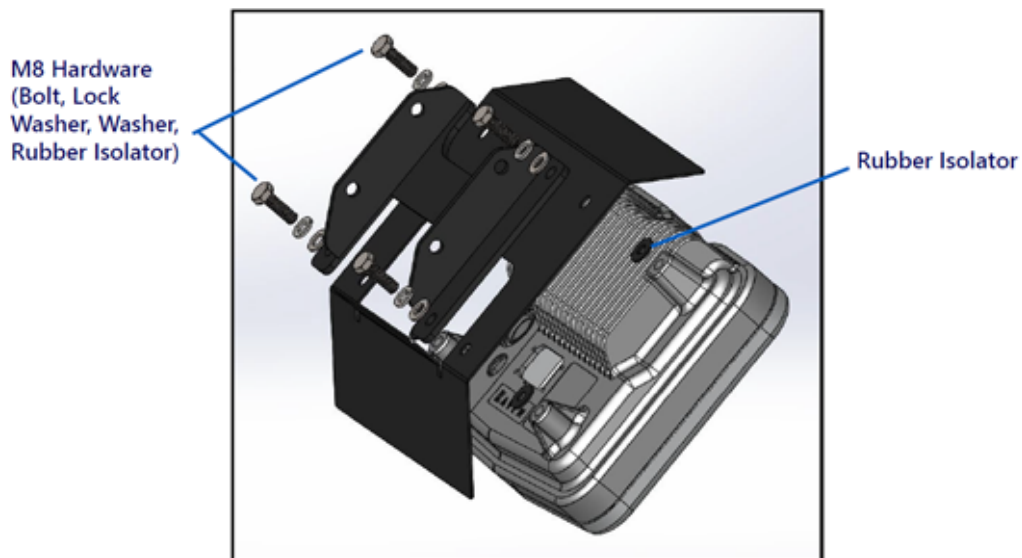

5. Mount the VSN Visual Guidance camera assembly to the installed camera mounting bracket (116-0159-835) using the provided M8 hardware.
 - a. Qty. 4 – 311-4055-180N – M8 x 25MM Bolt.
 - b. Qty. 8 – 313-6000-013N – M8 Flat Washer.
 - c. Qty. 4 – 312-6001-027N – M8 x 1.25 Nylock Nut.

FIGURE 6. Installed Camera Assembly



6. Close the hood and ensure the hood does not come into contact with the brackets.

SYSTEM DIAGRAM

FIGURE 7. VSN / Apache AS840, AS1040, AS1240 MY 18+ (P/N 054-2025-002 Rev. A)

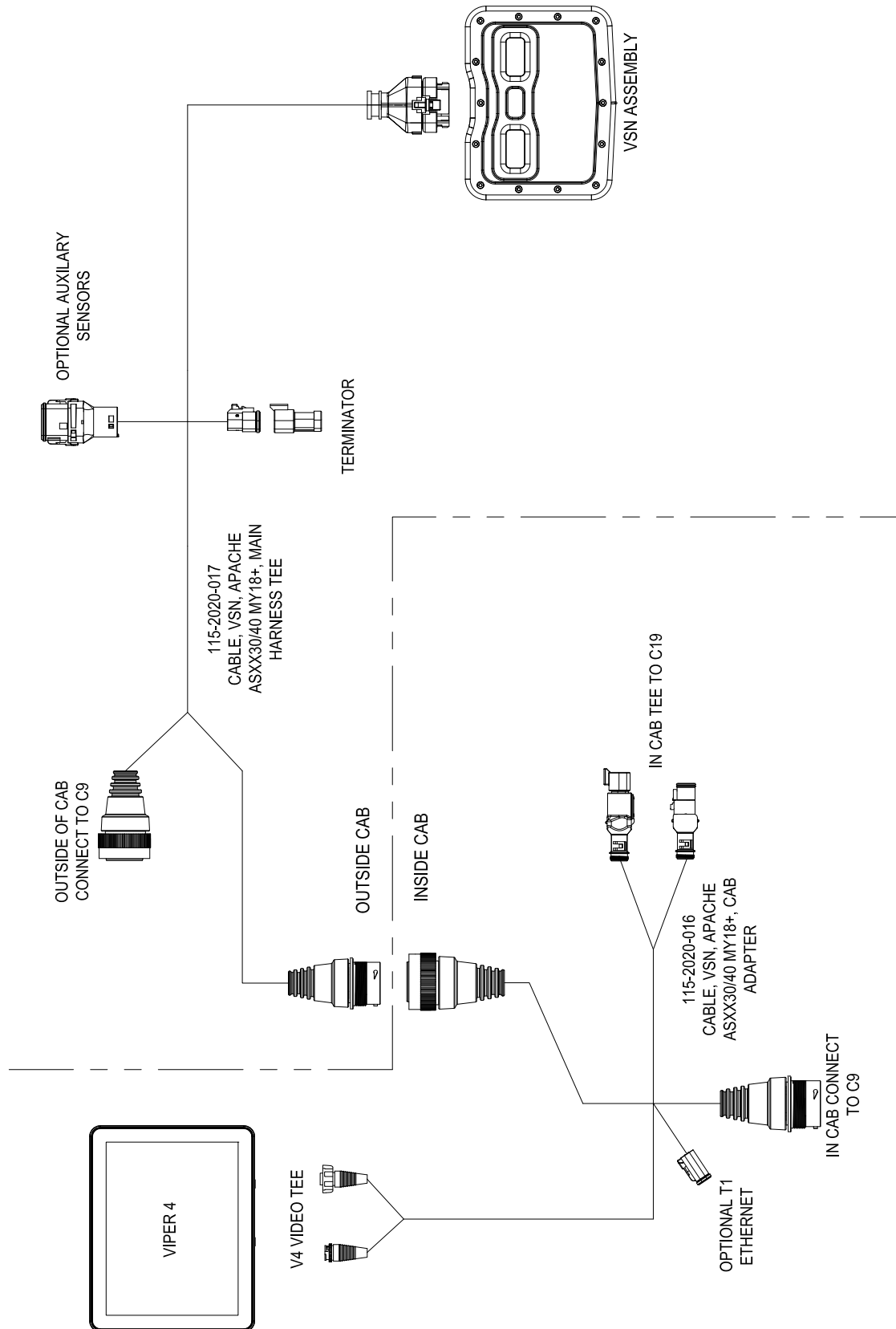

CABLE INSTALLATION

INSIDE OF CAB

1. Identify the VSN Visual Guidance cable (P/N 115-2020-016)
2. Remove the access cover in the cab next to the seat.

FIGURE 8. Access Cover



3. Locate and disconnect the C9 bulkhead.

FIGURE 9. C9 Bulkhead



4. Locate the C19 Slingshot connector.

5. Connect the "TEE AT C19" connector on the cab adapter cable to the C19 Slingshot connection.

NOTE: If needed, connect the other side of the tee to any previous connection to C19.

FIGURE 10. C19 Connection



6. Connect the mating cable to the C9 cable connector disconnected previously.

NOTE: Do not connect the other side of this tee to the connector in the floor at this point.

FIGURE 11. Mating Cable Connected to C9 Cable Connector



7. Remove the nut on the C9 connector in the floorboard.

8. Push the connector out through the bottom of the cab.

FIGURE 12. C9 Connector



9. Route the connector labeled to V4 Video and connect to the back of the field computer.

NOTE: If necessary, use the tee for any video cables already connected.

OUTSIDE OF CAB

1. On the 115-2020-017 Main Harness Tee cable, locate the "TEE AT C9" connection and connect to the bulkhead previously pushed through the floor below the cab of the machine.

FIGURE 13. Main Harness Tee Cable



- The other side of the tee will be pushed up through the hole in the floor and secured using the nut on the connector.

FIGURE 14. Cab Access



- Connect the other side of the 115-2020-016 Raven Cab Cable C9 Tee to the new connector pushed through the floor.

NOTE: This concludes the cab portion of the installation.

4. Put the cover back over the electrical box in the cab.
5. Route the main harness cable under the machine over the drive shaft and along the frame rails up to the VSN bracket.
6. Secure the cable to the bracket after connecting to the VSN.

NOTE: Any slack in the cable should be secured near the frame of the sprayer under the cab.

FIGURE 15. VSN Connection



FIGURE 16. Fully Assembled VSN



OPTIONAL ETHERNET CABLE (FOR USE IN THE EVENT OF WI-FI FAILURE OR RESTRICTION)

OPTIONAL ETHERNET CABLE

1. Connect the blue/green Ethernet cable to the back of the VSN camera.
2. Route the Ethernet cable along the frame and up to the RS1.
3. Connect remaining end to the RS1.

FIGURE 17. RS1 Connection

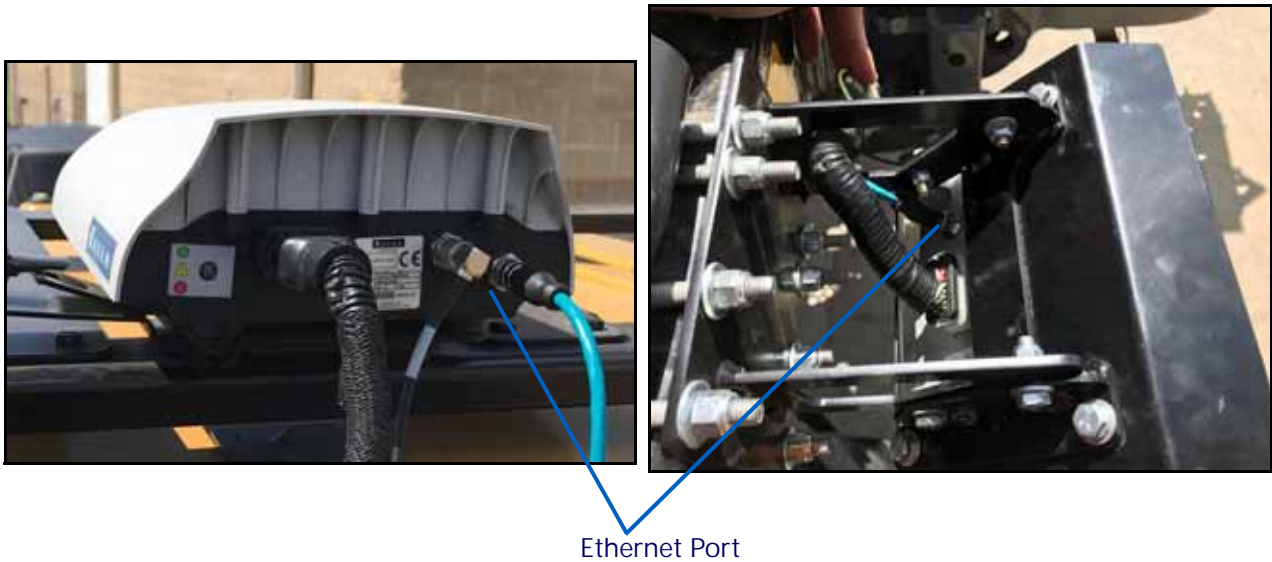

I

Important Safety Information	
Electrical Safety	
General	2
Instructions for Wire Routing	2
Introduction	5
Kit Contents	7
Preparing for Installation	5
Point of Reference	5
Recommendations	5
Updates	6

K

Kit Contents	7
--------------	---

LIMITED WARRANTY

WHAT DOES THIS WARRANTY COVER?

This warranty covers all defects in workmanship or materials in your Raven Applied Technology Division product under normal use, maintenance, and service when used for intended purpose.

HOW LONG IS THE COVERAGE PERIOD?

Raven Applied Technology products are covered by this warranty for 12 months from the date of retail sale. In no case will the Limited Warranty period exceed 24 months from the date the product was issued by Raven Industries Applied Technology Division. This warranty coverage applies only to the original owner and is non-transferable.

HOW CAN I GET SERVICE?

Bring the defective part and proof of purchase to your Raven dealer. If the dealer approves the warranty claim, the dealer will process the claim and send it to Raven Industries for final approval. The freight cost to Raven Industries will be the customer's responsibility. The Return Materials Authorization (RMA) number must appear on the box and all documentation (including proof of purchase) must be included inside the box to be sent to Raven Industries.

WHAT WILL RAVEN INDUSTRIES DO?

Upon confirmation of the warranty claim, Raven Industries will (at our discretion) repair or replace the defective product and pay for the standard return freight, regardless of the inbound shipping method. Expedited freight is available at the customer's expense.

WHAT IS NOT COVERED BY THIS WARRANTY?

Raven Industries will not assume any expense or liability for repairs made outside our facilities without written consent. Raven Industries is not responsible for damage to any associated equipment or products and will not be liable for loss of profit, labor, or other damages. The obligation of this warranty is in lieu of all other warranties, expressed or implied, and no person or organization is authorized to assume any liability for Raven Industries.

Damages caused by normal wear and tear, misuse, abuse, neglect, accident, or improper installation and maintenance are not covered by this warranty.

EXTENDED WARRANTY

WHAT DOES THIS WARRANTY COVER?

This warranty covers all defects in workmanship or materials in your Raven Applied Technology Division product under normal use, maintenance, and service when used for intended purpose.

DO I NEED TO REGISTER MY PRODUCT TO QUALIFY FOR THE EXTENDED WARRANTY?

Yes. Products/systems must be registered within 30 days of retail sale to receive coverage under the Extended Warranty. If the component does not have a serial tag, the kit it came in must be registered instead.

WHERE CAN I REGISTER MY PRODUCT FOR THE EXTENDED WARRANTY?

To register, go online to www.ravenhelp.com and select Product Registration.

HOW LONG IS THE EXTENDED WARRANTY COVERAGE PERIOD?

Raven Applied Technology products that have been registered online are covered for an additional 12 months beyond the Limited Warranty for a total coverage period of 24 months from the date of retail sale. In no case will the Extended Warranty period exceed 36 months from the date the product was issued by Raven Industries Applied Technology division. This Extended Warranty coverage applies only to the original owner and is non-transferable.

HOW CAN I GET SERVICE?

Bring the defective part and proof of purchase to your Raven dealer. If the dealer approves the warranty claim, the dealer will process the claim and send it to Raven Industries for final approval. The freight cost to Raven Industries will be the customer's responsibility. The Return Materials Authorization (RMA) number must appear on the box and all documentation (including proof of purchase) must be included inside the box to be sent to Raven Industries. In addition, the words "Extended Warranty" must appear on the box and all documentation if the failure is between 12 and 24 months from the retail sale.

WHAT WILL RAVEN INDUSTRIES DO?

Upon confirmation of the product's registration for the Extended Warranty and the claim itself, Raven Industries will (at our discretion) repair or replace the defective product and pay for the standard return freight, regardless of the inbound shipping method. Expedited freight is available at the customer's expense.

WHAT IS NOT COVERED BY THE EXTENDED WARRANTY?

Raven Industries will not assume any expense or liability for repairs made outside our facilities without written consent. Raven Industries is not responsible for damage to any associated equipment or products and will not be liable for loss of profit, labor, or other damages. Cables, hoses, software enhancements, and remanufactured items are not covered by this Extended Warranty. The obligation of this warranty is in lieu of all other warranties, expressed or implied, and no person or organization is authorized to assume any liability for Raven Industries.

Damages caused by normal wear and tear, misuse, abuse, neglect, accident, or improper installation and maintenance are not covered by this warranty.