

RS1/HDU Installation Manual for Kubota M6 Series (Non-Steer Ready)

016-5035-057 Rev. A

1/2020

E34372



DISCLAIMER

While every effort has been made to ensure the accuracy of this document, Raven Industries assumes no responsibility for omissions and errors. Nor is any liability assumed for damages resulting from the use of information contained herein.

Raven Industries shall not be responsible or liable for incidental or consequential damages or a loss of anticipated benefits or profits, work stoppage or loss, or impairment of data arising out of the use, or inability to use, this system or any of its components. Raven Industries shall not be held responsible for any modifications or repairs made outside our facilities, nor damages resulting from inadequate maintenance of this system.

As with all wireless and satellite signals, several factors may affect the availability and accuracy of wireless and satellite navigation and correction services (e.g. GPS, GNSS, SBAS, etc.). Therefore, Raven Industries cannot guarantee the accuracy, integrity, continuity, or availability of these services and cannot guarantee the ability to use Raven systems, or products used as components of systems, which rely upon the reception of these signals or availability of these services. Raven Industries accepts no responsibility for the use of any of these signals or services for other than the stated purpose.

Chapter 1	Important Safety Information.....	1
Hydraulic		2
General		2
Instructions for Hose Routing		2
Electrical		3
General		3
Instructions for Wire Routing		3
Chapter 2	Introduction.....	7
Introduction		7
Preparing for Installation		7
Recommendations		7
Tools Needed		8
Point of Reference		8
Updates		8
Kit Contents		8
Chapter 3	Hydraulic System Installation.....	13
Install Fittings in the Hydraulic Steering Valve		14
Install Fittings in the Dual POCl Valve		15
Mount the Hydraulic Steering and Dual POCl Valves		16
Install the Pressure, Excess Flow, and Tank Lines		21
Hydraulic Diagram		26
Chapter 4	Cab Component and Sensor Installation.....	27
Install Wheel Angle Sensor		27
Wheel Angle Sensor Brackets		27
Mount HDU ECU		30
Connect The RS1 HDU Cable		32
In Cab		32
Mount Foot Switch		34
Assemble and Mount the Master Engage Switch		35
Outside of Cab		35
Mount the RS1		38
Chapter 5	Startup Procedures	41
Verify the System Installation		41

CHAPTER

1

IMPORTANT SAFETY INFORMATION

NOTICE

Read this manual and the operation and safety instructions included with your implement and/or controller carefully before installing the RS1 system.

- Follow all safety information presented within this manual.
- If you require assistance with any portion of the installation or service of your Raven equipment, contact your local Raven dealer for support.
- Follow all safety labels affixed to the RS1 system components. Be sure to keep safety labels in good condition and replace any missing or damaged labels. To obtain replacements for missing or damaged safety labels, contact your local Raven dealer.

When operating the machine after installing RS1, observe the following safety measures:

- Be alert and aware of surroundings.
- Do not operate RS1 or any agricultural equipment while under the influence of alcohol or an illegal substance.
- Remain in the operator's position or a safe working distance away from the booms at all times when RS1 is engaged.
- Disable RS1 when exiting from the operator's seat and machine.
- Do not drive the machine with RS1 enabled on any public road.
- Determine and remain a safe working distance from other individuals. The operator is responsible for disabling RS1 when the safe working distance has diminished.
- Ensure RS1 is disabled prior to starting any maintenance work on RS1 or the machine.



WARNING

- When starting the machine for the first time after installing RS1, be sure that all persons stand clear in case a hose has not been properly tightened.

CAUTION

HYDRAULIC

GENERAL

- Raven Industries recommends that appropriate protective equipment be worn at all times when working on the hydraulic system.
- Never attempt to open or work on a hydraulic system with the equipment running. Care should always be taken when opening a system that has been previously pressurized.
- When disconnecting the hydraulic hoses or purging is required, be aware that the hydraulic fluid may be extremely hot and under high pressure. Caution must be exercised.
- Any work performed on the hydraulic system must be done in accordance with the machine manufacturer's approved maintenance instructions.
- When installing RS1 hydraulics or performing diagnostics, maintenance, or routine service, ensure that precautions are taken to prevent any foreign material or contaminants from being introduced into the hydraulic system. Objects or materials that are able to bypass the hydraulic filtration system will reduce performance and possibly damage the RS1 hydraulic valve.

INSTRUCTIONS FOR HOSE ROUTING

The word "hose" is used to mean all flexible fluid carrying components. Follow existing hoses as much as possible and use these guidelines:

Hoses should not contact or be attached to:

- Components with high vibration forces
- Components carrying hot fluids beyond component specifications

Avoid contact with any sharp edge or abrading surfaces such as, but not limited to:

- Sheared or flame cut edges
- Edges of machined surfaces
- Fastener threads or cap screw heads
- Ends of adjustable hose clamps

Routing should not allow hoses to:

- Hang below the unit
- Have the potential to become damaged due to exposure to the exterior environment. (i.e. tree limbs, debris, attachments)
- Be placed in areas of or in contact with machine components which develop temperatures higher than the temperature rating of hose components
- Hoses should be protected or shielded if it needs to route near hot temperatures beyond hose component specifications

Hoses should not have sharp bends

Allow sufficient clearance from machine component operational zones such as:

- Drive shafts, universal joints and hitches (i.e. 3-point hitch)
- Pulleys, gears, sprockets
- Deflection and backlash of belts and chains
- Adjustment zones of adjustable brackets
- Changes of position in steering and suspension systems
- Moving linkages, cylinders, articulation joints, attachments
- Ground engaging components

For hose sections that move during machine operation:

- Allow sufficient length for free movement without interference to prevent: pulling, pinching, catching or rubbing, especially in articulation and pivot points
- Clamp hoses securely to force controlled movement to occur in the desired hose section
- Avoid sharp twisting or flexing of hoses in short distances

Protect hoses from:

- Foreign objects such as rocks that may fall or be thrown by the unit
- Buildup of dirt, mud, snow, ice, submersion in water and oil
- Tree limbs, brush and debris
- Damage where service personnel or operators might step or use as a grab bar
- Damage when passing through metal structures
- High pressure wash

ELECTRICAL

GENERAL

- Always verify that the power leads are connected to the correct polarity as marked. Reversing the power leads could cause severe damage to the equipment.
- Ensure that the power cable is the last cable to be connected.
- A minimum of 12 VDC is required for system operation with a maximum of 15 VDC.

INSTRUCTIONS FOR WIRE ROUTING

The word "harness" is used to mean all electrical leads and cables, bundled and unbundled. When installing harness, secure it at least every 30 cm (12in) to the frame. Follow existing harness as much as possible and use these guidelines:

Harness should not contact or be attached to:

- Lines and hoses with high vibration forces or pressure spikes
- Lines and hoses carrying hot fluids beyond harness component specifications

Avoid contact with any sharp edge or abrading surfaces such as, but not limited to:

- Sheared or flame cut edges
- Edges of machined surfaces
- Fastener threads or cap screw heads

- Ends of adjustable hose clamps
- Wire exiting conduit without protection, either ends or side of conduit
- Hose and tube fittings

Routing should not allow harnesses to:

- Hang below the unit
- Have the potential to become damaged due to exposure to the exterior environment. (i.e. tree limbs, debris, attachments)
- Be placed in areas of or in contact with machine components which develop temperatures higher than the temperature rating of harness components
- Wiring should be protected or shielded if it needs to route near hot temperatures beyond harness component specifications

Harnessing should not have sharp bends

Allow sufficient clearance from machine component operational zones such as:

- Drive shafts, universal joints and hitches (i.e. 3-point hitch)
- Pulleys, gears, sprockets
- Deflection and backlash of belts and chains
- Adjustment zones of adjustable brackets
- Changes of position in steering and suspension systems
- Moving linkages, cylinders, articulation joints, attachments
- Ground engaging components

For harness sections that move during machine operation:

- Allow sufficient length for free movement without interference to prevent: pulling, pinching, catching or rubbing, especially in articulation and pivot points
- Clamp harnesses securely to force controlled movement to occur in the desired harness section
- Avoid sharp twisting or flexing of harnesses in short distances
- Connectors and splices should not be located in harness sections that move

Protect harnesses from:

- Foreign objects such as rocks that may fall or be thrown by the unit
- Buildup of dirt, mud, snow, ice, submersion in water and oil
- Tree limbs, brush and debris
- Damage where service personnel or operators might step or use as a grab bar
- Damage when passing through metal structures

IMPORTANT:

- Avoid directly spraying electrical components and connections with high pressure water. High pressure water sprays can penetrate seals and cause electrical components to corrode or otherwise become damaged. When performing maintenance:
 - Inspect all electrical components and connections for damage or corrosion. Repair or replace components, connections, or cable as necessary.
 - Ensure connections are clean, dry, and not damaged. Repair or replace components, connections, or cable as necessary.
 - Clean components or connections using low pressure water, pressurized air, or an aerosol electrical component cleaning agent.

- Remove visible surface water from components, connections, or seals using pressurized air or an aerosol electrical component cleaning agent. allow components to dry completely before reconnecting cables.

INTRODUCTION

Thank you for selecting the Raven RS1 steering system. The RS1 system is designed to provide hands free steering of agricultural equipment using Global Navigation Satellite System (GNSS) position data.

This manual applies to the following machines:

MAKE: Kubota
MODEL: M6-131, M6-141
YEAR: 2019 & Newer

PREPARING FOR INSTALLATION

Before installing RS1, park the machine where the ground is level, clean, and dry. Leave the machine turned off for the duration of the installation process.

During the installation process, follow good safety practices. Be sure to carefully read the instructions in this manual as you complete the installation process.

RECOMMENDATIONS

Raven Industries recommends the following best practices before installing or operating the RS1 system for the first time, at the start of the season, or when moving the RS1 system to another machine:

- Ensure the hydraulic filters have been recently changed and there are no issues with the hydraulic system (e.g., pump issues, faulty hydraulic motors, fine metal deposits in the hydraulic hoses, etc.).
- Operate each of the hydraulic functions on the machine (i.e., tilt, fold, center rack, tongue extension, turning the steering wheel to the left and right steering locks, or other hydraulic valve functions) three times to ensure the hydraulic valve is using fresh oil and debris is flushed from the hydraulic hoses, valves, and filters.

Raven Industries recommends the following best practices when installing the RS1 system.

- Use part numbers to identify the parts.
- Do not remove the plastic wrap from a part until it is necessary for installation.
- Do not remove plastic caps from a part until it is necessary for installation.

TOOLS NEEDED

The following tools are recommended for installation of the RS1 system:

- SAE and metric wrenches and sockets
- Cable ties
- Set of tools

POINT OF REFERENCE

The instructions in this manual assume that you are standing behind the machine, looking toward the cab.

UPDATES

Software and manual updates are available on the Raven Applied Technology website:

<http://www.ravenhelp.com>

At Raven Industries, we strive to make your experience with our products as rewarding as possible. One way to improve this experience is to provide us with feedback on this manual.

Your feedback will help shape the future of our product documentation and the overall service we provide. We appreciate the opportunity to see ourselves as our customers see us and are eager to gather ideas on how we have been helping or how we can do better.

To serve you best, please send an email with the following information to

techwriting@ravenind.com

- RS1/HDU Installation Manual for Kubota M6 Series (Non-Steer Ready)
- 016-5035-057 Rev. A
- Any comments or feedback (include chapter or page numbers if applicable).
- Let us know how long have you been using this or other Raven products.

We will not share your email or any information you provide with anyone else. Your feedback is valued and extremely important to us.

Thank you for your time.

KIT CONTENTS

This section contains a list of the components that are included in the RS1 kit. Before beginning the RS1 installation, compare the items in the RS1 kit with the components on this list. If you have questions about the kit, contact your local Raven dealer.

FIGURE 1. RS1 Installation Kit for Kubota M6 (P/N 117-5035-057 Rev. A)

QTY	PART #	DESCRIPTION
1	053-0159-197	BOX, SHIPPING
1	116-0159-842	WELDMENT, HYDRAULIC VALVE, KUBOTA M6 MY19
1	116-0159-843	WELDMENT, WAS ARM, KUBOTA M6 MY19
1	107-0172-657	BRACKET, TC1/HDU MOUNT, KUBOTA M6 MY19
1	107-0172-658	BRACKET, HYDRAULIC VALVE HOLD DOWN, KUBOTA M6 MY
1	107-0172-660	BRACKET, WAS FRAME, KUBOTA M6 MY19
1	107-0172-659	BRACKET, WAS WHEEL, KUBOTA M6 MY19
1	063-0181-024	SENSOR ASSEMBLY, ROTARY WHEEL ANGLE
1	422-0000-086	TRANSDUCER, PRESSURE, 0-3000 PSI
1	115-4010-171	CABLE, RS1, KUBOTA M6 TRACTOR
1	115-4010-172	CABLE, RS1, VALVE, KUBOTA M6 TRACTOR
1	115-4010-028	CABLE, CAB SWITCH
1	063-0173-961	ASSEMBLY, SWITCH, MASTER RS1
1	063-0173-887	NODE, HDU
1	117-5001-051	KIT, ROOF, RS1 GENERIC MAGNET
1	334-0003-090	VALVE, HYDRAULIC, SMARTRAX, OPEN CENTER
1	334-0003-099	VALVE, HYD DUAL POCI
1	063-0172-470	ENGAGE FOOT SWITCH
1	117-0199-010	KIT, HYDRAULIC, STEERING, KUBOTA M6 MY19+
		CONT..

FIGURE 2. RS1 Installation Kit for Kubota M6 (P/N 117-5035-057 Rev. A)

QTY	PART #	DESCRIPTION
		PREV..
1	053-0159-015	ENVELOPE, PLASTIC
2	311-5051-177N	M8X1.25X15MM BOLT
2	311-0050-086	1/4-20X2.5 IN BOLT
4	311-4046-080N	M10X1.25X20MM BOLT
4	311-4046-081N	M10X1.25X25MM BOLT
3	311-0052-078	5/16-18X0.75IN
2	311-0052-087	5/16-18X3IN BOLT
1	311-0050-076	1/4-20X 1/2" BOLT
1	107-0172-434	ROD, THREADED, M6X1.0X9.45 IN
2	313-2300-310	1/4 INCH WASHER
4	313-6001-016N	M10 LOCK WASHER
4	313-6000-016N	M10 WASHERS
9	313-2300-012	5/16 WASHERS, 0.1IN THICK
4	313-6000-010N	M6 WASHERS
2	312-4000-057	1/4-20 LOCK NUT
2	312-1001-035	5/16-18 NUTS
2	312-6000-017K	NUT, HEX, M6
2	312-6001-017K	NUT, LOCK, NYLON INSERT, M6
2	325-0000-031	BEARING, ROD END
2	327-1880-895	1/4 ID .895IN LONG SPACER
2	327-1990-375	M10 ID .375 WIDE SPACER
1	118-0159-056	HOUSING, ROCKER SWITCH, BASE
1	118-0159-057	HOUSING, ROCKER SWITCH, COVER
4	311-0008-027	SCREW 4-40 UNC X 1/2" PHILLIPS

FIGURE 3. Hydraulic Steering Kit for Kubota M6 Series (P/N 117-0199-010 Rev. B)

QTY	PART #	DESCRIPTION
1	333-0012-584	-6 BSPP RUN TEE
5	333-0012-233	-10 ORING (M) TO -6 FF (M)
5	333-0012-065	-6 FF ELBOW (M TO F)
2	333-0012-090	-6 FF 45 (M TO F)
6	333-0012-199	-8 ORING (M) TO -6 FF(M) **REMOVED**
4	333-0012-051	-4 ORING PLUGS (M)
1	333-0012-586	-6 BSPP (F) 90 (M TO F)
1	333-0012-057	-4 ORING (M) TO -4 JIC STRAIGHT (M)
1	333-0012-280	-4 JIC 45 (M TO F)

HYDRAULIC HOSES

	PART # / LABEL	END 1	SIZE	END2	LENGTH
1	214-1001-204	-6 90 FF (F)	-6	-6 BSPP (F)	45"
1	214-1001-205	-6 90 FF (F)	-6	-6 BSPP (F)	30"
1	214-1001-206	-6 90 FF (F)	-6	-6 BSPP (M)	30"
2	214-1001-207	-6 FF 45 (F)	-4	-4 19 BSPP (F)	46"
2	214-1001-208	-6 FF 45 (F)	-4	-4 19 BSPP (M)	36"
2	214-1001-209	-6 FF (F)	-4	-6 FF 90 (F)	22"
1	214-1001-210	-4 JIC (F)	-4	-4 ORING (F)	12"

CHAPTER

3

HYDRAULIC SYSTEM INSTALLATION



WARNING

Hydraulics are under pressure. Care should always be taken with a system that has been pressurized.

Before beginning the RS1 hydraulic installation, turn off the machine and relieve pressure by turning the steering wheel left and right.

Never work on a hot machine. Always allow it to cool before performing diagnostics, maintenance, or routine service.

When disconnecting or purging hydraulic hoses, be aware that the hydraulic fluid within the system may be extremely hot and under high pressure.

Tampering with hydraulic valves may cause serious injury or death, and will void the warranty.



CAUTION

When installing RS1 hydraulics or performing diagnostics, maintenance, or routine service, ensure precautions are taken to prevent any foreign material from being introduced into the hydraulic system.

Objects or materials that are able to bypass the hydraulic filtration system will reduce performance and possibly damage the RS1 hydraulic valve.



NOTICE

The appearance of the RS1 hydraulic valve may vary slightly from the images contained in this manual. However, the fittings, hose connections, and cable connections remain the same.

INSTALL FITTINGS IN THE HYDRAULIC STEERING VALVE

Before mounting the hydraulic steering valve (P/N 334-0003-090) on the machine, install the proper fittings in the valve. This prepares the valve for installation and simplifies the hose connection process later in the procedure. Refer to the following table to install the fittings in the appropriate ports of the hydraulic steering valve.

FIGURE 1. Fittings Installed in Hydraulic Steering Valve

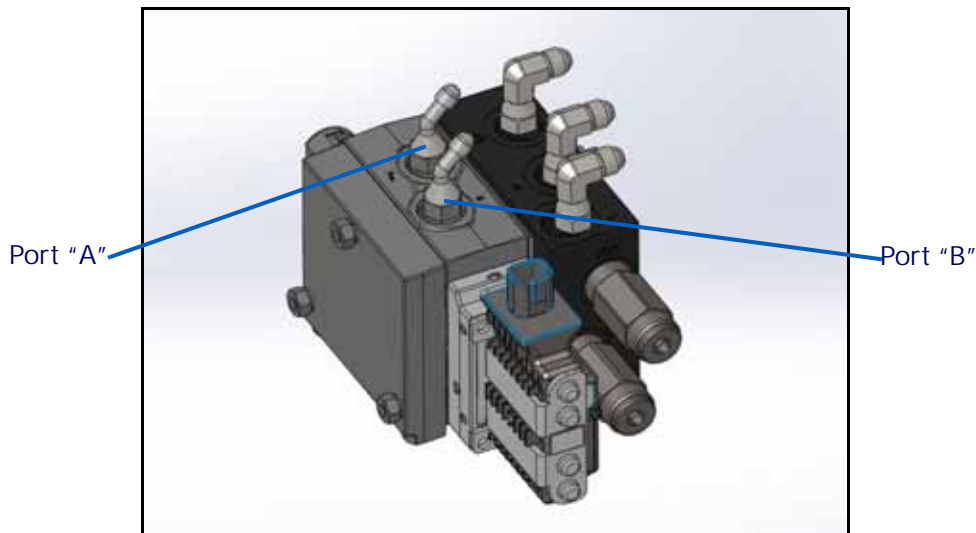

TABLE 1. Steering Valve Fitting Installation

Fitting	Part Number	Port
Fitting - -10 SAE O-Ring (M) to -6 ORFS (M)	333-0012-233	A, B, P, T, EF
Fitting - -6 ORFS 90 Elbow	333-0012-065	P, T, EF
Fitting - -6 ORFS 45	333-0012-090	A, B

INSTALL FITTINGS IN THE DUAL POCI VALVE

Before mounting the dual POCI valve (P/N 334-0003-099) on the machine, install the proper fittings in the valve. This prepares the valve for installation and simplifies the hose connection process later in the procedure. Refer to Figure 2 and the table below to install fittings on the dual POCI valve.

FIGURE 2. Fittings Installed on Dual POCI Valve

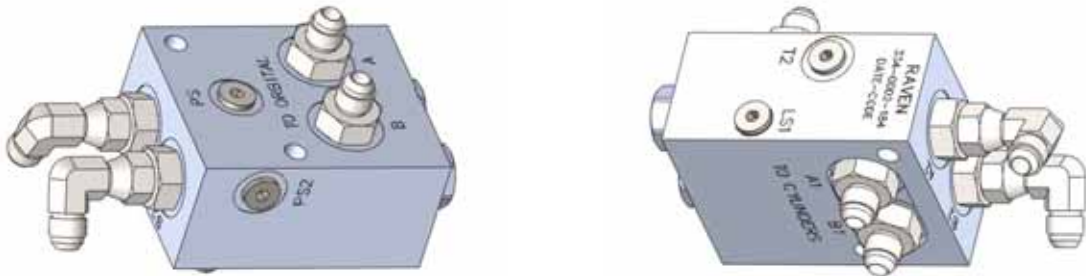

TABLE 2. Dual POCI Valve Fitting Installation

Fitting	Part Number	Port
Fitting - -8 SAE O-Ring (M) to -6 ORFS (M) Straight Adapter	333-0012-199	A, B, A1, B1, A2, B2
Fitting - -6 ORFS 90° Swivel Elbow	333-0012-065	A2, B2
Fitting - -4 SAE O-Ring Plug	333-0012-051	PS2, T2, LS1, PS



MOUNT THE HYDRAULIC STEERING AND DUAL POCI VALVES

1. Remove the right side step for easier access to the valve mounting location.

FIGURE 3. Remove Side Step



2. If the tractor is equipped with a loader, remove the gray shield around the loader hydraulic valve.

FIGURE 4. Remove Hydraulic Valve Shield



3. Remove the gray shield behind the loader valve bracket.

FIGURE 5. Remove Shield

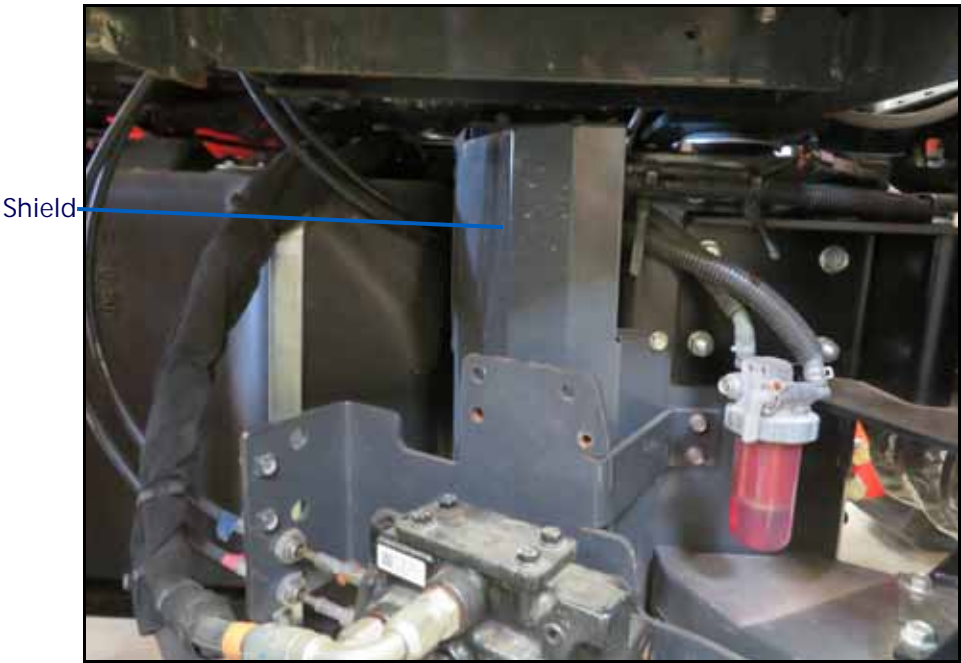

4. Remove the bolts that secure the black computer box as seen in figure 6.

FIGURE 6. Computer Box



5. Carefully lower the computer box so it does not block the two hydraulic hoses, one with yellow tape, and one with blue tape.

FIGURE 7. Hydraulic Hoses



6. Remove the shield facing the front of the tractor under the exhaust by removing the three black bolts as seen in figure 8.

FIGURE 8. Remove Shield



7. Mount the hydraulic valve (P/N 334-0003-090) to the valve bracket (P/N 116-0159-842) using the three 5/16" x 3/4" bolts and three 5/16" washers under each head of the bolts.
8. Mount the DPOCI valve (P/N 334-0003-099) to the valve bracket (P/N 116-0159-842) using two 5/16" x 3" bolts and nuts.

9. Connect A on the steering valve to A1 on the DPOCI and B on the steering valve to B1 on the DPOCI using hoses (P/N 214-1001-209), and with elbow ends of the hoses on the DPOCI as shown in figure 9.

FIGURE 9. DPOCI Valve to Valve Bracket



10. Attach the hoses to the P, T, and EF ports with the 90 degree end connecting to the elbow on the steering valve.
11. Connect the P/N 214-1001-204 hose to the pressure port.
12. Connect the P/N 214-1001-205 hose to the tank port.
13. Connect the P/N 214-1001-206 hose to the EF port.
14. Connect the P/N 214-1001-210 to the steering valve in the PS port on the steering valve.
15. Connect the pressure transducer (P/N 422-0000-086) to the open end of the hose.
16. Connect the P/N 214-1001-207 hose to A and B on the DPOCI.
17. Connect the P/N 214-1001-208 to A2 and B2 on the DPOCI.

FIGURE 10. Fully Connected DPOCI



- Carefully slide the bracket with the mounted valves around the exhaust to place it on the bracket, placing it where the shield was removed in step 6, with the bracket facing the front of the tractor, as seen in figure 10.

FIGURE 11. Placed Bracket



- Using the included M10x.375" spacers, M10 washers, and M10x25mm bolts, attach the valve bracket to the tractor by spacing it away from the mounting surface with the spacers.
- Remove the two rightmost bolts under the tractor from the row of three bolts, as seen in figure 11.

FIGURE 12. Three Bolts

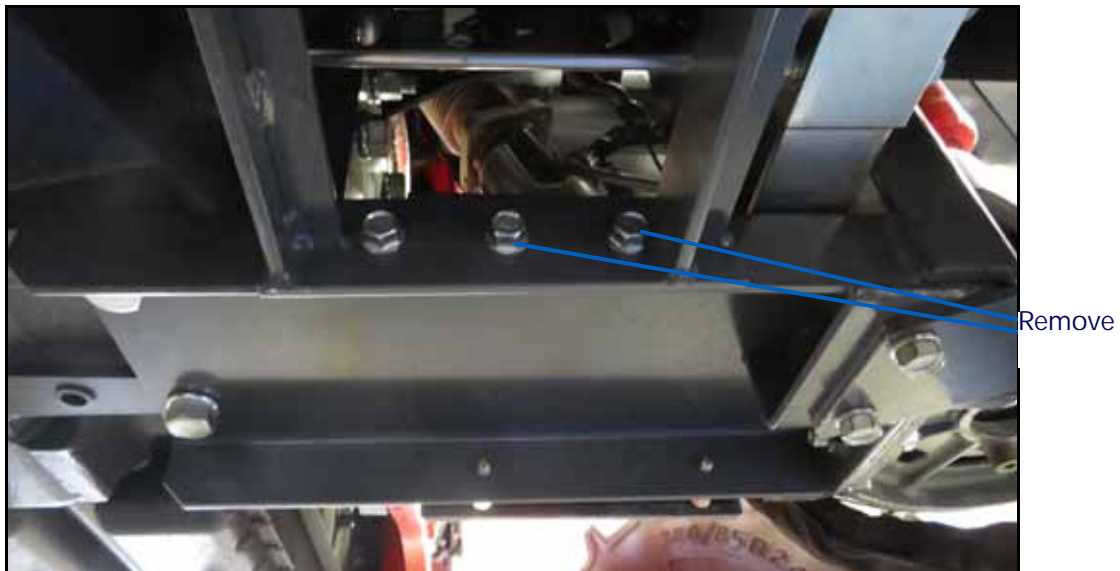

- Place the bracket (P/N 107-0172-658) so that it is holding down on the valve bracket above.

22. Secure using the supplied M10x25mm bolts and washers.

FIGURE 13. Secured Valve

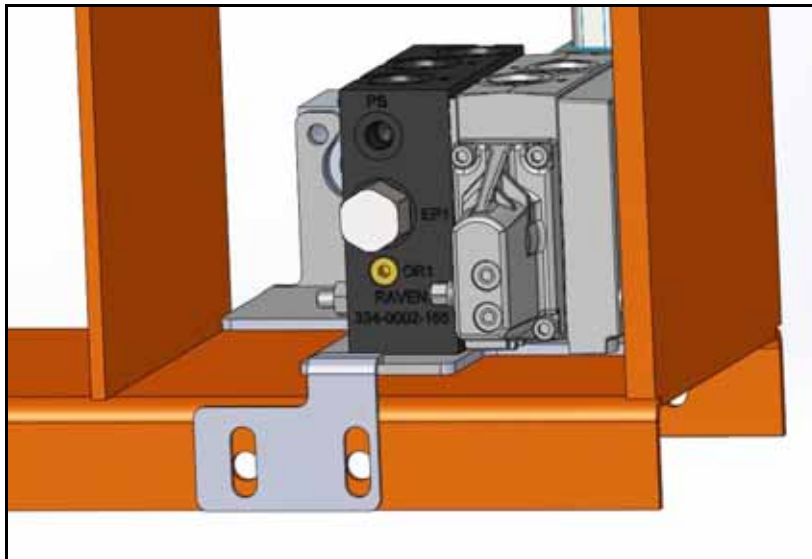

INSTALL THE PRESSURE, EXCESS FLOW, AND TANK LINES

NOTE: The hose with blue tape is the pressure hose, and the hose with yellow tape is the tank hose. It is recommended to label these hoses to avoid confusing them with each other.

FIGURE 14. Pressure and Tank Hoses



1. Remove the pressure hose and the tank hose from their connections.
2. Connect the supplied run tee to the tank line port.
3. Reconnect the yellow tank hose.

FIGURE 15. Tank Hose Connected with Run Tee



4. Connect the BSPP elbow to the open tank tee port.

FIGURE 16. BSPP Elbow Connected to Tank Tee Port



5. Route the tank hose from the steering valve to the open port on the elbow installed on the T port (P/N 214-1001-205).
6. Connect the pressure port on the steering valve and the P port on the tractor with the hose (P/N 214-1001-204).

FIGURE 17. Pressure Port Connected to P Port



- 7. Connect the Excess Flow port on the steering valve to the hose with blue tape using the hose (P/N 214-1001-206).

FIGURE 18. Connected Excess Flow Port



8. Locate the red and green lines near the pressure and tank hoses.

FIGURE 19. Red and Green Lines

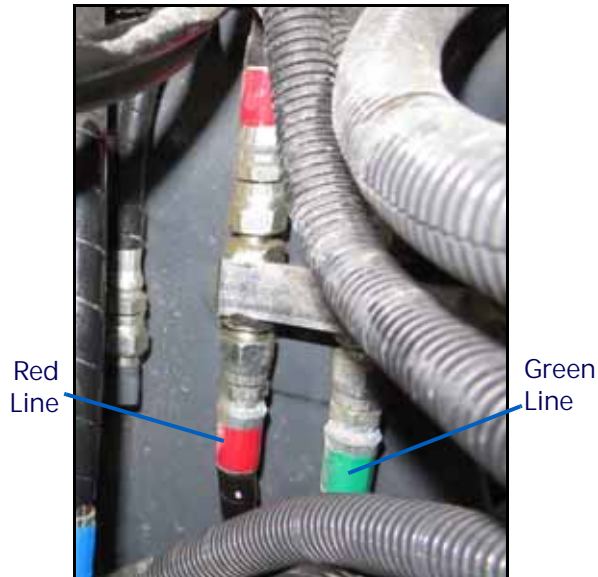

9. Remove both lines at the bottom.

FIGURE 20. Removed Red and Green Lines



10. From the DPOCI, connect the A2 hose (P/N 214-1001-208) to the green tape hose.
11. From the DPOCI, connect the B2 hose (P/N 214-1001-208) to the red tape hose.

FIGURE 21. A2 and B2 Connections



- 12. Connect the A hose (P/N 214-1001-207) to the green connection.
- 13. Connect the B hose (P/N 214-1001-207) to the red connection.

FIGURE 22. Completed Connections



- 14. Reinstall the black computer box, gray shield, loader valve guard (if removed), and reinstall ladder.

HYDRAULIC DIAGRAM

FIGURE 23. Hydraulic Steering Installation Diagram

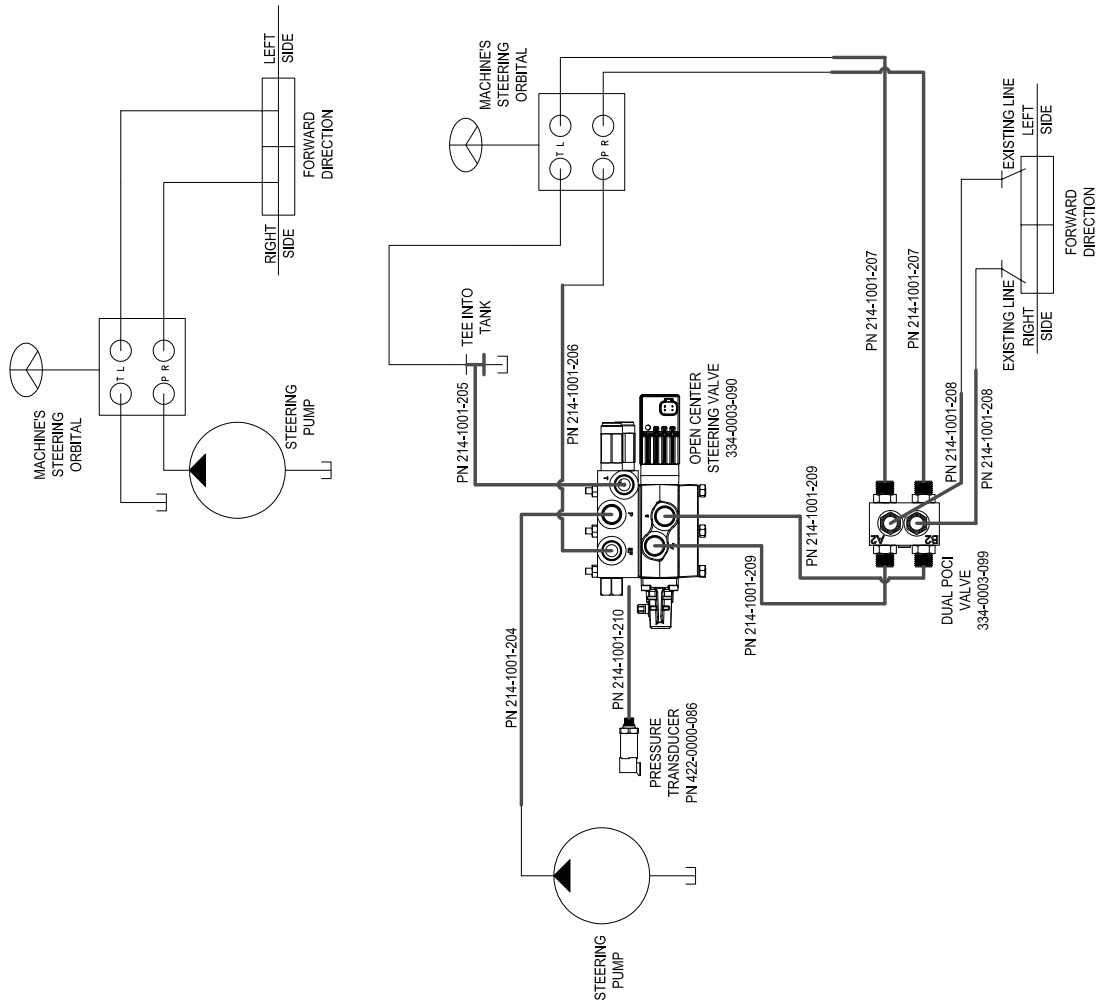

CHAPTER

4

CAB COMPONENT AND SENSOR INSTALLATION

INSTALL WHEEL ANGLE SENSOR

WHEEL ANGLE SENSOR BRACKETS

1. Remove the two bolts that secure the protective wire tube to the axle and the two bolts shown on the axle.

FIGURE 1. Remove Bolts



2. Attach the wheel angle sensor to the WAS Frame bracket (P/N 107-0172-660) with the included bolts supplied in the WAS kit (P/N) 063-0181-024).
3. Attach the sensor arm (P/N 116-0159-843) to the wheel angle sensor using a 1/4"x1/2" bolt that will tighten against the flat surface on the sensor.

FIGURE 2. Sensor Arm and Wheel Angle Sensor



4. Attach the other bracket (P/N 107-0172-659) to the wheel hub using 2 M10x1.25x20mm bolts with the M10 lock washer.

FIGURE 3. Bracket Attached to Wheel Hub



5. Attach the wheel angle sensor assembly from the last step to the axle and replace the protective tube unbolted before the M10x1.25x20mm bolts and M10 lock washers.

FIGURE 4. Wheel Angle Sensor Attached to Axle



6. Assemble the linkage.

NOTE: The linkage is assembled by using the threaded rod (P/N 325-0000-031) M6 nuts, M6 washers, and nylon M6 lock nuts.

7. Thread the M6 nuts onto the threaded rod.

8. Thread the tie rod ends until they stop.

NOTE: Ensure the two tie rod ends are orientated in the same direction.

Ensure nuts are tightened against the ends.

9. Place washers on each side of the brackets and the nylon lock nuts.

10. Secure the assembly to the brackets.

FIGURE 5. Assembly Secured to Brackets



MOUNT HDU ECU

1. Locate the storage cubby behind the seat in the cab.
2. Remove the two bolts securing the storage cubby.

FIGURE 6. Storage Cubby



3. Mount the HDU to the bracket (P/N 107-0172-657) using the 1/4x1.5" bolts and nuts.

NOTE: Mount the HDU with the white sticker facing up and the connectors facing the right.

FIGURE 7. Mounted HDU

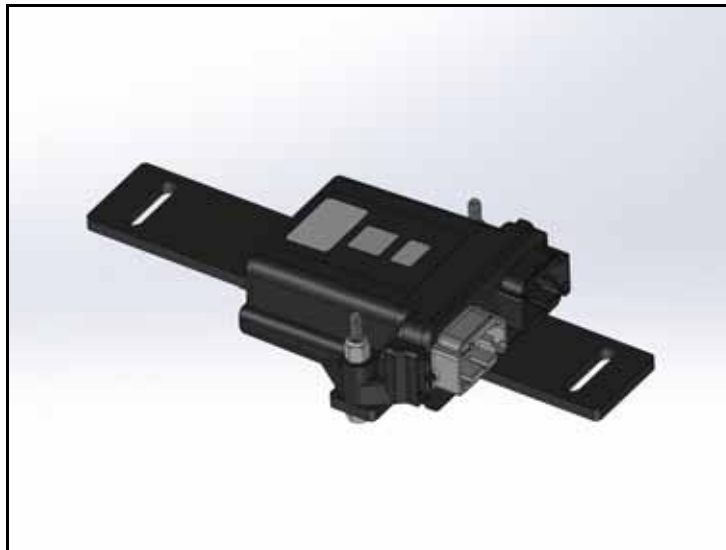

4. Attach the bracket to the cab using the M10x1.25x20mm bolts.

FIGURE 8. Attached Bracket



CONNECT THE RS1 HDU CABLE

IN CAB

1. Connect the two 12-pin connectors labeled "HDU" on the RS1 cable (P/N) 115-4010-171 into the HDU.

FIGURE 9. RS1 Cable Connection



2. Locate the universal power connection in the right rear of the cab. Connect the mating connector labeled PWR.

FIGURE 10. Power Terminal Location



3. Locate the round connector labeled Field Computer. Connect to appropriate field computer harness.

FIGURE 11. Switched Power and Field Computer Connections



4. Locate the 8-pin connector labeled CAB SWITCH HARNESS on the Tractor Harness cable (P/N 115-4010-171) previously installed.

FIGURE 12. Cab Switch Harness Connection



5. Connect mating connector on HDU Cab Switch Breakout Cable (P/N 115-4010-028) to the CAB SWITCH HARNESS connection.

MOUNT FOOT SWITCH

1. Route the Engage Foot Switch (P/N 063-0172-470) to the mating connector on the Breakout Cable (P/N 115-4010-028).

FIGURE 13. Resume Foot Switch Connection



2. Select a suitable location for the foot switch (P/N 063-0172-470) to be mounted.

NOTE: The foot switch should be installed in a location where the operator has easy access to it and is able to fully press the pedal.

3. Using the holes in the foot switch as a template, drill holes in the floor of the cab.
4. Secure the foot switch to the floor by installing the supplied screws in each of the mounting holes.

ASSEMBLE AND MOUNT THE MASTER ENGAGE SWITCH

1. Secure the Master Switch (P/N 063-0173-961) between the two switch enclosure halves (P/N 118-0159-056 and 118-0159-057) and locate an appropriate location to mount the master switch assembly.
2. Connect the supplied master switch (P/N 063-0173-961) to the mating connector on the Breakout Cable (P/N 115-4010-028).

FIGURE 14. Master Switch Connection



OUTSIDE OF CAB

1. Locate the 12-pin and 4-pin connectors on the Valve Harness Cable (P/N 115-4010-172) and route them into the cab through the cab access port at the bottom, right corner of the rear window.
2. Connect the Valve Harness Cable (P/N 115-4010-172) to the mating connectors on the RS1 Cable (P/N 115-4010-171) inside the machine cab.

FIGURE 15. Cab Access Point



3. Route the 4-pin connector labeled VALVE to the steering valve mounted under the exhaust on the right side of the tractor.
4. Connect the VALVE connector to the mating port on the steering valve.

IMPORTANT: Ensure there are no cables or hydraulic lines close to or in contact with the exhaust pipe.

FIGURE 16. Valve Electrical Connection



5. Connect the 3-pin connector labeled PSI to the pressure transducer on the steering valve hose.

FIGURE 17. Pressure Transducer Connection



NOTE: A hose will hang in between the steering valve and the sensor to bring the sensor down and away from where the computer is mounted.

6. Route the cable on the wheel angle sensor along the axle to the right side of the tractor and up along the hydraulic hoses back towards the steering valve installed.

NOTE: Be sure to allow slack in the cable when tying the cable down for the front axle to articulate over terrain and to avoid pinch points.

FIGURE 18. Wheel Angle Sensor Cable Routing



7. Connect the wheel angle sensor cable to the valve cable (P/N 115-4010-172) labeled "WAS".
8. Reinstall the bolts that secured the computer.
9. Reinstall any removed shields.
10. Reinstall the ladder.

MOUNT THE RS1

1. Using the 1/4-20 bolts included in the 117-5001-051 kit, connect the magnets to the RS1 as shown below.

FIGURE 19. Magnets Connected to RS1

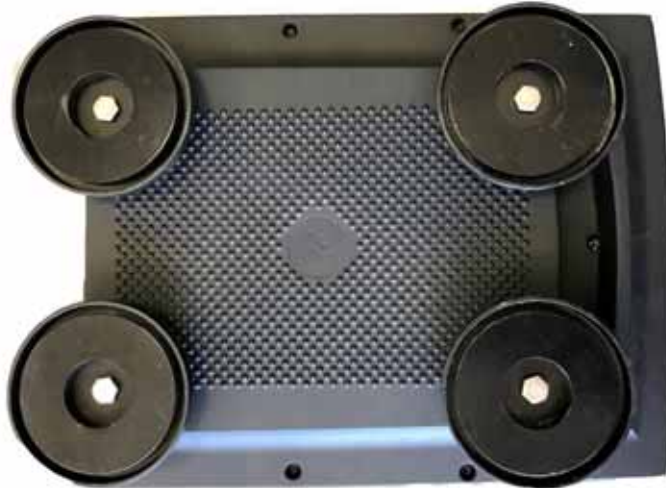

2. Center the plate on the cab roof and apply the tape to secure the plate to the cab roof.

FIGURE 20. Roof Bracket Secured to Roof



- Using the magnets to secure in place, mount the RS1 unit to the plate.

FIGURE 21. RS1 Mounted onto Plate



NOTE: Ensure the RS1 is centered on the plate and is facing the front of the cab.

- Route the two connectors labeled "RS1" up the corner pillar of the cab.
- Connect the 12-pin connector to the RS1 unit on the roof.

FIGURE 22. Valve Harness Wiring Diagram (P/N 054-5035-005 Rev. A)

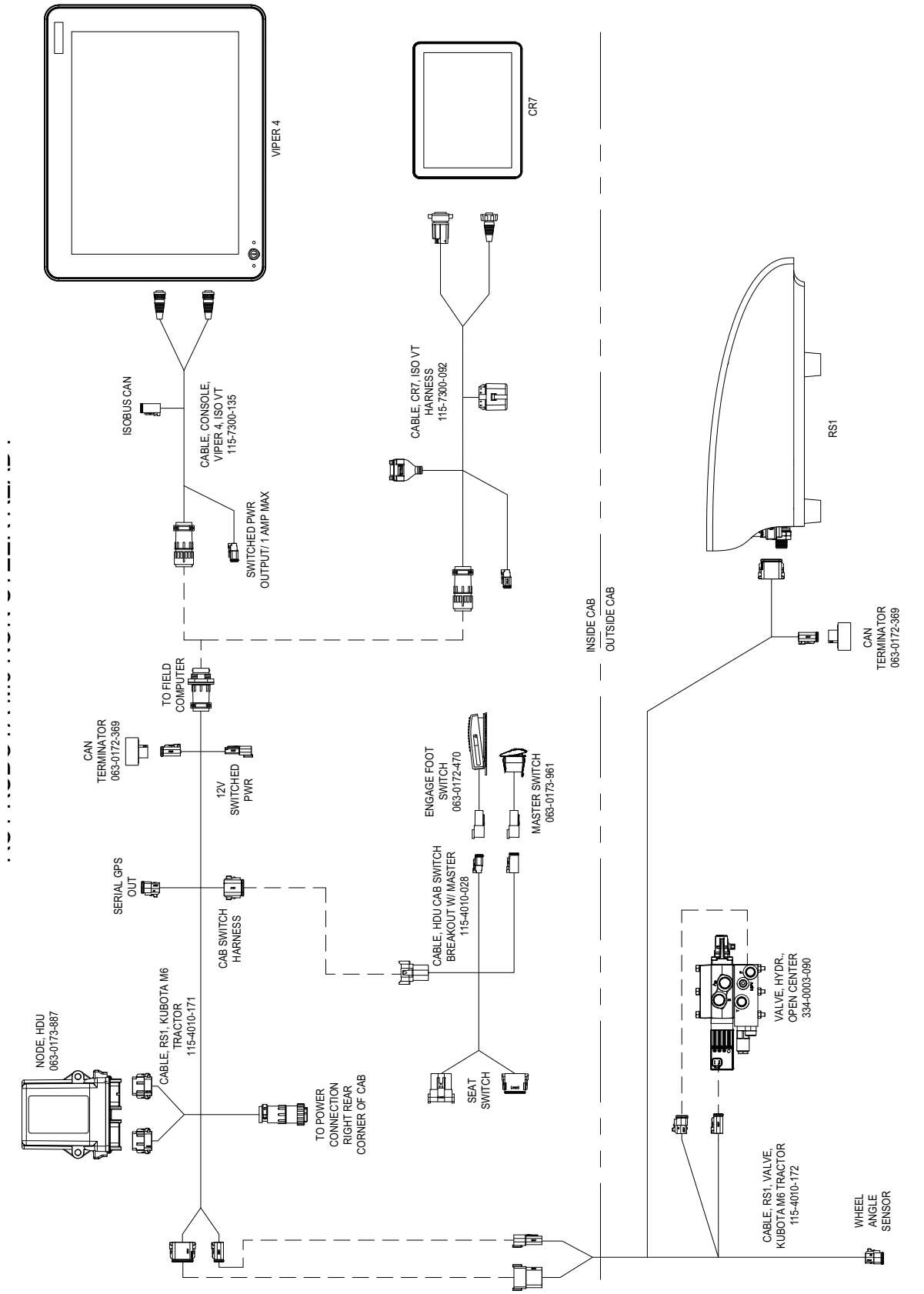



⚠ WARNING

When starting the machine for the first time after installing RS1, be sure that all persons stand clear in case a hose has not been properly tightened.



⚠ WARNING

Do not use hands to check for leaks. Hydraulic fluid under pressure can penetrate the skin and cause serious injury or death.

VERIFY THE SYSTEM INSTALLATION

1. Turn on the machine.
2. Double-check all fitting and hose connections to ensure that:
 - Hoses are not rubbing on or interfering with moving parts.
 - Hydraulic fluid is not leaking from the system.
3. Turn the wheels fully from side to side repeatedly to remove air from the hydraulic system.

NOTE: During the system installation, whenever the hydraulic system is purged for maintenance, or when fittings are loosened to disconnected, air is introduced into the lines of the hydraulic system. If air pockets are present, the wheels may not move consistently when the steering wheel is turned.

4. Continue turning the wheels until they move steadily and smoothly when the steering wheel is turned.

NOTE: If there are issues with the system, turn off the machine and correct them immediately. For additional assistance, refer to the RS1 Calibration and Operation Manual (P/N 016-4010-005) or contact your local Raven dealer.

C

Cab Component and Sensor Installation 27

E

Electrical Safety 3

H

Hydraulic Safety 2

Hydraulic System Installation

 Installing Fittings in the Hydraulic Steering Valve 14

 Installing the Pressure and Tank Hoses 21

 Mounting the Hydraulic Steering and Dual POCI
 Valves 16

I

Important Safety Information

 Electrical Safety 3

 General 3

 Instructions for Wire Routing 3

 Hydraulic Safety 2

 General 2

 Instructions for Hose Routing 2

Introduction

 Kit Contents 8

 Preparing or Installation 7

 Point of Reference 8

 Recommendations 7

 Tools Needed 8

 Updates 8

K

Kit Contents 8

P

Preparing for Installation 7

S

Startup Procedures

 Verify the System Installation 41

LIMITED WARRANTY

WHAT DOES THIS WARRANTY COVER?

This warranty covers all defects in workmanship or materials in your Raven Applied Technology Division product under normal use, maintenance, and service when used for intended purpose.

HOW LONG IS THE COVERAGE PERIOD?

Raven Applied Technology products are covered by this warranty for 12 months from the date of retail sale. In no case will the Limited Warranty period exceed 24 months from the date the product was issued by Raven Industries Applied Technology Division. This warranty coverage applies only to the original owner and is non-transferable.

HOW CAN I GET SERVICE?

Bring the defective part and proof of purchase to your Raven dealer. If the dealer approves the warranty claim, the dealer will process the claim and send it to Raven Industries for final approval. The freight cost to Raven Industries will be the customer's responsibility. The Return Materials Authorization (RMA) number must appear on the box and all documentation (including proof of purchase) must be included inside the box to be sent to Raven Industries.

WHAT WILL RAVEN INDUSTRIES DO?

Upon confirmation of the warranty claim, Raven Industries will (at our discretion) repair or replace the defective product and pay for the standard return freight, regardless of the inbound shipping method. Expedited freight is available at the customer's expense.

WHAT IS NOT COVERED BY THIS WARRANTY?

Raven Industries will not assume any expense or liability for repairs made outside our facilities without written consent. Raven Industries is not responsible for damage to any associated equipment or products and will not be liable for loss of profit, labor, or other damages. The obligation of this warranty is in lieu of all other warranties, expressed or implied, and no person or organization is authorized to assume any liability for Raven Industries.

Damages caused by normal wear and tear, misuse, abuse, neglect, accident, or improper installation and maintenance are not covered by this warranty.

EXTENDED WARRANTY

WHAT DOES THIS WARRANTY COVER?

This warranty covers all defects in workmanship or materials in your Raven Applied Technology Division product under normal use, maintenance, and service when used for intended purpose.

DO I NEED TO REGISTER MY PRODUCT TO QUALIFY FOR THE EXTENDED WARRANTY?

Yes. Products/systems must be registered within 30 days of retail sale to receive coverage under the Extended Warranty. If the component does not have a serial tag, the kit it came in must be registered instead.

WHERE CAN I REGISTER MY PRODUCT FOR THE EXTENDED WARRANTY?

To register, go online to www.ravenhelp.com and select Product Registration.

HOW LONG IS THE EXTENDED WARRANTY COVERAGE PERIOD?

Raven Applied Technology products that have been registered online are covered for an additional 12 months beyond the Limited Warranty for a total coverage period of 24 months from the date of retail sale. In no case will the Extended Warranty period exceed 36 months from the date the product was issued by Raven Industries Applied Technology division. This Extended Warranty coverage applies only to the original owner and is non-transferable.

HOW CAN I GET SERVICE?

Bring the defective part and proof of purchase to your Raven dealer. If the dealer approves the warranty claim, the dealer will process the claim and send it to Raven Industries for final approval. The freight cost to Raven Industries will be the customer's responsibility. The Return Materials Authorization (RMA) number must appear on the box and all documentation (including proof of purchase) must be included inside the box to be sent to Raven Industries. In addition, the words "Extended Warranty" must appear on the box and all documentation if the failure is between 12 and 24 months from the retail sale.

WHAT WILL RAVEN INDUSTRIES DO?

Upon confirmation of the product's registration for the Extended Warranty and the claim itself, Raven Industries will (at our discretion) repair or replace the defective product and pay for the standard return freight, regardless of the inbound shipping method. Expedited freight is available at the customer's expense.

WHAT IS NOT COVERED BY THE EXTENDED WARRANTY?

Raven Industries will not assume any expense or liability for repairs made outside our facilities without written consent. Raven Industries is not responsible for damage to any associated equipment or products and will not be liable for loss of profit, labor, or other damages. Cables, hoses, software enhancements, and remanufactured items are not covered by this Extended Warranty. The obligation of this warranty is in lieu of all other warranties, expressed or implied, and no person or organization is authorized to assume any liability for Raven Industries.

Damages caused by normal wear and tear, misuse, abuse, neglect, accident, or improper installation and maintenance are not covered by this warranty.