

VSN/RDR Installation Manual for AGCO RoGator C

016-2023-002 Rev. C

2/2022

E40237



DISCLAIMER

While every effort has been made to ensure the accuracy of this document, Raven Industries assumes no responsibility for omissions and errors. Nor is any liability assumed for damages resulting from the use of information contained herein.

Raven Industries shall not be responsible or liable for incidental or consequential damages or a loss of anticipated benefits or profits, work stoppage or loss, or impairment of data arising out of the use, or inability to use, this system or any of its components. Raven Industries shall not be held responsible for any modifications or repairs made outside our facilities, nor damages resulting from inadequate maintenance of this system.

As with all wireless and satellite signals, several factors may affect the availability and accuracy of wireless and satellite navigation and correction services (e.g. GPS, GNSS, SBAS, etc.). Therefore, Raven Industries cannot guarantee the accuracy, integrity, continuity, or availability of these services and cannot guarantee the ability to use Raven systems, or products used as components of systems, which rely upon the reception of these signals or availability of these services. Raven Industries accepts no responsibility for the use of any of these signals or services for other than the stated purpose.

| | | |
|-------------------------------------|--|-----------|
| Chapter 1 | Important Safety Information..... | 1 |
| General | | 2 |
| Instructions for Wire Routing | | 2 |
| Chapter 2 | Introduction..... | 5 |
| Preparing for Installation | | 5 |
| Prerequisites | | 5 |
| Recommendations | | 5 |
| Point of Reference | | 5 |
| Updates | | 6 |
| Kit Contents | | 6 |
| Chapter 3 | Installation | 9 |
| Mounting VSN | | 9 |
| Cabling and Connection | | 12 |
| VSN Cab Cable | | 13 |
| VSN Camera Cable | | 18 |
| Reflective Decals | | 19 |
| Install Radar | | 20 |
| Route the Cables | | 22 |

CHAPTER

1

IMPORTANT SAFETY INFORMATION

NOTICE

Read this manual and the operation and safety instructions included with your implement and/or controller carefully before installing the VSN system.

- Follow all safety information presented within this manual.
- If you require assistance with any portion of the installation or service of your Raven equipment, contact your local Raven dealer for support.
- Follow all safety labels affixed to the VSN system components. Be sure to keep safety labels in good condition and replace any missing or damaged labels. To obtain replacements for missing or damaged safety labels, contact your local Raven dealer.

When operating the machine after installing VSN, observe the following safety measures:

- Be alert and aware of surroundings.
- Do not operate VSN or any agricultural equipment while under the influence of alcohol or an illegal substance.
- Remain in the operator's position or a safe working distance away from the booms at all times when VSN is engaged.
- Disable VSN when exiting from the operator's seat and machine.
- Do not drive the machine with VSN enabled on any public road.
- Determine and remain a safe working distance from other individuals. The operator is responsible for disabling VSN when the safe working distance has diminished.
- Ensure VSN is disabled prior to starting any maintenance work on VSN or the machine.

WARNING

- The machine must remain stationary and switched off, with the booms unfolded and supported, during installation or maintenance.

CAUTION

GENERAL

- Always verify that the power leads are connected to the correct polarity as marked. Reversing the power leads could cause severe damage to the equipment.
- Ensure that the power cable is the last cable to be connected.
- A minimum of 12 VDC is required for system operation with a maximum of 15 VDC.

INSTRUCTIONS FOR WIRE ROUTING

The word “harness” is used to mean all electrical leads and cables, bundled and unbundled. When installing harness, secure it at least every 30 cm (12in) to the frame. Follow existing harness as much as possible and use these guidelines:

Harness should not contact or be attached to:

- Lines and hoses with high vibration forces or pressure spikes
- Lines and hoses carrying hot fluids beyond harness component specifications

Avoid contact with any sharp edge or abrading surfaces such as, but not limited to:

- Sheared or flame cut edges
- Edges of machined surfaces
- Fastener threads or cap screw heads
- Ends of adjustable hose clamps
- Wire exiting conduit without protection, either ends or side of conduit
- Hose and tube fittings

Routing should not allow harnesses to:

- Hang below the unit
- Have the potential to become damaged due to exposure to the exterior environment. (i.e. tree limbs, debris, attachments)
- Be placed in areas of or in contact with machine components which develop temperatures higher than the temperature rating of harness components
- Wiring should be protected or shielded if it needs to route near hot temperatures beyond harness component specifications

Harnessing should not have sharp bends

Allow sufficient clearance from machine component operational zones such as:

- Drive shafts, universal joints and hitches (i.e. 3-point hitch)
- Pulleys, gears, sprockets
- Deflection and backlash of belts and chains
- Adjustment zones of adjustable brackets

- Changes of position in RS1 HD and suspension systems
- Moving linkages, cylinders, articulation joints, attachments
- Ground engaging components

For harness sections that move during machine operation:

- Allow sufficient length for free movement without interference to prevent: pulling, pinching, catching or rubbing, especially in articulation and pivot points
- Clamp harnesses securely to force controlled movement to occur in the desired harness section
- Avoid sharp twisting or flexing of harnesses in short distances
- Connectors and splices should not be located in harness sections that move

Protect harnesses from:

- Foreign objects such as rocks that may fall or be thrown by the unit
- Buildup of dirt, mud, snow, ice, submersion in water and oil
- Tree limbs, brush and debris
- Damage where service personnel or operators might step or use as a grab bar
- Damage when passing through metal structures

IMPORTANT:

- Avoid directly spraying electrical components and connections with high pressure water. High pressure water sprays can penetrate seals and cause electrical components to corrode or otherwise become damaged. When performing maintenance:
- Inspect all electrical components and connections for damage or corrosion. Repair or replace components, connections, or cable as necessary.
- Ensure connections are clean, dry, and not damaged. Repair or replace components, connections, or cable as necessary.
- Clean components or connections using low pressure water, pressurized air, or an aerosol electrical component cleaning agent.
- Remove visible surface water from components, connections, or seals using pressurized air or an aerosol electrical component cleaning agent. allow components to dry completely before reconnecting cables.

Congratulations on your purchase of the VSN system!

The following instructions are designed to assist with the proper installation of the VSN system. Refer to the VSN Calibration & Operation Manual (P/N 016-2020-001) for assistance with calibrating and using the VSN system.

PREPARING FOR INSTALLATION

Before installing the VSN system, park the machine where the ground is level, clean, and dry. Turn off the machine and leave it turned off for the duration of the installation process.

During the installation process, follow good safety practices. Be sure to carefully read the instructions in this manual to complete the installation process.

PREREQUISITES

The following components must be installed with the VSN system.

- VSN version 20.4 or newer
- RS1™
- Viper® 4 with ROS version 3.4 or newer

Follow the installation instructions provided with these components before installing VSN.

RECOMMENDATIONS

Raven Industries recommends the following best practices when installing or operating the VSN system for the first time or at the start of the season:

- Install the VSN unit in the recommended location.
- Use part numbers to help identify parts.
- Do not remove the plastic wrap from a part until it is necessary for installation.

POINT OF REFERENCE

The instructions in this manual assume that you are standing behind the machine, looking toward the cab.

UPDATES

Software and manual updates are available on the Raven Applied Technology website:

<http://www.ravenprecision.com>

At Raven Industries, we strive to make your experience with our products as rewarding as possible. One way to improve this experience is to provide us with feedback on this manual.

Your feedback will help shape the future of our product documentation and the overall service we provide. We appreciate the opportunity to see ourselves as our customers see us and are eager to gather ideas on how we have been helping or how we can do better.

To serve you best, please send an email with the following information to

techwriting@ravenind.com

- VSN/RDR Installation Manual for AGCO RoGator C
- 016-2023-002 Rev. C
- Any comments or feedback (include chapter or page numbers if applicable).
- Let us know how long have you been using this or other Raven products.

We will not share your email or any information you provide with anyone else. Your feedback is valued and extremely important to us.

Thank you for your time.

KIT CONTENTS

This section contains a list of the components that are included in the VSN kit. Before beginning the system installation, compare the items in the kit with the components on this list. If you have questions about the kit, contact your Raven dealer.

FIGURE 1. VSN Installation Kit for AGCO RoGator C

THIS KIT TO CONTAIN THE FOLLOWING ITEMS LISTED BELOW:

| ITEM # | QTY | PART # | DESCRIPTION |
|--------|-----|---------------|--|
| 1 | 1 | 053-0159-087 | BOX, SHIPPING |
| 2 | 1 | 115-2020-007 | CABLE, VSN, ROGATOR C |
| 3 | 1 | 115-2020-008 | CABLE, VSN, ROGATOR C CAB |
| 4 | 1 | 116-0159-835 | WELDMENT, VSN, FRAME MOUNT, AGCO B/C |
| 5 | 1 | 116-0159-837 | WELDMENT, VSN MOUNT |
| 6 | 1 | 107-0172-642 | SHIELD, DEBRIS, VSN |
| 7 | 1 | 016-0171-649 | SHEET, WARRANTY/HELP (016-2023-002) |
| 8 | 1 | 053-0159-074 | ENVELOPE, PLASTIC |
| 9 | 4 | 107-0172-547 | UBOLT, 4 1/32 X 5 1/4 X 3/8-16 UNC |
| 10 | 8 | 312-4000-252 | NUT, FLANGE LOCK, 3/8-16 UNC *REMOVED* |
| 11 | 1 | 053-0159-074 | ENVELOPE, PLASTIC |
| 12 | 8 | 311-4055-180N | BOLT, M8-1.25 X 25MM, CLASS V COATING |
| 13 | 4 | 313-6001-013N | WASHER, LOCK, M8, CLASS V COATING |
| 14 | 12 | 313-6000-013N | WASHER, M8, CLASS V COATING |
| 15 | 4 | 312-6001-027N | NUT, NYLOC, M8-1.25, CLASS V COATING |
| 16 | 4 | 313-5001-007 | GASKET, VITON, .29 I.D. x .688 O.D. x .062 THK |
| 17 | 2 | 041-0159-940 | REFLECTOR, PRESSURE SENSITIVE, YELLOW, 50X230 |

MOUNTING VSN

| | |
|---|--|
|  | <p>⚠ WARNING</p> <p>Unfold and lower the booms during the installation process.</p> |
|---|--|

1. Locate the rubber boom cushion or boom cradle bracket mounted to the top of the right boom cradle.
2. Loosen the hardware holding the cushion or cradle bracket to the cradle frame.

FIGURE 1. Cradle Frame Cushion Hardware



Loosen
Hardware

FIGURE 2. Cradle Bracket Hardware for Millennium Boom Configurations

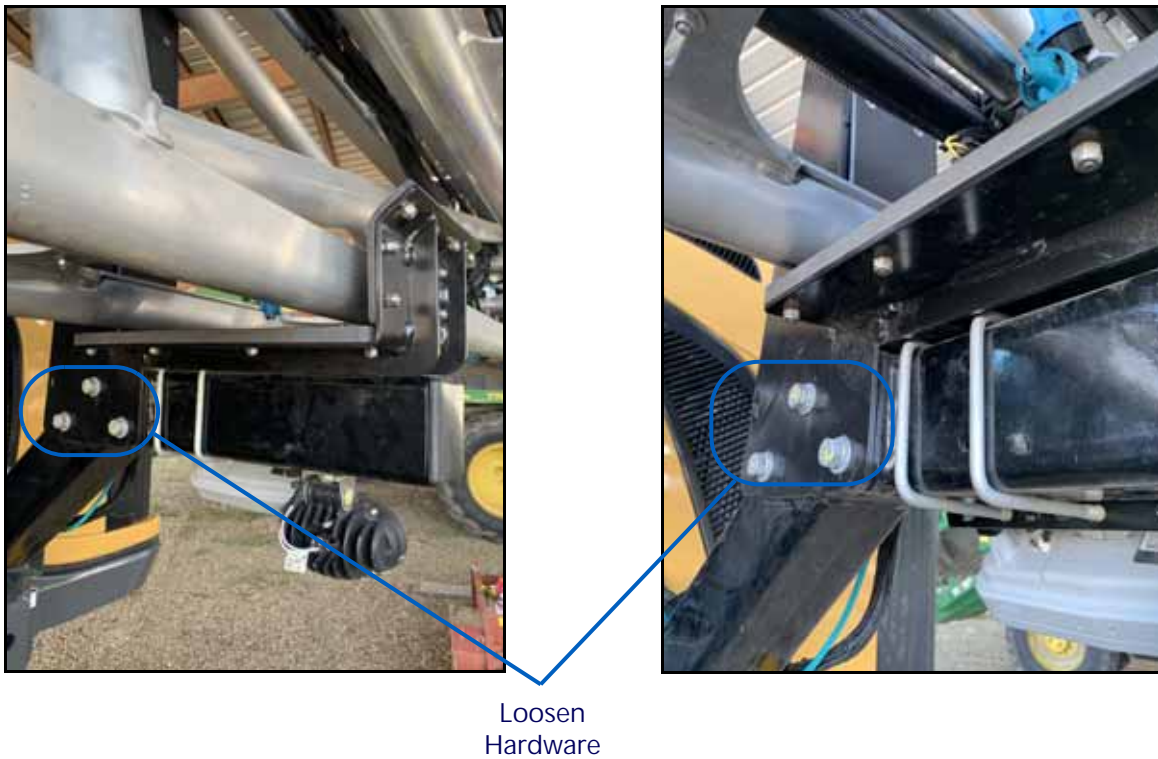

3. Install the provided u-bolts around the cradle frame and between the frame and cushion or cradle bracket.

FIGURE 3. Right Boom Cradle

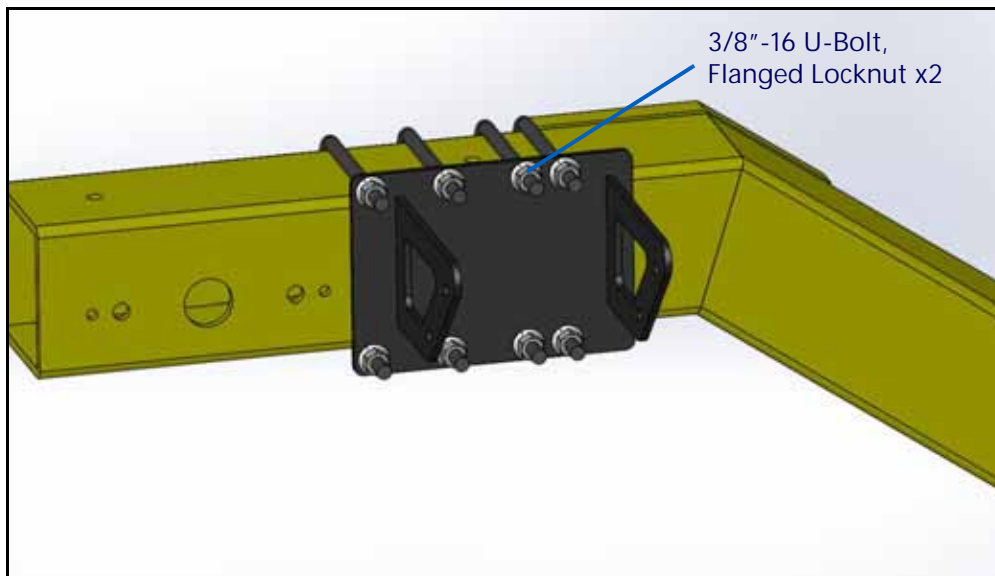

4. Using the provided 3/8" flanged lock nuts, secure the VSN base bracket to the cradle framework.
5. Retighten the hardware holding the cushion or cradle bracket to the cradle frame.

- Using the provided M8 hardware, mount the debris shield and brackets to the back of the VSN camera as shown in Figure 4 on page 11.

NOTE: The camera must be mounted with the lens at the top when mounted to the equipment.

FIGURE 4. VSN Camera and Mounting Bracket Assembly

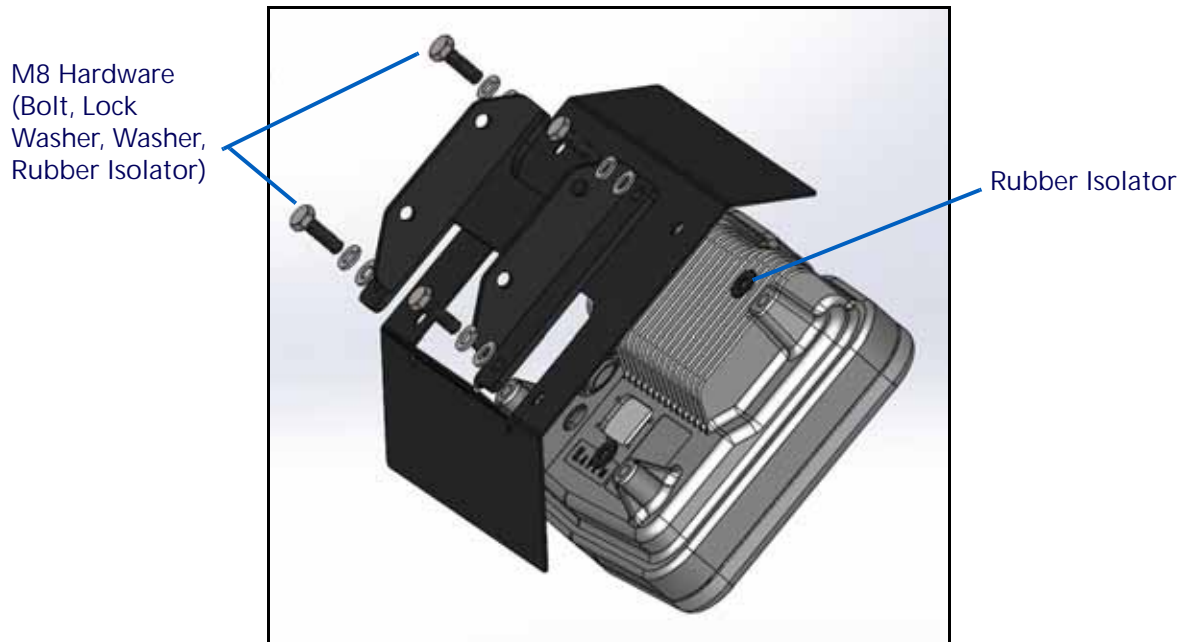

- Finally, use the remaining M8 hardware to secure the camera mounting bracket assembly to the base bracket on the machine frame.

FIGURE 5. VSN Camera Mounted to Boom Cradle

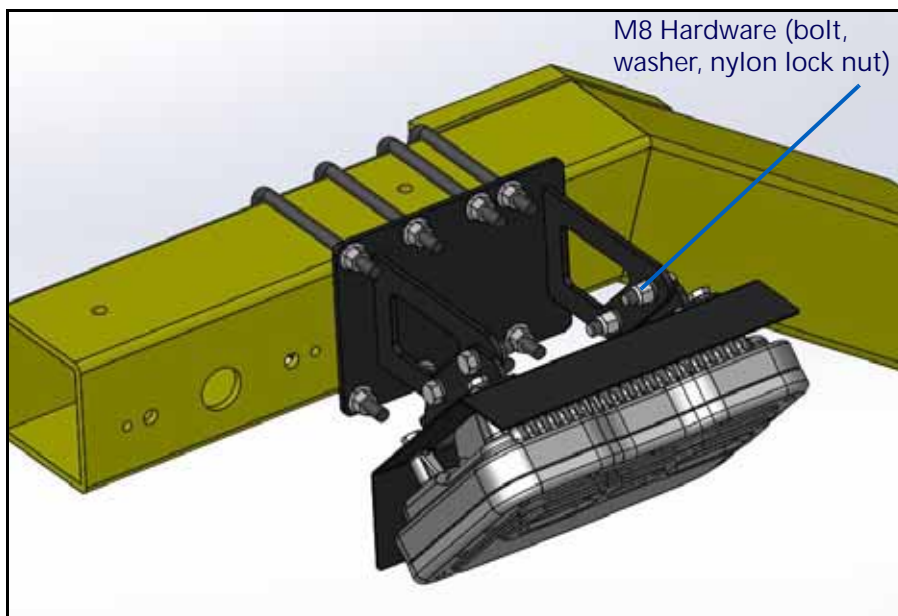

CABLING AND CONNECTION

FIGURE 6. VSN Steering System Diagram for AGCO RoGator C (P/N 054-2023-002 Rev. B)

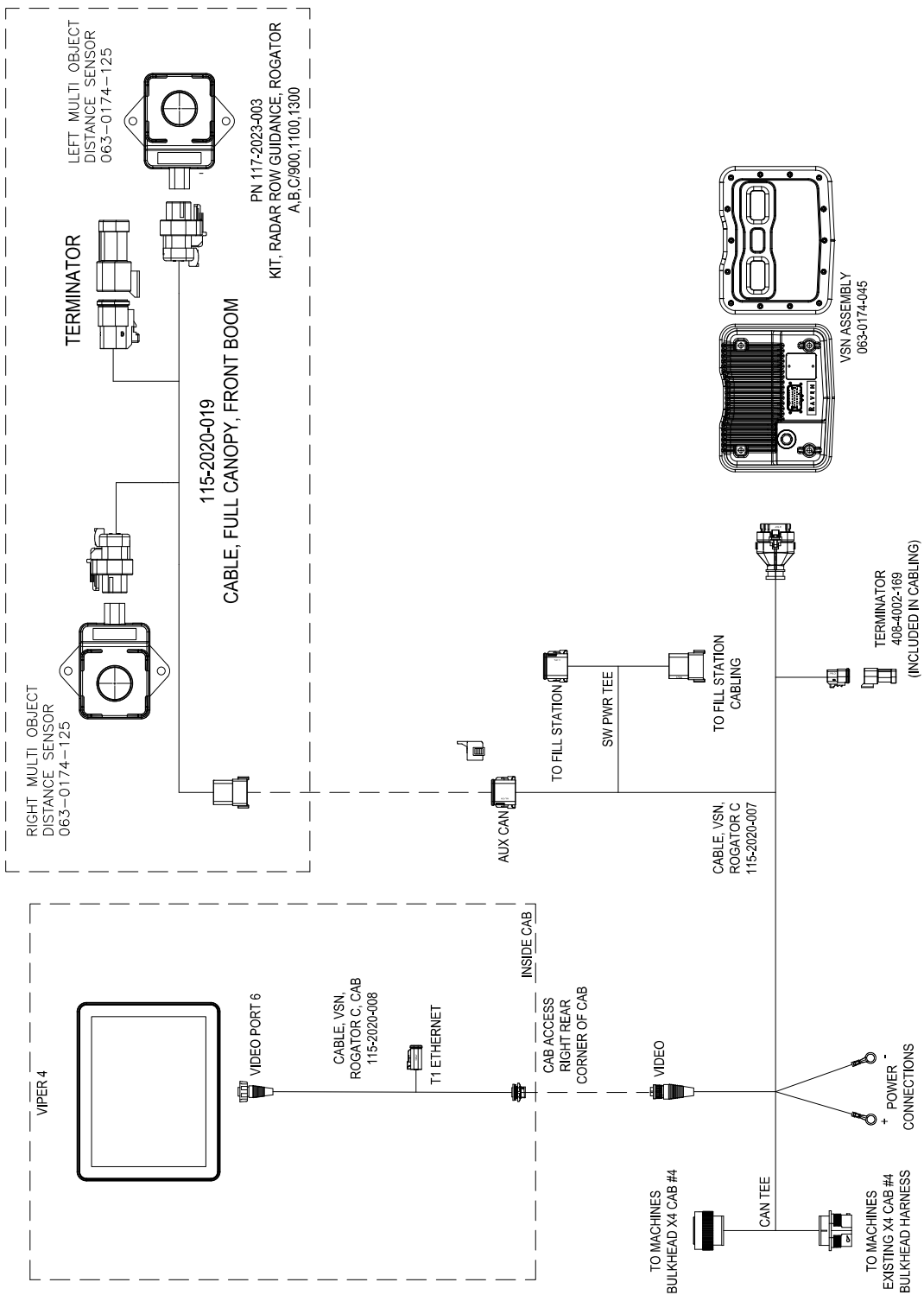

VSN CAB CABLE

1. Locate and remove the exterior access panel on the right, rear of the cab.

FIGURE 7. Exterior Cab Access Panel Removed from Right Rear



2. Locate and punch out one pass-through provision inside the access panel to provide access into the cab.

NOTE: If all pass-through provisions are in use, an additional hole will need to be drilled within the access panel.

FIGURE 8. Pass-Through Provisions inside Right Rear Access Panel

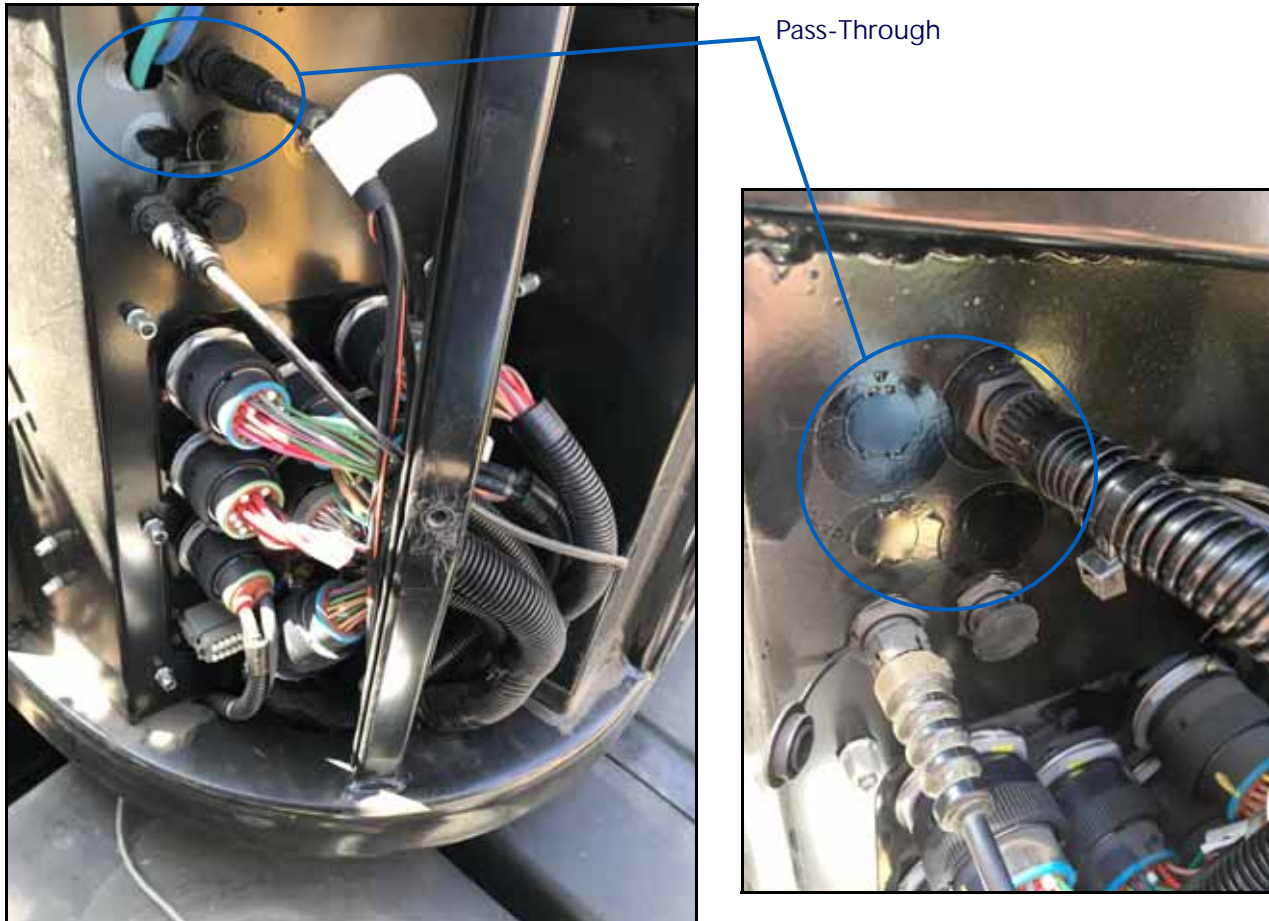

3. On the interior of the vehicle cab, locate and remove the access panels along the right side of the cab.

FIGURE 9. Interior Access Panels Removed from Right Rear

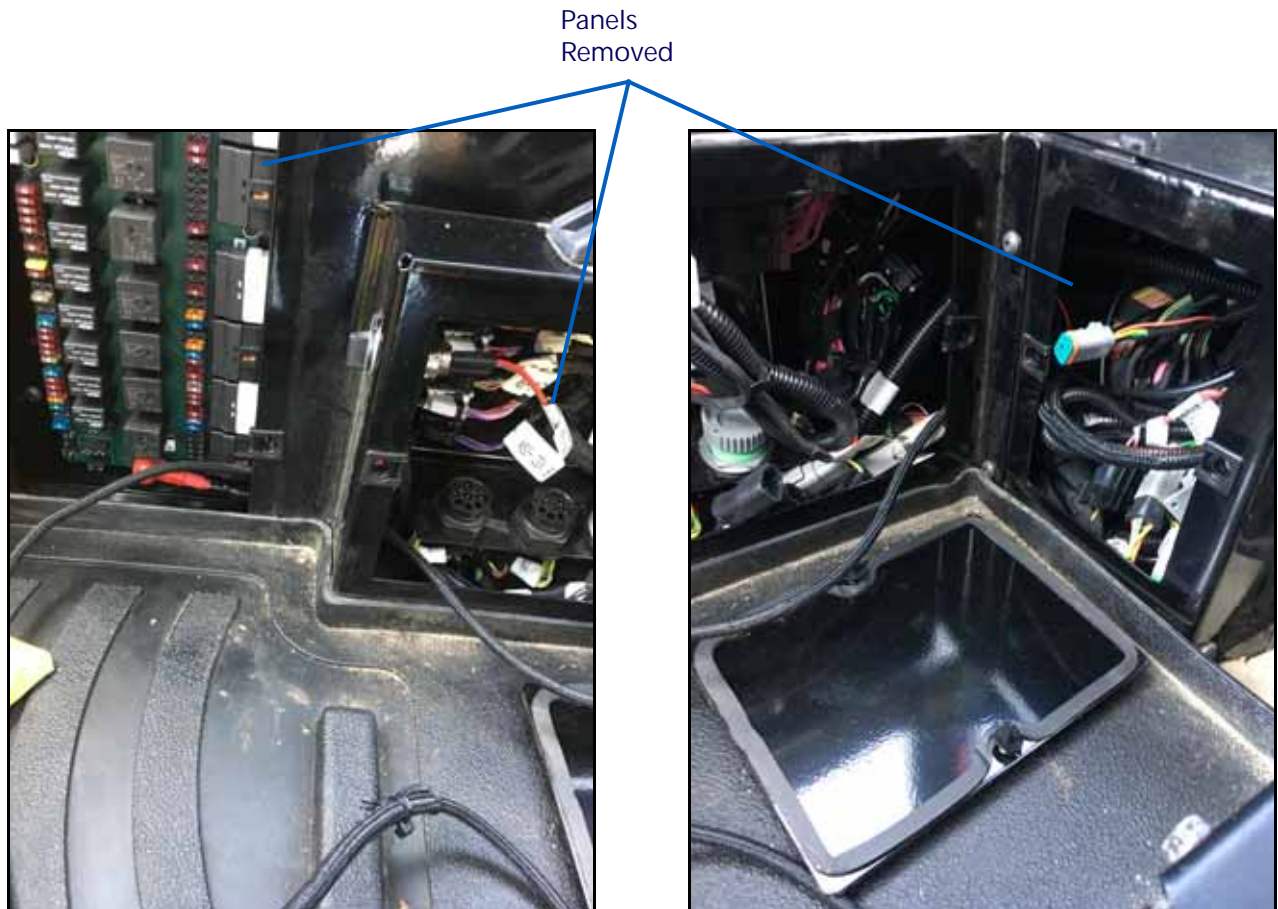

4. Route the 7-pin bulkhead connector on the VSN Cab cable (P/N 115-2020-008) into the interior access panel and secure to the bulkhead in the removed pass-through provision using the jam nut provided on the connector.

FIGURE 10. Bulkhead Access Point

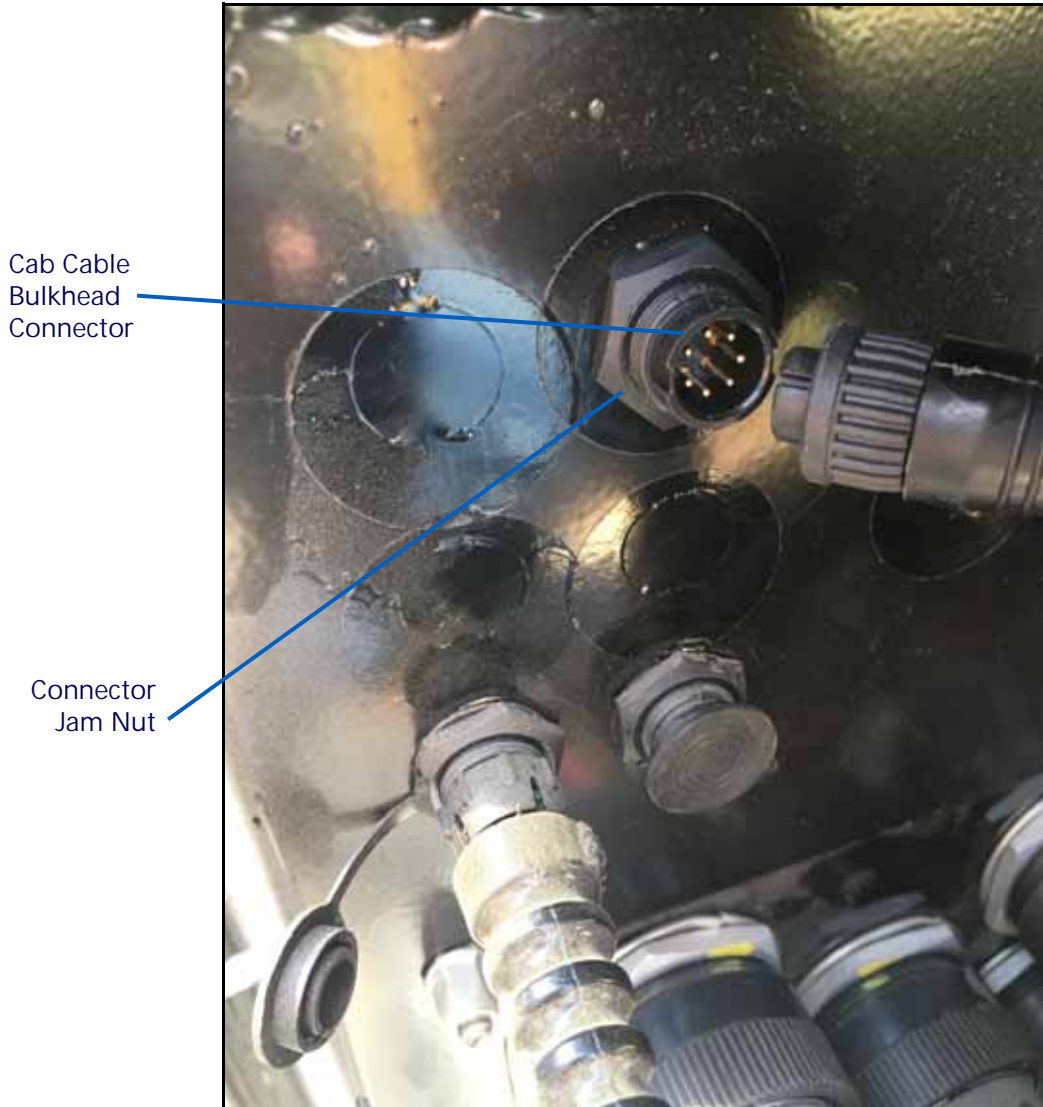

5. Route the remaining end of the cab cable to the Viper 4 and connect to Port 6.

FIGURE 11. Viper 4 Connection



VSN CAMERA CABLE

1. Route the end of the VSN camera cable (P/N 115-2020-007) with the round 35 pin connectors up through the opening at the bottom of the area behind the exterior access panel.
2. Locate and disconnect the four round bulkhead connections labeled X3, X4, X5 and X6 to gain access to the power connections and the X4 Cab #4 connection.

NOTE: Label the bulkhead connectors to ensure proper re-connection.

FIGURE 12. Exterior Cab Access Panel

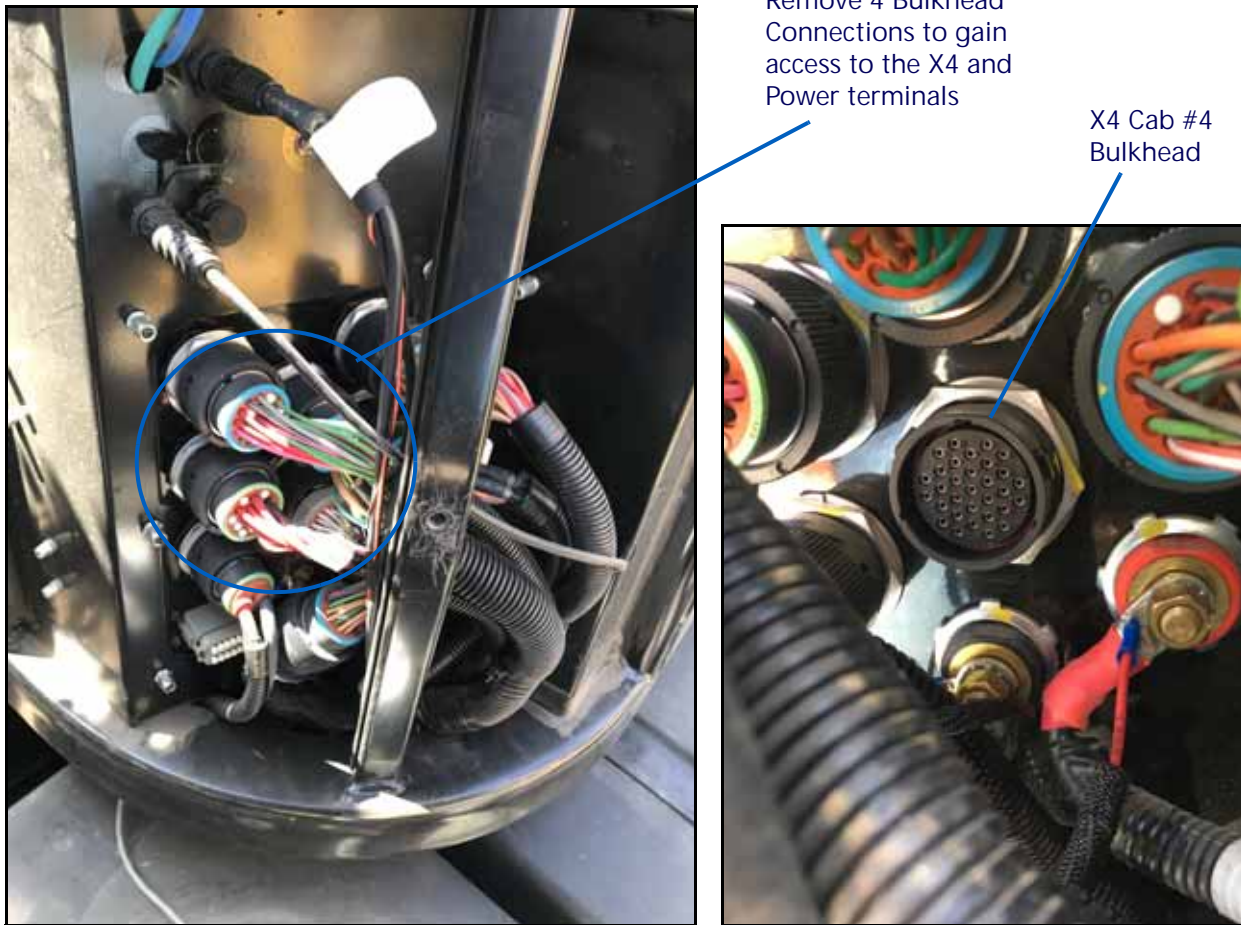

3. Locate the power connections and install the power ring terminal on the red power stud and the ground ring terminal on the black ground stud.
4. Locate the X4 Cab #4 bulkhead and connector. Tee in the appropriate connectors of the VSN camera cable (P/N 115-2020-007).
5. Reinstall the previously removed bulkhead connections.
6. Locate the round 7-pin connector labeled VIDEO on the VSN camera cable (P/N 115-2020-007) and connect it to the bulkhead port installed in the previous section (refer to Figure 8 on page 15).
7. Route the gray 23-pin connector along the frame to the right boom cradle.

NOTE: Be sure the cable is routed to prevent the cable from being pinched by the boom or other moving components of the equipment.

8. Connect the 23-pin connector to the back of the VSN camera.

FIGURE 13. VSN Camera Connection

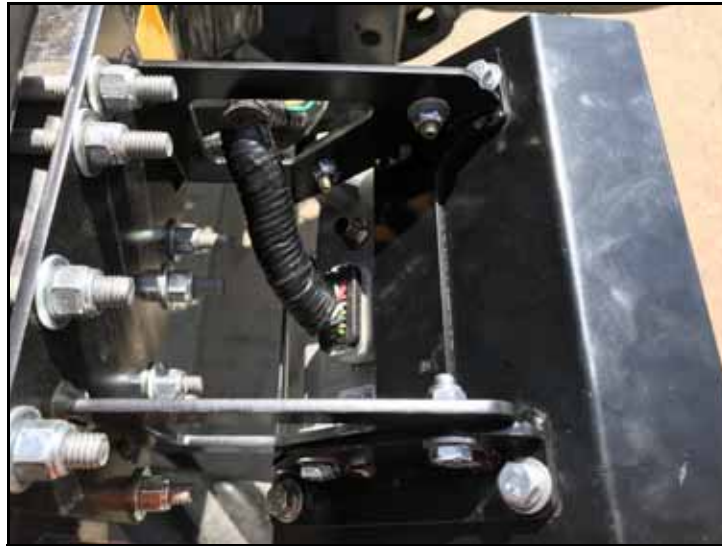

9. Locate the fill station control box on the right, front of the machine.

FIGURE 14. Switched Power Tee Connection



10. Disconnect the 12-pin connector and tee in the connector breakouts labeled SW PWR TEE.

REFLECTIVE DECALS

When mounted, the VSN assembly may cover factory installed reflective decals.

The included decals (P/N 041-0159-940) must be installed on the boom cradle or machine frame to restore and maintain visibility after the VSN assembly is mounted. Trim the decals as needed to fit the location to which each will be affixed.

INSTALL RADAR

FIGURE 15. Radar Row Guidance Kit for RoGator A,B,C / 900, 1100, 1300 (P/N 117-2023-003 Rev. C)

HIS KIT TO CONTAIN THE FOLLOWING ITEMS LISTED BELOW

| QTY | PART # | DESCRIPTION |
|-----|---------------|---|
| 1 | 053-0159-180 | BOX, SHIPPING |
| 2 | 063-0174-125 | RADAR, MULTI OBJECT DISTANCE SENSOR |
| 2 | 107-0172-690 | BRACKET, MULTI OBJECT DISTANCE SENSOR, BASE |
| 2 | 107-0172-694 | BRACKET, ROGATOR C MOUNT, MULTI OBJECT DISTANCE SEN |
| 1 | 115-2020-019 | CABLE, FULL CANOPY, FRONT BOOM |
| 1 | 016-0171-649 | SHEET, WARRANTY/SHEET (016-2023-003) |
| 2 | 116-0159-860 | WELDMENT, MULTI-OBJECT DISTANCE SENSOR, COVER *REMOVED* *REMOVED* |
| 1 | 053-0159-074 | ENVELOPE, PLASTIC |
| 4 | 311-4056-226N | HEX, BOLT, DIN 933, M10 X 1.5 X 40MM |
| 4 | 311-4056-137N | HEX, BOLT, DIN 933, M6 X 1 X 25MM |
| 24 | 313-6000-016N | WASHER, M10, STEEL, CLASS V |
| 8 | 313-6000-010N | WASHER, M6, STEEL, CLASS V |
| 8 | 313-6001-016N | WASHER, SPRING LOCK, DIN 127-M10 |
| 4 | 312-6001-016N | HEX NUT, NYLOC, DIN 985, M6 |
| 6 | 312-6001-041N | HEX NUT, NYLOC, DIN 985, M10 |
| 14 | 311-4056-224N | HEX, BOLT, DIN 933, M10-1.5X30MM *REMOVED* *REMOVED* *REMOVED* |

1. Remove the wheel motor covers on both front axles.

FIGURE 16. Wheel Motor Covers

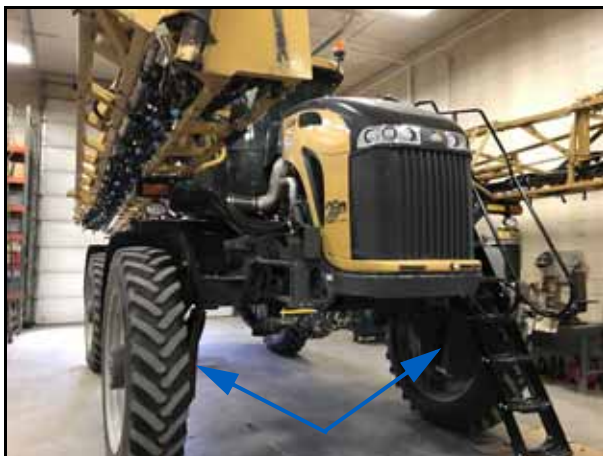
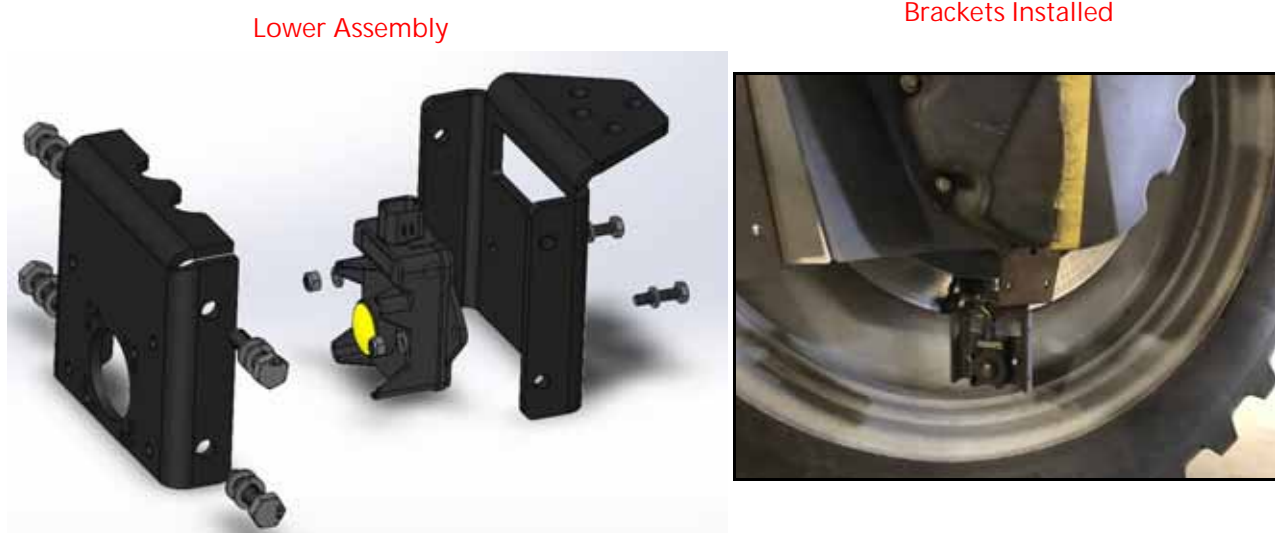

FIGURE 17. Removed Wheel Motor Cover



2. Install the brackets and radar sensors to each side, orientating the sensors at a 45 degree angle forward. The mounting holes will ensure the proper angle is achieved.

FIGURE 18. Lower Assembly and Small Frame Assembly



NOTE: The machine interfacing bracket will mount between the cast wheel part and the plastic shield.

3. Mount the bracket to the machine using the M10x40mm bolts and consult with a dealer for torque specs.
4. Mount the lower assembly to the machine bracket using the M10x30mm bolts, washers, and lock nuts.

NOTE: Prior to installing the sensor cover, record the serial number and whether the sensor is installed on the right or left side of the machine.

The sensor covers should be installed after the cabling is routed.

ROUTE THE CABLES

1. Connect the 115-2020-019 radar sensor cable to the 12-pin Aux Sensor connector on the VSN cable near the VSN as seen in Figure 19, "12-Pin Aux Sensor Connected to VSN Cable," below.

FIGURE 19. 12-Pin Aux Sensor Connected to VSN Cable



IMPORTANT: Ensure to route the cables along all of the hoses that lead to the drive motor to allow for the machine to change tread width without damaging cables.

Do not allow the cables to hang anywhere under the machine to prevent cable damage from crops.

2. Route the cable along hoses with the first 4-pin breakout going to the front right sensor.
3. Ensure hydraulic hoses are followed and route the cable along the hoses protected by the plastic shield.
4. Route the other end of the cable to the front left sensor.

NOTE: Ensure proper cable routing by following hydraulic hoses and routing the cables through the protective covering around the hydraulic hoses (if applicable) for maximum protection.

FIGURE 20. Proper and Improper Cable Routing

Proper



Improper



NOTE: Ensure the cable is routed away from hinge/pinch points under the machine bottom covers.

5. Any excess cabling can be tied up in a secure location between the cab and the product tank.
6. Install the sensor covers using the M10 bolts, washers, and lock washers.
7. Make note of the serial number listed on the radar sensor.

FIGURE 21. Serial Number Location



NOTE: It is important to record the serial number. The radar device will be covered by a cover plate.

FIGURE 22. Secured Cables

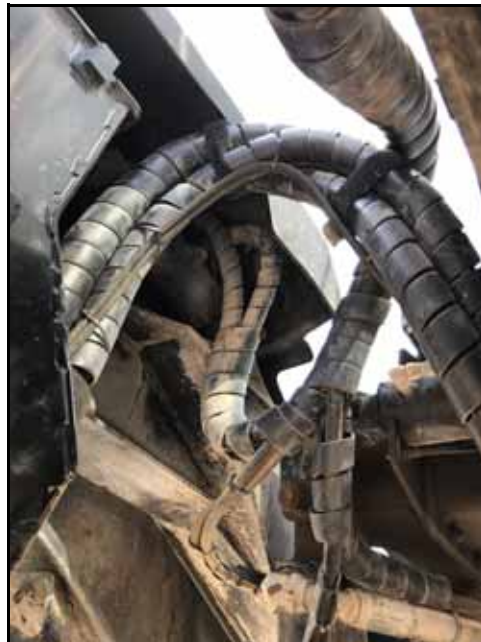

NOTE: Ensure the installed radar brackets will not interfere with the valve stem of the tire when the wheel rotates.

FIGURE 23. Cover Installed



I

| | |
|-------------------------------|---|
| Important Safety Information | |
| Electrical Safety | |
| General | 2 |
| Instructions for Wire Routing | 2 |
| Introduction | 5 |
| Kit Contents | 6 |
| Preparing for Installation | 5 |
| Point of Reference | 5 |
| Recommendations | 5 |
| Updates | 6 |

K

| | |
|--------------|---|
| Kit Contents | 6 |
|--------------|---|

LIMITED WARRANTY

WHAT DOES THIS WARRANTY COVER?

This warranty covers all defects in workmanship or materials in your Raven Applied Technology Division product under normal use, maintenance, and service when used for intended purpose.

HOW LONG IS THE COVERAGE PERIOD?

Raven Applied Technology products are covered by this warranty for 12 months from the date of retail sale. In no case will the Limited Warranty period exceed 24 months from the date the product was issued by Raven Industries Applied Technology Division. This warranty coverage applies only to the original owner and is non-transferable.

HOW CAN I GET SERVICE?

Bring the defective part and proof of purchase to your Raven dealer. If the dealer approves the warranty claim, the dealer will process the claim and send it to Raven Industries for final approval. The freight cost to Raven Industries will be the customer's responsibility. The Return Materials Authorization (RMA) number must appear on the box and all documentation (including proof of purchase) must be included inside the box to be sent to Raven Industries.

WHAT WILL RAVEN INDUSTRIES DO?

Upon confirmation of the warranty claim, Raven Industries will (at our discretion) repair or replace the defective product and pay for the standard return freight, regardless of the inbound shipping method. Expedited freight is available at the customer's expense.

WHAT IS NOT COVERED BY THIS WARRANTY?

Raven Industries will not assume any expense or liability for repairs made outside our facilities without written consent. Raven Industries is not responsible for damage to any associated equipment or products and will not be liable for loss of profit, labor, or other damages. The obligation of this warranty is in lieu of all other warranties, expressed or implied, and no person or organization is authorized to assume any liability for Raven Industries.

Damages caused by normal wear and tear, misuse, abuse, neglect, accident, or improper installation and maintenance are not covered by this warranty.

EXTENDED WARRANTY

WHAT DOES THIS WARRANTY COVER?

This warranty covers all defects in workmanship or materials in your Raven Applied Technology Division product under normal use, maintenance, and service when used for intended purpose.

DO I NEED TO REGISTER MY PRODUCT TO QUALIFY FOR THE EXTENDED WARRANTY?

Yes. Products/systems must be registered within 30 days of retail sale to receive coverage under the Extended Warranty. If the component does not have a serial tag, the kit it came in must be registered instead.

WHERE CAN I REGISTER MY PRODUCT FOR THE EXTENDED WARRANTY?

To register, go online to www.ravenhelp.com and select Product Registration.

HOW LONG IS THE EXTENDED WARRANTY COVERAGE PERIOD?

Raven Applied Technology products that have been registered online are covered for an additional 12 months beyond the Limited Warranty for a total coverage period of 24 months from the date of retail sale. In no case will the Extended Warranty period exceed 36 months from the date the product was issued by Raven Industries Applied Technology division. This Extended Warranty coverage applies only to the original owner and is non-transferable.

HOW CAN I GET SERVICE?

Bring the defective part and proof of purchase to your Raven dealer. If the dealer approves the warranty claim, the dealer will process the claim and send it to Raven Industries for final approval. The freight cost to Raven Industries will be the customer's responsibility. The Return Materials Authorization (RMA) number must appear on the box and all documentation (including proof of purchase) must be included inside the box to be sent to Raven Industries. In addition, the words "Extended Warranty" must appear on the box and all documentation if the failure is between 12 and 24 months from the retail sale.

WHAT WILL RAVEN INDUSTRIES DO?

Upon confirmation of the product's registration for the Extended Warranty and the claim itself, Raven Industries will (at our discretion) repair or replace the defective product and pay for the standard return freight, regardless of the inbound shipping method. Expedited freight is available at the customer's expense.

WHAT IS NOT COVERED BY THE EXTENDED WARRANTY?

Raven Industries will not assume any expense or liability for repairs made outside our facilities without written consent. Raven Industries is not responsible for damage to any associated equipment or products and will not be liable for loss of profit, labor, or other damages. Cables, hoses, software enhancements, and remanufactured items are not covered by this Extended Warranty. The obligation of this warranty is in lieu of all other warranties, expressed or implied, and no person or organization is authorized to assume any liability for Raven Industries.

Damages caused by normal wear and tear, misuse, abuse, neglect, accident, or improper installation and maintenance are not covered by this warranty.