

OMNISEED CABLING CONNECTIONS (TOW BEHIND SYSTEM)

AIR CART KITS:

- 117-3001-035 1 BIN
- 117-3001-036 2 BIN
- 117-3001-026 3 BIN
- 117-3001-027 4 BIN
- 117-3001-028 5 BIN

MAJOR COMPONENTS:

- VALVE, HYD., OMNIROW, PRESS. REDUCING, OC LOW FLOW: 063-0131-141
- VALVE, HYD., PROPORTIONAL FLOW CONTROL 3 WAY: 063-0131-144 (UP TO 3)
- TERMINATOR CAN, PASSIVE, 16 PIN AMP: 063-0173-224
- NODE, CAN, AIR CART, 5 PRODUCT: 063-3001-007
- CODE, AUTHORIZATION, VIPER PRO, GENERIC AIR CART CONTROL: 077-0180-070
- CABLE, CART, GENERIC AIR SEEDER: 115-3001-025
- KIT, FAN SENSOR AIRMAX: 117-0159-575 (2)
- KIT, OMNIROW, PRESSURE TESTING: 117-3001-018
- KIT, HYD., GENERIC AIR CART, 1-3 BIN: 117-3001-029
- SENSOR, BIN LEVEL, CAPACITIVE: 412-6000-008 (UP TO 3)
- MOTOR, HYD. 7/8" HEX, 1GPM, IRC: 416-8000-001 (UP TO 3)

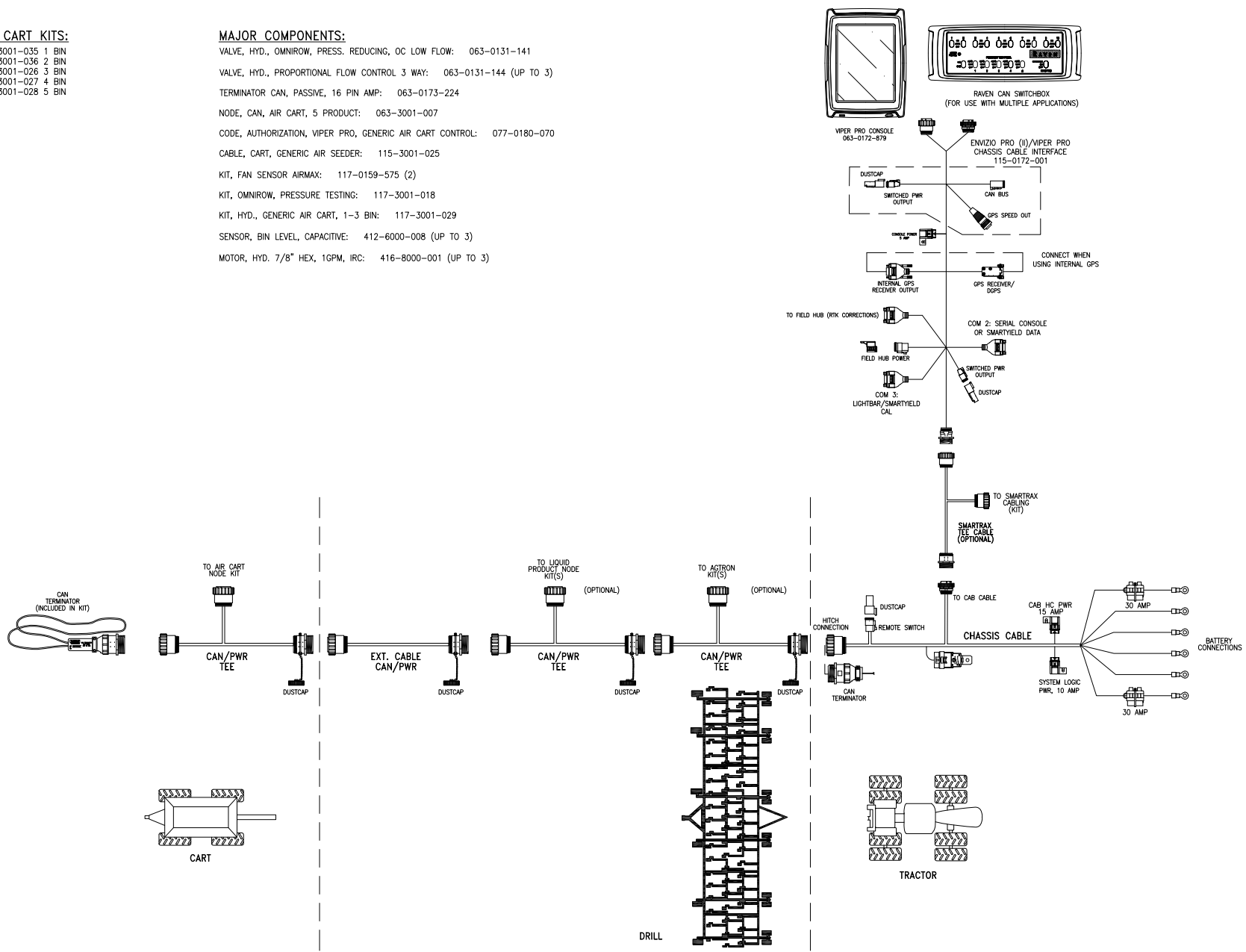

RELEASED DATE	ECO NO.	PROD. MGR.	SERV.	PROD. CHAMP.	ENG.	DRAFT.	REV.	DRAWING NO.
7/20/11	E17929	DP	AT	SAH	BAD	JJP	A	054-5002-001
8/5/15	E22724	TPH	-	CJE	TLH2	MAP	B	-

OMNISEED CABLING CONNECTIONS (TOW BETWEEN SYSTEM)

AIR CART KITS:
 117-3001-035 1 BIN
 117-3001-036 2 BIN
 117-3001-026 3 BIN
 117-3001-027 4 BIN
 117-3001-028 5 BIN

MAJOR COMPONENTS:

VALVE, HYD., OMNIROW, PRESS. REDUCING, OC LOW FLOW: 063-0131-141
 VALVE, HYD., PROPORTIONAL FLOW CONTROL 3 WAY: 063-0131-144 (UP TO 3)
 TERMINATOR CAN, PASSIVE, 16 PIN AMP: 063-0173-224
 NODE, CAN, AIR CART, 5 PRODUCT: 063-3001-007
 CODE, AUTHORIZATION, VIPER PRO, GENERIC AIR CART CONTROL: 077-0180-070
 CABLE, CART, GENERIC AIR SEEDER: 115-3001-025
 KIT, FAN SENSOR AIRMAX: 117-0159-575 (2)
 KIT, OMNIROW, PRESSURE TESTING: 117-3001-018
 KIT, HYD., GENERIC AIR CART, 1-3 BIN: 117-3001-029
 SENSOR, BIN LEVEL, CAPACITIVE: 412-6000-008 (UP TO 3)
 MOTOR, HYD. 7/8" HEX, 1GPM, IRC: 416-8000-001 (UP TO 3)

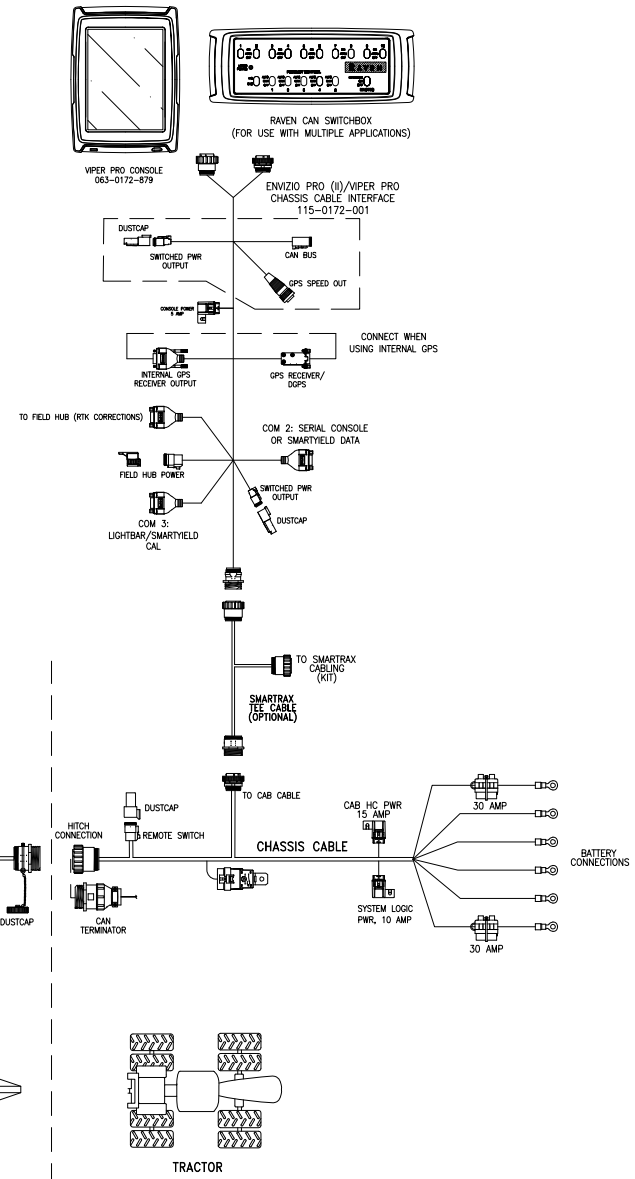
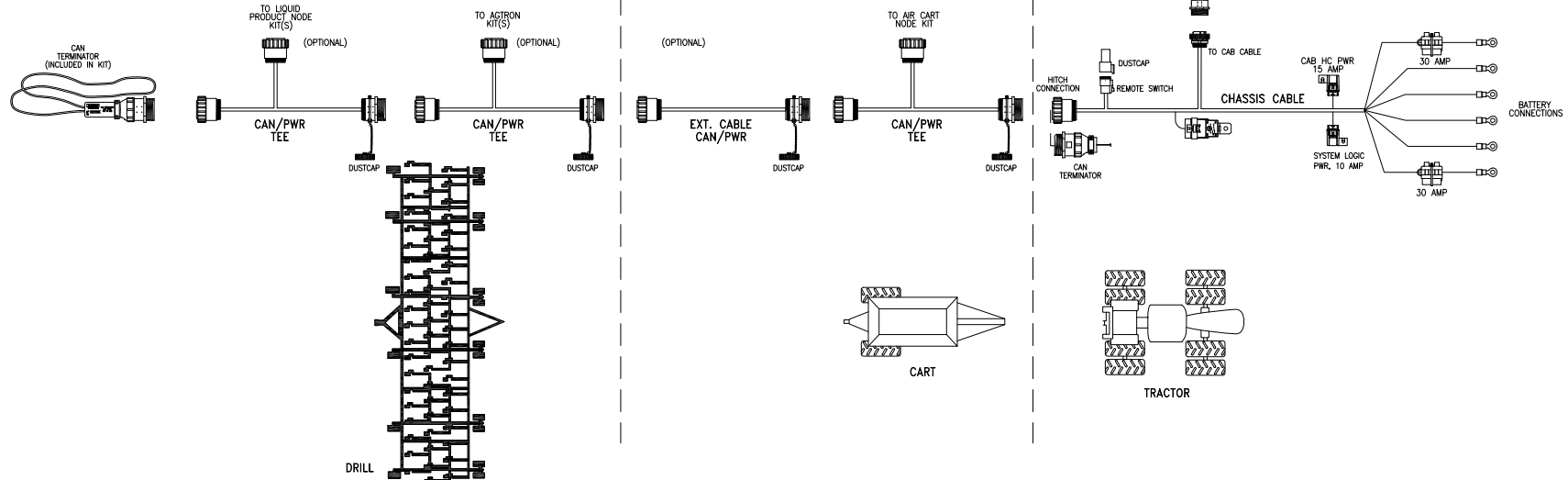

RELEASED DATE	ECO NO.	PROD. MGR.	SERV.	PROD. CHAMP.	ENG.	DRAFT.	REV.	DRAWING NO.
7/20/11	E17929	DP	AT	SAH	BAD	JJP	A	054-5002-001
8/5/15	E22724	TPH	-	CJE	TLH2	MAP	B	-