

REPLACEMENT PARTS, FLOWMETER, RFM-200p

ITEM	DESCRIPTION	RAVEN P/N:
1	BODY, MOLDED, RFM-200p, FLOWMETER	106-0159-711
2	HUB/BEARING ASSEMBLY, UPSTREAM, RFM-200p	063-0173-581
3	RING, RETAINING, WIREFORM, RFM-200	335-0003-199
4	CLAMP, CABLE, PLASTIC, 1/4" x 1/2"	435-3002-017
5	SCREW, THREAD FORMING, #10-16 UNC x 3/8" LONG	310-0002-137
6	TURBINE, STUD/BEARING ASSEMBLY, RFM-200p	063-0159-575
7	TURBINE, FLOWMETER, 4 MAGNET, RFM-200p	063-0173-597
8	STUD, DOWNSTREAM, CUP BEARING, FLOWMETER	063-0173-744
9	SENSOR ASSEMBLY, EXTERNAL, DTM SENSOR ASSEMBLY, EXTERNAL, DT SENSOR ASSEMBLY, EXTERNAL, CON-X-ALL SENSOR ASSEMBLY, EXTERNAL, METRI-PACK (JD)	063-0172-458 063-0172-447 063-0172-004 063-0173-855

REF. KIT 117-0171-645 FOR ITEMS 3, 6, 7, & 8

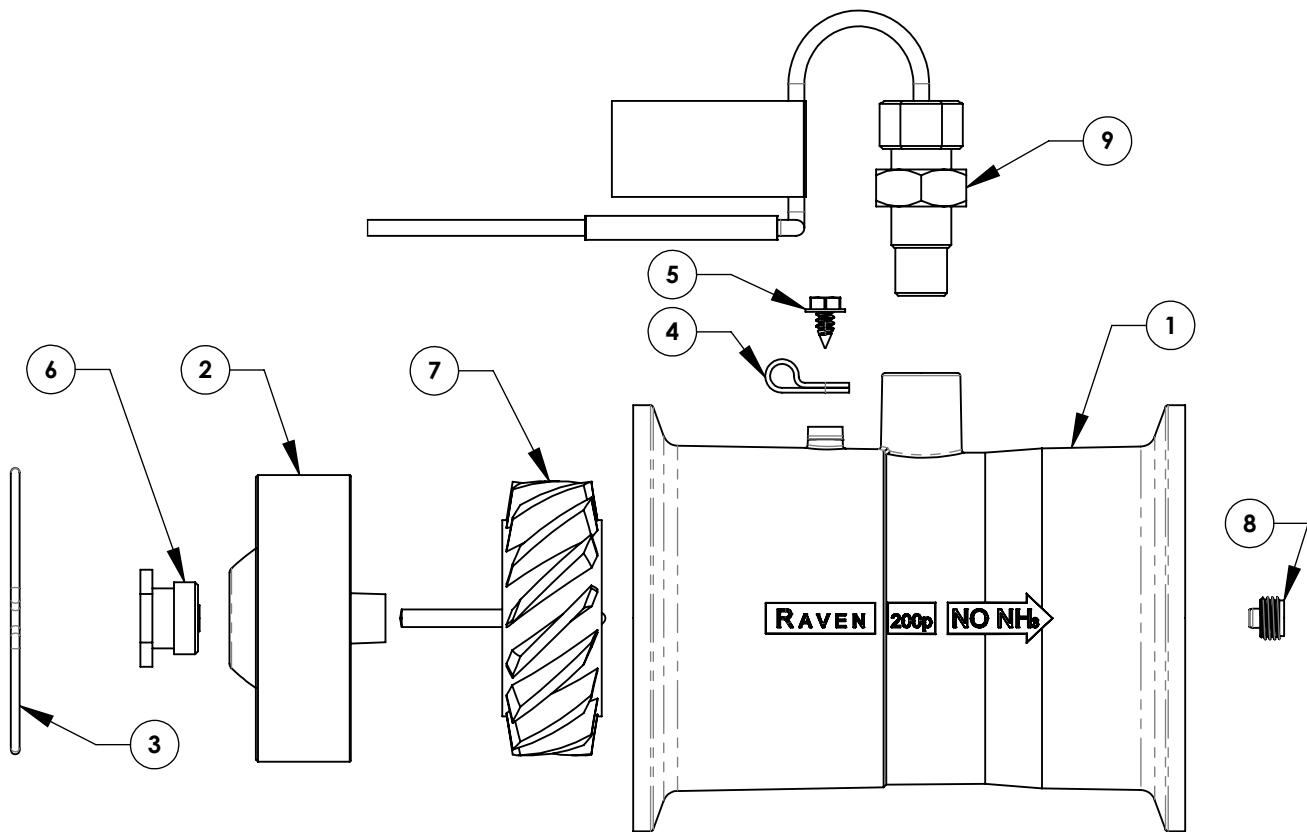

054-0159-346
1/8/18 REV C
SHEET 1 OF 1