

**ISO Product Controller II
and Case IH AIM
Command FLEX™
Calibration and Operation
Manual**

016-0171-628 Rev. F

1/2020

E34273



DISCLAIMER

While every effort has been made to ensure the accuracy of this document, Raven Industries assumes no responsibility for omissions and errors. Nor is any liability assumed for damages resulting from the use of information contained herein.

Raven Industries shall not be responsible or liable for incidental or consequential damages or a loss of anticipated benefits or profits, work stoppage or loss, or impairment of data arising out of the use, or inability to use, this system or any of its components. Raven Industries shall not be held responsible for any modifications or repairs made outside our facilities, nor damages resulting from inadequate maintenance of this system.

As with all wireless and satellite signals, several factors may affect the availability and accuracy of wireless and satellite navigation and correction services (e.g. GPS, GNSS, SBAS, etc.). Therefore, Raven Industries cannot guarantee the accuracy, integrity, continuity, or availability of these services and cannot guarantee the ability to use Raven systems, or products used as components of systems, which rely upon the reception of these signals or availability of these services. Raven Industries accepts no responsibility for the use of any of these signals or services for other than the stated purpose.

Calibration Reference Sheet	v
Unit Definitions and Conversions	vi
Unit of Measure Definitions	vi
Unit of Measure Conversions	vi
Chapter 1 Important Safety Information.....	1
Instructions for Wire Routing	2
Instructions for Hose Routing	3
Chapter 2 Introduction.....	7
AIM Command FLEX™ Features	7
Operation Modes	7
Operation Mode Features	8
Care and Use	10
Chapter 3 System Calibration	11
Initial Start Up and Calibration Wizard	11
Calibration Wizard	11
Functional Inspection	13
Nozzle Control Valve Function	13
Turn Compensation Feature	14
Sidekick Pro ICD Injection Initial Setup and Calibration	14
Injection Wizard and Calibration	14
Injection Wizard	15
Chapter 4 AIM Command FLEX™ Nozzle Control and Sidekick Pro ICD Setup	17
AIM Command FLEX™ Tools Menu Overview	17
Tools Menu Settings Definitions	18
Equipment Settings Tab	18
Disable Nozzle Control	20
System Settings Tab - User Settings	21
Wireless Control Mode	23
Group End Nozzles	24
System Settings Tab - Tank Fill	24
System Settings Tab - Alarm	25
System Settings Tab - Presets	26
System Settings Tab - Product Control	28
System Settings Tab - Pressure	29
Controller Diagnostics Information Tab	32
System Information Tab	34
Chapter 5 Operation	37
Operation Checklist	37
AIM Command FLEX™ Home Screen Definitions	37
Quick Access Softkeys	38
AIM Command FLEX™ Upper Home Screen	40

Table of Contents

AIM Command FLEX™ Lower Home Screen	43
Chapter 6 Tally Registers	47
Using Tally Registers	47
Resetting a Register	47
Tally Register Definitions	47
Task Tallies	48
Lifetime Tallies	48
Device Stats	48
Distance	48
Flow Rate Display	48
Area/Hour Display	48
Chapter 7 AIM Command FLEX™ Nozzle Control Valve Diagnostics	49
Nozzle Control Valve Diagnostic Definitions	49
Section Diagnostics Prompt	49
Individual Nozzle Diagnostics	50
Chapter 8 Troubleshooting	53
AIM Command FLEX™ Nozzle Control Valve Status	53
Nozzle Technical Specifications	54
Cable Troubleshooting	54
Troubleshooting NCV Cable Connections	54
Troubleshooting 19-Pin Boom Cable Connections	55
Troubleshooting Terminator Connections	56
Troubleshooting Flow Meter Cables	56
Diagnostic Trouble Code (DTC) List	58
General Troubleshooting	65
Appendix A Avoiding Skips with AIM Command FLEX™ Nozzle Control System	69
Overview	69
Recommendations for AIM Command FLEX™ Nozzle Control Operation	69
Causes of Skips using AIM Command FLEX™ Nozzle Control	70
Tip Selection and Application Speed Guide	72
Drift Control and Droplet Sizing	72
Application Speed Guide	74
Appendix B Calibration Values	79
Section Widths	79
Target Rate Calibration	79
Product Calibration Settings	80
Response Sensitivity	80
Deadband	80
Pressure Control Settings	80
Response Rate	80

Appendix C	Maintenance Schedule and Replacement Parts	81
	AIM Command FLEX™ Nozzle Control Valve Maintenance	81
	Nozzle Control Valve Maintenance Procedure	86
	aim Command FLEX™ Nozzle Control Valve Assembly Procedure	88
	System Testing	89
	Testing for Leaks	89
	Flow Meter Maintenance	89
	Recalibrating the Flow Meter	90
Appendix D	Cable and Connector Maintenance	93
	Power and Product Controller II ECU Harness Maintenance	93
	Boom Harness Connector Maintenance	93
Appendix E	Storage and Start-Up Checklist.....	97
	AIM Command FLEX™ Storage and Start-Up Checklist	97
	Preseason Cleaning and Flushing	97
	Start-Up Inspection	97
	Functional Inspection	98
	Overlap Control Adjustment	99
	Winterizing and Storing the System	99
Appendix F	AIM Command FLEX™ Flowchart.....	101
	AIM Command FLEX™ Flowchart	101
Appendix G	Remote Control and Diagnostics Application.....	107
	Remote Operation	107
	Diagnostics Application Operation	107
	Diagnostic Application Best Practices	107
	Mobile Application Screens	108

CALIBRATION REFERENCE SHEET

Record settings and calibration values used when programming the system in the fields below and keep this sheet for future reference.

GENERAL IMPLEMENT INFORMATION

UNITS	US (Acres)	SI (Hectares)	Nozzle Spacing		Boom Offset	
Speed Cal			Tip Size		Boom	

Section Widths (Boom Cal)			
1.	5.	9.	13.
2.	6.	10.	14.
3.	7.	11.	15.
4.	8.	12.	16.

TANK FILL SETTINGS

Tank Capacity		Low Tank Limit	
Fill Flow Meter Cal		Units	

PRODUCT CONTROL SETTINGS

Min. Pump PWM		Max. Pump PWM	
Standby Pump PWM		Pump PWM Frequency	
Minimum Nozzle PWM		(Flow) Meter Cal	
Units		Response Sensitivity	
Deadband			

PRESSURE SETTINGS

Response Rate		Min. Pressure	
Max. Pressure		0-250 psi or 0-150 psi	

UNIT DEFINITIONS AND CONVERSIONS

UNIT OF MEASURE DEFINITIONS

Abbreviation	Definition	Abbreviation	Definition
GPM	Gallons per Minute	dm	Decimeters
lit/min	Liters per Minute	m	Meter
dl/min	Deciliters per Minute	MPH	Miles per Hour
PSI	Pounds per Square Inch	km	Kilometers
kPa	Kilopascal	km/h	Kilometers per Hour
GPA	Gallons per Acre	US	Volume per Acre
lit/ha	Liters per Hectare	SI	Volume per Hectare
ml/ha	Milliliters per Hectare	TU	Volume per 1,000 Square Feet
GPK	Gallons per 1,000 Square Feet	[]	Metric Numbers
mm	Millimeters	lb/acre	Pounds per Acre
cm	Centimeters	kg/ha	Kilograms per Hectare

UNIT OF MEASURE CONVERSIONS

To convert the meter cal value into the selected unit of measure, divide the original number printed on the flow meter label by the desired conversion value.

Fluid Ounces Conversion Formula	Liters Conversion Formula	Pounds Conversion Formula
$\frac{\text{Original Meter Cal}}{128}$	$\frac{\text{Original Meter Cal}}{3.785}$	$\frac{\text{Original Meter Cal}}{\text{Weight of One Gallon of}}$

Liquid	Area
--------	------

- | | |
|---|--|
| <ul style="list-style-type: none"> • 1 U.S. gallon = 128 fluid ounces • 1 U.S. gallon = 3.785 liters • 1 U.S. gallon = 0.83267 imperial gallons • 1 U.S. gallon = 8.34 pounds (water) • 1 U.S. gallon = 10.67 pounds (28% N) • 1 U.S. gallon = 11.06 pounds (32% N) • 1 U.S. gallon = 11.65 pounds (10-34-0) | <ul style="list-style-type: none"> • 1 square meter = 10.764 square feet • 1 hectare = 2.471 acres or 10,000 square meters • 1 acre = 0.405 hectares or 43,560 square feet • 1 square mile = 640 acres or 258.9 hectares |
|---|--|

Length	Pressure
--------	----------

- | | |
|--|---|
| <ul style="list-style-type: none"> • 1 millimeter (mm) = 0.039 inches • 1 centimeter (cm) = 0.393 inches • 1 meter (m) = 3.281 feet • 1 kilometer (km) = 0.621 miles • 1 inch = 25.4 mm or 2.54 cm • 1 mile = 1.609 km | <ul style="list-style-type: none"> • 1 psi = 6.89 kPa • 1 kPa = 0.145 psi |
|--|---|

CHAPTER

1

IMPORTANT SAFETY INFORMATION

NOTICE

Read this manual and the operation and safety instructions included with the implement and/or controller carefully before installing the Case IH AIM Command FLEX™™ control system.

- Follow all safety information presented within this manual.
- If you require assistance with any portion of the installation or service of your Case IH equipment, contact a local Case dealer for support.
- Follow all safety labels affixed to the system components. Be sure to keep safety labels in good condition and replace any missing or damaged labels. To obtain replacements for missing or damaged safety labels, contact a local Case dealer.

When operating the machine after installing the Case IH AIM Command FLEX™ control system:

- Be alert and aware of surroundings.
- Do not operate any agricultural equipment while under the influence of alcohol or an illegal substance.
- Determine and remain a safe working distance from other individuals. The operator is responsible for disabling product control when a safe working distance has diminished.
- Disable the system prior to starting any maintenance work on the machine or parts of the control system.



WARNING

AGRICULTURAL CHEMICAL SAFETY

- Always follow safety labels and instructions provided by the chemical manufacturer or supplier.
- Always wear appropriate personal protective equipment as recommended by the chemical and/or equipment manufacturer.
- When storing unused agricultural chemicals:
 - Store agricultural chemicals in the original container and do not transfer chemicals to unmarked containers or containers used for food or drink.
 - Store chemicals in a secure, locked area away from human and livestock food.
 - Keep children away from chemical storage areas.
- Fill, flush, calibrate, and decontaminate chemical application systems in an area where runoff will not reach ponds, lakes, streams, livestock areas, gardens, or populated areas.
- Avoid inhaling chemical dust or spray particulate and avoid direct contact with any agricultural chemicals. Seek immediate medical attention if symptoms of illness occur during, or soon after, use of agricultural chemicals, products, or equipment.
- After handling or applying agricultural chemicals:

- Thoroughly wash hands and face after using agricultural chemicals and before eating, drinking, or using the rest room.
- Thoroughly flush or rinse equipment used to mix, transfer, or apply chemicals with water after use or before servicing any component of the application system.
- Follow all federal, state, and local regulations regarding the handling, use, and disposal of agricultural chemicals, products, and containers. Triple-rinse and puncture or crush empty containers before disposing of them properly. Contact a local environmental agency or recycling center for additional information.

CAUTION

ELECTRICAL SAFETY

- Always make sure that the power leads are connected to the correct polarity as marked. Reversing the lead wires could cause severe damage to electrical components and equipment.
- Connect the power cable last.
- Disconnect the AIM Command FLEX™ nozzle control system from the vehicle battery before jump-starting the vehicle.
- Disconnect the AIM Command FLEX™ nozzle control system from the vehicle battery before welding any component of the implement.

INSTRUCTIONS FOR WIRE ROUTING

The word “harness” is used to mean all electrical leads and cables, bundled and unbundled. When installing harness, secure it at least every 30 cm (12in) to the frame. Follow existing harness as much as possible and use these guidelines:

Harness should not contact or be attached to:

- Lines and hoses with high vibration forces or pressure spikes
- Lines and hoses carrying hot fluids beyond harness component specifications

Avoid contact with any sharp edge or abrading surfaces such as, but not limited to:

- Sheared or flame cut edges
- Edges of machined surfaces
- Fastener threads or cap screw heads
- Ends of adjustable hose clamps
- Wire exiting conduit without protection, either ends or side of conduit
- Hose and tube fittings

Routing should not allow harnesses to:

- Hang below the unit
- Have the potential to become damaged due to exposure to the exterior environment. (i.e. tree limbs, debris, attachments)
- Be placed in areas of or in contact with machine components which develop temperatures higher than the temperature rating of harness components
- Wiring should be protected or shielded if it needs to route near hot temperatures beyond harness component specifications

Harnessing should not have sharp bends

Allow sufficient clearance from machine component operational zones such as:

- Drive shafts, universal joints and hitches (i.e. 3-point hitch)
- Pulleys, gears, sprockets
- Deflection and backlash of belts and chains
- Adjustment zones of adjustable brackets
- Changes of position in steering and suspension systems
- Moving linkages, cylinders, articulation joints, attachments
- Ground engaging components

For harness sections that move during machine operation:

- Allow sufficient length for free movement without interference to prevent: pulling, pinching, catching or rubbing, especially in articulation and pivot points
- Clamp harnesses securely to force controlled movement to occur in the desired harness section
- Avoid sharp twisting or flexing of harnesses in short distances
- Connectors and splices should not be located in harness sections that move

Protect harnesses from:

- Foreign objects such as rocks that may fall or be thrown by the unit
- Buildup of dirt, mud, snow, ice, submersion in water and oil
- Tree limbs, brush and debris
- Damage where service personnel or operators might step or use as a grab bar
- Damage when passing through metal structures

IMPORTANT: Avoid directly spraying electrical components and connections with high pressure water. High pressure water sprays can penetrate seals and cause electrical components to corrode or otherwise become damaged. When performing maintenance:

- Inspect all electrical components and connections for damage or corrosion. Repair or replace components, connections, or cable as necessary.
- Ensure connections are clean, dry, and not damaged. Repair or replace components, connections, or cable as necessary.
- Clean components or connections using low pressure water, pressurized air, or an aerosol electrical component cleaning agent.
- Remove visible surface water from components, connections, or seals using pressurized air or an aerosol electrical component cleaning agent. allow components to dry completely before reconnecting cables.

INSTRUCTIONS FOR HOSE ROUTING

The word "hose" is used to mean all flexible fluid carrying components. Follow existing hoses as much as possible and use these guidelines:

Hoses should not contact or be attached to:

- Components with high vibration forces
- Components carrying hot fluids beyond component specifications

Avoid contact with any sharp edge or abrading surfaces such as, but not limited to:

- Sheared or flame cut edges
- Edges of machined surfaces
- Fastener threads or cap screw heads
- Ends of adjustable hose clamps

Routing should not allow hoses to:

- Hang below the unit
- Have the potential to become damaged due to exposure to the exterior environment. (i.e. tree limbs, debris, attachments)
- Be placed in areas of or in contact with machine components which develop temperatures higher than the temperature rating of hose components
- Hoses should be protected or shielded if it needs to route near hot temperatures beyond hose component specifications

Hoses should not have sharp bends

Allow sufficient clearance from machine component operational zones such as:

- Drive shafts, universal joints and hitches (i.e. 3-point hitch)
- Pulleys, gears, sprockets
- Deflection and backlash of belts and chains
- Adjustment zones of adjustable brackets
- Changes of position in steering and suspension systems
- Moving linkages, cylinders, articulation joints, attachments
- Ground engaging components

For hose sections that move during machine operation:

- Allow sufficient length for free movement without interference to prevent: pulling, pinching, catching or rubbing, especially in articulation and pivot points
- Clamp hoses securely to force controlled movement to occur in the desired hose section
- Avoid sharp twisting or flexing of hoses in short distances

Protect hoses from:

- Foreign objects such as rocks that may fall or be thrown by the unit
- Buildup of dirt, mud, snow, ice, submersion in water and oil
- Tree limbs, brush and debris
- Damage where service personnel or operators might step or use as a grab bar
- Damage when passing through metal structures
- High pressure wash

IMPORTANT: Avoid directly spraying electrical components and connections with high pressure water. High pressure water sprays can penetrate seals and cause electrical components to corrode or otherwise become damaged. When performing maintenance:

- Inspect all electrical components and connections for damage or corrosion. Repair or replace components, connections, or cable as necessary.
- Ensure connections are clean, dry, and not damaged. Repair or replace components, connections, or cable as necessary.

- Clean components or connections using low pressure water, pressurized air, or an aerosol electrical component cleaning agent.
- Remove visible surface water from components, connections, or seals using pressurized air or an aerosol electrical component cleaning agent. Allow components to dry completely before reconnecting cables.

The AIM Command FLEX™ Nozzle Control System is designed to provide PWM product rate and nozzle control via an ISOBUS universal terminal (UT). Adding the AIM Command FLEX™ control system to an existing ISOBUS product control system will allow a machine operator to monitor and control product application rate and pressure independently directly from the UT without additional displays, controllers, or consoles.

This document provides information regarding the following aspects of the AIM Command FLEX™ nozzle control system:

- Initial Setup and Navigation
- Calibration
- AIM Command FLEX™ System Operation
- AIM Command FLEX™ Operation When Used With Direct Injection
- Updating AIM Command FLEX™ Components

NOTE: Prior to using the AIM Command FLEX™ control features with any UT display, the AIM Command FLEX™ Electronic Control Unit (Product Controller II ECU) must be calibrated for the control system. Refer to Chapter 3, *System Calibration*, for assistance with completing the initial calibration wizard.

This manual assumes that the required control hardware is already installed on supported equipment and is properly connected. Contact a local Case IH dealer for additional information on supported equipment configurations.

AIM COMMAND FLEX™ FEATURES

OPERATION MODES

The AIM Command FLEX™ control system can be configured in several different modes to fit the application.

TABLE 1. Operation Mode Features

	Standard	VP	High Flow	High Flow VP	On/Off	Bypass	Tiered Nozzle
Direct Injection	Yes	Yes	Yes	Yes	Yes	Yes	Yes
Wireless Diagnostics	Yes	Yes	Yes	Yes	Yes	Yes	Yes
Flow Control	Yes	Yes	Yes	Yes	Yes	Yes	Yes
Pressure Control	Yes	No	Yes	No	No	No	No
Wheel Tracks	Yes	Yes	Yes	Yes	No	No	No
Turn Compensation	Yes	Yes	Yes	Yes	No	No	No
Virtual Sections	Yes	Yes	No	No	Yes	No	No
Individual Nozzle Control	Yes	No	No	No	Yes	No	No

Standard Mode. The AIM Command FLEX™ system will control to a target flow rate and target pressure. This is the most common sprayer setting.

Variable Pressure (VP) Mode. This mode will control to a target-flow rate and target nozzle duty cycle by varying the pressure. This is useful for scenarios where pressure is not a priority (i.e. fertilizer application).

High Flow Mode. This mode allows both a conventional nozzle and a AIM Command FLEX™ nozzle to run simultaneously to achieve higher flow rates.

High Flow VP Mode. This mode allows both a conventional nozzle and a NCV to run simultaneously to achieve higher flow rates. High Flow VP varies pressure and nozzle duty cycle to control the target flow rate.

On/Off Mode. The AIM Command FLEX™ System will hold the nozzle valve 100% open during application or fully closed when not applying. This mode can be used with air induction tips and stream bars.

Bypass (Conventional) Mode. The AIM Command FLEX™ system will control to a target flow, but the nozzle control valve is disabled. A secondary flow outlet must be made available at each tip.

OPERATION MODE FEATURES

DIRECT INJECTION

The Direct Injection system is designed to provide efficient and accurate application of liquid chemicals applied from an injection module. By using a separate injection module or tank, the system eliminates mixing chemicals in the tank, reduces chemical waste, and simplifies equipment care and maintenance. Connect up to five injection systems to the Viper 4 and ISOBUS to control the whole system through the AIM Command FLEX™ user interface screens on the universal terminal. Select a high flow injection system to control a wide range of chemical flow rates from 5 - 200 oz/min. Select a low flow injection system to provide chemical flow rates from 1 - 40 oz/min. Refer to the "AIM Command FLEX™ Nozzle Control and Sidekick Pro ICD Setup" section on page 17 for additional information on Direct Injection configuration.

WIRELESS DIAGNOSTIC CONTROL

Wireless diagnostic control allows the user to control the system and perform diagnostics through a personal mobile device such as a tablet or smart phone or by using a wireless remote. The user can turn on and off boom sections, turn the pump on or off, and view real-time system information for troubleshooting or demonstration purposes without having to leave the cab. A Bluetooth low energy (BLE) compatible device is required.

PRESSURE NOZZLE CONTROL

The AIM Command FLEX™ nozzle control system provides the same spray pattern and coverage as conventional spray systems. Pressure based nozzle control allows the operator to maintain the same target pressure and operate over a larger application speed or flow range while maintaining droplet size. This may help manage spray drift and allow the equipment to operate in higher winds. Better droplet control also provides more accurate field application and better rate control at lower target flow rates than the flow meter can detect.

WHEEL TRACKS

The wheel track feature allows the user to increase the flow rate of eight nozzles anywhere on the boom by up to 30% over the rest of the nozzles in order to maintain optimal coverage in the turbulent air conditions behind vehicle wheels. If a valid profile is selected, this can be done by pressing on of the four wheel tracks buttons that have programmed nozzles. With the push of a button, reset the nozzles back to their original flow rate or increase the flow on other nozzles.

TURN COMPENSATION

Conventional application systems provide a uniform rate across the boom or implement width. This functionality works well in large field areas with straight swaths to ensure even coverage during application.

But what if the field you are working is not square? What if the field you are working has numerous waterways, tree lines, terraces, or other obstacles that require the equipment operator to follow the curvature of the feature during application? When applying around curves and corners, traditional application systems do not compensate for the speed variance observed at the inner and outer ends of the boom or implement. The difference in coverage across the large and ever expanding sizes of application equipment on the market today can result in large areas of under or over application and will reduce the application efficiency, and negatively impact yields.

Turn compensation, standard with the AIM Command FLEX™ nozzle control system, helps ensure an even flow rate while applying around curves and corners, even when operating with the largest of application equipment sizes on the market. Turn compensation automatically reduces or stops the flow rate of nozzles toward the inside of the curve, while increasing the flow rate at the outside, to help ensure an even, efficient application to address crop conditions, minimize crop damage, and improve yields. Refer to the *Tools Menu Settings Definitions* section on page 18 for additional information on Turn Compensation.

VIRTUAL SECTIONS

Whether one section or ten, the AIM Command FLEX™ Virtual Section feature will automatically divide the boom sections into as many as 36 virtual sections. This feature is standard on all AIM Command FLEX™ systems and increases boom section resolution. When combined with automatic section control on the task controller, this will increase spraying efficiency, enhance product mapping, and save time and input costs.

INDIVIDUAL NOZZLE CONTROL

If your application control system includes a Viper 4+, unlock the individual nozzle control feature for the finest product application resolution and accuracy. This mode turns each nozzle into an individual boom section and offers maximum product savings. Contact a local Case IH dealer for more information.

CARE AND USE

Always follow equipment manufacturer's recommended maintenance procedures for storing equipment. Perform the following maintenance procedures before storing equipment with the AIM Command FLEX™ nozzle control system:

1. Empty product from the chemical supply tank and flush the application system with water or an approved tank cleaner following the machine manufacturer's recommended procedures.
2. Remove hardened chemical residues or build up by flushing the system with soap and water.
3. Prime the system plumbing with a 50% water and automotive antifreeze mixture to prevent freezing of NCV components. Freezing will result in damage to the AIM Command FLEX™ system and other plumbing components on the system.

Refer to Appendix C, *Maintenance Schedule and Replacement Parts*, for additional assistance with maintaining the AIM Command FLEX™ nozzle control valves.

Calibration Reference Sheet section on page v

INITIAL START UP AND CALIBRATION WIZARD

The calibration wizard must be completed the first time that the AIM Command FLEX™ system is powered up on the ISOBUS network or if the default system settings are reset. The calibration wizard allows the operator to quickly configure the required AIM Command FLEX™ system and nozzle control valves detected by the AIM Command FLEX™ Product Controller II (PCII) ECU.

Review the following sections for assistance with completing the calibration wizard for the AIM Command FLEX™ nozzle control system.

NOTE: Refer to the UT Operation Manual for other necessary setup or calibration required before operating the AIM Command FLEX™ nozzle control system or features.

TRANSFER UNIVERSAL TERMINALS

If more than one UT is detected on the system, a Transfer UT softkey will be displayed. Use this button to switch the working set to an alternate UT at any time.



Transfer UT

If the working set is not available on the desired UT, check the other displays and use the Transfer UT softkey to transfer the PCII working set.

By default, the PCII working set will load to the first UT to come online when starting up the ISOBUS. When using the Transfer UT softkey, the PCII working set will automatically load to the last UT selected unless the system requires calibration or the last UT cannot be detected within two minutes.

CALIBRATION WIZARD

To access the AIM Command FLEX™ calibration wizard during the initial system start up:

1. Turn power on to the UT and allow the display to power up and initiate the ISOBUS system.

NOTE: If properly connected and powered, the UT will automatically detect the AIM Command FLEX™ Product Controller II ECU.

If the Product Controller II ECU is not detected by the display terminal, troubleshoot the AIM Command FLEX™ Product Controller II ECU and restart the system. Refer to "Troubleshooting" on page 53 for assistance with connection issues. Contact a local New Holland dealer for additional troubleshooting assistance if the Product Controller II ECU is still not detected.

2. Once the AIM Command FLEX™ Product Controller II ECU is detected, the AIM Command FLEX™ Menu button will display in the UT Menu.
3. Touch the Menu button to access the AIM Command FLEX™ nozzle control system user interface.
4. The first time that the AIM Command FLEX™ system is started on the UT, or if the default settings have been reset, the first calibration wizard prompt will be displayed.

MACHINE MAKE AND BOOM SETUP

Select the correct machine make and the boom profile to automatically load machine specific settings.

NOZZLE SETUP AND TIP SIZE

The following steps are intended to assist with entering the nozzle calibration information required for the AIM Command FLEX™ system.

1. Verify the total number of Nozzle Control Valves (NCVs) on the AIM Command FLEX™ system matches the NCVs detected by the AIM Command FLEX™ Product Controller II ECU.

NOTE: If the total number of nozzles displayed does not match the expected number of nozzle control valves connected to the system refer to Chapter 8, *Troubleshooting* for assistance with the AIM Command FLEX™ nozzle control valve circuit.

2. The AIM Command FLEX™ Product Controller II ECU will attempt to detect the number of nozzle control valves connected to the left boom (center of the boom to the tip of the left boom) circuit. Check the displayed value against the actual number of valves connected to the left boom circuit. If necessary, select the Nozzle Count field and enter the appropriate number of nozzle control valves connected to the left boom circuit.
3. To bypass nozzle configuration and operate the system without the AIM Command FLEX™ Nozzle Control Valves, press the Skip Nozzle Setup button. If the Nozzle Control Valves are installed on the machine, the NCVs will remain closed and must be manually bypassed at the boom by opening a secondary flow outlet, or removed from the machine to apply product. The system will then operate as a conventional sprayer with the AIM Command FLEX™ Product Controller II ECU.
4. Select the Next button to continue to the Tip Size prompt.
5. Select the Tip Size field and use the available options to select the orifice size of the tips currently installed on the nozzle bodies.
 - NCV is the tip connected to the AIM Command FLEX™ valve. The Bypass Tip is for secondary tips at each nozzle.
 - If no tips are installed and liquid fertilizer is being applied, select NA as the tip size.
6. Select the Next button to proceed to the Nozzle Indexing prompt.

AUTOMATIC NOZZLE INDEXING

The automatic nozzle indexing process allows the AIM Command FLEX™ system to automatically configure the location of each nozzle control valve on the left and right boom circuits and may detect issues with system connection or nozzle setup.

1. When prompted, select the Next button to begin the auto-indexing process.
2. AIM Command FLEX™ will begin indexing nozzle control valves from the center of the implement boom and move out to the end of the left boom. The indexing process automatically repeats for the right boom circuit, starting from the center and working towards the end of the boom. If an error is detected on either the left or right boom circuits, the AIM Command FLEX™ Product Controller II ECU will halt the indexing process and prompt the machine operator to correct the error before continuing with the calibration wizard. If an error occurs, troubleshoot the issue and press retry.

FENCE ROW SETUP

1. The Fence Row Setup prompt will display once the automatic indexing process completes.
2. Enable the fence row option if fence row valves are connected to the system.
3. Select the Next button to continue to the Boom Offset prompt.

BOOM OFFSET

1. Select the Boom Offset.
2. Enter the distance the boom is offset from the rear axle.
3. Press Next to continue to the Meter Cal prompt.

METER CAL AND UNITS

1. Select the Meter Cal field and enter the calibration value for the flow meter used to monitor the AIM Command FLEX™ system product flow.
2. Select the units field and select the units used by the flow meter to monitor flow.

NOTE: Raven flow meters use a meter cal in pulses per 10 gallons [37.9 L]. Other flow meters may use different meter cal rates.

3. Select the Next button to proceed to complete calibration.

FUNCTIONAL INSPECTION

Refer to the following sections for assistance with validating that the AIM Command FLEX™ nozzle control system has been installed properly:

NOZZLE CONTROL VALVE FUNCTION

To verify that the AIM Command FLEX™ nozzle control system is functioning properly after installation:

1. Flush the main product tank and boom plumbing with clean water, and verify the tank contains at least 100 gallons [379 L] of clean water.
2. Park the equipment in an area with enough space to unfold the booms and allows for visual inspection of the spray pattern from a moderate distance (e.g. 20 ft [6.1 m]).
3. Set the AIM Command FLEX™ nozzle control system to manual mode, and set both the pump PWM and nozzle PWM to 50%.
4. If necessary, open the tank valve.
5. If present, turn on the machine's switch then press the on-screen pump soft key to engage the pump.
6. Toggle all section switches and the master switch.

	<p>WARNING</p> <p>Equipment will begin spraying. Avoid inhaling spray particulate and avoid direct contact with any agricultural chemicals. Seek immediate medical attention if symptoms of illness occur during, or soon after, use of agricultural chemicals, products, or equipment.</p>
---	--

7. While maintaining a safe distance away from any spray drift, visually check that all nozzle control valves are pulsing with a uniform pattern. Adjacent nozzle control valves should alternate pulsing. If adjacent spray tips are pulsing at the same time, refer to Chapter 8, *Troubleshooting*, for additional assistance.

8. On the UT, set nozzle PWM to 0% and Pump PWM to about 30% to close the nozzle control valves and maintain a safe pressure in the boom.
9. Visually check that none of the nozzles are spraying or dripping. Refer to *Testing for Leaks* section on page 89 for additional assistance and troubleshooting if leaks are observed.

TURN COMPENSATION FEATURE

To verify the Turn Compensation feature is enabled and operating:

NOTE: Complete the procedure outlined in the *Nozzle Control Valve Function* section on page 13 to validate the nozzle control valve function prior to performing the following procedure.

Turn Compensation is automatically calibrated during the calibration wizard. If the feature is not operating as described below, refer to the "Turn Compensation Calibration" section on page 22 for assistance with calibrating the turn compensation feature if necessary.

1. Move the implement to an open area where the equipment may be driven in quick, tight turns.
2. Verify that the turn compensation feature is enabled.
3. Set the system to automatic mode and toggle the section and master switches to the on positions. Refer to Chapter 5, *Operation* for additional assistance with operation of the nozzle control system.
4. While driving at a speed between 5 and 10 mph [8 and 16 km/h] and maintaining a safe working distance, observe the inner-most and outer-most spray tips while the implement is turning sharply.

NOTE: The nozzle PWM percent value may also be used to monitor the operation of nozzle control valves across the spray boom. Refer to Chapter 7, *AIM Command FLEX™ Nozzle Control Valve Diagnostics*, for additional assistance with on-screen nozzle control valve diagnostics.

While turning, the nozzle control valves toward the outside of the corner should begin to output a higher flow rate (higher PWM percent), while valves toward the inside of the corner should begin to output a reduced flow rate (lower PWM percent) or may shut off. NCV diagnostics and performance can be seen in the Performance Indicator on the PCII home screen or in the individual NCV diagnostics pages. The difference between inner and outer flow rates will vary depending on machine speed, turn rate, and implement width. Turn compensation can also be observed on the Diagnostics Info page. Product Controller II ECU Yaw Rate will be zero while stationary. If turning clockwise, the Product Controller II ECU Yaw Rate will be positive, if turning counter clockwise, the Product Controller II ECU Yaw Rate will be negative.

5. If the operator is able to observe a difference in the spray pulsing, or the on-screen PWM percent, the turn compensation feature is working correctly. If there is no difference between the PWM percent values across the implement width, recalibrate the turn compensation feature and repeat the test.

SIDEKICK PRO ICD INJECTION INITIAL SETUP AND CALIBRATION

INJECTION WIZARD AND CALIBRATION

The injection wizard must be completed the first time that the Sidekick Pro ICD system is powered up on the ISOBUS network or if the default system settings are reset. The injection wizard allows the operator to quickly assign the detected devices on the ISOBUS to the correct product channel.

Review the following sections for assistance with completing the injection wizard for the Sidekick Pro ICD Direct Injection system.

NOTE: Refer to the UT operation manual for additional setup, operation, or calibration information before operating the Sidekick Pro ICD Direct Injection system or features.

INJECTION WIZARD

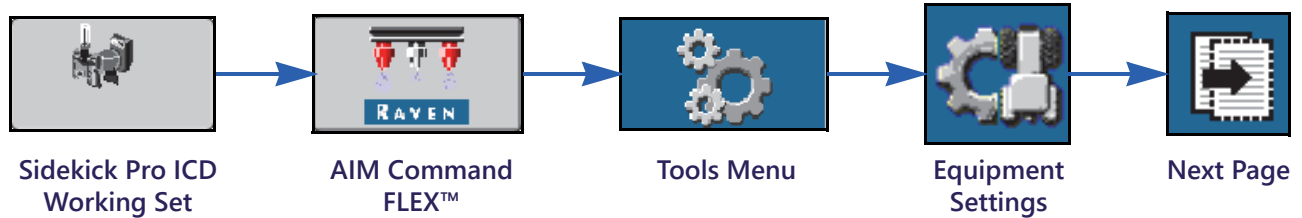

1. Turn the UT power on and allow the display to power up and initiate the ISOBUS system.

NOTE: If properly connected and powered, the UT will automatically detect the Sidekick Pro ICD Product Controller II ECU. If the Product Controller II ECU is not detected by the display terminal, troubleshoot the Sidekick Product Controller II ECU and restart the system. Refer to “Troubleshooting” section on page 53 for assistance with connection issues. Contact a local Case IH dealer for additional troubleshooting assistance if the Product Controller II ECU is still not detected.

2. Once the Sidekick Pro ICD Product Controller II ECU is detected, the Sidekick Pro ICD Menu button will display in the UT Menu.
3. Press the AIM Command FLEX™ Menu button.
4. Select the Tools Menu.
5. Press the Equipment Settings tab.
6. Select the Injection Wizard.
7. Locate the Sidekick Pro ICD Product Controller II ECU serial number. The serial number is typically located on the front or top of the direct injection pump.
8. Assign the desired Sidekick Pro ICD Product Controller II ECU to the desired product channel.

FIGURE 1. Injection Wizard Serial Number Assignment



9. Press the Next softkey.
10. Set the desired Target Rate for each Sidekick Pro ICD Product Controller II ECU.

FIGURE 2. Product Controller II ECU Desired Target Rate

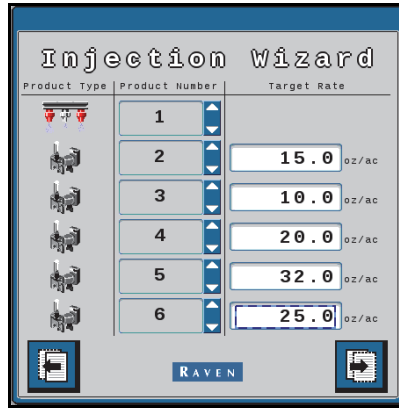

NOTE: For more information on setup and operation of Sidekick Pro ICD pumps, refer to the Sidekick Pro operation manual.

AIM COMMAND FLEX™ TOOLS MENU OVERVIEW

System settings and information are displayed in four categories which may be viewed by selecting the tabs displayed along the top of the Tools Menu.

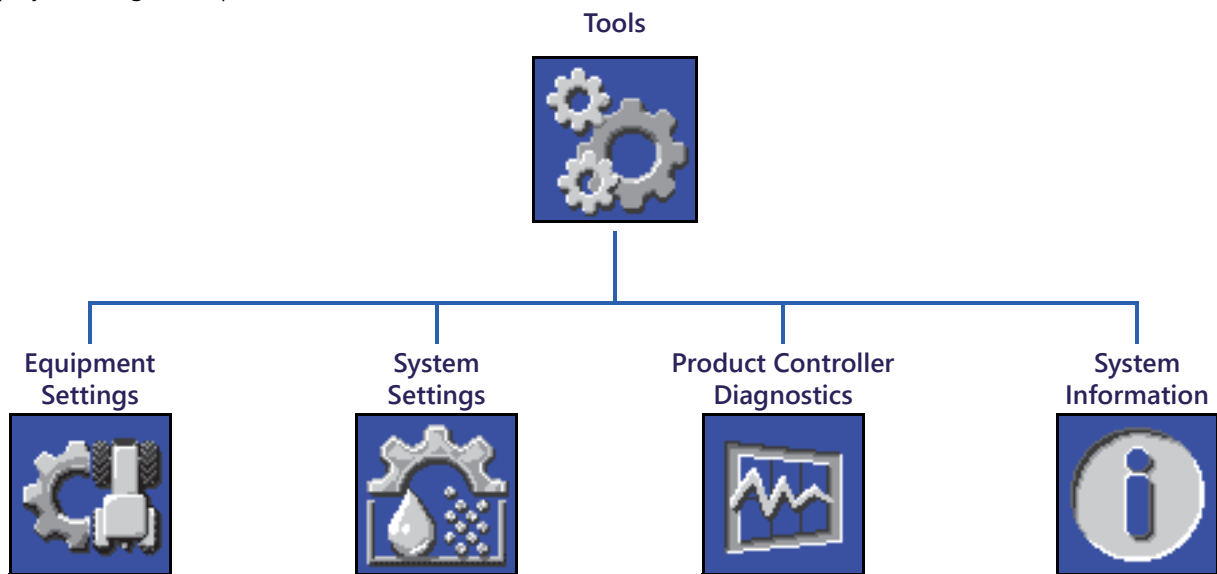

NOTE: If needed, press the help button on any screen for additional information.

Equipment Settings. Access the equipment settings to change the nozzle control mode, enable virtual section control, select tip sizes, verify section widths, or to restart the injection or AIM Command FLEX™ System Calibration wizards.



System Settings. Adjust the following setting and feature categories for the main product or any of the injection products:

- User Settings
- Tank Fill Settings
- Alarm Settings
- Presets Settings
- Product Control Settings
- Pressure Settings

Product Controller Diagnostics. Access system information which may provide advanced diagnostic and control function information for the AIM Command FLEX™ system.

System Information. Select to view details of the AIM Command FLEX™ Product Controller II ECU such as hardware and software version numbers, run-time, or task controller connectivity.

TOOLS MENU SETTINGS DEFINITIONS

EQUIPMENT SETTINGS TAB

To access the Equipment Settings Menu:

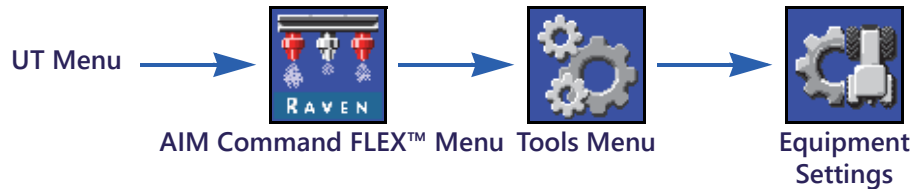

1. Open the UT Menu and select the AIM Command FLEX™ Menu button.
2. Select the Tools Menu softkey along the right side of the display.
3. Select the Equipment Settings tab along the top of the display. The following settings may be viewed or modified:

Page 1

- Nozzle Control Mode
- Section Control Mode
- Boom
- NCV Tip Size
- Bypass Tip Size
- Calibrate NCVs
- Injection Wizard

Page 2

- Total Width
- Section Width
- Switch Mapping
- Flow Meter Cal
- Pressure Sensor
- Boom Offset
- Total Nozzles
- Valve Type
- Fence Rows
- Application Type
- Nozzle Spacing

NOZZLE CONTROL MODE

Select the desired Nozzle Control Mode (Standard, Bypass, On/Off, High Flow, High Flow VP, or VP). Refer to the mode descriptions in the *Operation Modes* section on page 7.

NOTE: Only select bypass mode if the nozzle bodies on the implement are set to bypass the AIM Command FLEX™ nozzle control valves during operation.

The nozzle control mode can only be changed outside of a job. If the user desired to change modes in the field: close the job, change the mode, and then re-open the job.

SECTION CONTROL MODE

Use the Section Control drop down field to select the section control mode (Virtual, Boom Valve, or HD).

- Basic section control will split the boom based on the number of sections that were entered in the calibration wizard. AccuBoom will open/close the section valves as well as NCVs.
- Virtual section control divides the existing sections into a maximum of 16 smaller sections with the smallest sections at the boom tips. AccuBoom will only open/close NCVs. A Master Switch is required to open/close the section valves.

- AIM Command FLEX™ HD section control will handle each nozzle like an individual section. Requires Viper 4 and HD unlock. AccuBoom will only open/close NCVs. A Master Switch is required to open/close the section valves.

NOTE: The section control mode can only be changed outside of a job. The system will default to Virtual section control if HD section control is not unlocked.

TIP SIZE OPTION

Use the tip size drop down field to select the size of orifice on the spray boom. This setting is used to assist with the application information displayed for the equipment operator during field applications. This setting will affect the speed range, the rate and pressure gauge displays, and ensure the nozzle control system accurately monitors the application of product during field operations. Entering a NCV tip size is mandatory but the bypass tip size is optional depending on the machine nozzle configuration.

REBOOT MAIN ECU

Select this button to restart the Product Controller II or Hawkeye ECU.

INJECTION WIZARD

Select the Injection Wizard button to re-assign the Sidekick Pro ICD injection products. Refer to *Injection Wizard* section on page 15 for additional assistance with completing the setup of the Sidekick Pro ICD direct injection pumps.

NOTE: Restarting injection wizard does not reset the Sidekick Pro ICD system default settings. Refer to *System Information Tab* section on page 34 for additional information on restoring default system settings.

TOTAL AND SECTION WIDTH DISPLAYS

Total Width. The total width value displays the sum of the currently programmed section widths.

Section Widths. The widths of individual sections configured for the AIM Command FLEX™ nozzle control system will be displayed below the total width.

NOTE: Restart the calibration wizard to adjust or modify the section widths or the total width of the implement.

Switch Mapping. Sections mapped to a compatible switch box for manual section control will display using different color section width displays. Touch the Help icon on the Equipment Settings prompt to view a switch map legend.

NOTE: The AIM Command FLEX system automatically configures the Total Width, Section Width, and Switch Mapping when a Machine Make and Boom profile are selected in the Calibration Wizard. An ISOBUS boom interface/speed sense ECU, Product Controller II ECU, Raven ISOBUS switch box, or a bridge ECU must be connected with the AIM Command FLEX™ system. To configure custom switch mapping, restart the calibration wizard by resetting Defaults. Next, select the proper Machine Make, select a custom profile, and follow the on screen prompts for assistance with mapping sections to switch box functions during the calibration wizard.

FLOW METER CAL

Flow meter cal shows the current calibration number for the installed flow meter.

PRESSURE SENSOR

Pressure Sensor shows the current allowable pressure range for the installed pressure sensor.

BOOM OFFSET

Boom Offset displays the set offset distance from the boom to the rear axle.

TOTAL NOZZLE COUNT DISPLAY

The number of nozzles detected on the AIM Command FLEX™ nozzle control bus during the calibration wizard will be displayed in this field. If the nozzle count does not match the expected number of nozzles connected to the system, troubleshoot the nozzle control valve bus and restart the calibration wizard. Refer to Chapter 8, *Troubleshooting*, for additional troubleshooting assistance.

VALVE TYPE

Displays the valve type selected during machine configuration.

FENCE ROWS DISPLAY

If fence rows are enabled, the operator may use the left and right fence row switches to toggle fence row valves on or off during field applications. Restart the calibration wizard to change this setting.

NOTE: To allow the system to control fence row valves, the valves must be connected to the boom cable connections. Refer to the AIM Command FLEX™ installation manual provided with the nozzle control kit for additional assistance with the system installation and connection.

APPLICATION TYPE

Displays the Application Type selected during machine configuration.

NOZZLE SPACING DISPLAY

The nozzle spacing measurement set during the machine configuration is displayed in this field. This value, multiplied by the total nozzle count should equal the total width value.

DISABLE NOZZLE CONTROL

The AIM Command FLEX™ nozzle control system allows the operator to disable the nozzle control system during an application to allow for the use of a secondary set of tips.

NOTE: When nozzle control is disabled, the AIM Command FLEX™ nozzle control valves will remain closed.

Be sure to open manual shut off valves on each nozzle body for the appropriate tip when AIM Command FLEX™ nozzle control features are disabled.

If Nozzle Control Valves are installed on the machine, the NCVs must be manually bypassed at the boom or removed for the machine to operate properly when nozzle control is disabled. The system will then operate as a conventional sprayer with the AIM Command FLEX™ Product Controller II ECU.

NOTE: The nozzle control mode can only be changed outside of a job. To change modes in a field: close the job, change the mode, and open the job again.

To disable nozzle control:

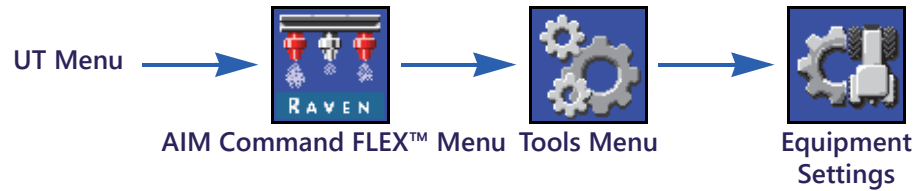

1. Open the UT Menu and select the AIM Command FLEX™ Menu button.
2. From the home screen, select the Tools Menu softkey along the right side of the display.
3. Select the Equipment Settings tab along the top of the display.

Select the Bypass option in the Nozzle Control Mode dropdown menu.

SYSTEM SETTINGS TAB - USER SETTINGS

To access the User Settings Menu:

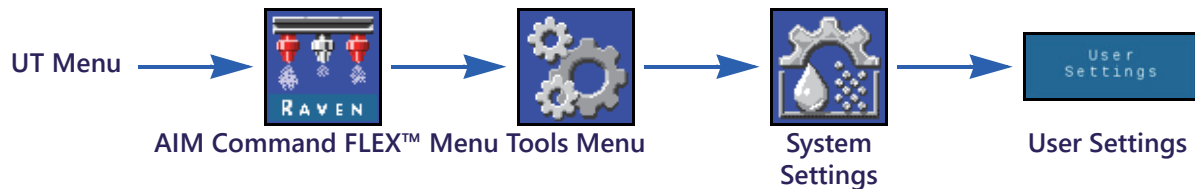

1. Open the UT Menu and select the AIM Command FLEX™ Menu button.
2. From the home screen, select the Tools Menu softkey along the right side of the display.
3. Select the System Settings tab along the top of the display.
4. Select the User Settings button. The following settings may be viewed or modified:

- Display Smoothing
- External/RX Control
- Enable Turn Compensation
- Override Seconds
- NCV Performance
- Wireless Control Mode
- Auto Section Control
- PWM High Side Drive
- Calibrate Turn Compensation
- Enable Wireless Control
- Speed Cal
- Group End Nozzles

DISPLAY SMOOTHING

Enable Display Smoothing to display target rate as actual rate when the rate is within 10% of the target rate. Actual rate will be displayed if the rate controller does not reach control deadband within ten seconds.

AUTO SECTION CONTROL

Allows section control in reference to coverage maps. When enabled, section control will automatically turn off an active section as it enters an area where product has been previously applied. As the section leaves the previously applied area, the section control feature turns the section back on.

NOTE: A task controller or UT capable of automatic section control is required to allow the AIM Command FLEX™ system to control sections automatically. If auto section control is not enabled, automatic section control commands from the task controller will be ignored. Refer to the manufacturer operation guides and materials for information on utilizing this feature.



- If the UT is capable of automatic section control and the section control feature is available in the AIM Command FLEX™ Tools Menu, select the feature by placing a check mark in the corresponding box to enable the feature.
- If the UT is capable of automatic section control, but the section control feature is not available in the AIM Command FLEX™ Tools Menu, the feature must be enabled from a different UT menu. Review the UT operation manual for assistance with the section control or task controller options.
- If the UT is not capable of automatic section control, AIM Command FLEX™ will not automatically control sections regardless of the state of the section control feature on this screen. It is recommended to de-select or disable this feature when operating the AIM Command FLEX™ system without automatic section control.

EXTERNAL/RX CONTROL

Enable External/RX Control to allow the field computer to modify target application rate based on prescription map and/or the task controller on-screen rate entry fields.

Refer to the UT operation manual for assistance with loading and selecting prescription rate information for field applications.

PWM HIGH SIDE DRIVE

Enables the valve driver to modulate the high side of the PWM valve and provide a constant ground return. Typically selected when using a PWM Boost Box.

ENABLE TURN COMPENSATION

The turn compensation feature automatically adjusts individual nozzle duty cycles when turning. The lowest NCV duty cycle should match Minimum Nozzle PWM value for innermost operating NCV in a turn. The highest NCV duty cycle may not be 100% due to maximum output capabilities of the NCV with a given tip size and system efficiency.

TURN COMPENSATION CALIBRATION

If the AIM Command FLEX™ Product Controller II ECU mounting position is modified or adjusted, recalibrate turn compensation to ensure the feature correctly adjusts nozzle rates during applications and ensure that the Product Controller II ECU orientation is configured properly.

NOTE: The Product Controller II ECU orientation is calibrated during the initial system calibration wizard. To recalibrate the Product Controller II ECU gyro, restart the calibration wizard or perform the following procedure.

To recalibrate the turn compensation feature:

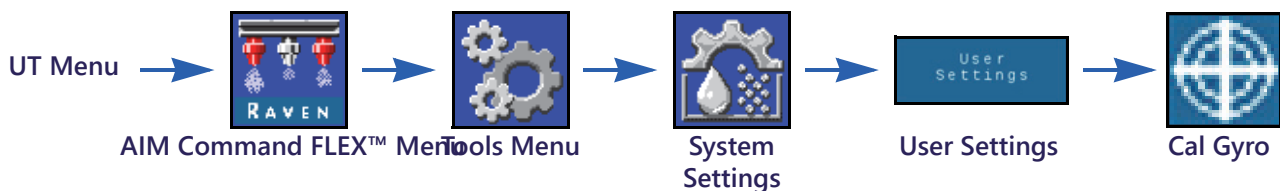

1. Move the equipment to a known level location.
2. Open the UT Menu and select the AIM Command FLEX™ Menu button.
3. Select the Tools Menu softkey along the right side of the display.
4. Select the System Settings tab along the top of the display.
5. Select the User Settings button and then select the Cal Gyro button. The system will recalibrate the Product Controller II ECU gyro and set the node orientation.

ENABLE WIRELESS CONTROL

Enable the wireless control feature to control pump, section valves, and nozzles along with performing remote diagnostic applications, using a Bluetooth low energy device when outside the cab.

OVERRIDE SECONDS

Use the override seconds value to set the time which the system should override automatic section commands and keep sections on. This feature may be used when starting application with the equipment at a complete stop, or to manually override all sections on for the set number of seconds.

NOTE: The default on override value is 15 seconds. The override seconds valve can only be changed outside of a job from this location. If the user desired to change this value while in a job, use the on screen override widget on the Viper 4.

The override will only activate sections set for automatic section control. Any sections configured for manual control, or set on or off manually, will not be affected by the AccuBoom Override feature.

SPEED CAL

Enter the Speed Cal value of the radar speed sensor (if equipped). Refer to the radar manufacturer's specification for recommended value and perform distance calibration to ensure accuracy.

NOTE: Speed Cal value may not be present on systems that display a Boom Sense/Speed Menu Icon on the UT.

NCV PERFORMANCE

The NCV performance indicator displays the current System Efficiency value and High, Average, and Low NCV duty cycles for any active NCVs. These values can be displayed on the lower home screen if the system is equipped with NCVs and there are less than three injection products connected to the system.

For information on the System Efficiency value, refer to the "System Settings Tab - Alarm" on page 25.

The High and Low values will display the highest, average, and lowest active NCV duty cycles on the system. These values will turn red if the values reach the maximum or minimum flow output capabilities of the NCVs for a given spray tip size. The High value will be 100% or less due to the flow limitations of the selected spray tip. The Low value may display the minimum nozzle PWM value, defaulted to 25%, or greater. When the operator is driving in a straight line, the High, Average, and Low values should be within 1-2% of each other unless a flow offset is active for any NCV. When Turn Compensation is utilized, the High and Low values will be significantly different, indicating the outside NCVs are operating at a higher duty cycle than the inside NCVs. These values should correlate to the NCV Duty Cycle values for the outermost active NCVs. The Average value is an average duty cycle of all active NCVs. The system should be operated so that, when at optimal spray height, the average value is maintained near 70% duty cycle. This will ensure optimal straight line and turn compensated spray coverage.

NOTE: This setting will not display in Bypass or On/Off Nozzle Control mode if three or more injection pumps are present or when the system is toggled in "Manual" application mode.

WIRELESS CONTROL MODE

SECTION

The remote wireless diagnostic device will command the associated NCVs on/off. The device will command the boom valve and it's associated NCVs on/off.

NOZZLE

The remote wireless diagnostic device will command the individual NCVs on/off if the remote device supports this mode. The mobile application does not support this mode. This may require additional supporting software.

GROUP END NOZZLES

Enabling this setting will link the three nozzles at the end of the boom to the NCV directly beside them. When one of the NCVs are turned on, all linked nozzles will turn on.

SYSTEM SETTINGS TAB - TANK FILL

To access the Tank Fill Settings menu for an injection product or the main product:

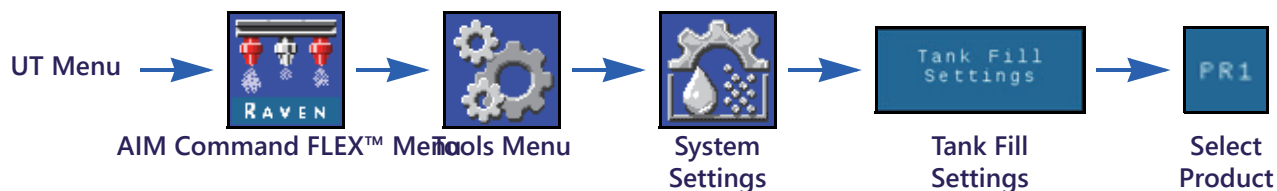

1. Open the UT Menu and select the AIM Command FLEX™ Menu button.
2. From the home screen, select the Tools Menu softkey along the right side of the display.
3. Select the System Settings tab along the top of the display.
4. Select the Tank Fill Settings button. The following information will be available:
 - Full Refill Button
 - Tank Level
 - Fill Meter Calibration Value and Units
 - Tank Capacity
 - Low Tank Limit
 - Max Tank Fill PWM

NOTE: The tank fill prompt is also accessible by selecting the tank indicator on the AIM Command FLEX™ lower home screen.

5. Select the Product tab that corresponds to the product being edited.

FULL REFILL BUTTON

Select to reset the current tank volume to the configured tank capacity. Use this button to quickly reset the tank volume when refilling tanks during field operation.

TANK CAPACITY

Enter the maximum tank capacity. Using the tank capacity and current tank level values, the tank indicator on the lower home screen will display the level of product remaining for the current application.

NOTE: Tank capacity value cannot be changed while in an application job.

TANK LEVEL

Enter the current tank level. This feature may be used to manually set the tank level at a level different from the capacity value, adjust the product volume if products are added through the top of the tank, or to correct the tank volume for a known volume of product added to the tank. Either enter the volume manually upon refilling or use the tank flow meter to automatically monitor the tank level.

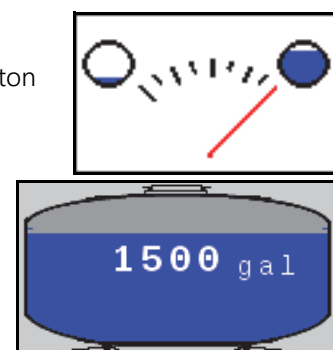

LOW TANK LIMIT

Enable the Low Tank feature and enter the desired volume threshold at which an alert will be displayed for low tank condition.

NOTE: To provide low tank alarms during field applications, ensure the Low Tank option is enabled on the Alarms Setup screen. Refer to the *System Settings Tab - Alarm* section on page 25 for additional assistance with enabling the low tank alarm.

FILL METER CALIBRATION VALUE AND UNITS (MAIN PRODUCT ONLY)

The fill meter calibration, or meter cal, value and units may be found on the tag attached to the flow meter installed in the tank fill system. Be sure to select the appropriate units for the flow meter calibration to ensure proper calibration of the tank fill system.

NOTE: Raven flow meters use a meter cal in pulses per 10 gallons [37.9 L].

Copy the information from the tag for future reference as tags may fade or be lost during operation.

MAX TANK FILL PWM

The maximum PWM the product pump will run at while filling the product tank while using the remote tank fill feature.

SYSTEM SETTINGS TAB - ALARM

To access the Alarm Settings Menu:

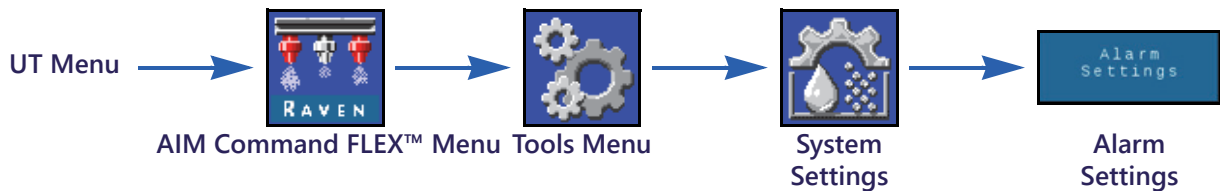

1. Open the UT Menu and select the AIM Command FLEX™ Menu button.
2. From the home screen, select the Tools Menu softkey along the right side of the display.
3. Select the System Settings tab along the top of the display.
4. Select the Alarm Settings button. The following information will display for the product number shown at the top of the screen:
 - Minimum Pressure
 - Off Target Pressure%
 - Sys Efficiency Limit
 - Stuck Poppet
 - Off Rate Limit
 - Low Tank Limit

MINIMUM PRESSURE

The minimum pressure feature will allow the operator to set the lowest tolerable pressure during field operations. If the application system reaches the minimum pressure, the UT will display an alert and the application system will maintain the flow rate to keep the monitored pressure consistent and to maintain the spray pattern.

OFF TARGET PRESSURE PERCENT

The off target pressure percent sets the allowable difference between the target and actual pressures. Enable the off pressure feature and enter a non-zero value to set the allowable difference between target and actual



pressures during field operations. If the difference between the actual and target pressure exceeds the set percentage for more than five seconds, the system will display an off pressure alarm.

SYSTEM EFFICIENCY LIMIT

The system efficiency limit feature allows the user to monitor system performance. The system will display an alarm in the actual efficiency exceeds the ideal efficiency by more than the set percentage. Typical efficiency may range from 90% - 105% during normal operation. System efficiency readings higher than 100% indicate that the system is delivering more flow than expected for a given NCV duty cycle. If the flow meter and pressure transducer are calibrated and operating correctly, and the tip size is selected properly, there may be a system leak after the flow meter or a malfunctioning NCV. System efficiency readings less than 100% indicate they system is delivering less flow than expected for a given NCV duty cycle. There may be a restriction or flow delivery issue to the NCVs.

LOW TANK LIMIT

Enable the Low Tank Limit feature and enter the desired volume threshold at which a low tank condition alert will display. Enter a value of zero or uncheck the Enable box to disable the alarm. Manually set the tank volume upon refilling or the tank fill flow meter will monitor the tank level.

STUCK POPPET

The stuck poppet alarm notifies the user if the NCV doesn't detect movement of the poppet. The NCVs must be assembly revision B or newer to support this feature. The revision level information is located on the NCV label.

SYSTEM SETTINGS TAB - PRESETS

To access the Preset Setup Menu:

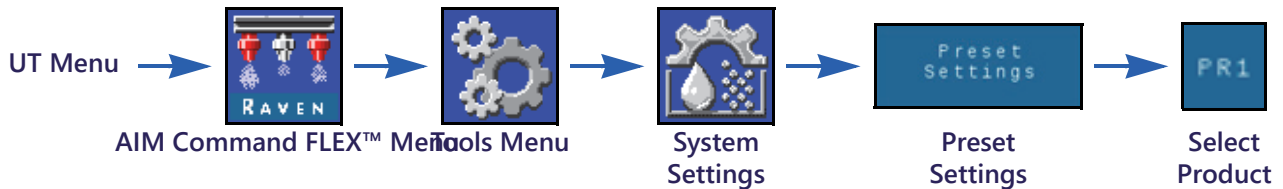

1. Open the UT Menu and select the AIM Command FLEX™ Menu button.
2. From the home screen, select the Tools Menu softkey along the right side of the display.
3. Select the System Settings tab along the top of the display.
4. Select the Preset Setup button. The following information may be available depending if the AIM Command FLEX™ or Sidekick product tab is selected:
 - Rate 1 and 2 (AIM Command FLEX™ and Injection)
 - Rate ± Bump (AIM Command FLEX™ and Injection)
 - Quick Key Setup
 - Pressure 1 and 2 (AIM Command FLEX™)
 - Pressure ± Bump (AIM Command FLEX™)
 - Use Gauges to Toggle Quick Key Selection
5. Select the desired product tab along the top of the display to change the products preset settings.

RATE 1 AND 2 PRESETS

Enter non-zero rate presets to allow the equipment operator to quickly switch between the set rates during field operations in the automatic product control mode. In some nozzle control modes, the pressure presets are disabled.

NOTE: Refer to the *Quick Access Softkeys* section on page 38 for additional assistance with using the rate preset and \pm bump buttons during field operations. In manual control mode, the rate preset and \pm bump buttons will be replaced with the pump PWM percent \pm bump buttons.

PRESSURE 1 AND 2 PRESETS

Enter non-zero pressure presets to allow the equipment operator to quickly switch between the set pressures during field operations in the automatic product control mode. Pressure presets are disabled in some nozzle control modes.

NOTE: Refer to the *Quick Access Softkeys* section on page 38 for additional assistance with using the pressure preset and \pm bump buttons during field operations. In manual control mode, the pressure preset and \pm bump buttons will be replaced with the nozzle PWM percent \pm bump buttons.

RATE AND PRESSURE \pm BUMP VALUES

Sets the increment by which either the target rate or target pressure will increase or decrease when using the bump softkeys during an active application. In some nozzle control modes, the pressure bump is disabled.

A separate bump value may be set for the rate and pressure control features. Refer to the *Use Gauges to Toggle Quick Key Selection* section on page 27 for assistance with toggling between rate and pressure bump displays on the home screen.

NOTE: Review the *Quick Key Setup Options* section on page 27 and enable the \pm option in the Quick Keys area to display the rate or pressure bump softkeys when viewing the home screen.

QUICK KEY SETUP OPTIONS

Select the following quick key options to set the softkey options available during operation:

Rate. Toggle the quick key option to “Rate” to display the Rate preset softkeys when viewing the home screen.

\pm (Bump). Enable the \pm bump softkeys when viewing the home screen.

Pressure. Toggle the quick key option to “Pressure” to display the Pressure preset softkeys when viewing the home screen.

USE GAUGES TO TOGGLE QUICK KEY SELECTION

Enable this option to use the rate or pressure gauges displayed on the home screen to toggle between the \pm bump and preset softkeys when viewing the home screen. This option allows the operator to quickly toggle between softkey functions without leaving the main operation display.

NOTE: The default selection for this feature is disabled.

SYSTEM SETTINGS TAB - PRODUCT CONTROL

To access the Product Control Settings Menu:

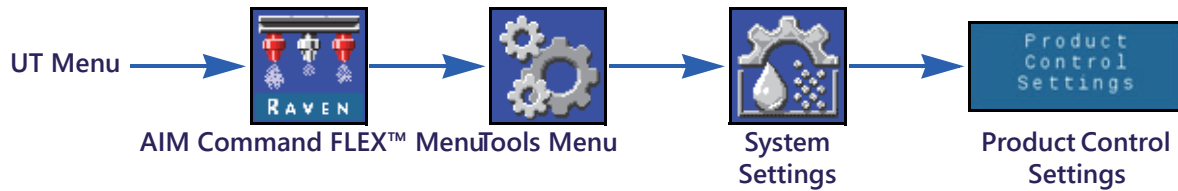

1. Open the UT Menu and select the AIM Command FLEX™ Menu button.
2. Select the Tools Menu softkey along the right side of the display.
3. Select the System Settings tab along the top of the display.
4. Select the Product Control Settings button. The following information will be available:
 - Valve Type
 - Max Pump PWM
 - Pump PWM Frequency
 - Flow Meter Cal
 - Deadband
 - Min Pump PWM
 - Standby Pump PWM
 - Minimum Nozzle PWM
 - Response Sensitivity
 - Product Type

VALVE TYPE

A PWM type control valve is preferred for proper operation of the AIM Command FLEX™ nozzle control system. Fast Valve and Standard Valve are available with a second pressure transducer required for proper operation.

NOTE: This setting can only be changed during system calibration and cannot be changed from PWM unless a Custom Boom profile is selected.

MIN PUMP PWM

Enter a minimum pump PWM to set the minimum desired output (zero point or shutoff point) for a pump controlled by a pulse width modulated (PWM) hydraulic control valve. The default value is zero.

MAX PUMP PWM

Enter a maximum pump PWM to set the maximum desired output for a pump controlled by a pulse width modulated (PWM) hydraulic control valve. This setting limits how far the PWM valve will open. The maximum operating pressure of the AIM Command FLEX™ nozzles is 80 PSI.

With the machine section and master switches in the on position, increase this value until the maximum desired pressure is reached in a liquid system.

STANDBY PUMP PWM PERCENT

Enter the desired pump PWM duty cycle percent when all sections are off. This is utilized when standby pressure control is not available (direct injection with a carrier check valve is installed). The default value is 42%.

PUMP PWM FREQUENCY

Used to set the coil frequency of the PWM valve (default is 60 Hz). Refer to the PWM control valve manufacturer specifications for recommended PWM frequency.

MINIMUM NOZZLE PWM PERCENT

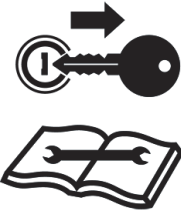
	<p style="text-align: center;">CAUTION</p> <p>Operating at an insufficient nozzle PWM percent may result in under application or skips in coverage.</p>
---	--

Enter a minimum PWM percent to set the minimum desired output (zero point or shutoff point) for the AIM Command FLEX™ nozzle control valves. With the machine master switch in the on position, decrease this value until the minimum desired spray pattern is reached in the liquid system. The default value is 25%.

NOTE: To help avoid under application or skips in coverage, review “Avoiding Skips with AIM Command FLEX™ Nozzle Control System” on page 69, and maintain the recommended application conditions.

FLOW METER CALIBRATION VALUE AND UNITS

Enter the calibration value for the flow meter used to monitor the AIM Command FLEX™ system product flow. The flow meter calibration value and units are on the tag attached to the system flow meter. Select the appropriate units for the flow meter calibration to ensure proper application system calibration information.

Raven flow meters use a meter cal in pulses per 10 gallons [37.9 L].

RESPONSE SENSITIVITY

The response sensitivity controls how sensitive the system is to changes in pressure, flow, and speed. Decrease if the system pressure and rate oscillate slightly. Increase sensitivity if control is unresponsive. Avoid setting response rate and sensitivity above 70.

DEADBAND

Sets the allowable tolerance between the target rate and the actual application rate. Enter a value between 1 and 9. A value of 1 equals a ±1% tolerance between the target and actual application rates where a value of 9 equals a ±9% tolerance. Default product control deadband is 1%.

PRODUCT TYPE

Select Water Based or Fertilizer. AIM Command FLEX™ will compensate for the different flow characteristics of each liquid.

NOTE: The meter cal may need to be adjusted when changing product types.

SYSTEM SETTINGS TAB - PRESSURE

NOTE: This tab will only show when a transducer is connected.



To access the Pressure Settings Menu:

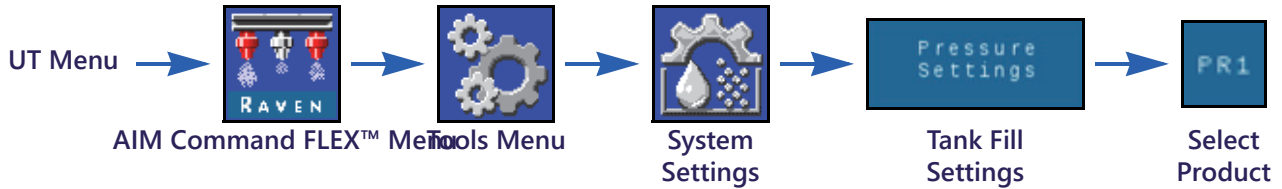

1. Open the UT Menu and select the AIM Command FLEX™ Menu button.
2. Select the Tools Menu softkey along the right side of the display.
3. Select the System Settings tab along the top of the display.
4. Select the Pressure Settings button. The following information will be available:

- Response Rate
- Minimum Pressure
- Maximum Pressure
- Boom Pressure Calibration
- Advanced Pressure Calibration

RESPONSE RATE

The response rate controls how fast the system adjusts pressure and rate output. Decrease response rate if system pressure and rate oscillate greatly. Increase if control is unresponsive. Avoid setting the response rate and sensitivity above 70.

MINIMUM PRESSURE

The minimum pressure feature requires a pressure transducer to monitor product pressure during application and will allow the operator to set the lowest tolerable pressure during field operations. If the application system reaches the minimum pressure, the UT will display an alert and the application system will maintain the flow rate to keep the monitored pressure consistent and to maintain the spray pattern. Default is 20 PSI.

NOTE: The minimum pressure feature may result in higher than desired application rates. If the minimum pressure feature will be used during field operations, be sure to enter a value that will not interfere with normal target rates during field application.

MAXIMUM PRESSURE

The maximum pressure feature requires a pressure transducer to monitor product pressure during application and will allow the operator to set the highest allowable pressure during field operations. Enter the maximum desired pressure for the system. Upon exceeding maximum pressure, an alert will display, and the flow control will be overridden and the rate controller will maintain maximum pressure. For the AIM Command FLEX™ nozzle control, the maximum operating pressure of AIM Command FLEX™ nozzles is 80 PSI (550 KPA).

NOTE: The maximum pressure feature may result in lower than desired application rates. If the maximum pressure feature will be used during field operations, be sure to enter a value that will not interfere with normal target rates during field application.

SPARGE PRESSURE CALIBRATION

This option will only appear if a transducer is detected. Sparge Pressure Calibration calibrates the sparge pressure transducer (if present) to a known value. The system will calibrate this automatically during the calibration wizard but the value can be adjusted at any time. Calibrate to a known pressure using a pressure gauge or turn the product pump off and open the section valves to relieve sparge pressure before resetting to zero.

Sparge Pressure Calibration is presented on the control valve selection on PWM and a second pressure transducer is detected on the sparge or system agitation line. This value can typically be controlled by an operator in the cab.

For Fast or Standard valve operation, this value changes to Pump Pressure and represents the pressure at the pump. The system will control the Pump Pressure value if the master switch or all boom switches are Off.

BOOM PRESSURE CALIBRATION

This option will only appear if a transducer is detected. A boom pressure transducer is required for AIM Command FLEX™ system operation. Calibrates the boom pressure transducer (if present) to a known value. The system will calibrate this automatically during the calibration wizard but the value can be adjusted at any time. Calibrate to a known pressure using a pressure gauge or turn the product pump off and open the section valves to relieve boom pressure before resetting to zero.

PRESSURE TRANSDUCER CALIBRATION

To calibrate the AIM Command FLEX™ system pressure transducers:

1. Open the UT Menu and select the AIM Command FLEX™ Menu button.
2. Select the Tools Menu softkey along the right side of the display.
3. Select the System Settings tab along the top of the display.
4. Select the Pressure Settings button.
5. Verify the Pressure Type and Transducer Type selections.
6. Zero the transducer at ambient air pressure. Refer to the Advanced Transducer documentation provided with the equipment, or contact the equipment manufacturer, for assistance with bleeding pressure from the application system.

NOTE: If the AIM Command FLEX™ system came installed on the equipment from the equipment manufacturer, or if a sparge pressure transducer is installed with the AIM Command FLEX™ control system, check the transducer specifications and refer to the Advanced Transducer Calibration to verify transducer settings before operating the AIM Command FLEX™ nozzle control system during field applications.

ADVANCED TRANSDUCER CALIBRATION

Navigate to the second page of the Pressure Settings menu to access the following settings:

Pressure Type. Select the pressure type drop down field and select the boom or sparge transducer to be calibrated for AIM Command FLEX™ operation.

Transducer Type. Select the transducer type drop down field and select the range for the transducer used with the AIM Command FLEX™ system. The following options are available for calibrating the AIM Command FLEX™ nozzle control system:

- Raven (0-250) - Pressure transducer supplied with after-market AIM Command FLEX™ systems. This option is the default transducer type setting.
- Other (0-150) - Before selecting this option, check the specifications of the pressure transducer used to monitor application with the AIM Command FLEX™ nozzle control system.
- Custom (set custom transducer limits) - If neither of the above options match the transducer specifications, select the custom option to set the limits for the pressure transducer used with the AIM Command FLEX™ nozzle control system.

Pressure Calibration. Enter the gauge pressure or recalibrate the transducer for ambient air pressure.

CONTROLLER DIAGNOSTICS INFORMATION TAB

The controller diagnostics tab provides status information for the AIM Command FLEX™ Product Controller II ECU and may be helpful when troubleshooting the system. To access AIM Command FLEX™ system Diagnostic Information:

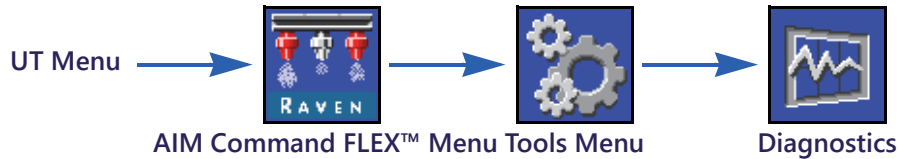

1. Open the UT Menu and select the AIM Command FLEX™ Menu button.
2. From the home screen, select the Tools Menu softkey along the right side of the display.
3. Select the Diagnostics Info tab along the top of the display. The following controller information will be displayed:

Page 1	Page 2	Page 3	Page 4
<ul style="list-style-type: none"> • HC Voltage • Logic Voltage • System Efficiency • Pump Duty Cycle • Tank Fill Sense • Flow Pulses • ECU Yaw Rate • Pressure Signal • Orifice Constant • Pressure Offsets • Orientation • ISO CAN Errors 	<ul style="list-style-type: none"> • NCV Can Errors • NCV System State • Total Nozzles • Serial Number • Voltage and Version • Resend NCV Cal 	<ul style="list-style-type: none"> • NCV Can Error Code • Switch Status Table • Left/Right Outputs • Calibrate NCVs • NCV Switched Input States • Switched Output Buttons 	<ul style="list-style-type: none"> • CAN Communication • NCV Temperature • Power Load • Boom Pressure Relief • Validate NCV Indexing

Boom Pressure Relief. This diagnostic test will actuate all the NCVs to relieve the boom pressure. This is intended to be done before doing any work on the boom that requires the pressure to be bled off.

CAN Communication. This diagnostic test monitors the CAN bus while powering NCVs to determine if there are any CAN Communication issues.

DTC List. The diagnostic trouble code (DTC) list provides a list of recent errors for the equipment operator. Access the DTC list to review previous error conditions, as well as a tally of each condition, during operation of the AIM Command FLEX™ nozzle control system. Refer to Chapter 8, *Troubleshooting*, for additional assistance with diagnostic trouble codes and using the DTC list.

Flow Pulses. 4. Displays flow pulses received from the system flow meter. This value should be above zero when product is flowing through the flow meter.

HC Voltage. The voltage for the high current bus circuit. High current power is provided system components to actuate control features such as opening valves or nozzles. Normal values range from 10.5 - 16 VDC.

ISO CAN Errors. This value counts the number of CAN errors the system has encountered on the primary ISO CAN bus. The value should remain constant under normal operation. If the value rapidly increases, inspect the ISObus for damage components or connections.

Left/Right Outputs. The Left Output and Right Output buttons can be used to manual turn on the switched outputs from the main ECU to the NCVs on or off.

Logic Voltage. Internal Product Controller II ECU voltage used for processing application data and rate control commands. The logic voltage value should display 4.8V or higher for normal operation of the AIM Command FLEX™ Product Controller II ECU and the AIM Command FLEX™ nozzle control system.

NCV #. The NCV number will populate correctly from left to right along the boom when all NCVs are calibrated.

NCV CAN Errors. This value counts the number of CAN errors the system has encountered on the NCV CAN bus. During normal operation.

NCV Switched Input State. Displays the state of the Switched input of the NCV. A value of one indicates a voltage is detected.

NCV System State. Displays the current state of the NCVs. This might change if the NCVs are calibrating or operating. Information such as the NCV number, NCV serial number, voltage, and NCV version are all visible on this page.

NCV Temperature. This diagnostic test requests the internal temperature data from each NCV and determines if the NCV temperatures are within acceptable ranges.

Orientation. Displays the orientation number of the node pointing down. This number is used to calibrate the system gyro for turn compensation.

Power Load. This diagnostic tests turns on all the NCVs at 100% and checks the voltage at each NCV and determines if the NCV Voltages are within acceptable thresholds.

Pressure Signal. Displays pressure signal as a voltage from the boom pressure transducer. The value should be not be zero when the boom is pressurized.

Product Controller II ECU Yaw Rate. Represents the current turn rate of the vehicle and AIM Command FLEX™ Product Controller II ECU. This value is used for turn compensation and will change to a positive value when turning right and a negative value when turning left. This value should be at, or near, zero when the vehicle is stationary.

Pump Duty Cycle. Displays the current carrier pump output percentage.

Resend NCV Cal. Select the Resend NCV Cal option to resend the calibration data to each of the NCVs detected on the nozzle control bus.

Serial Number. This will populate with the individual NCV serial numbers detected before or after calibration.

Switched Output Buttons. The Switched Output Buttons control the switched output from the PCII ECU that are wired to the switched inputs of the first NCV on each side of the boom.

Switch Status Table. The Switch Status Table displays the switched input status of each NCV. A value of one indicates voltage is detected on the input of the NCV. This table can be used to determine locations where NCV indexing could fail.

System Efficiency. The system efficiency allows the user to monitor system performance. Typical efficiency may range from 90% - 105% during normal operation.

Tank Fill Sense. Tank Fill Sense values change from 0 - 100% when the system senses a remote tank fill is in progress.

Total Nozzles. The number of NCVs detected by the system. After the system is fully calibrated, the total number of nozzles should match the total NCVs on the system.

Validate NCV Indexing. This diagnostic test checks all of the switched inputs that are used for indexing for each NCV to ensure they are functioning properly.

Version. This will display the software version of the NCV after it is calibrated.

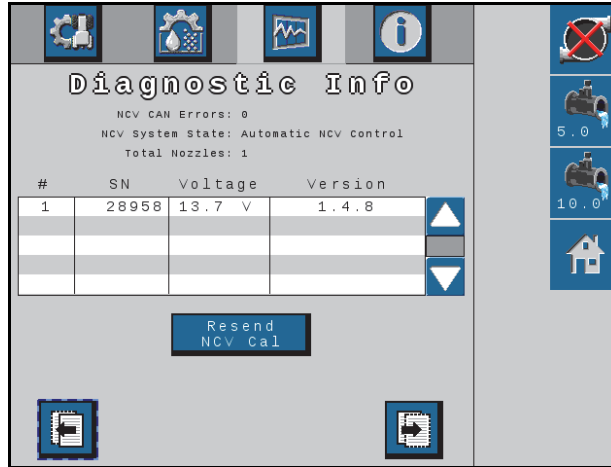

Voltage. This will populate with the individual NCV voltage if it is calibrated.

SYSTEM INFORMATION TAB

To access the System Information Menu:

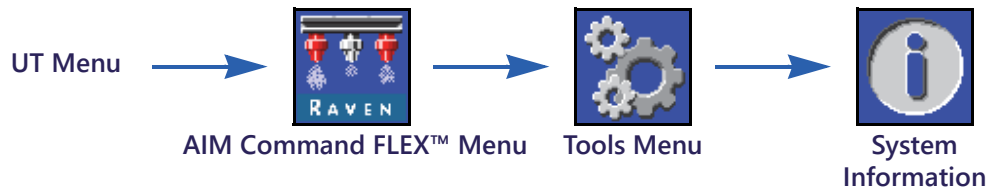

1. Open the UT Menu and select the AIM Command FLEX™ Menu button.
2. From the home screen, select the Tools Menu softkey along the right side of the display.
3. Select the System Information tab along the top of the display. The following information will be available:
 - Product Controller II ECU Part Number
 - Hardware Serial Number
 - Software Version
 - Total Hours
 - Wireless Status
 - Wireless ID
 - PCB Part Number
 - Task Controller Status
 - Software Part Number
 - Bootloader Version
 - Version Hours
 - Total Runtime Hours
 - CAN Address
 - Product Controller II ECU Revision
 - PCB Revision

NOTE: This information is for display purposes only and may be useful when contacting technical support.

WIRELESS

Shows the status of the connected wireless device. Unknown will display if no device has been connected. Connected will display if the device is connected but not in control. Active will display if the device is connected and in control.

WIRELESS ID

Displays the internal wireless module ID. This value will be displayed on the wireless diagnostics application when trying to connect to AIM Command FLEX™ Product Controller II ECU.

RESET DEFAULTS

Select the reset defaults button to restore the default system settings. All user settings will be reset and the initial calibration wizard must be completed before operating the AIM Command FLEX™ nozzle control system.

NOTE: Prior to performing a software update, record all settings in the "Calibration Reference Sheet" on page v. After the update is complete, reset the system defaults and recalibrate the system.

FEATURE UNLOCKS

Unlocks allow the user to activate features through the use of an activation key. Unlocked features are visible on the feature unlock screen. Contact a Raven dealer for information on acquiring feature unlocks.

SERVICE MENU

Provides advanced features and options to assist with systems diagnostics or tuning the AIM Command FLEX™ nozzle control system. The service menu should only be used by a trained Case IH service technician.

Contact a local Case IH dealer for assistance with the AIM Command FLEX™ nozzle control system if necessary.

OPERATION CHECKLIST

To begin applying product using the AIM Command FLEX™ nozzle control system:

1. Verify that nozzle control is enabled.
2. Verify the proper control mode (Standard, Bypass, On/Off, High Flow, High Flow VP, or VP) is enabled.
3. Set to the desired target rate.
4. Verify the nozzle tip size selection for the AIM Command FLEX™ nozzle control system.
5. Verify the product type (Water Based or Fertilizer). Refer to the *System Settings Tab - Product Control* section on page 28.
6. Set the desired target pressure. Refer to the *Target Pressure* section for additional information.

NOTE: Target pressure is not available in VP, High Flow VP, ON/OFF, and Bypass modes.

7. If the machine is equipped with a master tank valve, verify the tank valve is open to direct flow to the carrier pump.
8. If the machine is equipped with a toggle switch to engage the pump, it may be necessary to engage the switch before using the Engage Pump softkey on the AIM Command FLEX™ screen.
9. Select the product pump softkey to toggle the product pump on. Refer to the *Main Product Pump Switch* section for additional information.
10. For systems with Sidekick Pro ICD injection, select the product selection button for the desired injection pump in the lower home screen. Select the product on/off button in the upper home screen to turn the injection product on with the master switch.
11. Toggle the equipment master switch to the on position.

AIM COMMAND FLEX™ HOME SCREEN DEFINITIONS

To access the AIM Command FLEX™ home screen, select the AIM Command FLEX™ Menu button on the UT Menu.



FIGURE 1. Home Screen

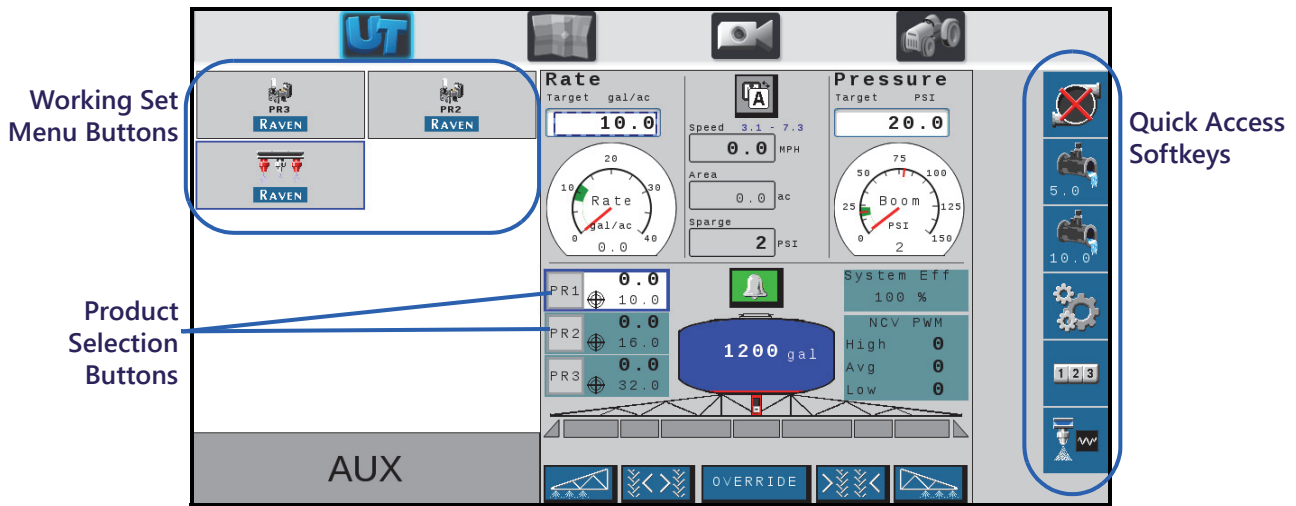

Depending upon the mode and system options, the following display areas, information prompts, and features may be accessible via the AIM Command FLEX™ home screen:

• Softkeys Area	• Rate and Pressure Target Values	• Rate and Pressure Gauges	• Master Switch Status Display
• Application Mode Selector	• Alarm Status Display	• Volume Applied Tally	• Area Covered Tally
• Product Select Buttons	• Tank and Section Status Display	• On-Screen Section Controls	• Home Screen Toggle

QUICK ACCESS SOFTKEYS

The quick access softkeys allows the operator to quickly access frequently used functions, calibration settings, and status displays during operation. Review the following sections for additional information on softkey functions.

MAIN PRODUCT PUMP SWITCH

The status of the product pump is always displayed in the softkeys area. Select the pump status indicator to toggle the main product pump on or off during field applications.

NOTE: Both the master switch and the product pump softkey must be toggled on to apply product. If the machine has an additional switch to open a master tank valve and/or turn on the main product pump, ensure the machine’s switch is turned on before the on-screen softkey is used and the master switch is toggled on to prevent pressure spikes in the system when starting application.

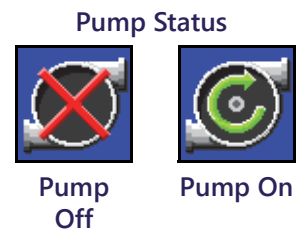

± BUMP

While applying in the automatic control mode, the operator may elect to display the ± rate or pressure bump softkey in the softkeys area. Select these softkeys to manually increase or decrease the target rate or pressure settings by the ± value set on the presets settings prompt.

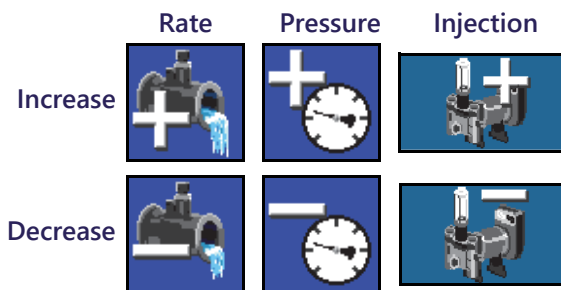

Refer to the *System Settings Tab - Presets* section on page 26 for additional assistance with the rate and pressure ± values and using the rate or pressure gauges on the home screen to toggle between the rate and pressure ± softkeys.

PRESET

While applying in the automatic control mode, the operator may select to display the rate or pressure preset softkey in the softkeys area. Select these softkey to manually toggle between two preset rates or pressures set using the presets settings prompt.

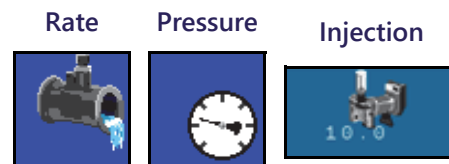

Refer to the *System Settings Tab - Presets* section on page 26 for additional assistance with the rate and pressure preset values and using the rate or pressure gauges on the home screen to toggle between the rate and preset softkeys.

MAIN PUMP MANUAL CONTROL

In the manual control mode, the rate ± bump and preset softkeys are replaced with manual pump ± buttons. Select these softkey to manually increase or decrease the main product pump or injection pump output during a field application. The Main Product Pump Manual Control softkeys are replaced by the Injection Pump Manual Control Softkeys when the injection pump product is selected.

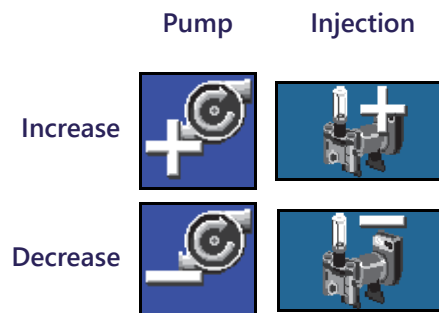

The system will continue to monitor and display the actual application rate on the home screen.

MANUAL NOZZLE CONTROL BUTTONS

In manual control mode, the pressure ± bump and preset softkeys are replaced with manual nozzle ± softkeys. Select these softkeys to manually increase or decrease the nozzle control valve duty cycle during a field application.

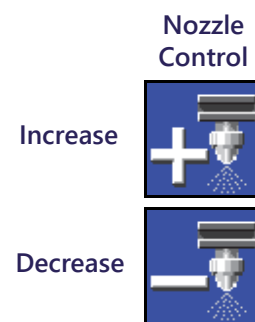

The AIM Command FLEX™ system will continue to monitor and display the actual system pressure on the home screen.

TOOLS MENU

Select the Tools Menu softkey to access the calibration prompts. See Chapter 4, *AIM Command FLEX™ Nozzle Control and Sidekick Pro ICD Setup*, for additional assistance with system calibration, features, and settings.



TALLY REGISTERS

Select Tally Registers to view the volume and area tallies since the register was last reset. See Chapter 6, *Tally Registers*, for additional assistance with the tally registers features.



Tally Registers

NOZZLE DIAGNOSTICS

Select Nozzle Diagnostics to access nozzle diagnostic information and settings such as nozzle control valve status or selecting the tip size for AIM Command FLEX™ operation. Refer to Chapter 7, *AIM Command FLEX™ Nozzle Control Valve Diagnostics*, for additional assistance with the AIM Command FLEX™ Nozzle diagnostics prompts.

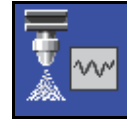

Nozzle Diagnostic

NOTE: This button also indicates the nozzle control mode. The images below show the nozzle control mode.

FIGURE 2. Mode Softkeys



AIM COMMAND FLEX™ UPPER HOME SCREEN

The upper portion of the AIM Command FLEX™ home screen displays the application information for the selected product as well as the units in which the information is displayed. Review the following sections for assistance with the rates information and display on the AIM Command FLEX™ home screen.

FIGURE 3. AIM Command FLEX™ Upper Home Screen

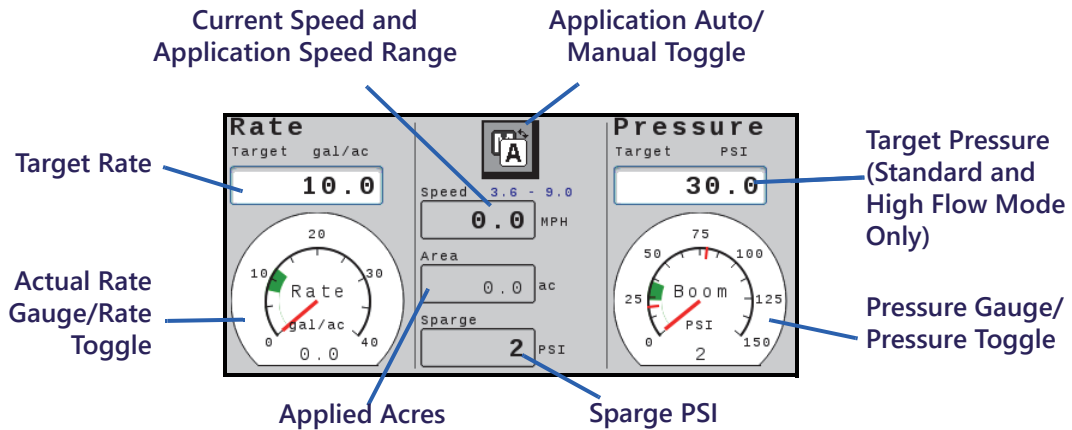
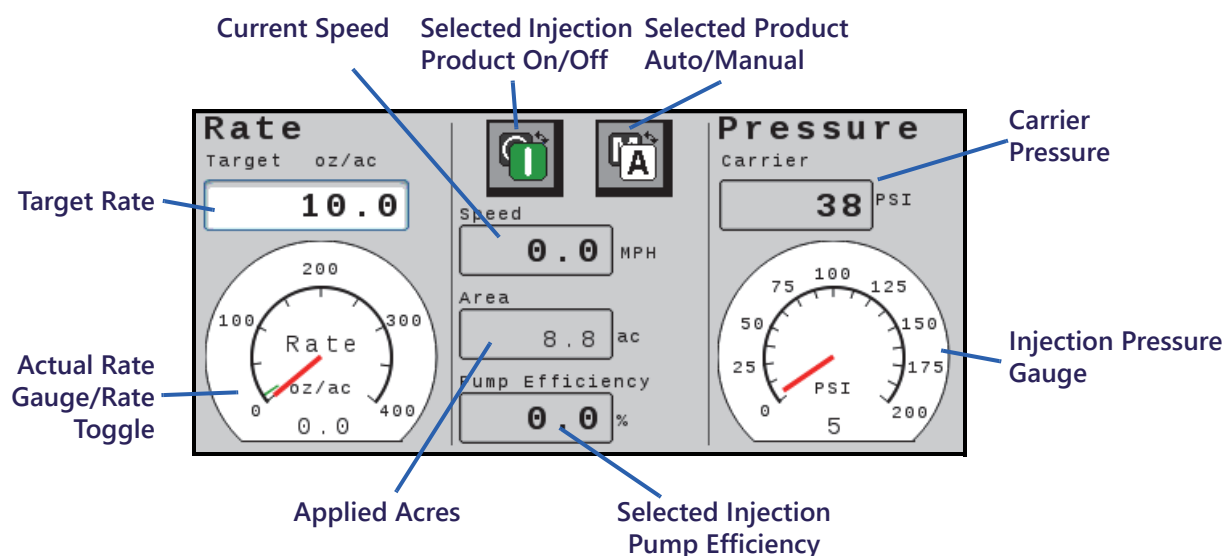

FIGURE 4. AIM Command FLEX™ with Injection Upper Home Screen



AREA APPLIED

The field area applied tally is displayed in the application area for quick reference of the area covered during the current operation.

TARGET RATE

Select the target value to enter the desired target rate for product application (e.g. 15 gallons per acre [140 liters per hectare]).

RATE GAUGE

The rate gauge provides a visual representation of the actual application rate and displays the allowable rate deadband during field applications.

NOTE: Refer to the *System Settings Tab - Alarm* section on page 25 for assistance with setting the rate gauge deadband or the *Flow Meter Maintenance* section on page 89 for additional assistance with calibrating the flow meter.

If the *Use Gauges to Toggle Quick Key Selection* option is enabled, touch the rate gauge to toggle between the rate preset and rate \pm bump buttons in the softkeys area. Refer to the *System Settings Tab - Presets* section for additional assistance with the rate and pressure presets options.

APPLICATION MODE

The application mode indicator displays the selected mode for product control. Select the "Auto/Manual" button to toggle the application mode between automatic (Auto) and manual (Manual). The active mode will display.

FIGURE 5. Manual/Auto Toggle



Manual. Allows the operator to manually adjust the pump and nozzle PWM output to control the system rate and pressure. Select the pump increase or decrease buttons while viewing AIM Command FLEX™ home screen to manually increase or decrease the pressure.

Automatic. Allows the product control system to automatically acquire and maintain the set target application rate and pressure. Use the \pm bump or preset buttons to adjust the target rate or pressure during field applications.

Selected Injection Product On/Off. This button  toggles the selected injection product on or off.

NOTE: The product must be on before the injection pump will operate with the AIM Command FLEX™ system.

CURRENT VEHICLE SPEED AND APPLICATION SPEED RANGE DISPLAY

AIM Command FLEX™ displays the current vehicle speed on the AIM Command FLEX™ home screen. Above the vehicle speed display, AIM Command FLEX™ provides the operator with the application speed range. This range is provided as the optimal range to maintain the target rate and pressure settings. If the application speed exceeds this range, alarm conditions may occur and the AIM Command FLEX™ nozzle control system may be unable to maintain the desired application rate or pressure. Refer to “Avoiding Skips with AIM Command FLEX™ Nozzle Control System” section on page 69 for additional information about maintaining coverage during application and application speed ranges with the AIM Command FLEX™ nozzle control system.

NOTE: The ranges for speed and flow rate provided in the “Avoiding Skips with AIM Command FLEX™ Nozzle Control System” section on page 69 are for reference purposes only. Actual speed ranges will depend on the main product pump performance, system plumbing configurations, and specific spray tip flow characteristics. Displayed speed range minimum is 10% greater than the actual minimum. The displayed speed range maximum is 10% less than actual maximum speed. For best system performance operate the system within the displayed speed range.

TARGET PRESSURE

Select the target value to enter the desired target pressure for product application (e.g. 45 PSI [310 kPa]). For systems with injection, the pressure reading displays the current carrier pressure readout when an injection product is selected.

NOTE: Not available for VP, On/Off, High Flow VP, and Bypass modes.

PRESSURE GAUGE

When the AIM Command FLEX™ product is selected, the pressure gauge provides a visual representation of the actual boom or sparge pressure and displays the allowable pressure deadband during field applications.

NOTE: Refer to the *Boom Pressure Calibration* section on page 31 for additional assistance with calibrating the pressure transducer or configuring the pressure deadband.

If the *Use Gauges to Toggle Quick Key Selection* option is enabled, touch the pressure gauge to toggle between the pressure preset and pressure \pm bump buttons in the softkeys area. Refer to the *System Settings Tab - Presets* section on page 26 for additional assistance with the rate and pressure presets options.

When an injection product is selected, the pressure gauge displays the pressure at the injection pump.

INJECTION PUMP EFFICIENCY

The injection pump efficiency value indicates the performance of the selected injection pump. Values may vary based on pump performance and product being applied. The acceptable limit is set in the injection alarm settings tab.

AIM COMMAND FLEX™ LOWER HOME SCREEN

The lower portion of the AIM Command FLEX™ home screen provides on-screen indicators for alarm status, switch status, remaining tank volume, the volume of product applied for the selected product during the field operation. Refer to the following sections for additional information regarding the information provided in this area of the AIM Command FLEX™ home display.

FIGURE 6. HD with Injection Lower Home Screen

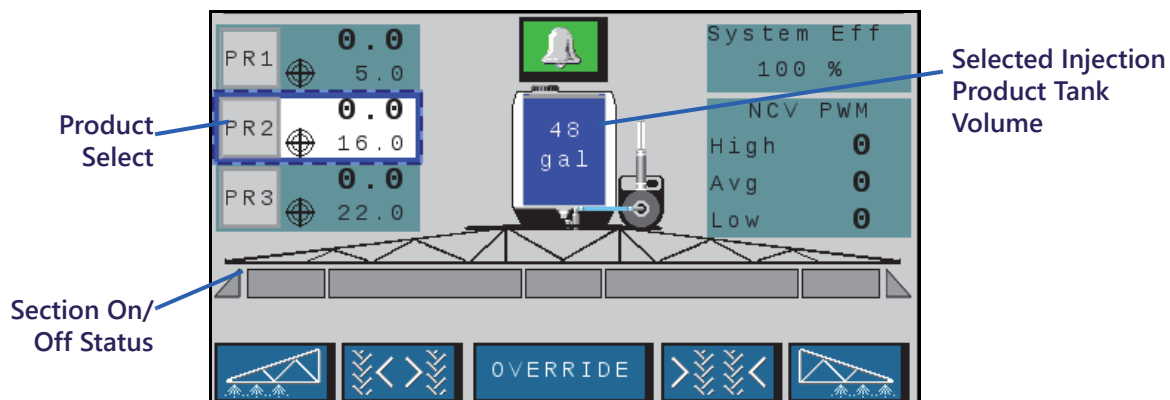
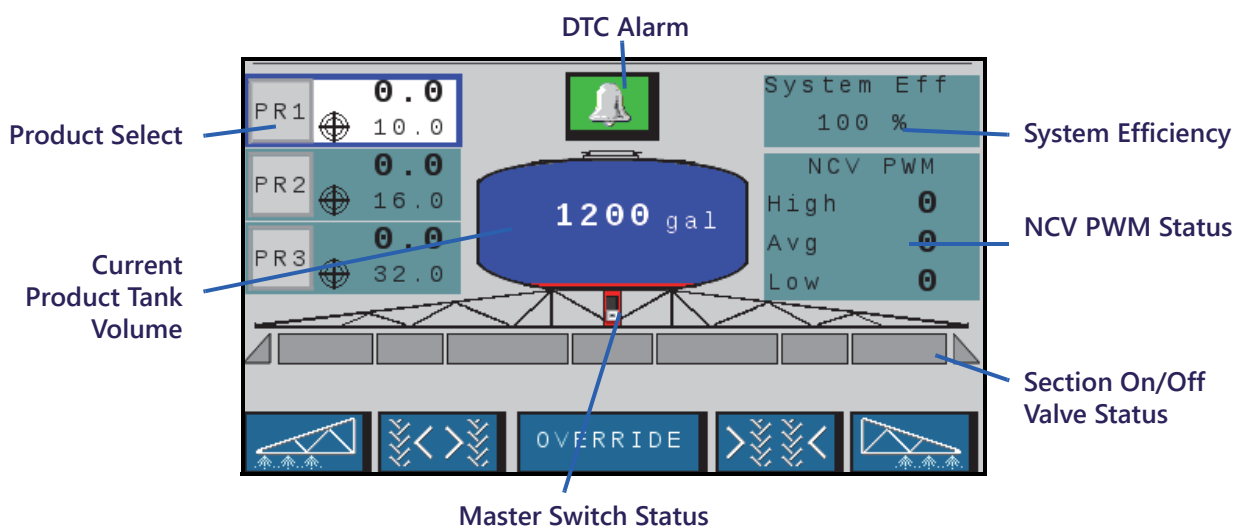

FIGURE 7. Virtual Section Lower Home Screen





PRODUCT SELECTS

Product Selects shows the target application rate if the product is calibrated and the product is toggled on, and the actual rate for each product being applied when the master switch is on. Select the product to make changes to a product. PR1 is reserved for the AIM Command FLEX™ system. PR2 - PR6 are used for additional injection products.



DTC ALARMS STATUS INDICATOR

The alarm indicator provides a visual status of the AIM Command FLEX™ Nozzle Control System and Sidekick Pro ICD injection pump alarms during field applications. The alarm status indicator provides the following display states:

	OK. The system status is normal and no alarm conditions are currently present.
	Caution. A minor alarm condition has been detected. The control system is operating normally, however, the system has detected that a condition exists which could impact the current application.
	Critical. A critical system condition has been encountered. The control system is not responding as expected and the operator should cease application and troubleshoot the issue before resuming operations. The system will not apply in this state

Touch the Alarms Status indicator to quickly access the diagnostic trouble code (DTC) List and review any current or previous alarm condition information. Refer to Chapter 8, *Troubleshooting*, for additional assistance with diagnostic trouble codes and using the DTC list.

TANK VOLUME INDICATOR

The system provides a calculated volume of product remaining in the tank as a tank indicator in the application information area. Select this indicator to access the Tank Fill Config prompt.



NOTE: A tank capacity value must be entered to allow the tank volume indicator to display the tank level.

VOLUME APPLIED

Volume applied is for quick reference of the volume of product dispensed during a field operation. The field volume tally is displayed if there are less than three injection products and the NCV Performance Indicator is off.

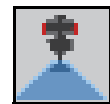

NOTE: Tally registers from the softkeys area and refer to Chapter 6, *Tally Registers*, for additional assistance with using the field and total volume registers.

SECTION STATUS DISPLAY

The AIM Command FLEX™ system provides the status of each configured section on the home display. For standard AIM Command FLEX™ section control, or AIM Command FLEX™ Virtual Section mode, the boom valve section will be a rectangle above triangles representing the nozzle control sections. The triangles will change color when the section is turned on. For AIM Command FLEX™ HD mode, the rectangles represent the boom valve and nozzle control sections and the rectangles will change color when the boom valve section is on.

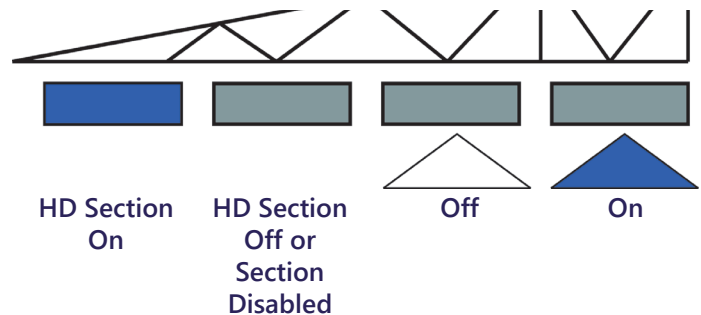

NOTE: Refer to Chapter 3, *System Calibration*, and restart the calibration wizard to configure implement sections.

- Manually disabled sections will be displayed without a section status indicator below the section.

Sections enabled for product application will display a status below the section.

- Sections automatically controlled off according to task controller commands will display with an empty status indicator. The task controller will automatically enable the section when the section returns to an unapplied area in the field application.

When the application system is enabled, the indicator for each section actively applying will be filled in. Task controller may automatically shut off the section based upon the application coverage map.

WHEEL TRACK PROFILES



These icons will only appear if a nozzle flow offset is entered and a valid machine profile is selected.

Left. The eight nozzles on the far left of the boom will increase flow by the user entered nozzle flow offset percentage.

Extended. The eight nozzles behind the tires when the wheels are extended will increase flow by the user entered nozzle flow offset percentage.

Retracted. The eight nozzles behind the tire when the wheels are retracted will increase flow by the user entered nozzle flow offset percentage.

Right. •The eight nozzles on the far right of the boom will increase flow by the user entered nozzle flow offset percentage.

ON-SCREEN OVERRIDE

Use the override button at the bottom of the AIM Command FLEX™ home screen to override all sections for the configured override time. After the override time expires, the task controller will resume automatic operations based upon previous section coverage.

Refer to the *Tools Menu Settings Definitions* section on page 18 for additional assistance with the override seconds setting if necessary.

SYSTEM EFFICIENCY

This information is only available when less than three injection pumps are on the system.

Normal operating values should be between 90 - 105% for various sprayer models. System efficiency may change slightly in a turn when the turn is tighter than the spray boom is capable of without some nozzles operating at the set minimum nozzle PWM (minimum NCV duty cycle). System efficiency generally increases when NCV duty cycle drops below the expected theoretical value, indicating more than expected flow is being provided for an expected NCV duty cycle at a given target rate, pressure, and tip size. Examples include when there is a leak, tip size is programmed too large, flow meter calibration value is too low, pressure calibration value is too high, a poppet is stuck open or excessively worn, a fencerow output is turned on, or a spray tip is excessively worn or missing. System efficiency generally decreases when NCV duty cycle is higher than the expected theoretical value indicating less than expected flow is being provided for an expected NCV duty cycle. Examples include a boom valve not opening, a tip size programmed too small, flow meter calibration too high, pressure calibration value is too low, a poppet is stuck closed or not opening completely, or a spray tip is obstructed.

System Eff
100 %

NCV PWM STATUS

This information is only available when less than three injection pumps are on the system. Values for High, Avg, and Low should increase or decrease as expected for changes in speed, target rate, in a turn, and when a flow offset is enabled. Values go to zero when master switch or all boom switches are off. Values should be the same as what the outermost operating NCV reports for Duty Cycle%. Values turn red when NCVs are at their maximum and minimum outputs. Maximum output may not be 100% due to maximum output capabilities of the NCVs for a given tip size and system efficiency. Minimum values should be the same as the minimum nozzle PWM value or the innermost operating NCV in a turn.

NCV PWM	
High	0
Avg	0
Low	0

USING TALLY REGISTERS

To access the AIM Command FLEX™ tally registers prompt:



1. Open the UT Menu and select the AIM Command FLEX™ Menu button.
2. From the home screen, select the Tally Registers softkey along the right side of the display.

RESETTING A REGISTER

To reset a register:

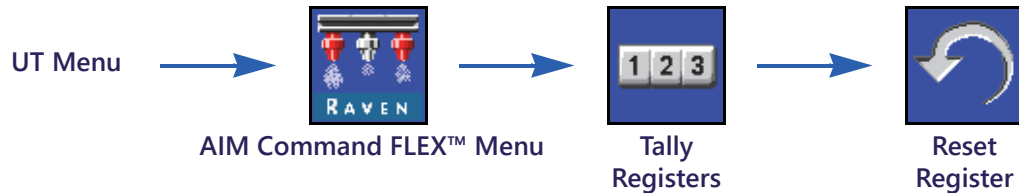

1. Open the UT Menu and select the AIM Command FLEX™ Menu button.
2. From the home screen, select the Tally Registers softkey along the right side of the display.
3. On the Totals Data tab, select the Reset button for the register to be reset.
4. Accept the confirmation prompt to reset the select register.
5. Repeat the above process to reset other tally registers as desired.

TALLY REGISTER DEFINITIONS

The AIM Command FLEX™ system provides the following registers:

- Task
- Distance
- Flow Rate
- Lifetime
- Device
- Area

In addition to the area and volume tallies, the tally registers screen also displays the distance traveled and the current volume per minute and area per hour.

TASK TALLIES

The task area and volume registers allow the operator to keep a running tally of product application in a specific field or over a short duration of application such as a day or week.

LIFETIME TALLIES

The lifetime area and volume registers are intended to keep a running tally of a longer term of application data (i.e. product application over a week, month, or season).

DEVICE STATS

The device area and volume statistics register keeps a running tally of the operating life of the AIM Command FLEX™ system. This tally cannot be reset by the machine operator.

DISTANCE

The distance register functions as a AIM Command FLEX™ system odometer and provides a distance traveled since the last time the distance register was cleared. The distance register display may also be helpful when fine tuning the AIM Command FLEX™ system or to assist with troubleshooting procedures.

FLOW RATE DISPLAY

During product application, the current volume of product applied per minute is displayed on the Totals Data tab. This value may be helpful when fine tuning the AIM Command FLEX™ system or to assist with troubleshooting procedures.

AREA/HOUR DISPLAY

The current area covered per hour is available on the Totals Data tab. This value may be helpful to check the AIM Command FLEX™ system calibration or to assist with troubleshooting procedures.

CHAPTER

7

AIM COMMAND FLEX™ NOZZLE CONTROL VALVE DIAGNOSTICS

NOZZLE CONTROL VALVE DIAGNOSTIC DEFINITIONS

SECTION DIAGNOSTICS PROMPT

To access AIM Command FLEX™ nozzle control valve diagnostics information by configured section:



1. Open the UT Menu and select the AIM Command FLEX™ Menu button.
2. From the home screen, select the Nozzle Diagnostics softkey along the right side of the display. The following settings and information may be displayed for each configured section:
 - Section
 - Nozzle Spacing
 - Nozzle Flow Offset%
 - Section Nozzle Status

FIGURE 1. Advanced Nozzle Diagnostics

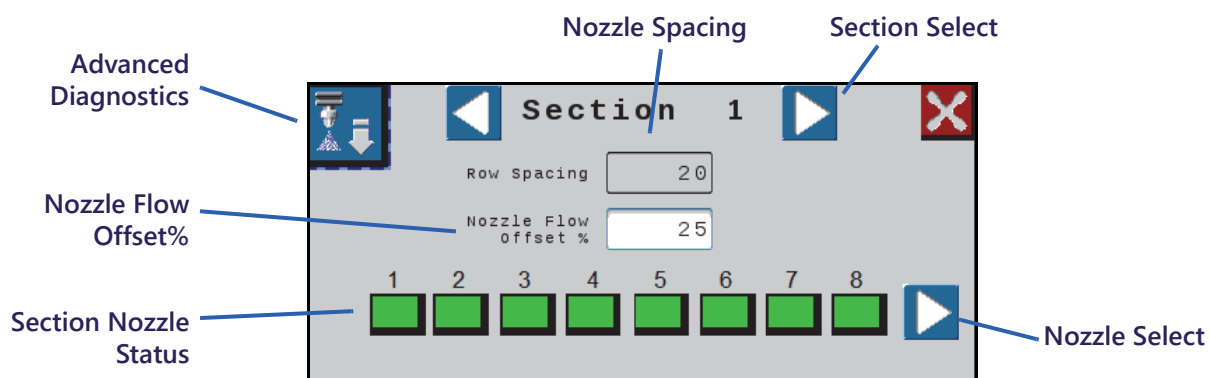

CURRENT SECTION DISPLAY





The current section for which diagnostic information is being displayed is shown at the top of the nozzle diagnostics prompt. Select the left or right section select arrow buttons to cycle through sections configured for use with the AIM Command FLEX™ nozzle control system.

NOZZLE SPACING

The nozzle spacing value set during the calibration wizard is displayed on the diagnostics prompt. Verify this value matches the tip spacing on the equipment to ensure accurate application of products during field operations.

SECTION NOZZLE STATUS

The status of each nozzle configured for control on the section is displayed at the bottom of the section diagnostics prompt. The following nozzle statuses may be displayed while viewing the section diagnostics prompt:

	Normal. The nozzle is functioning normally and no alarm conditions are currently present.
	Caution. A minor nozzle alert condition has been detected. The control system and nozzle PWM is operating normally, however, the system has detected that a condition exists which could impact the current application.
	Critical. A critical nozzle condition has caused the nozzle to shut down. The nozzle is not responding as expected and the operator should cease application and troubleshoot the issue before resuming operations.
	Not Calibrated. The nozzle section is not calibrated.

NOTE: Refer to Chapter 8, *Troubleshooting*, for additional assistance with diagnostic trouble codes and using the DTC list.

NOZZLE SELECT

Press the nozzle select arrow to cycle through each individual nozzle status and diagnostic information in the advanced diagnostics screen.

NOZZLE FLOW OFFSET %

The Flow Offset feature allows a limited number of nozzles to provide additional flow (Ex. nozzles in line with the sprayer wheel tracks). The Nozzle Flow offset percentage value sets how much the wheel track nozzle will deviate from nominal flow. See the *Individual Nozzle Diagnostics* section on page 50 for additional information.

NOTE: NCV offset percentage entries greater than zero will provide additional softkey options that allow use of flow offset profiles on the run screen.

INDIVIDUAL NOZZLE DIAGNOSTICS

To access individual AIM Command FLEX™ control nozzle diagnostic information:



1. Open the UT Menu and select the AIM Command FLEX™ Menu button.
2. Select the Advanced Diagnostics softkey in the desired section.

FIGURE 2. Advanced Nozzle Diagnostics

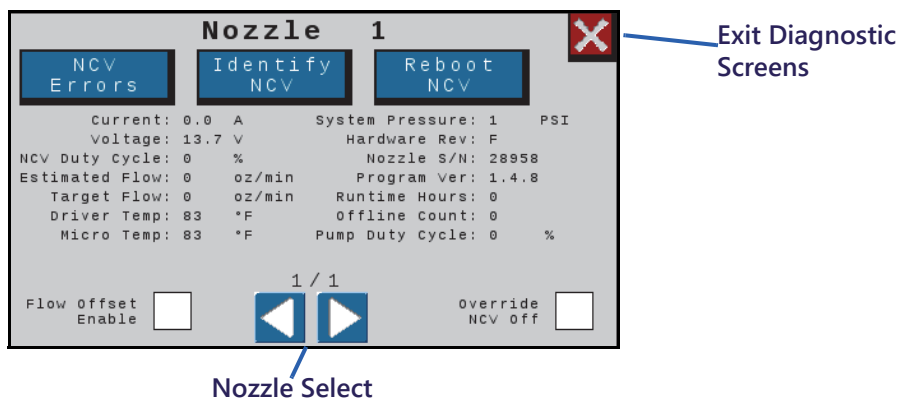

3. Select the Advanced Diagnostics button in the upper, left corner of the Nozzle Diagnostics prompt to access the following diagnostic information for each nozzle:

- Current
- Voltage
- NCV Duty Cycle
- Estimated Flow
- Target Flow
- Driver Temp
- Micro Temp
- Flow Offset Enable
- System Pressure
- Hardware Rev
- Nozzle Serial Number
- Program Version
- Runtime Hours
- Override NCV Off
- Pump Duty Cycle
- Offline Count

NOTE: Use the left and right arrow buttons at the bottom of the nozzle prompt to view different nozzles.

NOZZLE OPERATION INFORMATION

Current and Voltage. Each nozzle control valve provides the measured current, in amperes, and voltage at the nozzle to the AIM Command FLEX™ main Product Controller II ECU for display. Current should be 0.0 Amps when selected NCV is off, and should be 0.3 - 0.7 amps during normal operation. Voltage should be 10.5 - 16.0 V during normal operation.

NCV Duty Cycle. Each nozzle reports the current nozzle duty cycle over the communication network. Values should increase or decrease as expected for changes in speed, target rate, in a turn, and when a flow offset is enabled. Values go to zero when master switch or all boom switches are off.

Estimated Flow. The estimated flow rate through each nozzle is reported to the AIM Command FLEX™ main Product Controller II ECU.

Target Flow. The target flow rate per nozzle for the current application.

Driver Temp and Micro Temp. Component temperatures on the AIM Command FLEX™ nozzle control valve circuit board. These values should be below 40° C during normal operation.

System Pressure. The monitored system pressure reported by the AIM Command FLEX™ spray boom pressure transducer.

Hardware Rev. This is the PCB hardware revision level of the NCV. This is not the same as the assembly revision level which is shown on the NCV label.

Nozzle Serial Number. The nozzle serial number for each nozzle is available on the nozzle diagnostics prompt. This information may be used to help locate specific nozzles on the implement.

Program Version. The version of software loaded on each nozzle. This information may be helpful to troubleshoot individual nozzles or to ensure proper operation of the nozzle control system.

Runtime Hours. The total time which the NCV has been active.

Offline Count. Offline Count indicates the number of times the NCV stopped communicating. This number resets when the power PCII ECU power cycles.

Flow Offset Enable (Wheel Tracks). Check this box to increase the flow rate of any eight nozzles anywhere on the boom to achieve optimal coverage in the turbulent air conditions behind vehicle wheels. The offset percentage compared to the rest of the nozzles is set in the upper diagnostics window (Nozzle Flow Offset%). The maximum offset is 30%.

Override NCV Off. Select Override NCV Off to override the NCV off.

NCV Errors. Displays any errors that the displayed NCV is currently reporting.

Identify NCV. Touch the Identify NCV button to toggle the LED to solid blue. This feature allows the operator to more easily find a specific NCV on the boom.

NOTE: Requires NCV Software 1.4.8 or newer.

Reboot NCV. Reboot and recalibrate the current NCV.

NOTE: Requires NCV Software 1.4.8 or newer.

AIM COMMAND FLEX™ NOZZLE CONTROL VALVE STATUS

FIGURE 1. Nozzle Control Valve LED



TABLE 1. Nozzle Control Valve LED Status Indicator

LED Indicator	Rate	Color	State
Flashing	1 Hz	Green	Ready. If in actuating mode, the NCV is ready but requires calibration.
		Blue	Actuating Mode (Auto)
		Red	Loading New Software
		Amber	Alarm Active
	5 Hz	Amber	No ISOBUS Communication
Alternating	1 Hz	Blue/Green	Actuating Mode (Manual)
		Green/Magenta	Not Calibrated - Switch Input High
		Red/Magenta	Not Calibrated - Switch Input has not Changed
		Amber/Red	No Product Controller II ECU Detected or Invalid ISO Name
		Amber/Green	Ready - Warning Alarm Active
		Amber/Blue	Actuating Mode - Warning Alarm Active
Solid	-	Any	Nozzle Control Valve Failure

NOZZLE TECHNICAL SPECIFICATIONS

TABLE 2. AIM Command FLEX™ Nozzle Control Valve Technical Specifications

		U.S.	Metric
Dimensions	Height	3.8 in.	9.65 cm
	Width	1.39 in.	3.53 cm
	Depth	1.35 in.	3.43 cm
	Weight	approximately 7.1 oz.	approximately 0.2 kg
Power	Operating Voltage	13.6 V DC nominal (10 V drop-out to 16 V spike tolerant)	
Input/Output	CAN	CANBUS 2.0 Compliant.	
	Switched (In/Out)	3V.	
Environmental	Operating Conditions	-22° to 140° F	-30 to 60° C
	Storage Conditions	-40° to 158° F	-40° to 70° C
	Relative Humidity	10 to 95% relative.	

CABLE TROUBLESHOOTING

TROUBLESHOOTING NCV CABLE CONNECTIONS

Nozzle control valve cable troubleshooting may require the system to be powered on and the NCVs disconnected. Disconnecting the NCV should result in Switch Out output to be 0 at the connection and will also result in Nozzle Offline errors that require NCVs to be recalibrated.

Disconnect the boom cable from the nozzle control valve. Hold the connector so that the retention clip is facing toward the 12 o'clock position.

FIGURE 2. Nozzle Control Valve Cable Connector

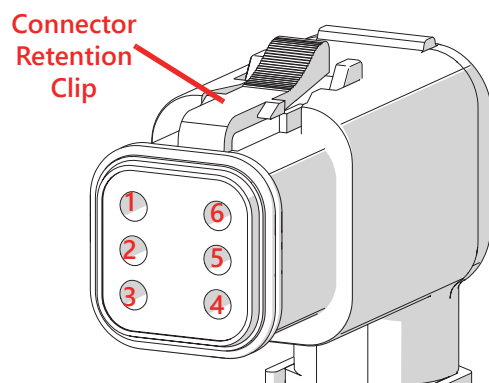

TABLE 3. Nozzle Control Valve Cable Connector Pins

Pin	Description	Pin	Description
1	Chassis Power (10.5 - 16.0 VDC)	6	Chassis Ground (0 VDC)
2	CAN High (2.0 - 2.7 VDC)	5	Switch In (8.0 -13.0 VDC coming from PCII on the first NCVs of the primary cable and 2.5 - 3.2 VDC from previous NCV on all others.)
3	Switch Out (2.5 - 3.2 VDC if NCV connected)	4	CAN Low (2.0 - 2.7 VDC)

TROUBLESHOOTING 19-PIN BOOM CABLE CONNECTIONS

Boom connection cables alternate NCV power and ground circuits within the cable for banks of NCVs. Adjacent NCVs may not necessarily not be on the same HC power and ground circuit. Look at the end of the plug to locate the pin numbers.

TABLE 4. Boom Cable Connection Pins.

Pin	Description	Pin	Description
1	Black CAN GND	11	
2		12	Red HC PWR 2 (10.5 - 16.0 VDC)
3		13	
4	Green CAN LO (2.0 - 2.7 VDC)	14	Black HC GND 2
5	Red CAN PWR (12.0 - 14.0 VDC)	15	
6	Yellow CAN HI (2.0 - 2.7 VDC)	16	Red HC PWR 3 (10.5 -16.0 VDC)
7		17	Green FENCEROW SIG (10.5 - 16.0 VDC)
8	Red HC PWR 1 (10.5 - 16.0 VDC)	18	Black HC GND 3
9		19	Gray SW IN/ENABLE (8.0 - 13.0 VDC or 2.5 -3.2 VDC)
10	Black HC GND 1		

TROUBLESHOOTING TERMINATOR CONNECTIONS

Terminator connection referenced from cable side.

TABLE 5. Terminator Connection Pins

Pin	Description	Pin	Description
A		D	Black CAN GND
B	Red CAN PWR (12.0 - 14.0 VDC)	E	Yellow CAN HI (2.0 - 2.7 VDC)
C		F	Green CAN LO (2.0 - 2.7 VDC)

TROUBLESHOOTING FLOW METER CABLES

Disconnect the extension cable from the flow meter. Hold the extension cable so that the keyway is facing toward the 12 o'clock position.

FIGURE 3. Flow Meter Extension Cable Pin Diagram (Con-X-All)

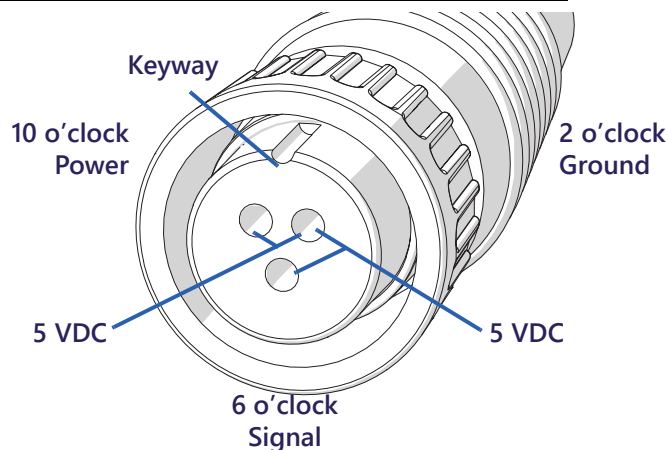

TABLE 6. Flow Meter with Deutsch DT Connector

Pin	Function
A	+ VDC
B	0 VDC
C	Signal Out

TABLE 7. Flow Meter with Deutsch DTM Connector

Pin	Function
1	Signal
2	Ground
3	5 VDC

TEST THE FLOW METER CABLE



To test the flow meter cable:

1. Open the UT Menu and select the AIM Command FLEX™ Menu button.
2. From the home screen, select the Tools Menu softkey along the right side of the display.
3. Select the System Settings tab along the top of the display and select the Product Control Settings button.
4. Enter a value of one for the Meter Cal value.
5. Select the Home softkey along the right side of the display and then select the Tally Registers softkey.
6. Monitor the Total Volume value while testing the cable.
7. Toggle at least one section switch and the master switch to the on position.
8. Use a small jumper wire (e.g. paper clip) to short the ground and signal sockets with a "short-no short" motion. Each time the short is made, the total volume value should change by increments of one or more.
9. If the total volume does not increase, disconnect this section of flow meter extension cable and repeat this test at the next connector closest to Product Controller II ECU. Replace defective cable as required.
10. If all cables test good, replace the flow meter.
11. After testing is complete, re-enter correct meter cal value and units.

DIAGNOSTIC TROUBLE CODE (DTC) LIST

The following trouble codes may be displayed by the AIM Command FLEX™ nozzle control system and should help the operator to identify and correct issues with system during field operations:

Code ID		Description	Recommended Actions
10	.13	UT display is not on-line	<ol style="list-style-type: none"> 1. If this error occurs frequently, check the ISOBUS connections and review the UT display troubleshooting procedures. 2. Connect the Raven Service Tool to the ISOBUS and verify communication.
158	.1	Logic SW power error	<ol style="list-style-type: none"> 1. Verify logic voltage is at or above 4.8 V to Product Controller II ECU.
168	.1	Battery voltage error	<ol style="list-style-type: none"> 1. Verify HC voltage to Product Controller II ECU is above 9 V.
630	.13	System calibration required	<ol style="list-style-type: none"> 1. Complete the calibration wizard to configure all required AIM Command FLEX™ system settings. Refer to Chapter 3, <i>System Calibration</i> for additional assistance with the calibration wizard.
	.31	Nozzle Calibration Error	<ol style="list-style-type: none"> 1. Complete the calibration wizard to configure all required AIM Command FLEX™ system settings. Refer to Chapter 3, <i>System Calibration</i> for additional assistance with the calibration wizard. 2. Cycle system power. 3. Reset defaults.
1563	.2	Nozzle control valves incompatible with product controller/AIM Command FLEX™ Product Controller II ECU	<ol style="list-style-type: none"> 1. Check for Product Controller II ECU software updates. 2. Check for nozzle control valve software updates. 3. Cycle system power. 4. Reset defaults.
	.17	NCV programming out of date	<ol style="list-style-type: none"> 1. Check for nozzle control valve software version differences. Update the nozzle control valves to a consistent software version. Refer to the Raven Service Tool Operation manual for assistance with the nozzle update procedure.
	.31	Inconsistent nozzle control valve software version	<ol style="list-style-type: none"> 1. Check for nozzle control valve software version differences. Update the nozzle control valves to a consistent software version. Refer to the Raven Service Tool Operation manual for assistance with the nozzle update procedure.

Code ID	Description	Recommended Actions	
523232	.0	Maximum pressure exceeded	1. Relieve pressure from system. Check the boom pressure transducer calibration settings.
	.1	System pressure not detectable.	1. Activate product pump. 2. Check for system leaks. 3. Increase pump output to maintain a boom pressure above 2 PSI [13.8 kPa].
	.4	Pressure transducer not detected	1. Check the pressure transducer connection. 2. Check the transducer cabling for damage and replace the cable if necessary.
	.13	Pressure transducer not calibrated	1. Refer to the <i>Tools Menu Settings Definitions</i> section on page 18 for assistance with the pressure transducer calibration.
	.15	Monitored system pressure higher than maximum pressure set-point	1. Reduce the equipment speed. 2. Refer to the <i>System Settings Tab - Pressure</i> section on page 29 for assistance with adjusting the maximum pressure set-point.
	.16	Monitored system pressure higher than the target pressure deadband	1. Reduce the equipment speed. 2. Refer to the <i>Pressure 1 and 2 Presets</i> section on page 27 for assistance with setting or adjusting the target pressure. 3. Refer to the <i>System Settings Tab - Pressure</i> section on page 29 for assistance with setting or adjusting the off pressure percent.
	.17	Monitored system pressure lower than minimum pressure set-point	1. Increase the equipment speed. 2. Refer to the <i>System Settings Tab - Pressure</i> section on page 29 for assistance with adjusting the minimum pressure set-point.
4305	.18	Monitored system pressure lower than the target pressure deadband	1. Increase the equipment speed. 2. Refer to the <i>Pressure 1 and 2 Presets</i> section on page 27 for assistance with setting or adjusting the target pressure. 3. Refer to the <i>Pressure 1 and 2 Presets</i> section on page 27 for assistance with setting or adjusting the off pressure percent.
	.2	Equipment speed is below operational range	1. Increase vehicle speed.

Code ID		Description	Recommended Actions
523013	.2	Nozzle indexing error	<ol style="list-style-type: none"> 1. Check that all nozzle control valves are connected to the boom harness. 2. Verify nozzle counts on left and right booms. 3. Check nozzle control valve diagnostics or status LEDs to identify valve is causing error. 4. Restart the calibration wizard and complete the nozzle indexing to properly set the nozzle control valve locations across the implement. 5. Check the terminator cables for bare or worn wires. 6. Check the CAN voltages on the boom cables. 7. Reload the object pool and disconnect power to the machine.
	.3	Nozzle offline	<ol style="list-style-type: none"> 1. Cycle system power. 2. Verify the correct total number of nozzles are detected and their information is present in the diagnostics information tab. 3. Check LED lights on the NCVs <i>AIM Command FLEX™ Nozzle Control Valve Status</i> section on page 53. 4. Check the NCVs, connections, relays, cables, and fuses for damage. 5. Recalibrate the NCVs.
	.16	Too many nozzles detected	<ol style="list-style-type: none"> 1. Restart the calibration wizard and verify the number of nozzle control valves connected to the AIM Command FLEX™ nozzle control system. 2. Cycle system power. 3. Reset defaults.
	.31	CAN errors detected on NCV CANbus.	<ol style="list-style-type: none"> 1. Check nozzle bus termination. 2. Inspect NCV cabling. 3. Inspect individual NCV connections for corrosion or damage.
520592	.5	NB HS current low single	<ol style="list-style-type: none"> 1. Reduce operating speed. 2. Verify the NCV voltage is above 10.5 V. 3. Check the system cabling for damage. 4. Check the NCV duty cycle for proper operation. 5. Contact a local Case IH dealer if the issue is not resolved.
	.6	NB HS current high single	<ol style="list-style-type: none"> 1. Reduce operating speed. 2. Verify the NCV voltage is above 10.5 V. 3. Check the system cabling for damage. 4. Check the NCV duty cycle for proper operation. 5. Contact a local Case IH dealer if the issue is not resolved.

Code ID		Description	Recommended Actions
520593	.5	NB HS current low multiple	<ol style="list-style-type: none"> 1. Reduce operating speed. 2. Verify the NCV voltage is above 10.5 V. 3. Check the system cabling for damage. 4. Check the NCV duty cycle for proper operation. <ol style="list-style-type: none"> 1. Contact a local Case IH dealer if the issue is not resolved.
	.6	NB HS current high multiple	<ol style="list-style-type: none"> 1. Reduce operating speed. 2. Verify the NCV voltage is above 10.5 V. 3. Check the system cabling for damage. 4. Check the NCV duty cycle for proper operation. <ol style="list-style-type: none"> 1. Contact a local Case IH dealer if the issue is not resolved.
523008	.2	Nozzle calibration tip mismatch/error	<ol style="list-style-type: none"> 1. Select the appropriate tip type. Refer to the <i>Injection Pump Efficiency</i> section on page 42 for additional assistance. 2. Restart the calibration wizard to reset the tip type setting for the nozzle control system. 3. Cycle system power and reset defaults.
	.31	No NCV tip size selected	<ol style="list-style-type: none"> 1. Enter a NCV tip size into the calibration summary tab.
523009	.2	Nozzle calibration spacing mismatch/error	<ol style="list-style-type: none"> 1. Restart the calibration wizard to re-enter the tip spacing measurement. 2. Cycle system power. 3. Reset defaults.
523088	.12	Nozzle memory error (single)	<ol style="list-style-type: none"> 1. Restart the calibration wizard. 2. Cycle system power. 3. Reset defaults. 4. Contact a local Case IH dealer for additional assistance.
	.31	Nozzle memory warning (single)	<ol style="list-style-type: none"> 1. Restart the calibration wizard. 2. Cycle system power. 3. Reset defaults. 4. Contact a local Case IH dealer for additional assistance.
523089	.12	Nozzle memory error (single)	<ol style="list-style-type: none"> 1. Restart the calibration wizard. 2. Cycle system power and reset defaults. 3. Contact a local Case IHdealer for additional assistance.
	.31	Nozzle memory warning (multiple)	<ol style="list-style-type: none"> 1. Restart the calibration wizard. 2. Cycle system power. 3. Reset defaults. 4. Contact a local Case IHdealer for additional assistance.

Code ID		Description	Recommended Actions
523090	.1	Nozzle calibration error (single)	<ol style="list-style-type: none"> 1. Restart the calibration wizard to recalibrate the nozzle control system. 2. Cycle system power. 3. Reset defaults.
523091	.1	Nozzle calibration error (multiple)	<ol style="list-style-type: none"> 1. Restart the calibration wizard to recalibrate the nozzle control system. 2. Cycle system power. 3. Reset defaults.
523092	.31	No tip information entered for nozzle control valve (single)	<ol style="list-style-type: none"> 1. Select the appropriate tip type. Refer to <i>Injection Pump Efficiency</i> section on page 42 for additional assistance. 2. Restart the calibration wizard to reset the tip type setting for the nozzle control system.
523093	.31	No tip information entered for nozzle control valves (multiple)	<ol style="list-style-type: none"> 1. Restart the calibration wizard to configure tip information for the AIM Command FLEX™ nozzle control valves.
523126	.13	Unable to detect AIM Command FLEX™ Product Controller II ECU orientation	<ol style="list-style-type: none"> 1. Check the Product Controller II ECU mounting position and verify the Product Controller II ECU is securely mounted. 2. Recalibrate the Product Controller II ECU gyro.
523136	.16	Monitored flow rate is higher than the target rate deadband	<ol style="list-style-type: none"> 1. Reduce the equipment speed. 2. Review "Avoiding Skips with AIM Command FLEX™ Nozzle Control System" section on page 69. 3. Refer to the <i>AIM Command FLEX™ Upper Home Screen</i> section on page 40 for assistance with setting or adjusting the target rate. 4. Refer to the <i>System Settings Tab - Alarm</i> section on page 25 for assistance with setting or adjusting the off rate percent.
	.18	Monitored flow rate is lower than the target rate deadband	<ol style="list-style-type: none"> 1. Increase the equipment speed. 2. Refer to the <i>AIM Command FLEX™ Upper Home Screen</i> section on page 40 for assistance with setting or adjusting the target rate. 3. Refer to the <i>System Settings Tab - Alarm</i> section on page 25 for assistance with setting or adjusting the off rate percent.
523137	.18	Minimum flow not met	<ol style="list-style-type: none"> 1. Activate product pump. 2. Review "Avoiding Skips with AIM Command FLEX™ Nozzle Control System" section on page 69. 3. Increase pump output to maintain the minimum recommended flow rate for each nozzle control valve.

Code ID		Description	Recommended Actions
523192	.13	Spurge pressure transducer not calibrated	1. Refer to the "Tools Menu Settings Definitions" on page 18 for assistance with pressure transducer calibration.
	.14	New injection pump detected	1. A new injection pump was detected.
	.15	Injection pump lost communication	1. Verify the LED's on the injection pump are on. 2. Check the CAN connections of the injection device. 3. Connect the Raven Service Tool to the ISOBUS and verify communication.
523193	.16	High system efficiency	1. Check the plumbing system for leaks. 2. Check the pressure transducer calibration. 3. Check the flow meter calibration value. 4. Verify the fencerow outputs are not active. 5. Check the NCVs for debris or seal for wear.
	.18	Low system efficiency	1. Check the pressure transducer calibration. 2. Check the flow meter calibration value. 3. Check the NCVs for debris or seal deformation.
523520	.31	Invalid flow meter calibration	1. Enter a valid flow meter calibration value.
523906	.17	Equipment speed below the speed range (single nozzle)	1. Increase equipment speed to the range displayed on the AIM Command FLEX™ home screen. Refer to the <i>AIM Command FLEX™ Upper Home Screen</i> section on page 40 and <i>AIM Command FLEX™ Lower Home Screen</i> section on page 43 for assistance with the information provided on the home screen.
523907	.17	Equipment speed below the speed range (multiple nozzles)	1. Increase equipment speed to the range displayed on the AIM Command FLEX™ home screen.
523908	.15	Equipment speed above the speed range (single nozzle)	1. Reduce equipment speed to the range displayed on the AIM Command FLEX™ home screen.
523909	.15	Equipment speed above the speed range (multiple nozzles)	1. Reduce equipment speed to the range displayed on the AIM Command FLEX™ home screen. Refer to the <i>AIM Command FLEX™ Upper Home Screen</i> section on page 40 and <i>AIM Command FLEX™ Lower Home Screen</i> section on page 43 for assistance with the information provided on the home screen.
523910	.31	Nozzle power/temperature error (single)	1. Check for clogs in valve or associated plumbing that may be preventing liquid flow through the valve.
523911	.31	Nozzle power/temperature error (multiple)	1. Check for restrictions in valves or associated plumbing that may be preventing liquid flow through the valve.

Code ID		Description	Recommended Actions
523912	.31	NB voltage low single	<ol style="list-style-type: none"> 1. Reduce operating speed. 2. Verify the NCV voltage is above 10.5 V. 3. Check the system cabling for damage. 4. Check the NCV duty cycle for proper operation. 5. Contact a local AIM Command FLEX™ dealer if the issue is not resolved.
523913	.31	NB voltage low multi	<ol style="list-style-type: none"> 1. Reduce operating speed. 2. Verify the NCV voltage is above 10.5 V. 3. Check the system cabling for damage. 4. Check the NCV duty cycle for proper operation. 5. Contact a local AIM Command FLEX™ dealer if the issue is not resolved.
523914	.31	Nozzle Product Controller II ECU no master single	<ol style="list-style-type: none"> 1. Verify the NCV voltage is above 10.5 V. 2. Check the system cabling for damage. 3. Contact a local AIM Command FLEX™ dealer if the issue is not resolved.
523915	.31	Nozzle Product Controller II ECU no master multiple	<ol style="list-style-type: none"> 1. Verify the NCV voltage is above 10.5 V. 2. Check the system cabling for damage. 3. Contact a local AIM Command FLEX™ dealer if the issue is not resolved.
523916	.31	Single poppet stuck	<ol style="list-style-type: none"> 1. Inspect the NCVs for obstruction or restrictions. Clean if necessary. 2. Verify the strainers are 80 mesh.
523917	.31	Multiple stuck poppets	<ol style="list-style-type: none"> 1. Inspect the NCVs for obstruction or restrictions. Clean if necessary. 1. Verify the strainers are 80 mesh.
524080	.2	Lost communication with switch box	<ol style="list-style-type: none"> 1. Check Raven ISOBUS switch box connections if installed, power LED located on front of the switch box should be on. 2. Connect the Raven Service Tool to the ISOBUS and verify communication. 3. Cycle power to system.
524081	.13	Switchbox not calibrated	<ol style="list-style-type: none"> 1. A switchbox was added after calibration was complete. Re-calibrate the system with the switchbox connected.

Code ID		Description	Recommended Actions
4294967295	.1	Incompatible hardware	<ol style="list-style-type: none"> 1. Reset defaults. 2. Recalibrate the system. 3. See AIM Command FLEX™ dealer for assistance.
		NB unknown error single	<ol style="list-style-type: none"> 1. Reset defaults. 2. Recalibrate the system. 1. See AIM Command FLEX™ dealer for assistance.
		NB unknown error multi	<ol style="list-style-type: none"> 1. Reset defaults. 2. Recalibrate the system. 1. See AIM Command FLEX™ dealer for assistance.
		I2C init	<ol style="list-style-type: none"> 1. Reset defaults and recalibrate system. 2. See AIM Command FLEX™ dealer for additional assistance.
		Gyro sensor not initialized	<ol style="list-style-type: none"> 1. Check the Product Controller II ECU mounting position and verify the Product Controller II ECU is securely mounted. 1. Recalibrate the Product Controller II ECU gyro.
		Accelerometer not initialized	<ol style="list-style-type: none"> 1. Check the Product Controller II ECU mounting position and verify the Product Controller II ECU is securely mounted. 1. Recalibrate the Product Controller II ECU gyro.
.31	Chemical tank is filling	<ol style="list-style-type: none"> 1. The remote chemical tank fill switch is active. 	
	Section control is not unlocked	<ol style="list-style-type: none"> 1. Verify section control is unlocked in the UT or Task Controller. See UT or task controller dealer for assistance. 	
	Diagnostic application in control	<ol style="list-style-type: none"> 1. Verify a wireless device is in control of the system. 	

GENERAL TROUBLESHOOTING

Problem	Action
Adjacent nozzle control valves pulsing at same time.	<ul style="list-style-type: none"> • Check cabling connections. • Check nozzle diagnostics and DTC list for nozzle control valve errors. • Restart the calibration wizard to reindex the nozzle control valves across the implement width. • Contact a local AIM Command FLEX™ dealer for additional assistance.
Rate reads "0."	<ul style="list-style-type: none"> • Verify SPEED is registering accurately. If SPEED is zero, refer to the UT display troubleshooting procedure. • Verify TOTAL VOLUME is registering flow. • Confirm the boom section status shows on the display changes when section switches are activated in manual operation.

Problem	Action
Pressure or rate inaccurate or unstable.	<ul style="list-style-type: none"> • Verify that all calibration numbers and settings keyed into the console are correct. Verify SPEED is registering accurately. If SPEED is inaccurate, refer to the UT display troubleshooting procedure. • Verify the pressure transducer is selected and calibrated correctly. • Verify Flow Meter calibration value and target rate is within overall flow range. • In MAN (manual) operation, verify that Pressure and Rate display holds constant. • Confirm that boom section status shown on the display is not changing. • Perform a self-test with boom master switches on to verify the area/hour is steady while sitting still. • In MAN (manual) operation, check low end and high end pressure and flow range. • In the Pressure Control Settings menu, decrease the Response Rate if pressure and rate oscillate greatly in AUTO mode. Increase the pressure response rate if control is unresponsive. • In the Product Control Settings menu, decrease response sensitivity if system pressure and rate oscillate slightly in AUTO mode. Increase if the system is unresponsive. Avoid Pressure Response Rate and Product Response Sensitivity both above 70.
Cannot adjust rate or pressure in automatic or manual operation.	<ul style="list-style-type: none"> • Verify the pump switch is turned on in the UT or machine console. • Verify the pump and NCV PWM values are increasing or decreasing in the diagnostic screen. • Check cabling to control valve for breaks. • Check connections in cabling for cleanliness. • Verify that there is voltage at the valve connector by toggling master switch on and setting the system to Manual. Manually change pump PWM and verify voltage changes at the valve. • If voltage to the valve is changing smoothly when actuating in Manual mode, but the control valve or pump are not adjusting pressure, inspect or replace the control valve or pump.
Sprayer pressure is correct but RATE is low.	<ul style="list-style-type: none"> • Verify that nozzle strainer screens or check valves are not plugged. • Verify that pressure at each boom is the same. • Verify all nozzles are of proper and same orifice size. • Verify correct flow meter and pressure transducer calibration values.

Problem	Action
Total volume does not register or registers flow inaccurately.	<ul style="list-style-type: none"> • Check flow meter/encoder cable for breaks and shorts. See the <i>Cable Troubleshooting</i> section on page 54. • Check the internal components of the flow meter; clean and adjust. Appendix C, <i>Maintenance Schedule and Replacement Parts</i> for flow meter cleaning and adjustments. • Replace flow meter transducer/encoder. • Verify that arrow on flow meter is pointing in direction of flow. • Verify the flow meter calibration value and units and adjust as necessary. Refer to the <i>Flow Meter Cal</i> section on page 19 for additional flow meter calibration information.
Boom valve(s) will not operate.	<ul style="list-style-type: none"> • Check cable for wires with breaks. • Verify the switches and boom valves are mapped correctly. • Check connectors for cleanliness. • Check BOOM switch and MASTER switch for operation. • Replace boom valves.
Pressure inaccurate or unstable.	<ul style="list-style-type: none"> • Verify the correct pressure for the transducer is selected. • In Pressure Settings, lower the Response Rate to stabilize the system. • Verify the pressure on UT matches separate external mechanical gauge.
Individual nozzle will not communicate with Raven Service Tool Action	<ul style="list-style-type: none"> • Verify power to the nozzle. • Verify the NCV cable connection voltages fall within the desired range. • Cycle power to the system. • Recalibrate the system. • Replace the NCV.
Cannot detect BLE (Blue-tooth low energy) device for diagnostics	<ul style="list-style-type: none"> • Verify Bluetooth functionality is turned on for mobile device. • Verify another mobile device isn't already connected to the Product Controller II ECU. • Verify that the mobile device is BLE compatible running ISO version 8.1 or newer or Android Version 5 or newer. • Verify the mobile device is within line of sight to the Product Controller II ECU.
Cannot connect to BLE (Blue-tooth low energy) device for diagnostics	<ul style="list-style-type: none"> • Verify mobile devices is within line of sight to the Product Controller II ECU. • Verify device Wireless ID on Product Controller II ECU System Information screen. • Verify a Device Passcode entered into mobile device matches passcode shown on System Alert.

Problem	Action
Intermittent connection to BLE (Blue-tooth low energy) devices	<ul style="list-style-type: none"> • Verify mobile device is within line of sight to Product Controller II ECU. • Verify the mobile device Diagnostic app is open.
Cannot control with mobile device	<ul style="list-style-type: none"> • Verify mobile device is connected to Product Controller II ECU. • Verify the Enable Wireless Control checkbox is selected in User Settings screen on Product Controller II ECU. • Verify system speed in "0" on the main Product Controller II ECU screen. • Verify all boom section switches and master switch are toggled "ON" on the machine control panel or joystick.

AVOIDING SKIPS WITH AIM COMMAND FLEX™ NOZZLE CONTROL SYSTEM

OVERVIEW

The AIM Command FLEX™ nozzle control system is designed to pulse each spray tip using an alternating pattern across the implement width. This alternating nozzle spray pattern relies upon an overlapping spray tip pattern and droplet dispersion to achieve complete and even coverage during field applications.

RECOMMENDATIONS FOR AIM COMMAND FLEX™ NOZZLE CONTROL OPERATION

Maintain the following application system conditions will help to ensure consistent, even coverage during field applications using the AIM Command FLEX™ nozzle control system:

1. Use the appropriate tip size for the desired droplet size, application speeds, target rates, and system pressures. Refer to the tables in the *Tip Selection and Application Speed Guide* section on page 72.
2. Use wide-angle spray tips and appropriate spray tip height to achieve approximately 150% pattern overlap.
 - a. When using 80° spray tips:
 - 20" spacing have a minimum spray tip height of 36" [91.4 cm]
 - 15" spacing have a minimum spray tip height of 27" [68.6 cm]
 - 10" spacing have a minimum spray tip height of 18" [45.7 cm]
 - b. When using 110° spray tips:
 - 20" spacing have a minimum spray tip height of 21" [53.3 cm]
 - 15" spacing have a minimum spray tip height of 16" [40.6 cm]
 - 10" spacing have a minimum spray tip height of 10" [25.4 cm]
3. Maintain a system pressure sufficient to fully develop the intended tip spray pattern.
4. Avoid nozzle control valve duty cycles below 25%.
 - a. Stay within the displayed speed range for a selected tip size, application rate, and pressure.
 - b. Avoid application speeds in the bottom 1/3 of the recommended speed range.
 - c. Avoid target flow rates in the bottom 1/3 of the recommended application rate range for each spray tip.
 - d. When turn compensation is active, make gradual turns to avoid operating the NCVs at their limits.
5. Target application speeds, tip sizes, and operating pressures so the NCVs operate at approximately 70% ± 10% duty cycle on average for the desired spray droplet size.

FOR EXAMPLE:

Consistent and even field coverage should result under the following application conditions:

- applicator with 20 inch [50.8 cm] nozzle spacing
- 110° fan spray tips at 50 PSI [344.7 kPa]
- application speed of 15 mph [24.1 km/h]
- spray tip height of 21 inches [53.3 cm]

FIGURE 1. Alternating Spray Pattern and Even Area Coverage

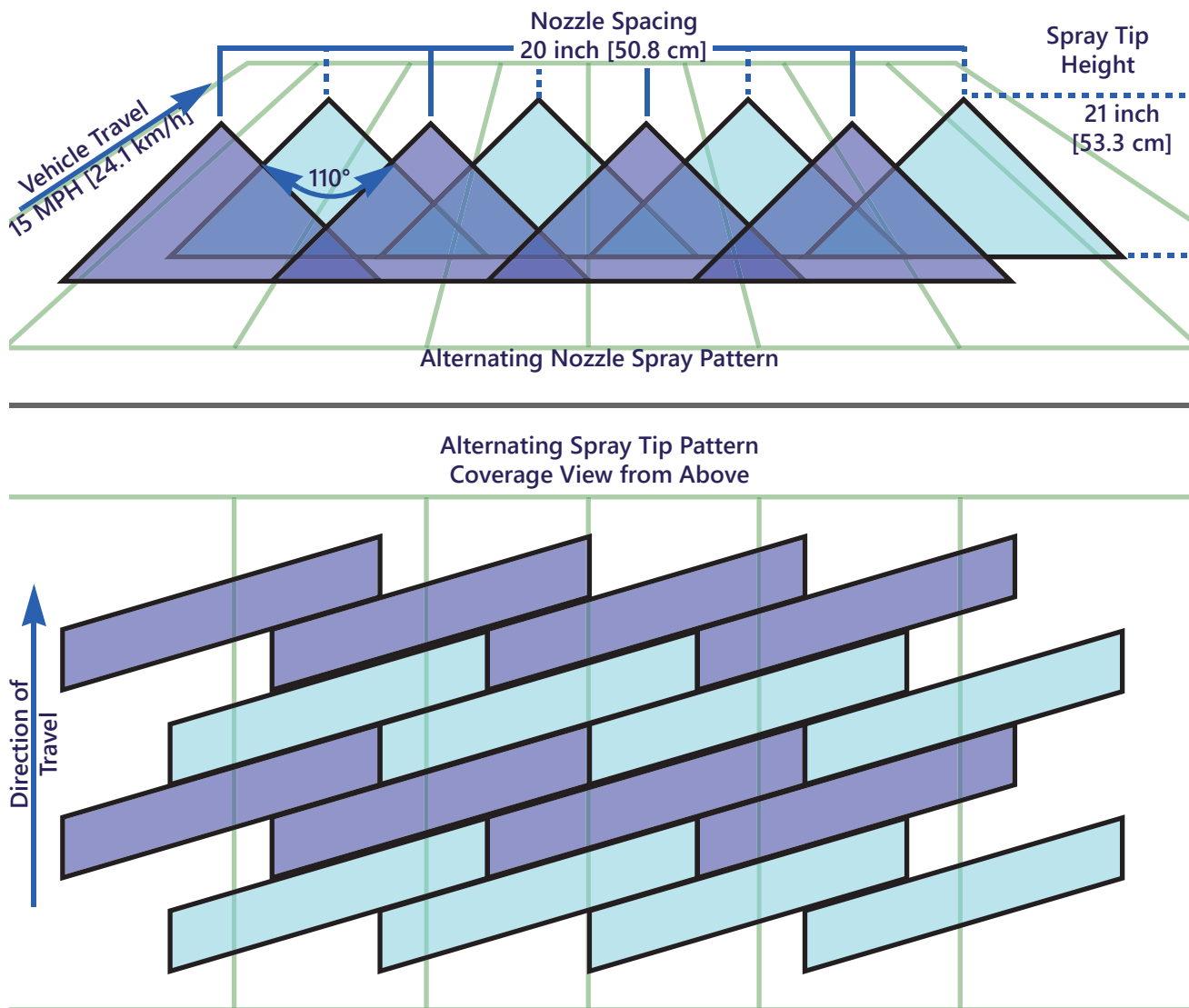

NOTE: In Automatic control mode, the AIM Command FLEX™ nozzle control system will adjust the system to maintain the optimal application coverage within the operational ranges provided in the *Tip Selection and Application Speed Guide* section on page 72.

CAUSES OF SKIPS USING AIM COMMAND FLEX™ NOZZLE CONTROL

Operating the AIM Command FLEX™ nozzle control system at or outside of the recommended operational ranges may result in under-application or banding.

FOR EXAMPLE:

Under-application or horizontal banding may be observed if the operator from the previous example were to toggle the application mode from Automatic to Manual and then increase the application speed from 15 mph [24.1 km/h] to 22 mph [35.4 km/h] without manually increasing the nozzle control valve duty cycle.

FIGURE 2. Conditions Resulting in Under-Application and Horizontal Banding

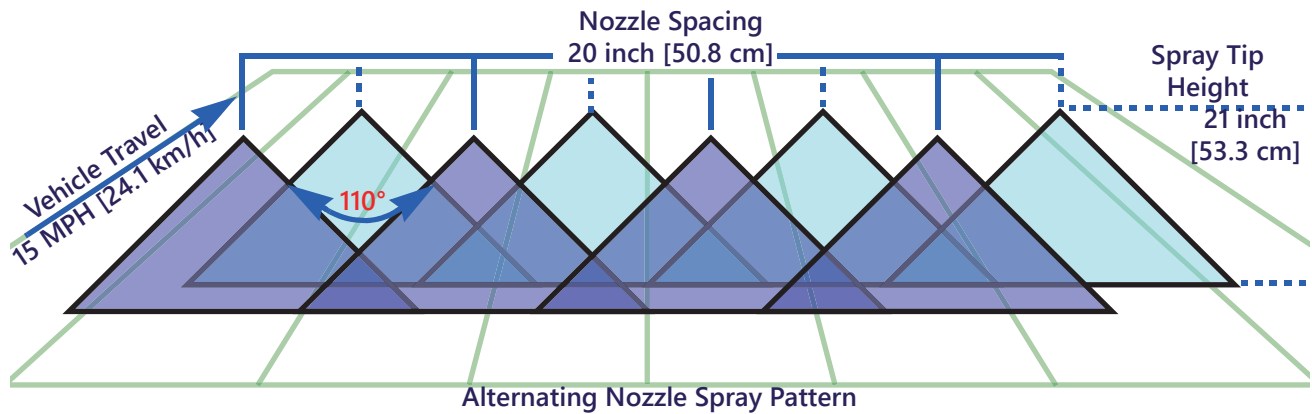

Alternating Spray Tip Pattern
Coverage View from Above

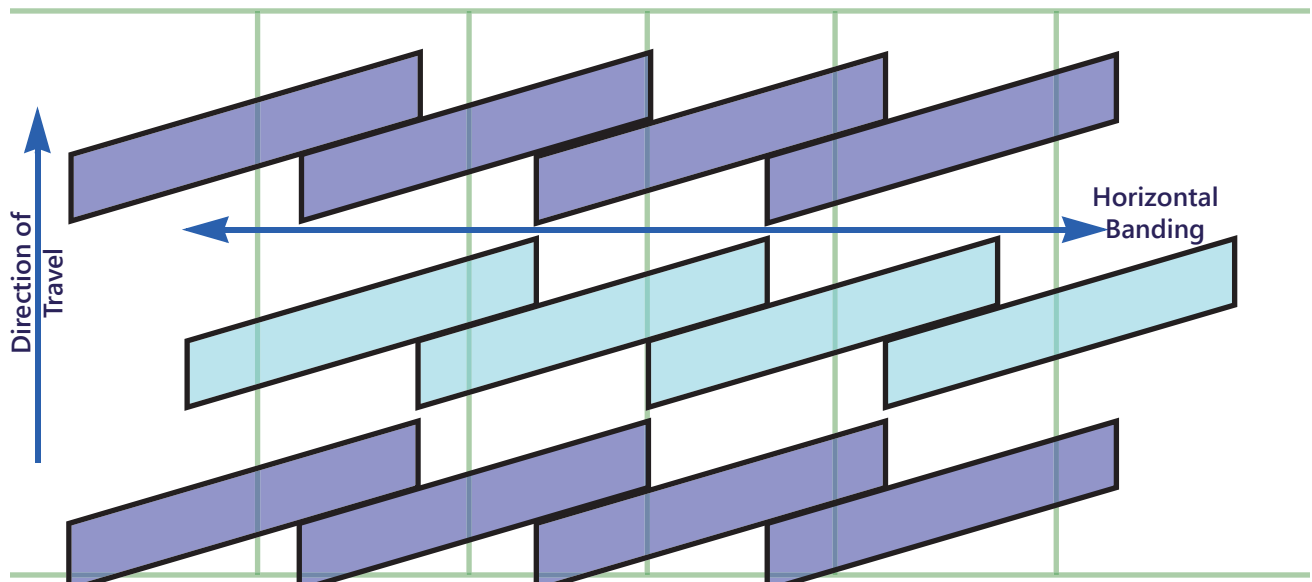

FOR EXAMPLE:

Under-application with diagonal banding may be observed if the following modification to the initial example are made:

- Using 80° fan spray tips at a height of 21 inches [53.3 cm].
- Boom pressure is too low resulting in the nozzle tip not being able to achieve full spray pattern.

NOTE: Refer to *Recommendations for AIM Command FLEX™ Nozzle Control Operation* section on page 69 and recall the recommended spray height for 80° spray tips. Refer to *Tip Selection and Application Speed Guide* section on page 72 for boom and spray tip pressure recommendations.

FIGURE 3. Conditions Resulting in Under Application and Diagonal Banding

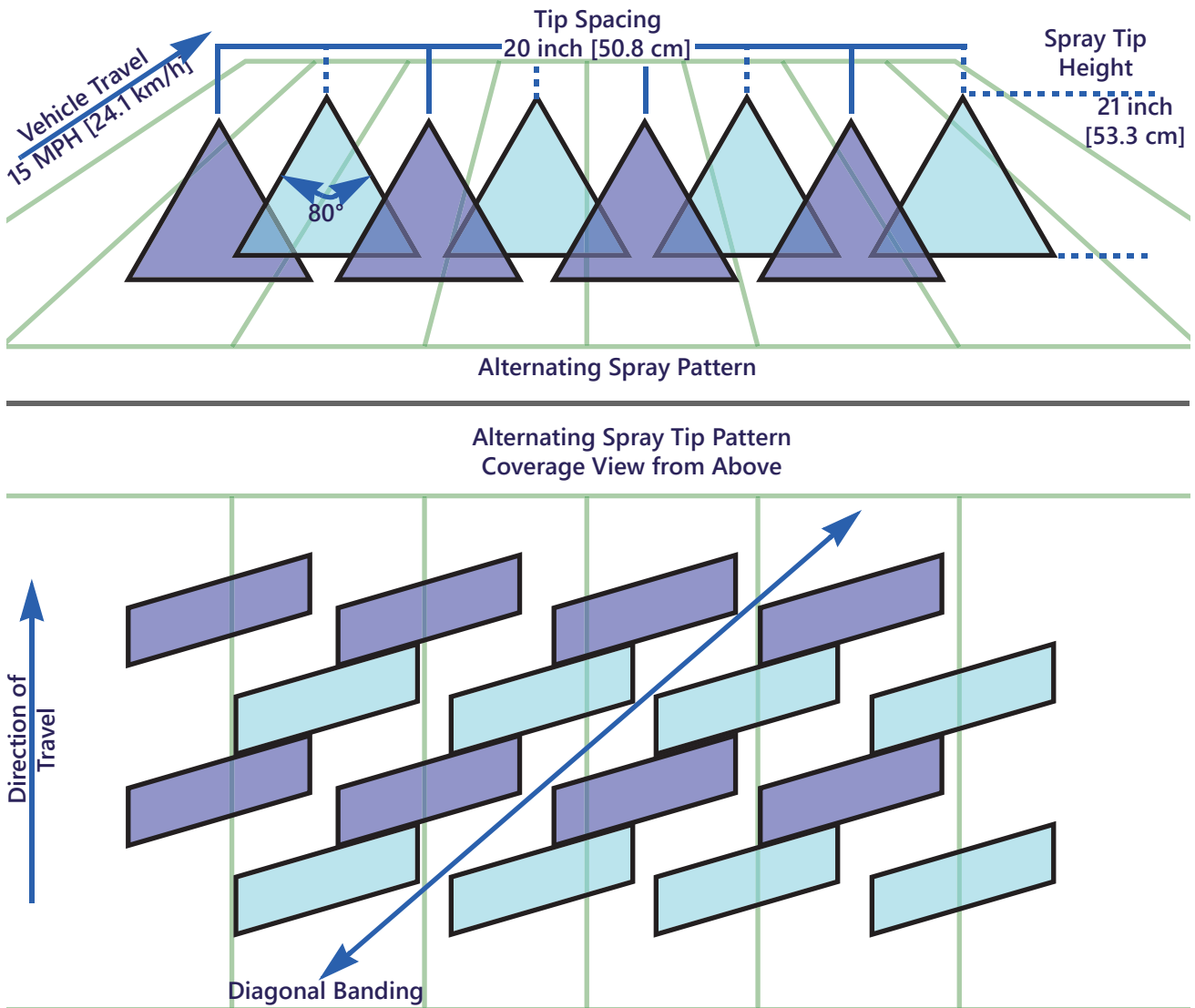

TIP SELECTION AND APPLICATION SPEED GUIDE

DRIFT CONTROL AND DROPLET SIZING

The table below shows the drift control specifications for different nozzle manufacturers. Use this information when selecting the appropriate nozzles for your application.

To properly size spray tip and type, determine the typical spray speed, target pressure for desired droplet size, and target rate for application.

FOR EXAMPLE: If the desired target rate is 10 GPA at 15 mph with a medium desired droplet size:

- For conventional spraying, the tip chart recommends using an 05 spray tip at 40 PSI.
- For pulsing nozzles with a target of 70% ± 10% duty cycle, use a 06 or 08 tip. At 40 PSI either tip would create the desired droplet size.

TABLE 1. Nozzle Drift Control by Manufacturer.

Tip Size	Boom Pressure (PSI)	Wilger (www.wilger.net)				TeeJet (www.teejet.com)			Hypro (www.hypropumps.com)				
Orifice Size	PSI	ER	SR	MR	DR	XR/XRC	TT/2XTT	TT160	HF	GRD	LD	VP	TR
	Gauge	110	110	110	110	110	110	110	110	110	110	110	120
03	20	M	-	C	-	M	VC	VC	-	M	M	F	M
	30	M	C	VC	XC	F	C	C	-	M	M	F	F
	40	F	C	VC	XC	F	C	C	-	M	M	F	F
	50	F	C	C	VC	F	M	C	-	M	M	F	F
	60	F	C	C	VC	F	M	C	-	M	M	F	F
04	20	C	-	-	-	M	VC	VC	-	C	C	M	M
	30	C	C	VC	XC	M	C	C	-	C	C	M	M
	40	M	C	VC	XC	M	C	C	-	C	M	F	F
	50	M	C	C	XC	F	M	C	-	M	M	F	F
	60	M	C	C	VC	F	M	C	-	M	M	F	F
05	20	C	-	-	-	M	VC	VC	-	C	C	M	C
	30	C	VC	XC	XC	M	VC	C	-	C	C	M	M
	40	M	C	XC	XC	M	C	C	-	C	M	F	F
	50	M	C	VC	XC	F	C	C	-	M	M	F	F
	60	M	C	VC	XC	F	M	C	-	C	C	F	M
06	20	C	-	-	-	M	VC	XC	-	VC	VC	M	C
	30	C	VC	XC	XC	M	VC	VC	-	C	C	M	C
	40	C	VC	XC	XC	M	VC	C	-	C	C	M	M
	50	C	C	XC	XC	M	C	C	-	C	C	F	M
	60	C	C	VC	XC	F	C	C	-	C	C	F	M
08	20	C	-	-	-	C	VC	-	UC	VC	VC	C	C
	30	C	XC	XC	XC	C	VC	-	UC	C	C	M	C
	40	C	VC	XC	XC	M	C	-	UC	C	C	M	M
	50	C	VC	XC	XC	M	C	-	UC	C	C	M	M
	60	C	C	VC	XC	M	C	-	XC	C	C	M	M
10	30	C	XC	XC	UC	C	-	-	UC	-	-	C	VC
	40	C	VC	XC	UC	M	-	-	UC	-	-	C	C
	50	C	VC	XC	XC	M	-	-	UC	-	-	M	M
	60	C	VC	VC	XC	M	-	-	XC	-	-	M	M
12.5	40	VC	VC	XC	XC	-	-	-	-	-	-	-	-
	50	C	VC	XC	XC	-	-	-	-	-	-	-	-
	60	C	VC	XC	XC	-	-	-	-	-	-	-	-

Tip Size	Boom Pressure (PSI)	Wilger (www.wilger.net)				TeeJet (www.teejet.com)			Hypro (www.hypropumps.com)				
Orifice Size	PSI	ER	SR	MR	DR	XR/XRC	TT/2XTT	TTJ60	HF	GRD	LD	VP	TR
	Gauge	110	110	110	110	110	110	110	110	110	110	110	120
15	40	VC	XC	XC	XC	C	-	-	UC	-	-	VC	VC
	50	C	XC	XC	XC	C	-	-	UC	-	-	C	C
	60	C	XC	XC	XC	C	-	-	XC	-	-	M	M

DRIFT CONTROL TABLE KEY

Refer to this key while using the drift control table:

TABLE 2. Number Key

Drift Category	Symbol and Color
Very Fine	VF
Fine	F
Medium	M
Coarse	C
Very Coarse	VC
Extremely Coarse	XC
Ultra Course	UC

APPLICATION SPEED GUIDE

The ranges for speed and flow rate provided in this section are for reference purposes only. Observed ranges may vary depending upon application system plumbing and hardware. It is recommended to avoid operating at, or close to, the upper and lower limits of the speed or flow rate ranges shown for each spray tip. The values in the table below are based on 20" nozzle spacing.

TABLE 3. Speed Table for Standard (Straight) Style Nozzle Bodies (Imperial)

Tip Size	Boom Pressure (PSI)	Speed Range (MPH)											
		3 GPA		5 GPA		8 GPA		10 GPA		15 GPA		20 GPA	
015	20.0	5.4	10.6	3.2	6.3	2.0	4.0	1.6	3.2	1.1	2.1	0.8	1.6
	30.0	6.0	12.9	3.6	7.8	2.2	4.8	1.8	3.9	1.2	2.6	0.9	1.9
	40.0	6.5	14.9	3.9	9.0	2.4	5.6	1.9	4.5	1.3	3.0	1.0	2.2
	50.0	6.9	16.7	4.1	10.0	2.6	6.3	2.1	5.0	1.4	3.3	1.0	2.5
	60.0	7.33	18.3	4.4	11.0	2.7	6.9	2.2	5.5	1.5	3.7	1.1	2.7
02	20.0	6.2	13.7	3.7	8.2	2.3	5.1	1.8	4.1	1.2	2.7	0.9	2.1
	30.0	6.9	16.8	4.2	10.1	2.6	6.3	2.1	5.0	1.4	3.4	1.0	2.5
	40.0	7.6	19.4	4.5	11.7	2.8	7.3	2.3	5.8	1.5	3.9	1.1	2.9
	50.0	8.2	21.7	4.9	13.0	3.1	8.1	2.4	6.5	1.6	4.3	1.2	3.3
	60.0	8.7	23.8	5.2	14.3	3.3	8.9	2.6	7.1	1.7	4.8	1.3	3.6
025	20.0	7.1	17.4	4.2	10.4	2.7	6.5	2.1	5.2	1.4	3.5	1.1	2.6
	30.0	8.0	21.3	4.8	12.8	3.0	8.0	2.4	6.4	1.6	4.3	1.2	3.2
	40.0	8.9	24.6	5.3	14.8	3.3	9.2	2.7	7.4	1.8	4.9	1.3	3.7
	50.0	9.6	27.5	5.8	16.5	3.6	10.3	2.9	8.2	1.9	5.5	1.4	4.1
	60.0	10.3	30.1	6.2	18.1	3.8	11.3	3.1	9.0	2.1	6.0	1.5	4.5
03	20.0	7.9	20.6	4.7	12.4	3.0	7.7	2.4	6.2	1.6	4.1	1.2	3.1
	30.0	9.0	25.3	5.4	15.2	3.4	9.5	2.7	7.6	1.8	5.1	1.4	3.8
	40.0	10.0	29.2	6.0	17.5	3.8	11.0	3.0	8.8	2.0	5.8	1.5	4.4
	50.0	10.9	32.6	6.35	19.6	4.1	12.2	3.3	9.8	2.2	6.5	1.6	4.9
	60.0	11.7	35.8	7.0	21.5	4.4	13.4	3.5	10.7	2.3	7.2	1.7	5.4
04	20.0	9.5	27.2	5.7	16.3	3.6	10.2	2.9	8.2	1.9	5.4	1.4	4.1
	30.0	11.1	33.3	6.6	20.0	4.1	12.5	3.3	10.0	2.2	6.7	1.7	5.0
	40.0	12.3	38.5	7.4	23.1	4.6	14.4	3.7	11.5	2.5	7.7	1.9	5.8
	50.0	13.5	43.0	8.1	25.8	5.1	16.1	4.0	12.9	2.7	8.6	2.0	6.5
	60.0	14.5	47.1	8.7	28.3	5.4	17.7	4.4	14.1	2.9	9.4	2.2	7.1
05	20.0	11.1	33.5	6.7	20.1	4.2	12.6	3.3	10.1	2.2	6.7	1.7	5.0
	30.0	13.0	41.0	7.8	24.6	4.9	15.4	3.9	12.3	2.6	8.2	1.9	6.2
	40.0	14.6	47.4	8.7	28.4	5.5	17.8	4.4	14.2	2.9	9.5	2.2	7.1
	50.0	16.0	53.0	9.6	31.8	6.0	19.9	4.8	15.9	3.2	10.6	2.4	7.9
	60.0	17.2	58.0	10.3	34.8	6.5	21.8	5.2	17.4	3.4	11.6	2.6	8.7
06	20.0	12.6	39.5	7.6	23.7	4.7	14.8	3.8	11.9	2.5	7.9	1.9	5.9
	30.0	14.7	48.4	8.9	29.0	5.6	18.1	4.4	14.5	3.0	9.7	2.2	7.3
	40.0	16.7	55.9	10.0	33.5	6.3	21.0	5.0	16.8	3.3	11.2	2.5	8.4
	50.0	18.3	62.5	11.0	37.5	6.9	23.4	5.5	18.7	3.7	12.5	2.8	9.4
	60.0	19.8	68.4	11.9	41.1	7.4	25.7	5.9	20.5	4.0	13.7	3.0	10.3
08	20.0	15.4	50.6	9.2	30.4	5.8	19.0	4.6	15.2	3.1	10.1	2.3	7.6
	30.0	18.2	62.0	10.9	37.2	6.8	23.2	5.5	18.6	3.6	12.4	2.7	9.3
	40.0	20.6	71.6	12.4	42.9	7.7	26.8	6.2	21.5	4.1	14.3	3.1	10.7
	50.0	22.7	80.0	13.6	48.0	8.5	30.0	6.8	24.0	4.5	16.0	3.4	12.0
	60.0	24.6	87.6	14.8	52.6	9.2	32.9	7.4	26.3	4.9	17.5	3.7	13.1
10	30.0	21.2	73.7	12.7	44.2	7.9	27.7	6.3	22.1	4.2	14.7	3.2	11.1
	40.0	24.0	85.1	14.4	51.1	9.0	31.9	7.2	25.5	4.8	17.0	3.6	12.8
	50.0	26.5	95.2	15.9	57.1	9.9	35.7	8.0	28.6	5.3	19.0	4.0	14.3
	60.0	26.8	104.3	17.3	62.6	10.8	39.1	8.6	31.3	5.8	20.9	4.3	15.6

Tip Size	Boom Pressure (PSI)	Speed Range (MPH)											
		3 GPA		5 GPA		8 GPA		10 GPA		15 GPA		20 GPA	
12.5	30.0	24.2	86.0	14.5	51.6	9.1	32.2	7.3	25.8	4.8	17.2	3.6	12.9
	40.0	27.5	99.3	16.5	59.6	10.3	37.2	8.3	29.8	5.5	19.9	4.1	14.9
	50.0	30.5	111.0	18.3	66.6	11.4	41.6	9.1	33.3	6.1	22.2	4.6	16.7
	60.0	33.1	121.6	19.9	73.0	12.4	45.6	9.9	36.5	6.6	24.3	5.0	18.2
15	30.0	26.7	96.0	16.0	57.6	10.0	36.0	8.0	28.8	5.3	19.2	4.0	14.4
	40.0	30.4	110.9	18.3	66.5	11.4	41.6	9.1	33.3	3.1	22.2	4.6	16.6
	50.0	33.7	124.0	20.2	74.4	12.6	46.5	10.1	37.2	6.7	24.8	5.1	18.6
	60.0	36.7	135.8	22.0	81.5	13.8	50.9	11.0	40.7	7.3	27.2	5.5	20.4
20	30.0	30.3	110.4	18.2	66.2	11.4	41.4	9.1	33.1	6.1	22.1	4.5	16.6
	40.0	34.6	127.5	20.8	76.5	13.0	47.8	10.4	38.2	6.9	25.5	5.2	19.1
	50.0	38.4	142.5	23.0	85.5	14.4	53.4	11.5	42.8	7.7	28.5	5.8	21.4
	60	41.8	156.1	25.1	93.7	15.7	58.5	12.5	46.8	8.4	31.2	6.3	23.4

TABLE 4. Speed Table for Standard (Straight) Style Nozzle Bodies (Metric)

Tip Size	Boom Pressure (kPa)	Speed Range (km/h)											
		30 L/ha		50 L/ha		75 L/ha		100 L/ha		150 L/ha		175 L/ha	
015	140	8.1	16.0	4.9	9.6	3.2	6.4	2.4	6.7	1.6	3.2	1.4	2.7
	200	8.9	19.1	5.3	11.5	3.6	7.7	2.7	5.7	1.8	3.8	1.5	3.3
	275	9.7	22.4	5.8	13.5	3.9	9.0	2.9	6.7	1.9	4.5	1.7	3.8
	350	10.4	25.3	6.3	15.2	4.2	10.1	3.1	7.6	2.1	5.1	1.8	4.3
	400	10.9	27.0	6.5	16.2	4.3	10.8	3.3	8.1	2.2	5.4	1.9	4.6
02	140	9.3	20.8	5.6	12.5	3.7	8.3	2.8	6.2	1.9	4.2	1.6	3.6
	200	10.3	24.9	6.2	14.9	4.1	10.0	3.1	7.5	2.1	5.0	1.8	4.3
	275	11.4	29.2	6.8	17.5	4.6	11.7	3.4	8.8	2.3	5.8	2.0	5.0
	350	12.3	32.9	7.4	19.7	4.9	13.2	3.7	9.9	2.5	6.6	2.1	5.6
	400	12.9	35.2	7.7	21.1	5.2	14.1	3.9	10.6	2.6	7.0	2.2	6.0
025	140	10.7	26.3	6.4	15.8	4.3	10.5	3.2	7.9	2.1	5.3	1.8	4.5
	200	12.0	31.5	7.2	18.9	4.8	12.6	3.6	9.4	2.4	6.3	2.1	5.4
	275	13.3	36	8.0	22.2	5.3	14.8	4.0	11.1	2.7	7.4	2.3	6.3
	250	14.5	41.7	8.7	25.0	5.8	16.7	4.4	12.5	2.9	8.3	2.5	7.1
	400	15.2	44.5	9.1	26.7	6.1	17.8	4.6	13.4	3.0	8.9	2.6	7.6
03	140	11.9	31.3	7.1	18.8	4.8	12.5	3.6	9.4	2.4	6.3	2.0	5.4
	200	13.4	37.4	8.1	22.4	5.4	15.0	4.0	11.2	2.7	7.5	2.3	6.4
	275	15.1	43.8	9.0	26.3	6.0	17.5	4.5	13.2	3.0	8.8	2.6	7.5
	350	16.5	49.5	9.9	29.7	6.6	19.8	4.0	14.8	3.3	9.9	2.8	8.5
	400	17.3	52.9	10.4	31.7	6.9	21.2	5.2	15.9	3.5	10.6	3.0	9.1
04	140	14.4	41.2	8.6	24.7	5.8	16.5	4.3	12.4	2.9	8.2	2.5	7.1
	200	16.4	49.3	9.8	29.6	6.6	19.7	4.9	14.8	3.3	9.9	2.8	8.4
	275	18.5	57.8	11.1	34.7	7.4	23.1	5.6	17.3	3.7	11.6	3.2	9.9
	350	20.4	65.2	12.2	39.1	8.2	26.1	6.1	19.6	4.1	13.0	3.5	11.2
	400	21.5	69.7	12.9	41.8	8.6	27.9	6.5	20.9	4.3	13	3.7	11.9
05	140	16.8	50.8	10.1	30.5	6.7	20.3	5.0	15.2	3.4	10.2	2	8.7
	200	19.3	60.7	11.6	36.4	7.7	24.3	5.8	18.2	3.9	12.1	3.3	10.4
	275	21.9	71.1	13.1	42.7	8.8	28.5	6.6	21.3	4.4	14.2	3.8	12.2
	350	24.2	80.3	14.5	48.2	9.7	32.1	7.2	24.1	4.8	16.1	4.1	13.8
	400	25.5	85.8	15.3	51.5	10.2	34.3	7.7	25.7	5.1	17.2	4.4	14.7

Tip Size	Boom Pressure (kPa)	Speed Range (km/h)											
		30 L/ha		50 L/ha		75 L/ha		100 L/ha		150 L/ha		175 L/ha	
06	140	19.1	59.9	11.4	35.9	7.6	24.0	5.7	18.0	3.8	12.0	3.3	10.3
	200	22.0	71.5	13.2	42.9	8.8	28.6	6.6	21.5	4.4	14.3	3.8	12.3
	275	25.1	83.9	15.0	50.3	10.0	33.6	7.5	25.2	5.0	16.8	4.3	14.4
	350	27.8	94.6	16.7	56.8	11.1	37.9	8.3	28.4	5.6	18.9	4.8	16.2
	400	29.4	101.2	17.6	60.7	11.8	40.5	8.8	30.4	5.9	20.2	5.0	17.4
08	140	23.3	76.7	14.0	46.0	9.3	30.7	7.0	23.0	4.7	15.3	4.0	13.1
	200	27.0	91.6	16.2	55.0	10.8	36.7	8.1	27.5	5.4	18.3	4.6	15.7
	275	31.0	107.4	18.6	64.5	12.4	43.0	9.3	32.2	6.2	21.5	5.3	18.4
	350	34.4	121.2	20.6	72.7	13.8	48.5	10.3	36.4	6.9	24.2	5.9	20.8
	400	36.5	129.6	21.9	77.7	14.6	51.9	10.9	38.9	7.3	25.9	6.3	22.2
10	200	31.3	109.0	18.8	65.4	12.5	43.6	9.4	32.7	6.3	21.8	5.4	18.7
	275	36.1	127.8	21.6	76.7	14.4	51.2	10.8	38.4	7.2	25.6	6.2	21.9
	350	40.1	144.2	24.1	86.5	16.1	57.7	12.0	43.3	8.0	28.8	5.9	24.7
	400	42.6	154.2	25.6	92.5	17.1	61.7	12.8	46.3	8.5	30.8	7.3	26.4
12.5	200	35.9	127.1	21.5	76.3	14.4	50.9	10.8	38.1	7.2	25.4	6.2	21.8
	275	41.4	149.1	24.8	89.5	16.6	59.7	12.4	44.7	8.3	29.8	7.1	25.6
	350	46.1	168.2	27.7	100.9	18.5	67.3	13.8	50.5	9.2	33.6	7.9	28.8
	400	49.0	179.8	29.4	107.9	19.6	72.0	14.7	53.9	9.8	36.0	8.4	30.8
15	200	39.6	142.0	23.8	85.2	15.8	56.8	11.9	42.6	7.9	28.4	6.8	24.3
	275	45.7	166.5	27.4	99.9	18.3	66.6	13.7	50.0	9.1	33.3	7.8	28.6
	350	51.1	197.9	30.6	112.7	20.4	75.2	15.3	56.4	10.2	37.6	8.8	32.2
	400	54.3	200.8	32.6	120.5	21.7	80.4	16.3	60.2	10.9	40.2	9.3	34.4
20	200	44.9	163.2	26.9	97.9	18.0	65.3	13.5	49.0	9.0	32.6	7.7	28.0
	275	51.9	191.4	31.2	114.8	20.8	76.6	15.6	57.4	10.4	38.3	8.9	32.8
	350	58.1	215.9	24.8	129.6	32.2	86.4	17.4	64.8	11.6	43.2	10.0	37.0
	400	61.8	230.8	37.1	138.5	24.7	92.4	18.5	69.2	12.4	46.2	10.6	39.6

B**SECTION WIDTHS**

Use the following formulas to help calculate the section widths.

Calculate the section width with the formula:

$$T \times S = SW$$

Where T = the number of Tips in each section, S = the Spacing between tips, and SW = the Section Width.

FOR EXAMPLE:

7 tips in a section with spacing of 20 inches [50.8 cm] would yield:

$$\begin{aligned} & 7 \times 20 = 140 \\ & \text{or a Section Width of 140 inches [356 cm]. Enter 140 [356] as the width for this section.} \end{aligned} \quad (\text{EQ 1})$$

TARGET RATE CALIBRATION

The following information must be known in order to determine which spray nozzles to use with the sprayer:

- Nominal Application Pressure _____ PSI [kpa]
- Target Application Rate _____ GPA [lit/ha]
- Target Speed _____ MPH [km/h]
- Nozzle Spacing _____ inches [cm]

From this information, calculate the volume per minute per nozzle as follows:

$$NVPM = \frac{\text{Rate} \times \text{Speed} \times NS}{5,940[60,000]}$$

NVPM = Nozzle Volume per Minute (Gal/Min [L/Min]), Rate = Target Application Rate, Speed = Target Speed of Application, and NS = Nozzle Spacing.

FOR EXAMPLE:

Application Pressure = 30 PSI, Target Application Rate = 20 GPA, Target Speed = 5.2 MPH, and Nozzle Spacing = 20 inches

$$NVPM = \frac{20 \times 5.2 \times 20}{5,940} = 0.35$$

Using the calculated nozzle volume per minute of 0.35 at an application pressure of 30, select a boom nozzle which comes closest to providing the desired output.

PRODUCT CALIBRATION SETTINGS

RESPONSE SENSITIVITY

The response sensitivity controls how sensitive the system is to changes in pressure, flow, and speed. Decrease if the system pressure and rate oscillate slightly. Increase sensitivity if control is unresponsive. Avoid setting response rate and sensitivity above 70. The default value is 50.

DEADBAND

The deadband value is the allowable difference between the target rate and the actual application rate. The values range from 1 to 9, where 1 equals a 1% difference and 9 equals 9% difference.

PRESSURE CONTROL SETTINGS

RESPONSE RATE

The response rate controls how fast the system adjusts pressure and rate output. Decrease response rate if system pressure and rate oscillate greatly. Increase if control is unresponsive. Avoid setting the response rate and sensitivity above 70. The default value is 35.

AIM COMMAND FLEX™ NOZZLE CONTROL VALVE MAINTENANCE

TABLE 1. Maintenance Schedule

Inspection	Frequency	Procedure
Walk-Around Inspection of System Cables and Components	Weekly/as needed	<ol style="list-style-type: none"> 1. With the system power on, ensure all AIM Command FLEX™ NCV LEDs are flashing. If not, check the cable connections to the NCVs and the fuses in the fuse block located near the boom on the chassis cable harness. 2. Verify the boom cables are securely fastened to the boom and are not hanging below the lower boom tube. 3. Inspect each NCV for damage and proper installation on the nozzle bodies. 4. Verify that the AIM Command FLEX™ CANbus terminators (located on the boom cables on each boom tip) are present and securely tied to the boom cables.
System Rinse	Daily after use	<ol style="list-style-type: none"> 1. Ensure the main product tank is cleaned and filled with at least 100 gallons of fresh water or that the pump is drawing fresh water from the vehicle rinse tank. 2. Park the sprayer in a safe location to unfold the booms and spray. 3. Ensure the AIM Command FLEX™ product control mode is set to Auto. 4. Enter a target pressure of 40-60 psi and an application rate of 10-20 GPA. 5. Set the test speed to 6 MPH. 6. Enable the sprayer product pump. 7. Turn on all section switches and the master spray switch. 8. Continue to spray water out of the booms until all chemical is flushed from the system or at least 30 seconds. 9. Turn off the Master Spray Switch.

Inspection	Frequency	Procedure
System Rinse (for sprayers equipped with Air Blow Out systems)	Daily after use	<ol style="list-style-type: none"> 1. Perform a system rinse. 2. Set the AIM Command FLEX™ system to Manual mode. 3. Set the pump PWM to zero and Nozzle PWM to 50-75%. 4. Follow the vehicle manufacturer’s normal procedure for the Air Blow-Out function.
Injection Pump Rinse	Daily after use/ when switching chemicals	<ol style="list-style-type: none"> 1. Fill the chemical tank with water or another rinse agent, or use the pump tank inlet valve to select a separate rinse tank source (if present). 2. In AIM Command FLEX™ Manual mode, set a pump and nozzle PWM of approximately 50%. Set the injection pump rate to around 30-50 oz/acre. 3. With the injection pump set to ON, enter a self test speed. 4. Verify you are in a good location to spray the chemical from the injection pump and carrier lines. 5. Turn on the product pump, and turn on at least one boom section and the master spray switch. The injection pump should begin to draw rinse fluid into the pump and pump it into the carrier line. Continue spraying for approximately 30 - 60 seconds or until all of the chemical has been flushed from the system. 6. Turn Off the master switch and product pump. Verify the valve positions are set for the next application.
Walk-Around Inspection of System Cables and Components	Weekly/as needed	<ol style="list-style-type: none"> 1. With the system power on, ensure all AIM Command FLEX™ NCV LEDs are flashing. If not, check the cable connections to the NCVs and the fuses in the fuse block located near the boom on the chassis cable harness. 2. Verify the boom cables are securely fastened to the boom and are not hanging below the lower boom tube. 3. Inspect each NCV for damage and proper installation on the nozzle bodies. 4. Verify that the AIM Command FLEX™ CANbus terminators (located on the boom cables on each boom tip) are present and securely tied to the boom cables.
NCV Seal Replacement	After 500 hours or as needed. Inspect both before and after spray season.	<ol style="list-style-type: none"> 1. Turn off the AIM Command FLEX™ system and product pump. 2. Bleed any remaining pressure from the boom system. 3. Perform the Nozzle Control Valve maintenance procedure(page 86).

FIGURE 1. Seal Replacement Kits and Valve Body Assembly

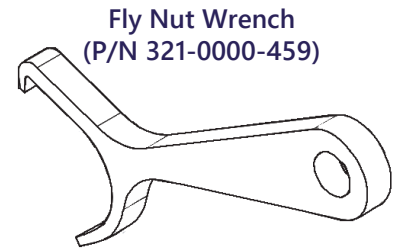
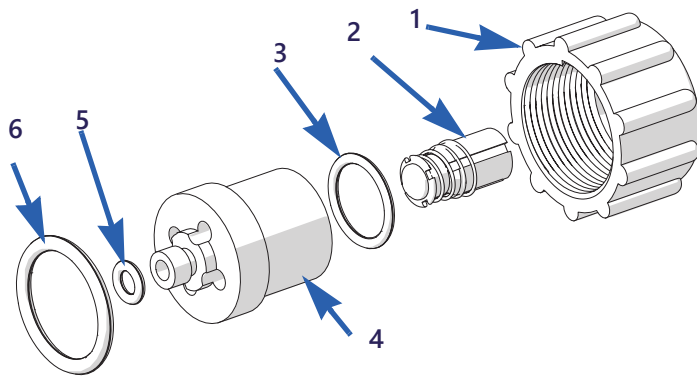

TABLE 2. Nozzle Control Valve Seal Replacement Kit Components

NCV Type	Manufacturer Part Number	Number on Figure 1	NCV Replacement Component	NCV Component Replacement Part Number
Hypro/Arag	063-0173-673	1	Fly Nut	117-1005-213
		2	Plunger Assembly	N/A
		3	O-Ring	N/A
		4	Stainless Valve Body	107-1005-003
		5	Outlet Seal	219-1005-001M
		6	O-Ring	219-1005-115M
		2, 3, 5, 6	Replacement Seal Kit - Quantity of 100	117-1005-211
		1, 2, 3, 5, 6	Single NCV Seal Replacement Kit - Quantity of 1	117-1005-051
	063-0173-810	1	Fly Nut	117-1005-214
		2	Plunger Assembly	N/A
		3	O-Ring	N/A
		4	Stainless Valve Body	107-1005-003
		5	Outlet Seal	219-1005-002M
		6	O-Ring	219-1005-115M
		2, 3, 5, 6	Replacement Seal Kit	117-1005-211
1, 2, 3, 5, 6		Single NCV Seal Replacement Kit - Quantity of 1	117-1005-051	

NCV Type	Manufacturer Part Number	Number on Figure 1	NCV Replacement Component	NCV Component Replacement Part Number
TeeJet	063-0173-672	1	Fly Nut	117-1005-213
		2	Plunger Assembly	N/A
		3	O-Ring	N/A
		4	Stainless Valve Body	107-1005-001
		5	Outlet Seal	219-1005-001M
		6	O-Ring	219-1005-115M
		2, 3, 5, 6	Replacement Seal Kit	117-1005-210
		1, 2, 3, 5, 6	Single NCV Seal Replacement Kit - Quantity of 1	117-1005-050
	063-0173-815	1	Fly Nut	117-1005-213
		2	Plunger Assembly	N/A
		3	O-Ring	N/A
		4	Stainless Valve Body	107-1005-001
		5	Outlet Seal	219-1005-001M
		6	O-Ring	219-1005-115M
2, 3, 5, 6		Replacement Seal Kit	117-1005-210	
1, 2, 3, 5, 6		Single NCV Seal Replacement Kit - Quantity of 1	117-1005-050	

NCV Type	Manufacturer Part Number	Number on Figure 1	NCV Replacement Component	NCV Component Replacement Part Number
Wilger	063-0173-674	1	Fly Nut	117-1005-215
		2	Plunger Assembly	N/A
		3	O-Ring	N/A
		4	Stainless Valve Body	107-1005-002
		5	Outlet Seal	219-1005-002M
		6	O-Ring	219-1005-116M
		2, 3, 5, 6	Replacement Seal Kit	117-1005-212
		1, 2, 3, 5, 6	Single NCV Seal Replacement Kit - Quantity of 1	117-1005-052
	063-0173-809	1	Fly Nut	117-1005-215
		2	Plunger Assembly	N/A
		3	O-Ring	N/A
		4	Stainless Valve Body	107-1005-002
		5	Outlet Seal	219-1005-002M
		6	O-Ring	219-1005-116M
		2, 3, 5, 6	Replacement Seal Kit	117-1005-212
		1, 2, 3, 5, 6	Single NCV Seal Replacement Kit - Quantity of 1	117-1005-052

NOZZLE CONTROL VALVE MAINTENANCE PROCEDURE

AIM Command FLEX™ nozzle control valves are designed to provide maintenance free operation with proper equipment maintenance as recommended by the equipment or chemical manufacturer. However, the seals may become worn or swollen due to chemical compounds, chemical formulations, or high operating pressures. This may cause accelerated wear to the sealing surfaces. The following nozzle control valve maintenance procedures should be performed on the nozzle control system or on individual nozzles if leaks are observed at a specific spray tip.

FIGURE 2. Nozzle Control Valve Maintenance Detail

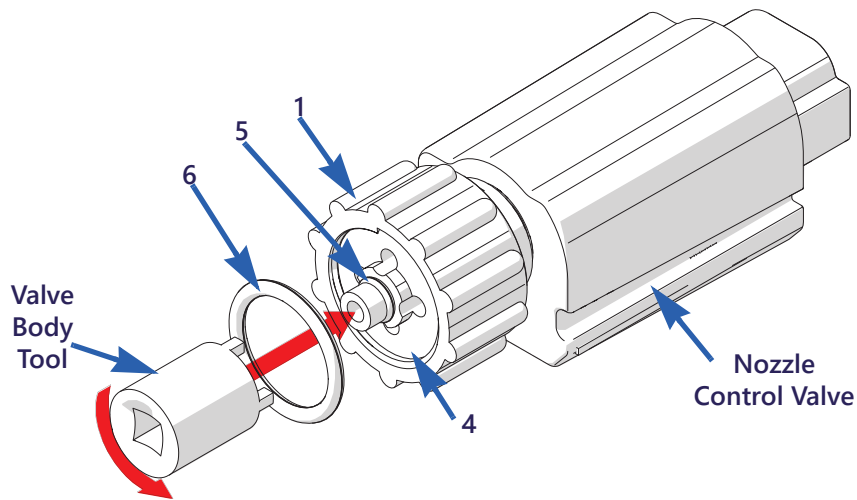

1. Loosen the fly nut (item 1) and remove the AIM Command FLEX™ nozzle control valve from the nozzle body.
2. Inspect the large o-ring (item 6) on the face of the valve body (item 4). Replace if necessary.
3. Inspect the small o-ring (item 5) on the tip of the valve body. Replace if necessary.
4. Using a valve body removal tool (P/N 321-0000-457), loosen and remove the valve body (item 4) from the AIM Command FLEX™ nozzle control valve.

FIGURE 3. Nozzle Control Valve Exploded View

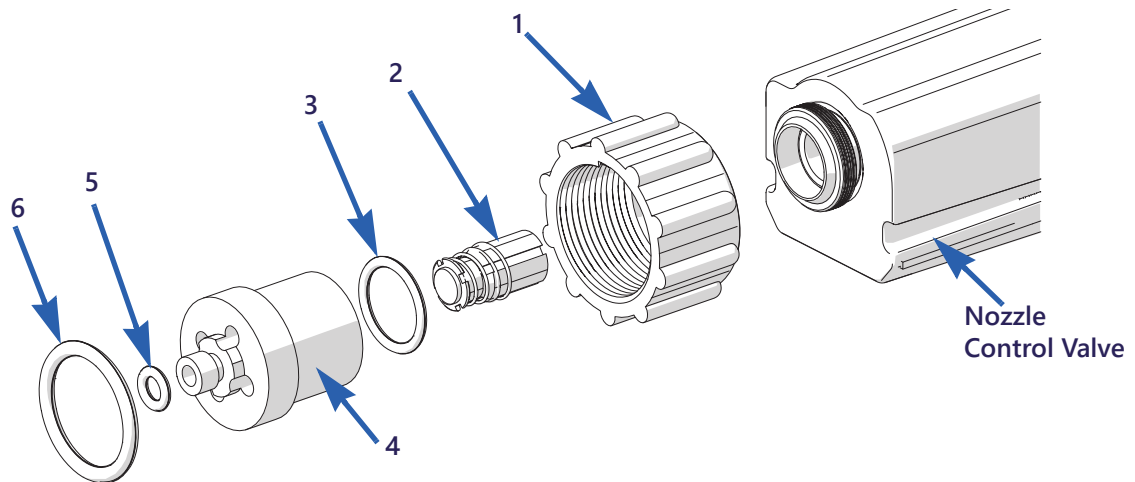

5. Inspect the o-ring (item 3) on the inside of the valve body. Replace if necessary.
6. Clean and inspect the plunger assembly (item 2). Replace the plunger assembly if the rubber seal is worn or damaged. Refer to Figure 4 on page 88 for reference to plunger seal condition.
7. Inspect fly nut (item 1). Replace if worn or damaged.

FIGURE 4. Plunger Inspection Detail

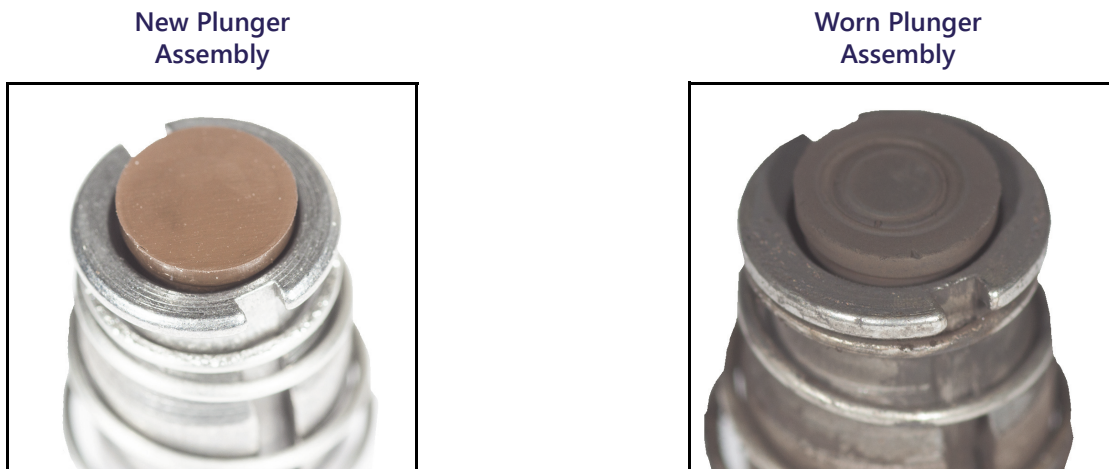

NOTE: Seal color may vary.

AIM COMMAND FLEX™ NOZZLE CONTROL VALVE ASSEMBLY PROCEDURE

To reassemble a nozzle control valve after inspection and maintenance:

FIGURE 5. Nozzle Control Valve Assembly

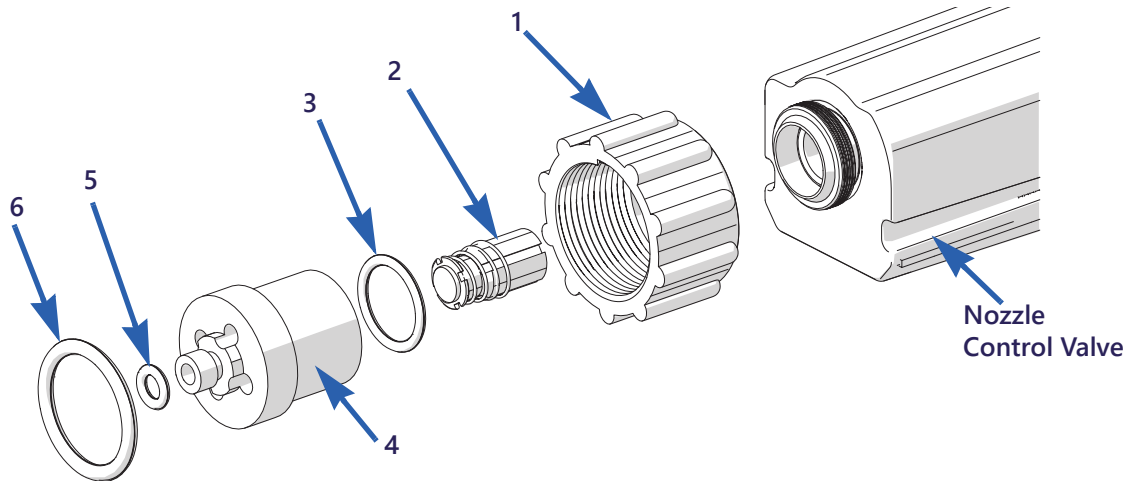

1. Replace fly nut (item 1) over valve body (item 4).
2. Replace o-ring (item 3) inside valve body.
3. Place plunger assembly (item 2) into nozzle control valve cavity.
4. Thread the valve body onto the nozzle control valve and finger tighten.
5. Using a valve body removal tool (P/N 321-0000-457), turn valve body 1/4 to 1/3 turn to secure to the valve body.
6. Verify small o-ring (item 5) is seated into groove on valve body tip.
7. Place large o-ring (item 6) onto valve body face.
8. Thread fly nut onto nozzle body on equipment spray boom.
9. Hand tighten the fly nut to the nozzle body or use the fly nut wrench if necessary. Do not over tighten.

-
10. Prior to filling the tank with chemical or starting a field application, refer to the *Testing for Leaks* section on page 89 to test the AIM Command FLEX™ system.

SYSTEM TESTING

TESTING FOR LEAKS

1. Fill the applicator tank with clean water.
2. Toggle the implement master switch to the on position.
3. Select the pump softkey to activate the product pump.
4. Toggle one section switch to the on position.
5. Inspect the AIM Command FLEX™ nozzle control valves for leaks around the fly nut.
6. If leaks are observed:
 - a. Toggle the section and master switches to the off position.
 - b. Use the AIM Command FLEX™ fly nut wrench to carefully tighten the fly nut until leaking ceases.
 - c. If leaking continues after tightening the fly nut more than half a turn, perform the procedures outlined in the *AIM Command FLEX™ Nozzle Control Valve Maintenance* section on page 81 to inspect the nozzle control valve, o-rings, and plunger assembly.
 - d. Repeat this procedure to verify leak has stopped. Contact a local Case IH dealer for additional assistance if leaks persist.
7. Repeat this process to check nozzle control valves on each section of the equipment.

FLOW METER MAINTENANCE

NOTE: Remove system pressure and chemical from the hoses and all other system lines prior to disassembling the flow meter, fittings, or hoses.

1. Remove flow meter from the equipment and flush with clean water to remove any chemicals.
2. Remove flange bolts or clamp from the flow meter.
3. Remove the turbine hub and turbine from inside flow meter.
4. Clean turbine and turbine hub of metal filings or any other foreign material, such as wettable powders. Confirm that the turbine blades are not worn. While holding the turbine hub in your hand, spin turbine. The turbine should spin freely with very little drag inside the hub.
5. If transducer assembly is replaced or if turbine stud is adjusted or replaced, verify the turbine fit before reassembling. Hold turbine hub with turbine on transducer. Spin turbine by blowing on it. Tighten turbine stud until turbine stalls. Loosen turbine stud 1/3 turn. The turbine should spin freely.
6. Re-assemble flow meter.
7. Using a low pressure (approximately 5 PSI [34.5 kPa]) jet of air, verify the turbine spins freely. If there is drag, loosen hex stud on the bottom of turbine hub 1/16 turn until the turbine spins freely.
8. If the turbine spins freely and cables have been checked per *Troubleshooting Flow Meter Cables* section on page 56, but flow meter still is not metering properly, replace flow meter transducer.

RECALIBRATING THE FLOW METER

To calibrate the flow meter:



1. Fill the applicator tank with clean water.
2. Open the UT Menu and select the AIM Command FLEX™ menu button.
3. From the home screen, select the Tools Menu softkey along the right side of the display.
4. Select the System Settings tab along the top of the display and select the Product Control Settings button.
5. Enter a value of 10 [38] for the meter cal.
6. Select the Home softkey along the right side of the display and then select the Tally Registers softkey.
7. Enter a value of zero for the total volume value.
8. Toggle the master switch and all boom sections to the off positions.
9. Remove a section hose and place it into a calibrated five gallon [19 liter] container.
10. Toggle the master switch and the boom switch corresponding to the hose that was placed in the container.
11. Pump exactly ten gallons [38 liters] of water to fill the container twice.
12. Check the total volume registered on the UT tally registers prompt. The reading displayed is the new meter cal value. This value should be within ± 3% of the calibration number stamped on the tag of the flow meter.
13. Repeat this procedure several times to confirm accuracy. Always “zero out” the total volume display before retesting.

NOTE: For increased precision, set meter cal to 100 [378] and pump 100 gallons (378 liters) of water.

14. To verify the flow meter calibration, the fill applicator tank with a predetermined amount of measured liquid (i.e. 250 gallons [946.4 L]).

NOTE: Do not rely on graduation marks molded into the applicator tank.

15. Empty the applicator tank under normal operating conditions.
If the total volume displayed is different from the predetermined amount of measured liquid by more than ± 3%, complete the following calculation:

$$CMC = \frac{MC \times V_M}{V_A}$$

Where CMC = the Corrected Meter Cal, MC = the Meter Cal used to apply the known volume, and VM = the Volume measured by the UT tally registers prompt, and VA = the predetermined volume applied.

FOR EXAMPLE:

The UT displays a Total Volume of 260 [984] when a Meter Cal of 720 [190] was used to apply a measured volume of 250 gallons [946 liters]. Therefore:

English	Metric
$CMC = \frac{720 \times 260}{250} = 749$	$CMC = \frac{[190] \times [984]}{[946]} = [198]$

the Corrected Meter Cal is 749 [198]

16. Return to the Product Control Settings prompt and enter a value of 749 [198] for the meter cal.

POWER AND PRODUCT CONTROLLER II ECU HARNESS MAINTENANCE

1. Disconnect the Product Controller II ECU harness connector and inspect for signs of moisture or corrosion.
2. If moisture or corrosion is detected, use Deoxit D5, brushes, and compressed air to clean and dry the connector.
3. When clean, apply a coating of Corrosion X HD to the connector mating surfaces and contacts.
4. Reattach the connectors.

BOOM HARNESS CONNECTOR MAINTENANCE

Prior to connecting the AIM Command FLEX™ boom cable to the AIM Command FLEX™ Nozzle Control Valves (NCV), perform the following steps to all 6-pin NCV connectors and 19-pin circular connectors between the boom cables and Product Controller II ECU cable connections to ensure high quality connections:

1. Verify the NCV connectors and the accompanying boom cable connectors are free of moisture, contamination, or oxidation. Oxidation will appear as a dry, white coating on the contacts. If any connectors show signs of moisture, contamination, or oxidation, perform Step 2 - Step 6. If this is a new installation, skip to Step 7. All components listed below can be ordered in the AIM Command FLEX™ NCV Connection Maintenance Kit (P/N 117-0171-692).
2. Spray the connection with a deoxidizing agent (DeoxIT D5 is recommended (P/N 222-4001-006)).

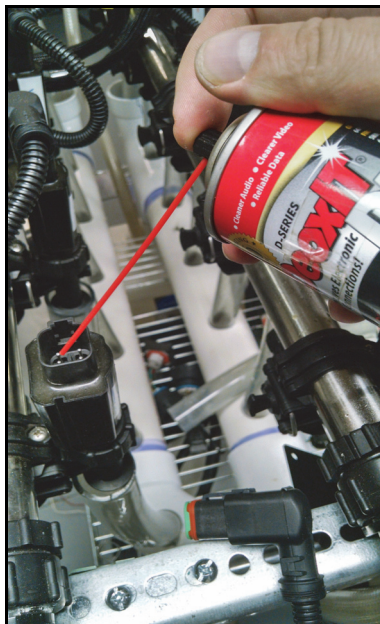

3. Clean contacts with a small wire brush (P/N 321-0000-477).

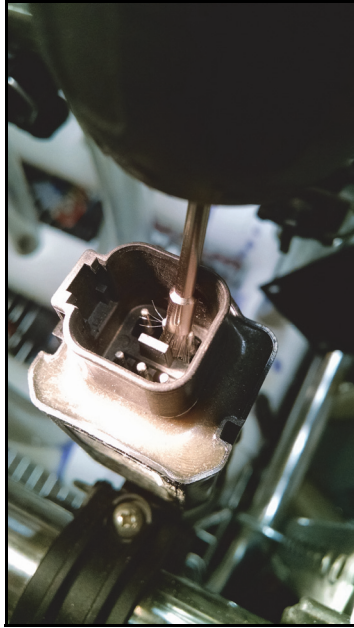

4. Spray the contacts again with the deoxidizing agent. This will rinse out debris.
5. Remove all residue of deoxidizing agent from the connection. Not removing deoxidizing agent can damage the connector seal.
6. Dry out the connection with dry, compressed air. Dust Off Electronics Duster (P/N 222-4001-007) is recommended however, if unavailable, alternate compressed air sources can be used. If using compressed air from a large volume air compressor, be sure the lines are free of moisture.



7. If not already applied, apply a single short burst of corrosion inhibitor (Corrosion X HD (Raven P/N 222-0000-020 or available from <http://www.corrosionx.com/corrosionx-heavy-duty.html>)) into the NCV connection. Be sure the corrosion inhibitor has coated the NCV contacts and recessed portions of the connector.

NOTE: To determine if corrosion inhibitor has been applied, inspect for a thick liquid in the bottom of the connector (as shown in the Corrosion Inhibitor Applied image below).

FIGURE 1. Applying Corrosion Inhibitor

NCV Connector

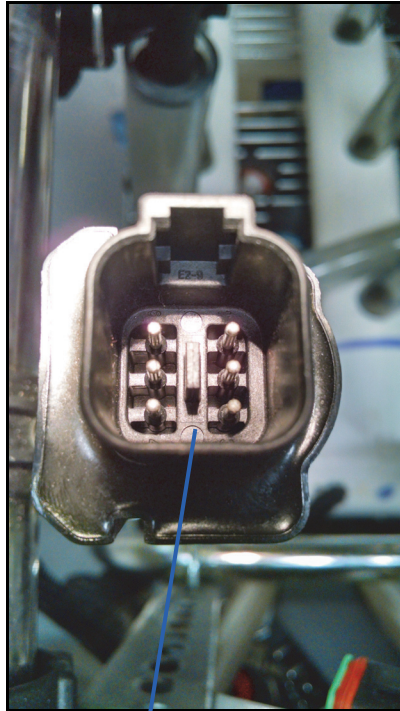

Spray in Void
Between Pins

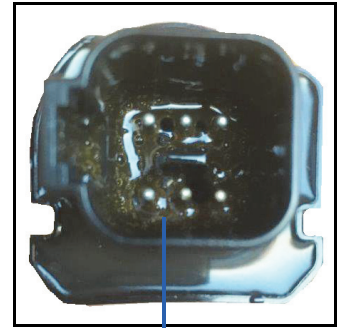

Corrosion Inhibitor Applied

AIM COMMAND FLEX™ STORAGE AND START-UP CHECKLIST

This section provides procedures to maintain the AIM Command FLEX™ system. There are checks to perform before storing the equipment and also starting the equipment after long periods without use.

PRESEASON CLEANING AND FLUSHING

The AIM Command FLEX™ system requires a few steps in addition to your sprayer manufacturer's recommended preseason maintenance and inspection. To prepare the AIM Command FLEX™ system:

1. Remove and clean all of the product strainers.
2. Replace the strainers after they are clean and dry.
3. Fill the product tank with at least 200 gallons of clean water.
4. If the boom tubes have a flush valve at the end, open the flush valves and flush the boom tubes with 100 gallons of clean water.
5. Close the flush valves.
6. Remove all of the spray tips or turn the nozzle bodies to an open position (no tips) and flush the booms with the remaining water.

START-UP INSPECTION

Follow the inspection instructions in the vehicle specific installation manual. Perform these steps with the key on without the engine running.

1. Verify that 80 mesh or finer screens are installed upstream of the AIM Command FLEX™ nozzle control valves.
2. Flush the boom plumbing and tank before running liquid through the AIM Command FLEX™ nozzle control valves.
3. Ensure the AIM Command FLEX™ nozzle control valves are recognized by the AIM Command FLEX™ Product Controller II ECU. If not, repeat the Calibration Wizard. If the AIM Command FLEX™ Product Controller II ECU is not present on the UT screen, check the vehicle specific AIM Command FLEX™ installation manual to verify the AIM Command FLEX™ Product Controller II ECU cable harness and vehicle power cable harnesses are installed correctly.
4. Ensure that the boom and flow meter information have been properly entered into the equipment settings.
5. Ensure the pressure sensor(s) are calibrated properly.
 - a. Verify the correct sensor value is entered.
 - b. Relieve trapped pressure in the boom. Ensure the pressure sensor reads 0 PSI and calibrate.
6. Ensure the Min and Max PWM have been entered to match the specific value of the vehicle installed. Leaving min at 0 will cause the valve to respond slowly while increasing pressure. If max is left at 100 PWM, the valve may reduce pressure slowly.
7. Verify the boom configuration has been imported into the machine settings. Failure to do this will cause the boom sections to not be recognized in a job. Virtual sections should show up in boom settings. If properly

completed, the ISO icon at the top right of the screen will be green. AIM Command FLEX™ nozzle control valves must be properly indexed for this to work.

8. Inspect the status of the overlap control unlock. Temporary unlock is usually active upon start-up but a permanent unlock purchase is required to ensure proper overlap control operation.
9. Ensure the alarm indicator is green. Red indicates a serious error condition that will prevent the system from spraying. Yellow alarm indicates a warning that requires investigation but will not prevent spraying. Clear all conditions as necessary.
10. Enter a test speed in the UT mode. The boom section switches on the vehicle should respond with the corresponding boom section icons in the UT window. No triangle indicates that the boom is off. an empty triangle indicates the boom is active but is being controlled by Accuboom. A triangle that is filled in blue indicates the boom is spraying. The nozzle control valves should click of operating properly. Expect a pump pressure error because the pump is not running.

NOTE: With water in the tank this step can be performed with the engine running. Do not run the pump for an extended period of time with no liquid in the tank because this may damage the seals.

11. Start a job. Ensure that all necessary widgets are available to the operator to allow proper machine operation. Make a copy for the complete widget setup for the operator to modify.
12. In job view mode, enter a test speed. Verify that the section control is off. The boom section switches should respond to the corresponding boom sections in the UT window. No triangle means the boom is off. An empty triangle indicates the boom is active but is being controlled by Accuboom. A triangle filled in blue means the boom should be spraying. Expect a pump pressure error since the pump is not running. if the booms do not respond correctly, delete and import the boom settings.

NOTE: With water in the tank this step can be performed with the engine running. Do not run the pump for an extended period of time with no liquid in the tank because this may damage the seals.

13. After all systems are functions properly, will the tank with water and complete the functional inspection.

FUNCTIONAL INSPECTION

Refer to the following sections for assistance with validating that the AIM Command FLEX™ nozzle control system has been installed properly:

NOZZLE CONTROL VALVE FUNCTION

To verify that the AIM Command FLEX™ nozzle control system is functioning properly after installation:

1. Flush the main product tank and boom plumbing with clean water, and verify the tank contains at least 100 gallons [379 L] of clean water.
2. Park the equipment in an area with enough space to unfold the booms and allows for visual inspection of the spray pattern from a moderate distance (e.g. 20 ft [6.1 m]).
3. Set the AIM Command FLEX™ nozzle control system to manual mode, and set both the pump PWM and nozzle PWM to 50%. Refer to the ± *Bump* section on page 39 for assistance with adjusting the PWM percent values in the manual control mode.
4. Toggle all section switches and the master switch.

	<p style="text-align: center;">WARNING</p> <p>Equipment will begin spraying. Avoid inhaling spray particulate and avoid direct contact with any agricultural chemicals. Seek immediate medical attention if symptoms of illness occur during, or soon after, use of agricultural chemicals, products, or equipment.</p>
---	--

-
5. While maintaining a safe distance away from any spray drift, visually check that all nozzle control valves are pulsing with a uniform pattern. Adjacent nozzle control valves should alternate pulsing. If adjacent spray tips are pulsing at the same time, refer to Chapter 8, *Troubleshooting*, for additional assistance.
 6. On the UT, set nozzle PWM to 0% to close the nozzle control valves.
 7. Visually check that none of the nozzles are spraying or dripping. Refer to *Testing for Leaks* section on page 89 for additional assistance and troubleshooting if leaks are observed.

TURN COMPENSATION FEATURE INSPECTION

To verify the Turn Compensation feature is enabled and operating as anticipated:

NOTE: Complete the procedure outlined in the *Nozzle Control Valve Function* section on page 98 to validate the nozzle control valve function prior to performing the following procedure.

If the AIM Command FLEX™ system came installed on the equipment from the equipment manufacturer, or if a sparge pressure transducer is installed with the AIM Command FLEX™ control system, check the transducer specifications and refer to the “Advanced Transducer Calibration” on page 31 for additional information.

1. Move the implement to an open area where the equipment may be turned.
2. Verify that the turn compensation feature is enabled.
3. Set the system to automatic mode and toggle the section and master switches to the on positions. Refer to Chapter 5, *Operation*, for additional assistance with operation of the nozzle control system.
4. While driving at a speed between 5 and 10 mph [8 and 16 km/h] and maintaining a safe working distance, observe the inner-most and outer-most spray tips while the implement is turning sharply.

NOTE: The nozzle PWM percent value may also be used to monitor the operation of nozzle control valves across the spray boom. Refer to Chapter 7, *AIM Command FLEX™ Nozzle Control Valve Diagnostics*, for additional assistance with on-screen nozzle control valve diagnostics.

5. While turning, the nozzle control valves toward the outside of the corner should begin to output a higher flow rate (higher PWM percent), while valves toward the inside of the corner should begin to output a reduced flow rate (lower PWM percent) or may shut off. The difference between inner and outer flow rates will vary depending on machine speed, turn rate, and implement width.
6. If the operator is able to observe a difference in the spray pulsing, a difference in high, average, and low values on the NCV performance indicator, or the on-screen PWM percent located in the nozzle diagnostics screens, the turn compensation feature is working correctly. If there is no difference between the PWM percent values across the implement width, recalibrate the turn compensation feature and repeat this test.

OVERLAP CONTROL ADJUSTMENT

Refer to the sprayer specific manual for information on adjusting overlap control.

WINTERIZING AND STORING THE SYSTEM

Refer to the sprayer manufacturer winterizing and storing procedure for information on preparing equipment for storage. Do not rely on blow-out systems to remove all the water and/or chemicals from the system. If water, or other fluids, are trapped in the AIM Command FLEX™ system components could freeze and cause severe damage. AIM Command FLEX™ nozzle control system components are compatible with most types of automotive, RV, and marine antifreeze solutions.

AIM COMMAND FLEX™ FLOWCHART

This section provides a flowchart of the AIM Command FLEX™ screens and may be useful for navigating through the UT. The flowcharts start on the next page.

FIGURE 1. AIM Command FLEX™ Screen Navigation (Tools Menu Softkey)

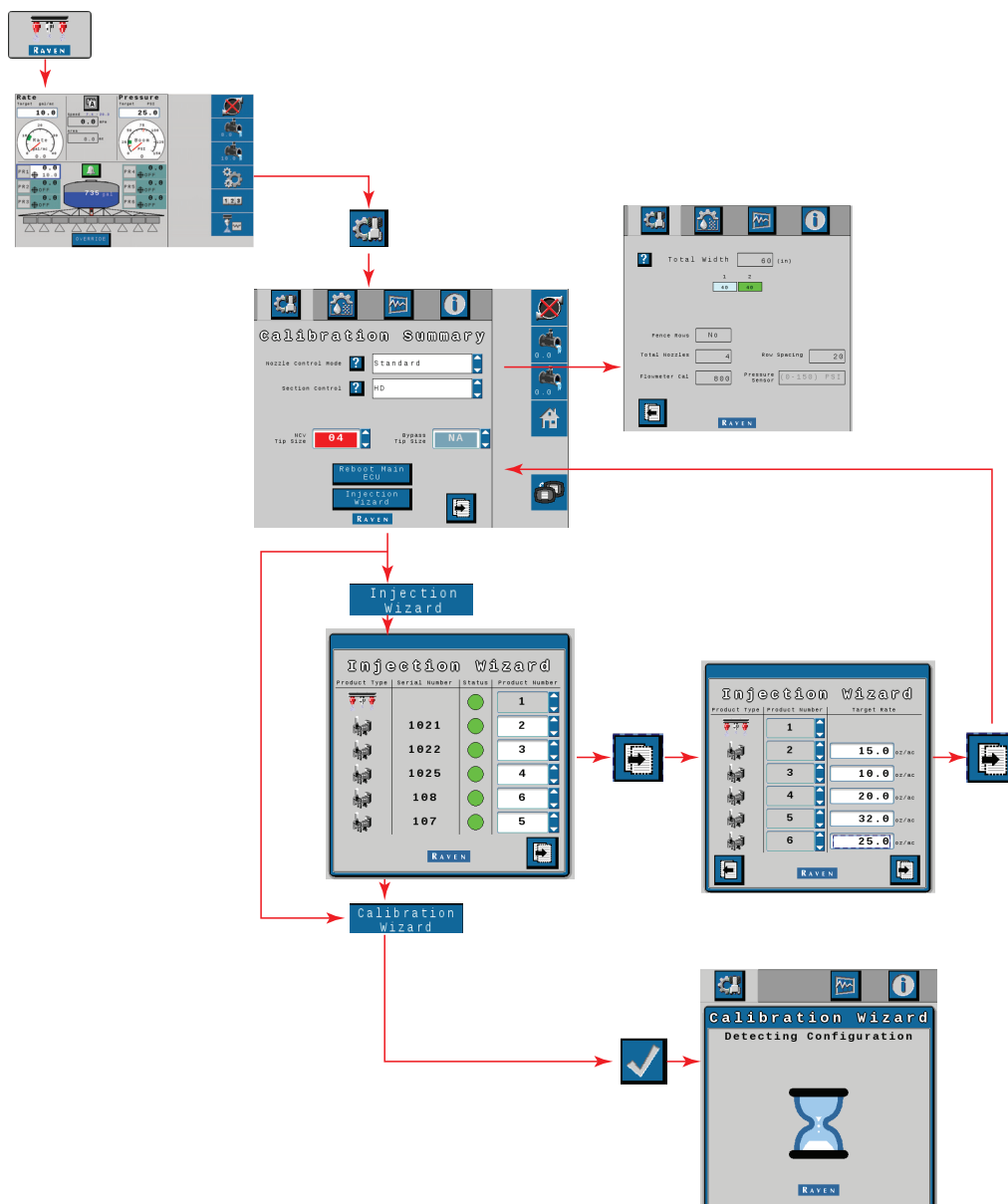

FIGURE 2. AIM Command FLEX™ Screen Navigation (Tools Menu Softkey Continued)

Press OK on any of the settings screens to return to the System Settings screen.

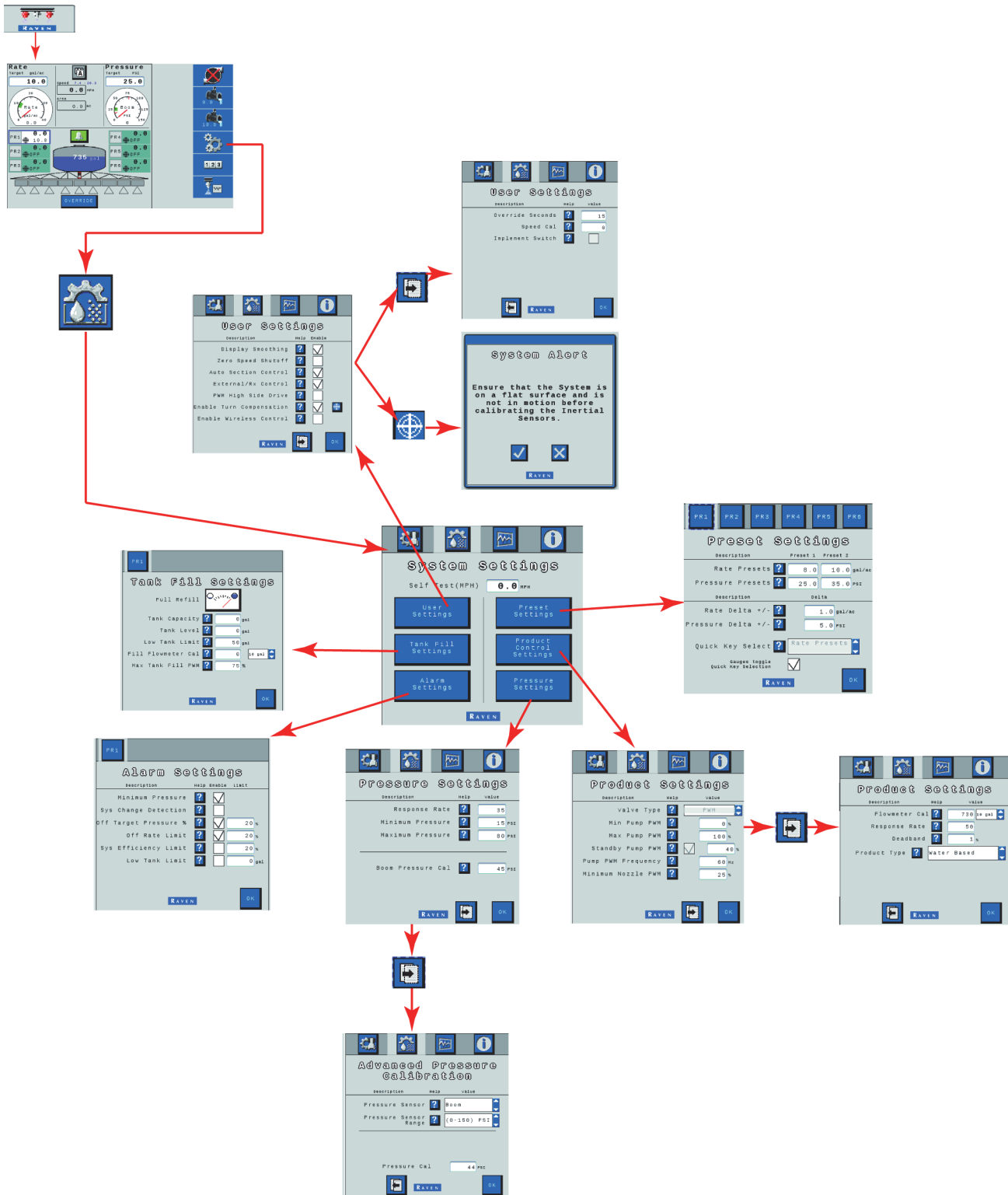

FIGURE 3. AIM Command FLEX™ Screen Navigation (Tools Menu Softkey Continued)

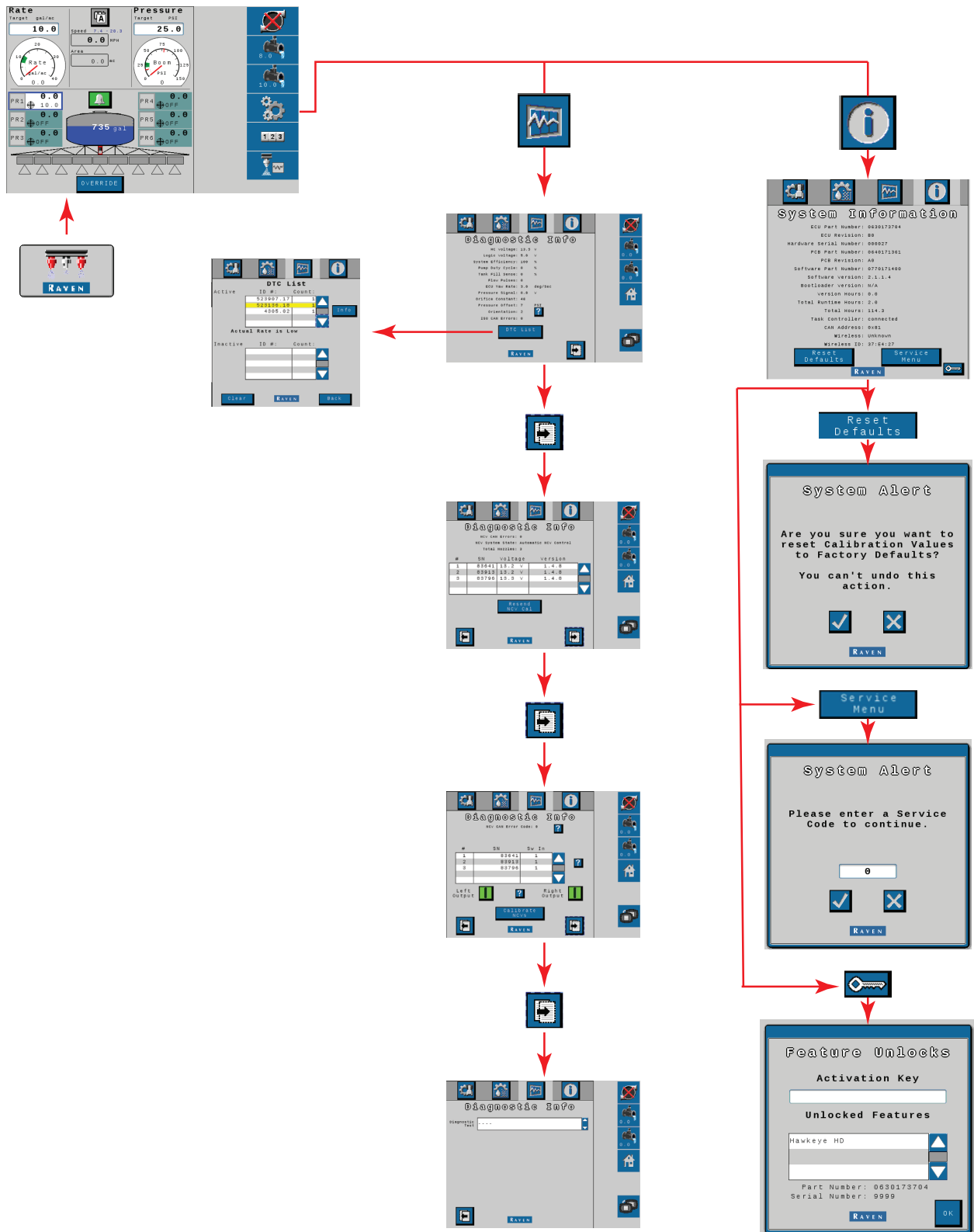

FIGURE 4. AIM Command FLEX™ Screen Navigation (Tally Registers and Diagnostics Menu Softkeys)

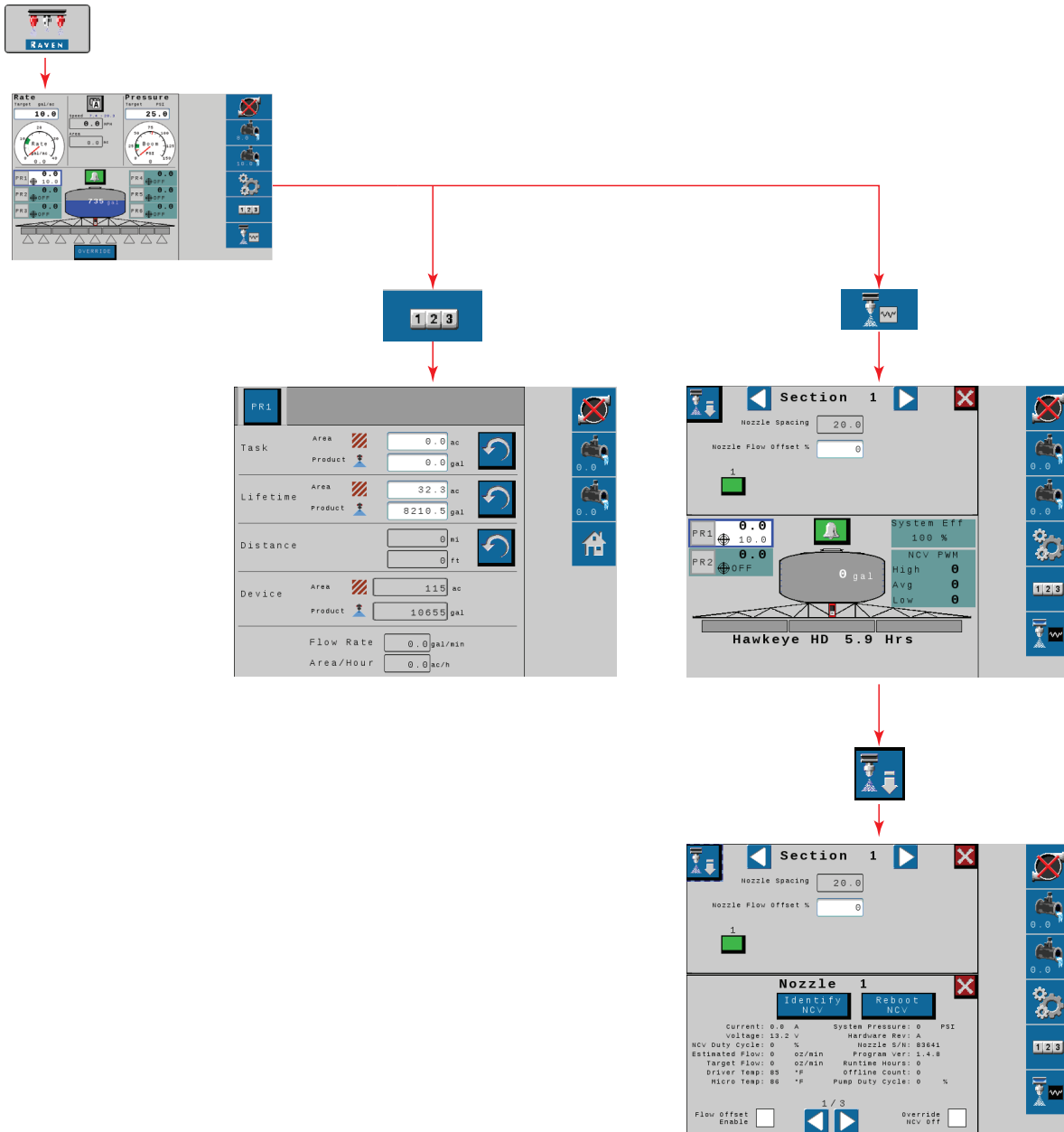

FIGURE 5. AIM Command FLEX™ Injection Screen Navigation (Diagnostics Information and Calibration)

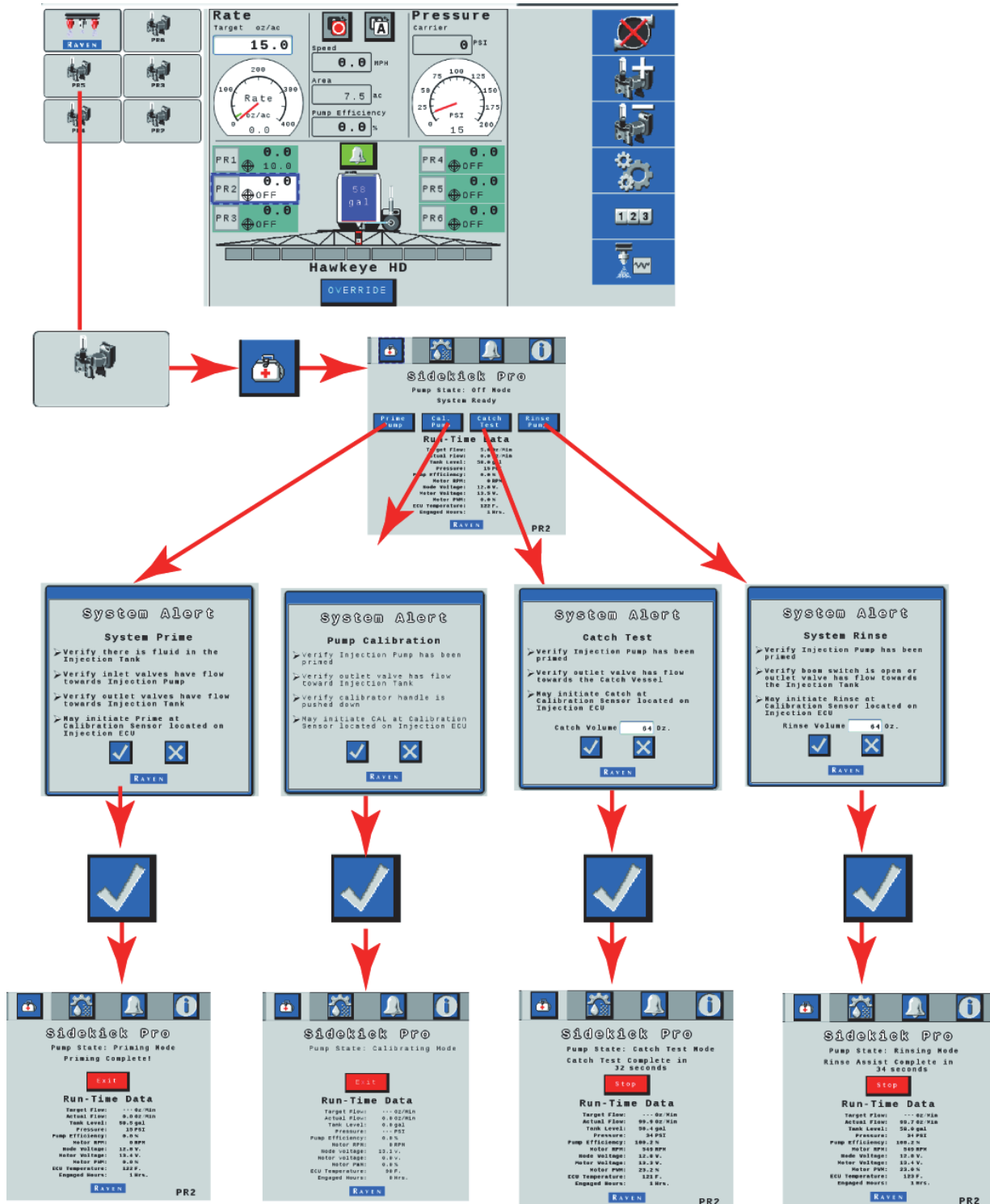
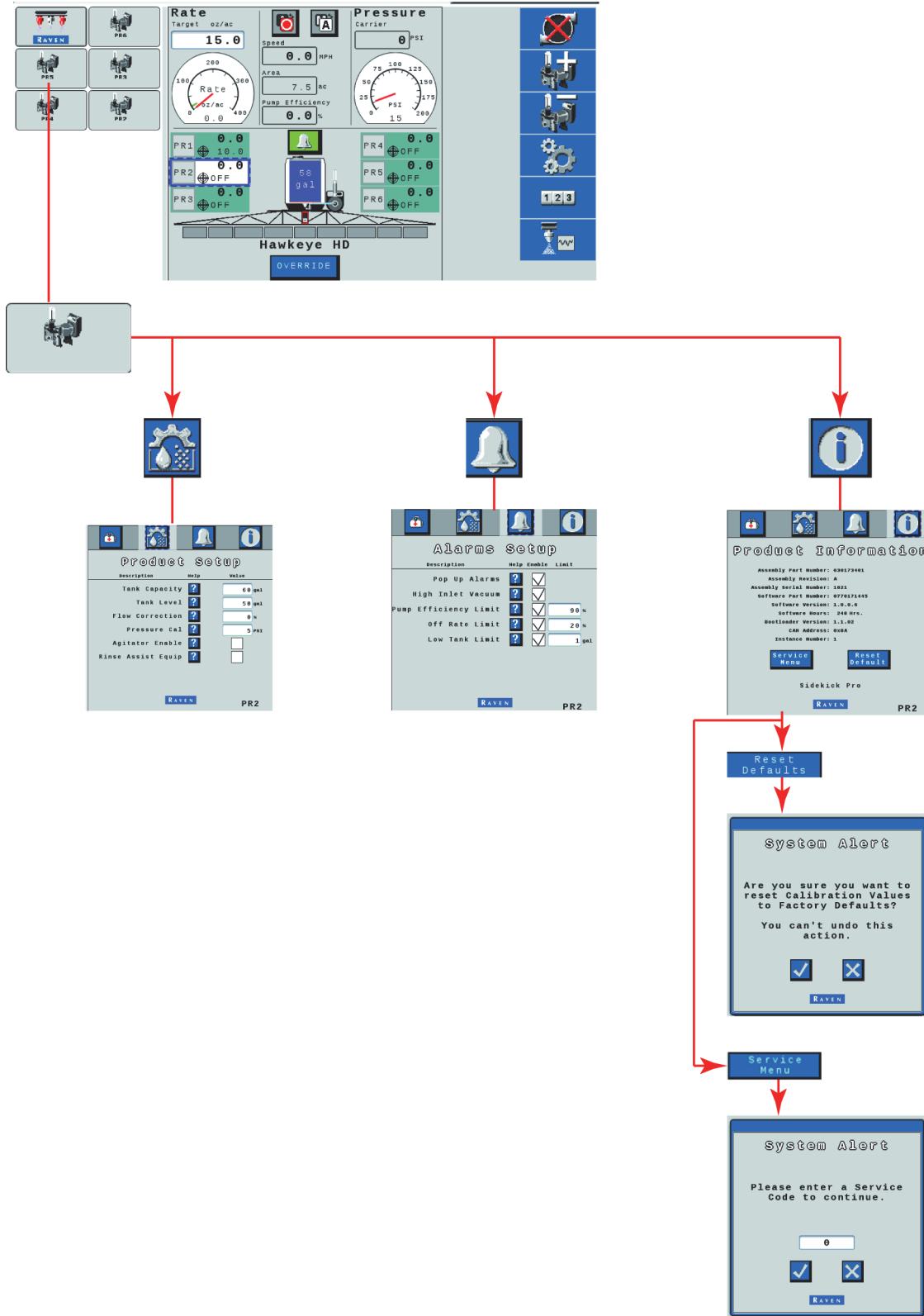

FIGURE 6. AIM Command FLEX™ Injection Screen Navigation (Product Setup, Alarms, and System Information)



REMOTE OPERATION

Refer to the Section Control Remote 2.0 Quick Guide (P/N 016-0171-685) shipped in the section remote box for Section Control Remote configuration and operation instructions.

DIAGNOSTICS APPLICATION OPERATION

This section provides information on the Remote Diagnostics Application (available on the Raven App store). AIM Command FLEX™ allows the user to control the system and perform diagnostics through a personal mobile device such as a tablet or smart phone. The user can turn on and off boom sections, turn the pump on or off, and view real-time system information for troubleshooting or demonstration purposes without having to leave the cab. A Bluetooth low energy (BLE) compatible device is required.

The Remote Diagnostics Application is available for download and use on any Android or iOS Bluetooth low energy compatible device.

To use the diagnostics application:

- System speed must be zero.
- The application must be connected to PC II.
- The Enable Wireless Control check box must be checked in the PC II User Settings.
- Master Switch and Boom Section switches must be on.

DIAGNOSTIC APPLICATION BEST PRACTICES

- Verify the system speed is zero on the PCII home screen and there are no alarms for the PCII or NCV bus.
- Verify Bluetooth functionality is turned on for the mobile device.
- Go to PCII System Information Page and check the Enable Wireless Control checkbox.
- Turn on all boom switches and master switch using the machine switches.

IMPORTANT: Do not attempt to connect to devices yet.

OUTSIDE OF THE MACHINE CAB

- Exit the cab and walk to the back of the boom until you can see PCII.
- Enter the mobile diagnostics app and wait for the device with the matching Wireless ID to be detected. Select that device.
- When prompted, enter the Hardware Serial Number as the passcode. This should only require entry the first time the mobile device is paired to PCII.
- Turn the product pump On and Off using the pump icon on the app.

- Turn On and Off the spray sections and NCVs as needed using the ON and OFF buttons, Left/Right Indexing Arrows or the sections to be displayed on the application.
 - Sections and NCVs will turn on as the boom is mapped for conventional or bypass spray control.
 - To take control of the spray sections, the OFF and ON buttons may need to be toggled.
- Turn off sections and pump on the application when back in the cab.
- Disconnect the application or move the vehicle. This will uncheck the Enable Wireless Control checkbox in the User Settings screen.
 - Any time the Enable Wireless Control box is unchecked, or the boom and master switches are in the wrong position, Control Disabled will display on the app.

MOBILE APPLICATION SCREENS

The section provides an overview of the mobile application.

DIAGNOSTICS

The Diagnostics screen displays the following information:

FIGURE 1. Diagnostics Screen

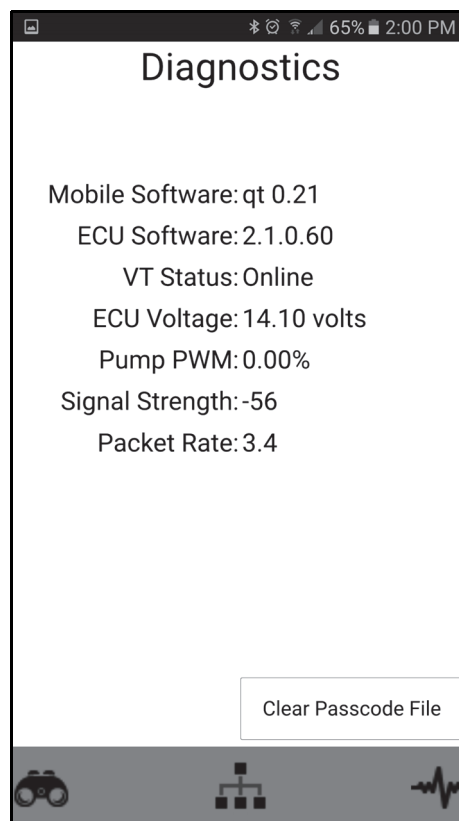

- Mobile Software - Application software version
- Product Controller II ECU Software - Connected Product Controller II ECU software version
- UT Status - UT Connection Status
- Product Controller II ECU Voltage - Connected Product Controller II ECU voltage
- Pump PWM - Pump PWM percentage

- Signal Strength - Wireless signal strength at the time of connection
- Packet Rate - Wireless data speed
- Clear Passcode File Button - Select this button to clear all passcodes entered into the mobile app. The passcode will need to be entered again next login.

FIGURE 2. Diagnostics Screen

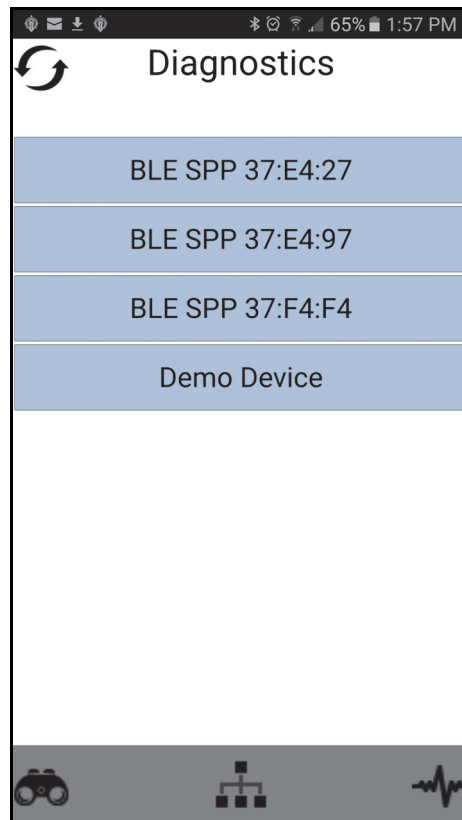

This list will show all of the supported Product Controller II ECU Wireless IDs the mobile device has detected.

Select the desired Product Controller II ECU Wireless ID (the wireless ID can be found on the System Information screen on the PC II CT) and enter the passcode. The passcode will display on the UT display. If the Product Controller II ECU Wireless ID has already been connected, no passcode is required and the application will automatically switch to the next page.

NOTE: Only one Product Controller II ECU can be connected at a time. The Product Controller II ECU wireless ID will not show up if it is connected to another mobile device.

NOTE: Selecting Demo Device will open the application in demo mode and not connect to a Product Controller II ECU. This mode is for exploring the mobile application.

CONTROL SCREEN

Section Status. The Control screen displays the status for each section configured. When active, a section displays a countdown indicating how long the section will be on before the system shuts the section back off.

NOTE: When the timer expires, all sections must be toggled off before sections may be toggled on again.

Control Disabled. Indicates the application is not controlling the sections. Possible issues could be the master switch is off, wireless control is disabled, or actual speed detected.

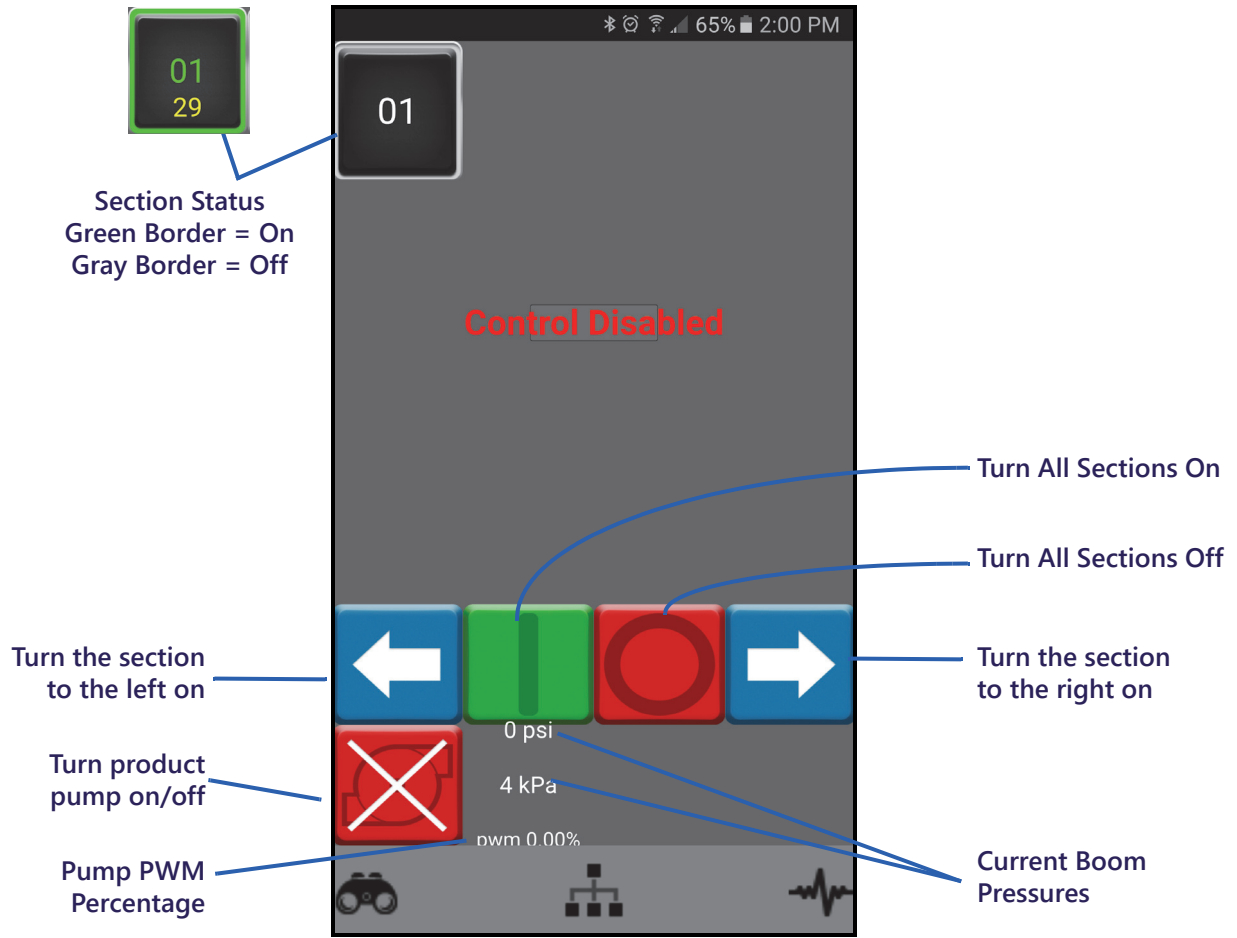

FIGURE 3. Control Screen



NOTE: When the timer expires, all sections must be turned off before they can be turned back on again.

TABLE 1. Mobile App Icons

Icon	Function
	Turn section on or off. There is an icon for turning the section to the right or left of.
	Turn all sections on.
	Turn all sections off.

Icon	Function
	Turn product pump off.
	Section Status. Green border indicates on. Gray border indicates off.

A

Application Mode 41
Application Speed Guide 74
Area Applied 41
Automatic Nozzle Indexing 12

B

Boom Harness Connector Maintenance 93

C

Calibration Values
 Section Widths 69, 79, 101
Calibration Wizard 11
Care and Use 10
Controller Diagnostics Information 32
Current Vehicle Speed and Application Speed
 Range Display 42

D

Direct Injection 8
DTC Alarm Status Indicator 44

E

Edit Mode vi
Equipment Settings Tab 18

F

Fence Row Display 20
Fence Row Setup 13
Flow Meter Maintenance 89
Flow Meter Maintenance and Adjustment
 Procedure 81, 97, 107

G

General Troubleshooting 65

H

Hawkeye Lower Home Screen 43
Hawkeye Upper Home Screen 40
Home Screen 37
 Application Speed 42
 Area Covered 44
 Remote Master (Switch) Status 43
 Section Status Display 44
 Volume Applied 44

I

Important Safety Information 1
 Electrical Safety 2
Individual Nozzle Control 9
Injection Pump Efficiency 42
Injection Wizard 15, 19
Injection Wizard and Calibration 14
Introduction
 Unit Definitions and Conversions vi
 Unit of Measure Conversions vi
 Unit of Measure Definitions vi

M

Max Tank Fill PWM 25
Meter and Cal Units 13

N

Nozzle Control Mode 18
Nozzle Control Valve Function 13
Nozzle Control Valve Maintenance 81, 86
Nozzle Control Valve Status 53
Nozzle Spacing Display 20
Nozzle Technical Specifications 54

O

Operation Checklist 37
Operation Modes 7

P

Power and ECU Harness Maintenance 93
Pressure Control Settings 80
Pressure Gauge 42
Pressure Nozzle Control 9
Product Calibration Settings 80
Product Control Home Screen 37

R

Rate Gauge 41
Reboot Main ECU 19
Recalibrating the Flow Meter 90

S

Section Control Mode 18
Section Status Display 44
Section Widths 79
Storage and Start-Up Checklist 97
System Information 34
System Settings - Alarm 25

System Settings - Presets 26
System Settings - Pressure 29
System Settings - Product Control 28
System Settings - Tank Fill 24
System Settings - User Settings 21
System Testing 89

T

Tally Registers

Area per Hour Display 48
Distance 48
Field Area and Volume 48
Total Area and Volume 48
Volume per Minute Display 48

Target Calibration Rate 79

Target Pressure 42

Target Rate 41

Testing Flow Meter Cables 56

Testing for Leaks 89

Testing NCV Cable Connections 54

Tip Selection and Application Speed Guide 72

Tip Size Option 19

Toggle Nozzle Count Display 20

Tools Menu Overview 17

Turn Compensation 9, 14

U

Updates 10

Using Tally Registers 47

V

Virtual Sections 9

Volume Applied 44

W

Wheel Tracks 9

LIMITED WARRANTY

WHAT DOES THIS WARRANTY COVER?

This warranty covers all defects in workmanship or materials in your Raven Applied Technology Division product under normal use, maintenance, and service when used for intended purpose.

HOW LONG IS THE COVERAGE PERIOD?

Raven Applied Technology products are covered by this warranty for 12 months from the date of retail sale. In no case will the Limited Warranty period exceed 24 months from the date the product was issued by Raven Industries Applied Technology Division. This warranty coverage applies only to the original owner and is non-transferable.

HOW CAN I GET SERVICE?

Bring the defective part and proof of purchase to your Raven dealer. If the dealer approves the warranty claim, the dealer will process the claim and send it to Raven Industries for final approval. The freight cost to Raven Industries will be the customer's responsibility. The Return Materials Authorization (RMA) number must appear on the box and all documentation (including proof of purchase) must be included inside the box to be sent to Raven Industries.

WHAT WILL RAVEN INDUSTRIES DO?

Upon confirmation of the warranty claim, Raven Industries will (at our discretion) repair or replace the defective product and pay for the standard return freight, regardless of the inbound shipping method. Expedited freight is available at the customer's expense.

WHAT IS NOT COVERED BY THIS WARRANTY?

Raven Industries will not assume any expense or liability for repairs made outside our facilities without written consent. Raven Industries is not responsible for damage to any associated equipment or products and will not be liable for loss of profit, labor, or other damages. The obligation of this warranty is in lieu of all other warranties, expressed or implied, and no person or organization is authorized to assume any liability for Raven Industries.

Damages caused by normal wear and tear, misuse, abuse, neglect, accident, or improper installation and maintenance are not covered by this warranty.

EXTENDED WARRANTY

WHAT DOES THIS WARRANTY COVER?

This warranty covers all defects in workmanship or materials in your Raven Applied Technology Division product under normal use, maintenance, and service when used for intended purpose.

DO I NEED TO REGISTER MY PRODUCT TO QUALIFY FOR THE EXTENDED WARRANTY?

Yes. Products/systems must be registered within 30 days of retail sale to receive coverage under the Extended Warranty. If the component does not have a serial tag, the kit it came in must be registered instead.

WHERE CAN I REGISTER MY PRODUCT FOR THE EXTENDED WARRANTY?

To register, go online to www.ravenhelp.com and select Product Registration.

HOW LONG IS THE EXTENDED WARRANTY COVERAGE PERIOD?

Raven Applied Technology products that have been registered online are covered for an additional 12 months beyond the Limited Warranty for a total coverage period of 24 months from the date of retail sale. In no case will the Extended Warranty period exceed 36 months from the date the product was issued by Raven Industries Applied Technology division. This Extended Warranty coverage applies only to the original owner and is non-transferable.

HOW CAN I GET SERVICE?

Bring the defective part and proof of purchase to your Raven dealer. If the dealer approves the warranty claim, the dealer will process the claim and send it to Raven Industries for final approval. The freight cost to Raven Industries will be the customer's responsibility. The Return Materials Authorization (RMA) number must appear on the box and all documentation (including proof of purchase) must be included inside the box to be sent to Raven Industries. In addition, the words "Extended Warranty" must appear on the box and all documentation if the failure is between 12 and 24 months from the retail sale.

WHAT WILL RAVEN INDUSTRIES DO?

Upon confirmation of the product's registration for the Extended Warranty and the claim itself, Raven Industries will (at our discretion) repair or replace the defective product and pay for the standard return freight, regardless of the inbound shipping method. Expedited freight is available at the customer's expense.

WHAT IS NOT COVERED BY THE EXTENDED WARRANTY?

Raven Industries will not assume any expense or liability for repairs made outside our facilities without written consent. Raven Industries is not responsible for damage to any associated equipment or products and will not be liable for loss of profit, labor, or other damages. Cables, hoses, software enhancements, and remanufactured items are not covered by this Extended Warranty. The obligation of this warranty is in lieu of all other warranties, expressed or implied, and no person or organization is authorized to assume any liability for Raven Industries.

Damages caused by normal wear and tear, misuse, abuse, neglect, accident, or improper installation and maintenance are not covered by this warranty.