

**AccuFlow Vortex Installation Manual:  
John Deere 2510 H**

*P/N 016-0171-610 Rev. B 03/17 E29018*

## ***Disclaimer***

---

While every effort has been made to ensure the accuracy of this document, Raven Industries assumes no responsibility for omissions and errors. Nor is any liability assumed for damages resulting from the use of information contained herein.

Raven Industries shall not be responsible or liable for incidental or consequential damages or a loss of anticipated benefits or profits, work stoppage or loss, or impairment of data arising out of the use, or inability to use, this system or any of its components. Raven Industries shall not be held responsible for any modifications or repairs made outside our facilities, nor damages resulting from inadequate maintenance of this system.

As with all wireless and satellite signals, several factors may affect the availability and accuracy of wireless and satellite navigation and correction services (e.g. GPS, GNSS, SBAS, etc.). Therefore, Raven Industries cannot guarantee the accuracy, integrity, continuity, or availability of these services and cannot guarantee the ability to use Raven systems, or products used as components of systems, which rely upon the reception of these signals or availability of these services. Raven Industries accepts no responsibility for the use of any of these signals or services for other than the stated purpose.

---

|                  |  |           |
|------------------|--|-----------|
| <b>Chapter 1</b> | <b><i>Important Safety Information</i></b> .....           | <b>1</b>  |
|                  | Instructions for Wire Routing .....                        | 4         |
|                  | Instructions for Hose Routing .....                        | 5         |
| <b>Chapter 2</b> | <b><i>Introduction</i></b> .....                           | <b>7</b>  |
|                  | Introduction .....   | 7         |
|                  | Point of Reference .....                                   | 7         |
|                  | Required Tools and Supplies .....                          | 7         |
|                  | Kit Contents .....   | 7         |
|                  | JDB-PF11-005 Parts .....                                   | 8         |
|                  | JDB-PF11-151 Parts .....                                   | 13        |
|                  | JDB-PF11-161 Parts .....                                   | 16        |
|                  | Updates .....  | 18        |
| <b>Chapter 3</b> | <b><i>AccuFlow™ Vortex Cooler Assembly</i></b> .....       | <b>19</b> |
|                  | Assembly Overview .....                                    | 19        |
|                  | Inlet Manifold Assembly .....                              | 19        |
|                  | Leak Test .....  | 20        |
|                  | Vapor Port Assembly .....                                  | 21        |
| <b>Chapter 4</b> | <b><i>Mounting</i></b> .....                               | <b>23</b> |
|                  | Attaching Cooler to Mounting Brackets .....                | 23        |
|                  | 11 and 15 Row .....  | 24        |
|                  | 23 Row .....   | 25        |
| <b>Chapter 5</b> | <b><i>Section Valve and Impellicone Assembly</i></b> ..... | <b>27</b> |
|                  | Impellicone Assembly .....                                 | 27        |
|                  | Dual Impellicone Example .....                             | 29        |
| <b>Chapter 6</b> | <b><i>Hose &amp; Supply Line Installation</i></b> .....    | <b>31</b> |
|                  | Supply Line Installation .....                             | 31        |
|                  | Applicator Line Installation .....                         | 32        |
|                  | Vapor Line Installation .....                              | 34        |
|                  | Bleed Line Hose Routing .....                              | 35        |
|                  | Emergency Shut-off Rope Installation .....                 | 36        |
| <b>Chapter 7</b> | <b><i>Replacement Parts</i></b> .....                      | <b>37</b> |
|                  | Replacement Parts .....                                    | 37        |



---

# CHAPTER

# 1

# IMPORTANT SAFETY INFORMATION

---

## NOTICE

- Read this manual carefully and the operation and safety instructions included with the implement and/or controller.
  - Follow safety information presented within this manual and review operation with your dealer.
  - Contact your dealer for additional assistance or support with any portion of the installation or service of Raven equipment or to obtain replacement parts, manuals, or labels.
- Follow all safety labels affixed to components. Be sure to keep safety labels in good condition and replace any missing or damaged labels.
- Review procedures for safe handling and use of anhydrous ammonia (NH<sub>3</sub>) and properties of NH<sub>3</sub> with your NH<sub>3</sub> supplier. If you are not trained to handle, transfer, apply, transport, install, operate, or service NH<sub>3</sub> equipment, contact your dealer, NH<sub>3</sub> supplier, or the appropriate agricultural department for training information.
- NH<sub>3</sub> can be harmful to the environment if not used properly. Follow all local, state, and federal regulations regarding proper handling of NH<sub>3</sub>.
- Follow all label instructions for chemical mixing, handling, and NH<sub>3</sub> container disposal methods.
- When operating the machine:
  - Be alert and aware of surroundings.
  - Do not operate the device while under the influence of alcohol or illegal substances.
  - Ensure the device is disabled prior to starting maintenance work on the machine.
  - Follow all label instructions for chemical mixing, handling, and container disposal methods.
- Only NH<sub>3</sub> harness systems, control systems, and on/off valves approved by Raven Industries are recommended for use with this system. Raven shall not be liable for any damages and this warranty shall not cover defects from:
  - The use of a system with a harness not approved by Raven.
  - The use of a control system not approved by Raven.
  - The use of an on/off switch not approved by Raven.
  - The use of the system in a manner that is inconsistent with the instructions.
  - Unauthorized modification to the system or products used in the system.

## DANGER

- Anhydrous Ammonia (NH<sub>3</sub>) Under Pressure. NH<sub>3</sub> can cause severe burning, blindness, sickness, or death. Understand all safety instructions and warnings before operating or servicing equipment. Review safety requirements associated with NH<sub>3</sub> with your supplier.

- Seek immediate medical attention if symptoms of illness occur during, or shortly after, use of NH<sub>3</sub> products.
- In case of leak or accidental release of NH<sub>3</sub>, immediately evacuate the area, contact your local fire department, and identify sources of clean water on the unit.

## CAUTION

- Use caution when handling anhydrous ammonia (NH<sub>3</sub>) products. Always wear personal protective equipment (PPE) when working with anhydrous ammonia. Appropriate PPE includes, but is not limited to:
  - Indirect vent chemical splash goggles or indirect vent chemical splash goggles with full face shield.
  - Liquid proof gauntlet-style gloves impervious to NH<sub>3</sub>.
  - Long sleeved shirt and long pants or protective suit.
- Stand 'up wind' when working around NH<sub>3</sub> and related equipment. Never work on NH<sub>3</sub> equipment in confined spaces. Always keep NH<sub>3</sub> equipment away from buildings, livestock, and other people.
- Keep a full source of clean water (at least five gallons in addition to and separate from the water source on the nurse tank) readily available while working with NH<sub>3</sub>. In case of exposure, flush exposed skin or eyes immediately with large quantities of water for at least 15 minutes and seek immediate medical attention.
- Never uncouple an NH<sub>3</sub> applicator or intermediate towing vehicle without appropriate parking stands, wheel chocks, or other braking systems if a nurse tank wagon is attached.
- Always remove the system from NH<sub>3</sub> service before performing maintenance.
  - Thoroughly bleed all system lines and disconnect nurse tank hose before beginning service or maintenance.
  - Remove all NH<sub>3</sub> from the system before disassembling or servicing.
- Use extreme caution when opening a previously pressurized system.
  - Pressure gauges can fail, become plugged, or display incorrect pressure. Every section where NH<sub>3</sub> can be trapped should be treated as if it were pressurized.
- Before performing service or maintenance on the system, read and follow the instructions provided with the equipment to properly discharge NH<sub>3</sub>.

### INTRODUCTION

#### POINT OF REFERENCE

All references to left, right, front, or back are made assuming you are standing at the back of the implement looking toward the vehicle hitch.

#### REQUIRED TOOLS AND SUPPLIES

- Pipe wrenches (must accommodate 2" minimum pipe size)
- SAE and Metric combination wrenches
- SAE and Metric deep well sockets and socket wrench
- Lifting device rated at 350 lbs. [160 kg]

#### KIT CONTENTS

This sections contains tables that show images of the parts included in each kit shipped with the AccuFlow™ Vortex cooler. The images included in the tables are not to scale and are for reference purposes only.

JDB-PF11-005 PARTS

TABLE 1. Kit Parts

| Item Image  | Part Description                      | Part Number  | Quantity |
|---|---------------------------------------|--------------|----------|
|    | Strainer, Y Type, 2" W/ Magnets       | 063-0173-655 | 2        |
|    | Valve Assembly, 2", NH3, Vented Index | 063-0173-688 | 1        |
|   | Back Check Valve W/ Relief            | 063-0173-691 | 1        |
|  | Back Check Valve W/ Bleed Valve       | 063-0173-692 | 2        |
|  | Vortex Assembly, Dual Valve, No Pump  | 063-0173-714 | 1        |
|  | Weldment, Inlet Manifold, Reverse     | 116-0159-755 | 1        |
| No Image  | Hose, 12', 1/2", NH3                  | 214-0001-049 | 1        |
| No Image  | Sealant, Pipe Thread, 4 Oz Can        | 222-1001-088 | 1        |



TABLE 1. Kit Parts

| Item Image  | Part Description                      | Part Number  | Quantity |
|---|---------------------------------------|--------------|----------|
|    | Bolt, 5/16" - 18 UNC x 1" Hex         | 311-0052-080 | 2        |
|    | Nut, Flange, Lock, 5/16" - 18, Zinc   | 312-1001-169 | 2        |
| No Image  | Rope, Poly Braided, 1/4" D            | 321-0000-359 | 1        |
| No Image  | Teflon Tape                           | 332-0000-038 | 2        |
|    | Fitting, 1" NPT x 3/4" HB             | 333-0002-305 | 4        |
|  | Fitting, 90 Degree, 1" NPT, 3/8" HB   | 333-0002-306 | 2        |
|  | Fitting, Barb Tube, 1/4" NPT, 3/8" HB | 333-0002-904 | 1        |
|  | Coupling, 1/2" x 1/4"                 | 333-0002-905 | 1        |
|  | Fitting, Reducer, 1.5" x 1.25"        | 333-0003-096 | 1        |



TABLE 1. Kit Parts

| Item Image  | Part Description                    | Part Number  | Quantity |
|---|-------------------------------------|--------------|----------|
|    | Fitting, Reducer, 2" x 1.5"         | 333-0003-097 | 2        |
|    | Fitting, Tee, 3/8" Hose Barb        | 333-0004-037 | 1        |
|   | Fitting, Cross, 1" NPT, 150         | 333-0004-046 | 2        |
|  | Nipple, Pipe, 1" x 2", SCH 80       | 333-0008-500 | 2        |
|  | Nipple, 1-1/4" x Close              | 333-0008-499 | 1        |
|  | FTG, Pipe Nipple, SCH80, 2" x 3" LG | 333-0008-502 | 3        |

TABLE 1. Kit Parts

| Item Image  | Part Description                 | Part Number  | Quantity |
|---|----------------------------------|--------------|----------|
|    | FTG, 1.5" x Close Nipple, SCH 80 | 333-0008-491 | 3        |
|    | Fitting, Plug, 1" NPT            | 333-0009-065 | 2        |
|    | Bleed Valve                      | 334-0001-012 | 4        |
|  | Needle Valve, 1/4" NPT           | 334-0001-064 | 1        |
|  | Valve, Relief, 1/4" NPT          | 334-0002-005 | 3        |
|  | Clamp, Worm Drive, Hose 1/2"     | 435-3003-002 | 6        |

TABLE 1. Kit Parts

| Item Image  | Part Description              | Part Number  | Quantity |
|---|-------------------------------|--------------|----------|
|  | Clamp, Worm Drive, Hose, 3/4" | 435-3003-003 | 12       |
|  | Clamping U-bolt, 2-1/2"       | 435-3003-062 | 2        |

## JDB-PF11-151 PARTS

TABLE 2. Installation Hardware







| Item Image  | Part Description                          | Part Number  | Quantity |
|---|---|--------------|----------|
|    | Bracket, Mounting, Valve, HP AccuFlow     | 107-0171-931 | 1        |
|    | Bracket, Support, Inlet Manifold          | 107-0172-305 | 1        |
|   | Bracket, Inlet Extension                  | 107-0172-383 | 1        |
|    | Strap, AccuFlow Vortex                    | 107-0172-439 | 1        |
| No Image  | Hose Supply, 10', 1-1/2", NH3             | 214-0001-048 | 2        |
|   | Coupler, Breakaway, 1.50", NH3            | 333-0002-307 | 2        |
|  | U-Bolt, 6.06" W x 5.00" L x 3/8" - 16 UNC | 107-0171-916 | 1        |

TABLE 2. Installation Hardware

| Item Image  | Part Description                      | Part Number  | Quantity |
|---|---------------------------------------|--------------|----------|
|    | U-Bolt, 2510 S & C, Rectangular       | 107-0171-894 | 2        |
|    | Bolt, Hex, 3/8" - 16 UNC x 1.25" Long | 311-0054-081 | 4        |
|    | Bolt, Hex, M12 - 1.75" x 200 mm Long  | 311-0070-029 | 2        |
|    | Nut, Flange Lock, 3/8" - 16 UNC       | 312-1001-164 | 6        |
|  | Nut, Flange Lock, M12                 | 312-1001-177 | 6        |
|  | Fitting, 1-1/2" Swivel                | 333-0001-031 | 2        |
|  | Fitting, Barb Tube, 1/4" NPT, 3/8" HB | 333-0002-904 | 1        |

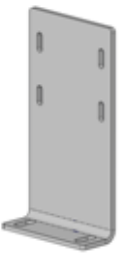
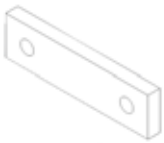
TABLE 2. Installation Hardware

| Item Image  | Part Description               | Part Number  | Quantity |
|---|--------------------------------|--------------|----------|
|  | Clamp, Worm Drive, Hose, 0.50" | 435-3003-002 | 2        |
|  | Clamping U-Bolt, 1-1/4"        | 435-3003-056 | 1        |

JDB-PF11-161 PARTS

TABLE 3. Installation Hardware

TABLE 4.



| Item Image  | Part Description                     | Part Number  | Quantity |
|---|--------------------------------------|--------------|----------|
|    | Bracket, Mounting Valve, HP AccuFlow | 107-0171-931 | 1        |
|    | Bracket, Support, Inlet Manifold     | 107-0172-305 | 1        |
|   | Bracket, Inlet Extension             | 107-0172-383 | 1        |
|  | Bracket, Cooler Support              | 107-0172-445 | 3        |
| No Image  | Hose, Supply, 13 Foot, 1.50", NH3    | 214-1001-052 | 2        |
|  | Coupler, Breakaway, 1.50", NH3       | 333-0002-307 | 2        |



TABLE 4.

|   |   |              |   |
|---|---|--------------|---|
|    | U-Bolt, 6.06" W x 5.00" L x 3/8" - 16 UNC | 107-0171-916 | 1 |
|    | U-Bolt, 2510 H                            | 107-0171-892 | 3 |
|    | Bolt, Hex, 3/8" - 16 UNC x 1.25" Long     | 311-0054-081 | 4 |
|    | Bolt, Hex, 5/8" - 11 UNC x 1.5" Long      | 311-0060-087 | 6 |
|  | Nut, Flange Lock, 3/8" - 16 UNC           | 312-1001-164 | 6 |
|  | Nut, Flange Lock, M16                     | 312-1001-178 | 6 |
|  | Nut, Flange Lock, 5/8" - 11 UNC           | 312-1001-179 | 6 |
|  | Fitting, 1.50" Swivel                     | 333-0001-031 | 2 |
|  | Fitting, 1/4" NPT x 3/8" Hose Barb        | 333-0002-904 | 1 |

TABLE 4.

|   |                                       |                     |          |
|---|---------------------------------------|---------------------|----------|
|  | <p>Clamp, Worm Drive, Hose, 0.50"</p> | <p>435-3003-002</p> | <p>2</p> |
|  | <p>Clamping U-Bolt, 1.25"</p>         | <p>435-3003-056</p> | <p>1</p> |

## UPDATES

Updates for Raven manuals as well as software updates for Raven consoles are available at the Raven Applied Technology Division web site:

[www.ravenhelp.com](http://www.ravenhelp.com)

At Raven Industries, we strive to make your experience with our products as rewarding as possible. One way to improve this experience is to provide us with feedback on this manual.

Your feedback will help shape the future of our product documentation and the overall service we provide. We appreciate the opportunity to see ourselves as our customers see us and are eager to gather ideas on how we have been helping or how we can do better.

To serve you best, please send an email with the following information to

[techwriting@ravenind.com](mailto:techwriting@ravenind.com)

- Accuflow Vortex Installation Manual
- P/N 016-0171-610 Rev. B
- Any comments or feedback (include chapter or page numbers if applicable).
- Let us know how long have you been using this or other Raven products.

We will not share your email or any information you provide with anyone else. Your feedback is valued and extremely important to us.

Thank you for your time.

# CHAPTER

# 3

# ACCUFLOW™ VORTEX COOLER ASSEMBLY

## ASSEMBLY OVERVIEW



**⚠ WARNING**

Anhydrous ammonia in vapor form can cause serious injury or death. Pipe joints must be properly sealed with thread sealant, to prevent leaks.

## INLET MANIFOLD ASSEMBLY

1. Apply thread sealant to all male threads.
2. Assemble the 2" pipe nipple into the cooler inlet.
3. Connect the ball valve to the pipe nipple. Verify that the ball valve is oriented so, when the valve is in the open position, the handle points away from the cooler assembly. The stop screw for the handle may need to move in order to close the valve.

FIGURE 1. Open Valve Handle Position

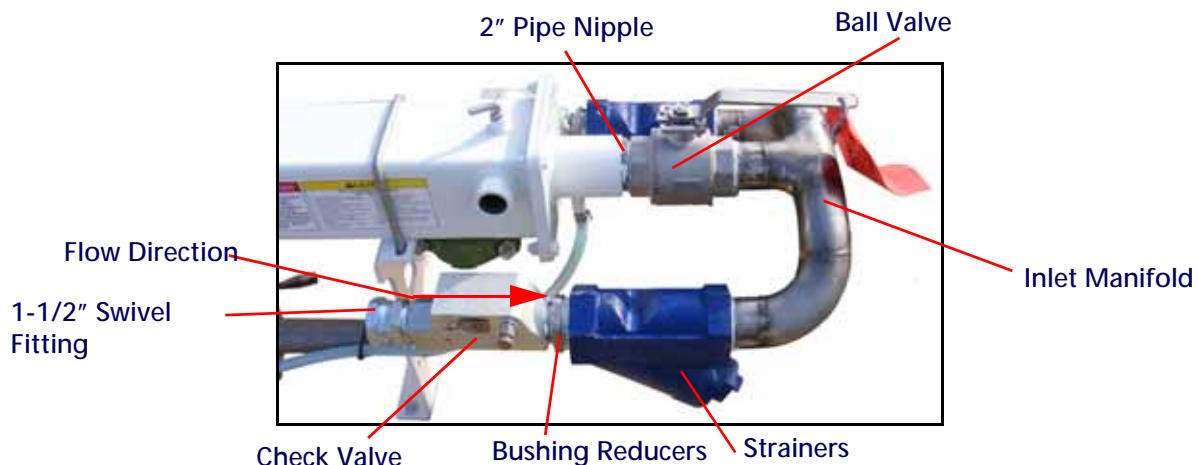

4. Attach the inlet manifold so the horns are offset below the cooler assembly.
5. Attach the strainers on the end of the inlet manifold.
6. Attach the 2" x 1-1/2" bushing reducer to the strainer.
7. Attach the check valve on the 1-1/2" end of the bushing reducer.

- a. Ensure the flow direction is correct.
- b. Assemble the check valve with the bleeder on the same side of the cooler as the gauges.

FIGURE 2. Bleeder Valve Location

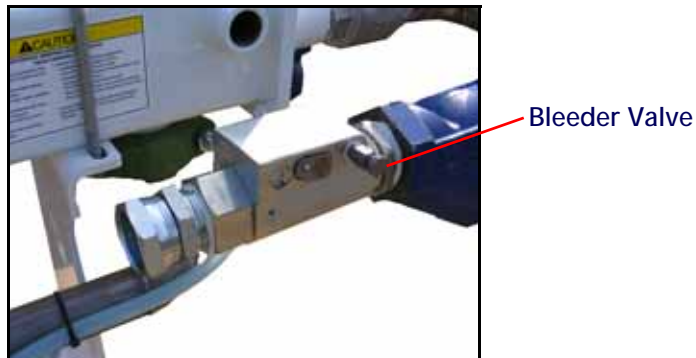

- c. Assemble the check valve with the pressure relief valve on the opposite side as the cooler gauges.

FIGURE 3. Proper Check Valve Orientation

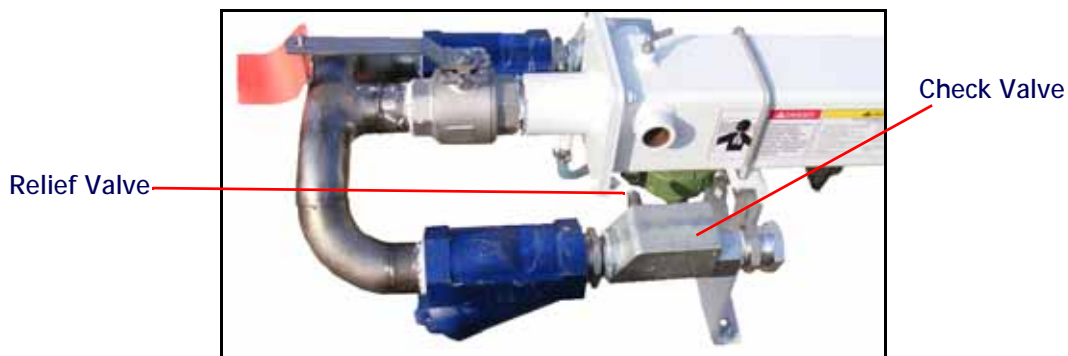

8. Attach the 1-1/2" swivel fitting to the end of the check valve.

---

## LEAK TEST

Prior to the installation on the tool bar, plug the system and perform a leak test with pressurized air (100 P.S.I. minimum/250 P.S.I. maximum) and soapy water.

---

## VAPOR PORT ASSEMBLY

1. Apply thread sealant to all male threads.
2. Screw the 1" pipe nipple into the vapor port on the AccuFlow™ Vortex.
3. Screw the cross fitting onto the 1" pipe nipple.
4. Install the two straight hose barbs so they run parallel with the side of the AccuFlow Vortex.
5. Install the 90° hose barb in the remaining port on the cross fitting.

FIGURE 4. Cross Fitting Assembly

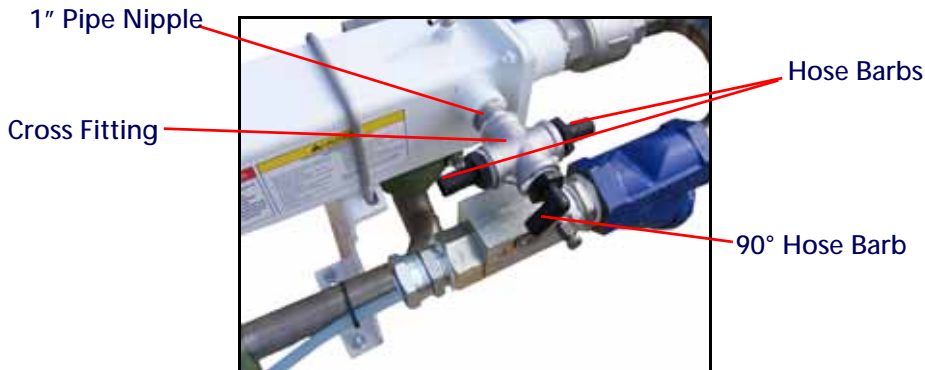
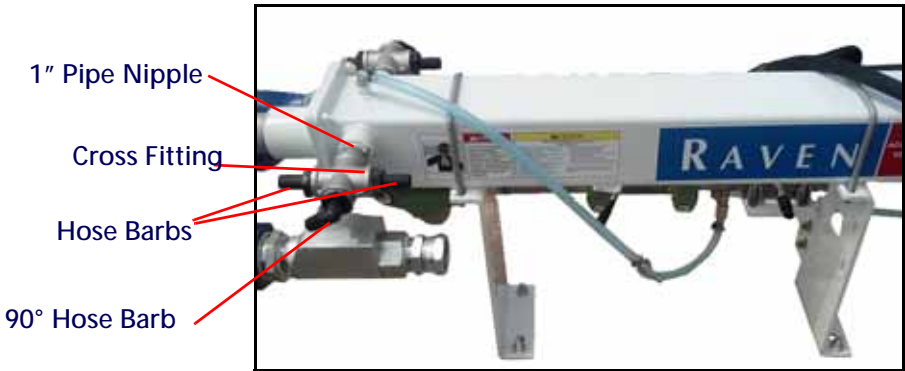

FIGURE 5. Cross Fitting Assembly





**ATTACHING COOLER TO MOUNTING BRACKETS**

1. Secure lifting straps on each end of the cooler at the locations identified in Figure 1.

**FIGURE 1. Proper and Improper Lifting Strap Location**

**Proper Lifting**



**Improper Lifting**



2. Attach the lifting straps to the hoist.
3. Slowly lift and maneuver the cooler into the installation location on the mounting brackets.

**11 AND 15 ROW**

1. Attach the mounting brackets in the location shown below.

**IMPORTANT:** Leave the mounting brackets slightly loose to allow for bracket adjustment.

**IMPORTANT:** Ensure the u-bolts do not cover the decals.

FIGURE 2. 11 and 15 Row Cooler Installation

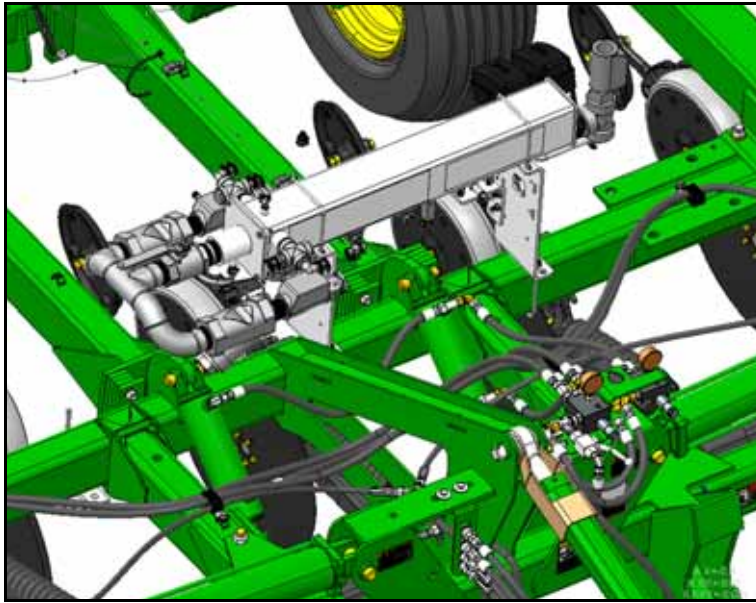

2. Secure the cooler to the mounting brackets and tighten all the hardware.

FIGURE 3. 11 and 15 Inlet Manifold Assembly

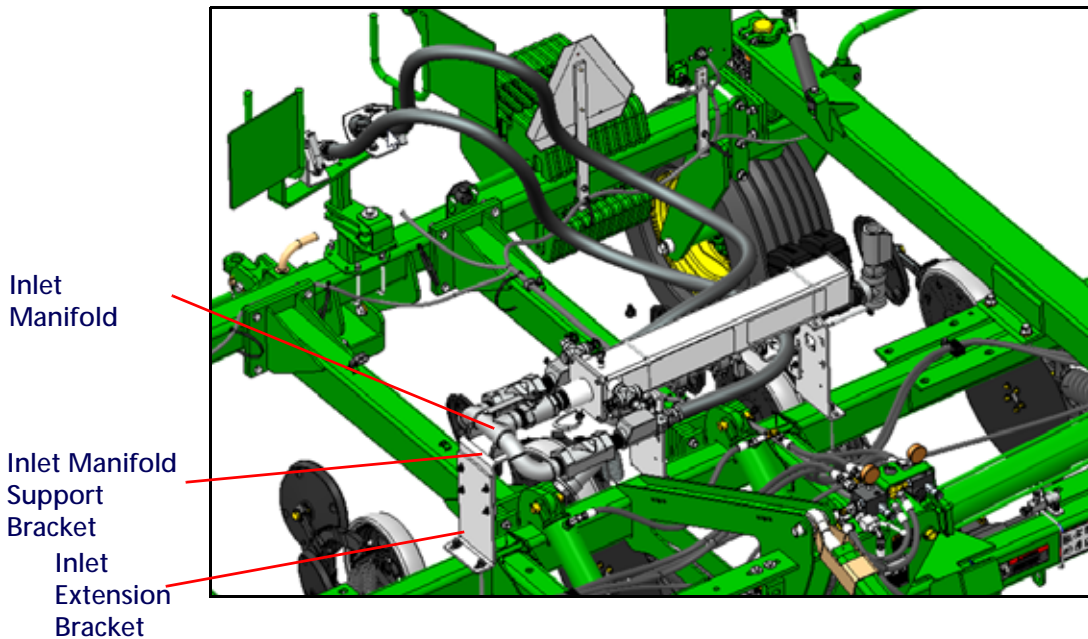

3. Secure the inlet manifold to the inlet manifold support bracket with the provided brackets and hardware.

### 23 ROW

1. Attach the mounting brackets in the location shown below.

**IMPORTANT:** Leave the mounting brackets slightly loose to allow for bracket adjustment.

**IMPORTANT:** Ensure that the u-bolts do not cover the decals.



---

FIGURE 4. 23 Row Mounting Bracket Installation

---



2. Secure the cooler to the mounting brackets and tighten all hardware.

---

FIGURE 5. 23 Row Cooler Installation

---



3. Secure the inlet manifold to the inlet manifold support bracket with the provided brackets and hardware.

FIGURE 6. 23 Row Inlet Manifold Mounting

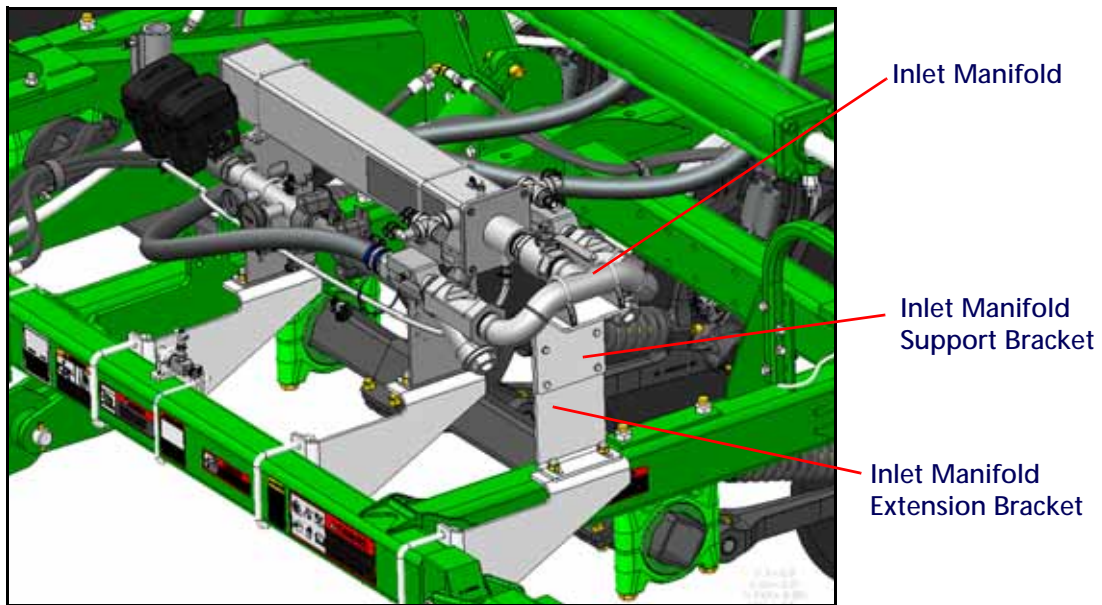

---

**IMPELLICONE ASSEMBLY**

**NOTE:** Section valves, impellicones, hoses, fittings, and mounting hardware are sold separately.

The following sections provide instructions for proper installation and mounting of the impellicones on the implement.

|   |                |
|---|----------------|
|    | <b>WARNING</b> |
| Anhydrous ammonia in vapor form can cause serious injury or death. Pipe joints must be properly sealed with thread sealant, to prevent leaks. |                |

1. Apply thread sealant to the all male threads.
2. Securely install the hose barbs and plugs into the ports on impellicone head. Space the barbs out as evenly as possible and seal any unused ports with plugs.

**FIGURE 1. Impellicone with Alternating Barbs and Plugs Installed**



3. Screw the impellicone to one end of the 8" pipe.
4. Screw the 90° elbow to the 8" pipe.
5. Screw the 1" x 2" pipe into the open end of the 90° elbow.
6. Screw the On/Off valve to the 1" x 2" pipe. Ensure that the flow direction is correct.

FIGURE 2. Pipe and 90° Elbow Assembly

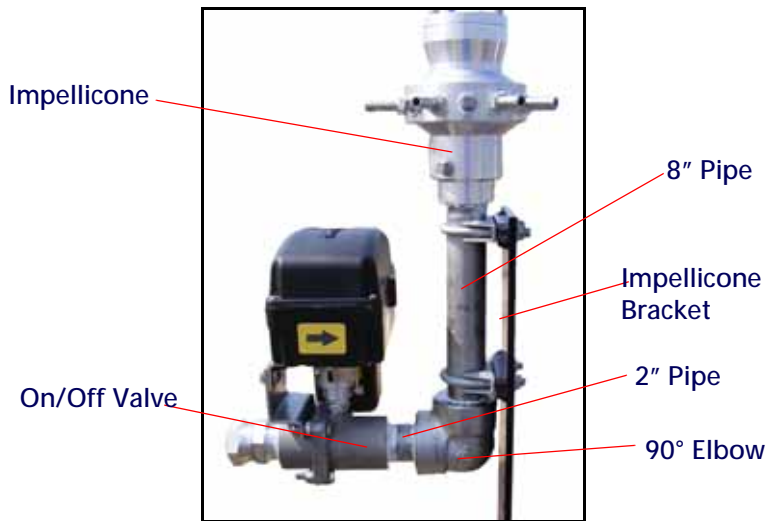

7. Mount the impellicone assembly to the mounting bracket using two clamping u-bolts.
8. For multi-section, a check valve with bleed valve and relief valve must be installed to the cooler outlet.

FIGURE 3. Check Valve Installation

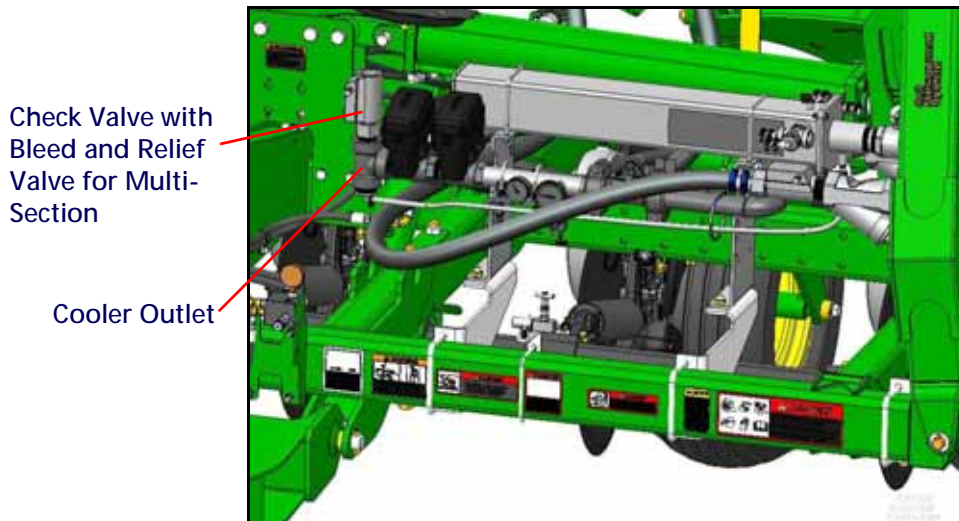

### DUAL IMPELLICONE EXAMPLE

1. Attach the impellicone mounting brackets to the frame of the toolbar ensuring that the hose will be able to reach the selected bracket mounting location.

FIGURE 4. Dual Impellicone Mounting Example

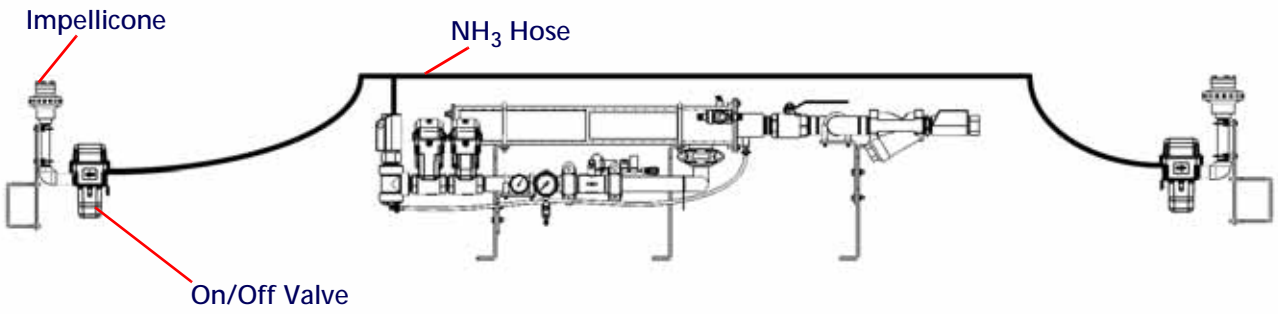



---

# CHAPTER

# 6

# HOSE & SUPPLY LINE INSTALLATION

---

1. This chapter contains instructions for connecting the AccuFlow Vortex system row and vapor tubes to a John Deere toolbar and connecting the NH<sub>3</sub> supply lines.

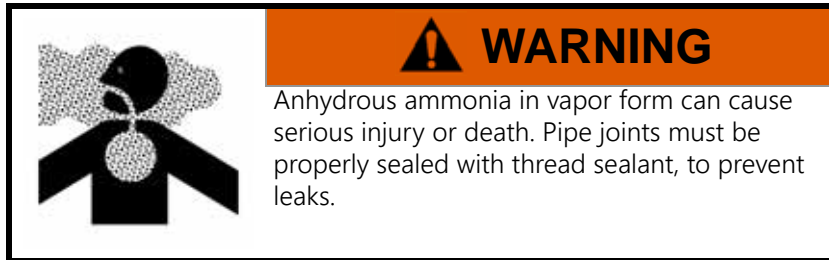

---

## SUPPLY LINE INSTALLATION

1. Route the 1-1/2" NH<sub>3</sub> supply lines to the AccuFlow™ Vortex.
2. Install the 1-1/2" NH<sub>3</sub> supply line hoses to the break away couplers.
3. Connect the other end of the supply lines to the 1-1/2" swivel fittings at the cooler inlet.
4. Secure the 1-1/2" hoses with P-clamps.

FIGURE 1. 11 and 15 Row Supply Line Installation

---

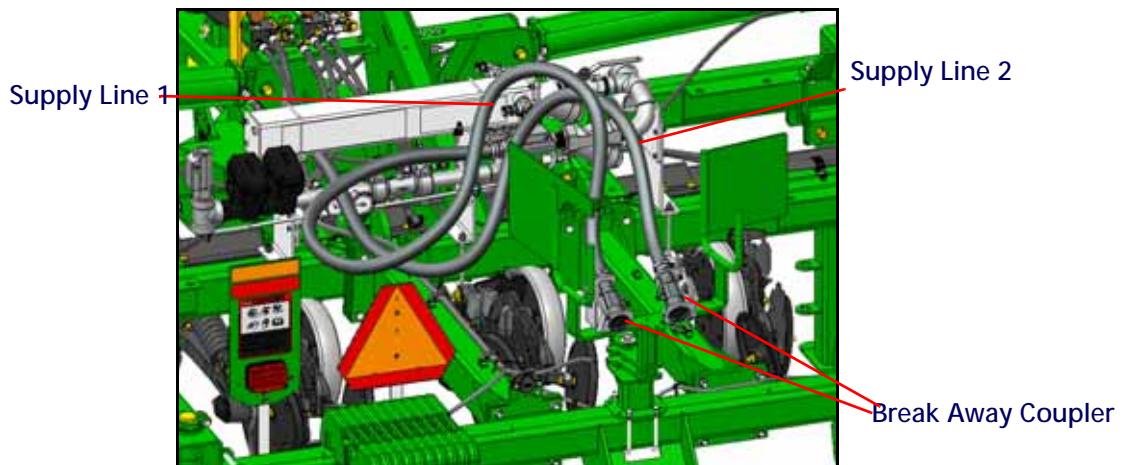

FIGURE 2. 23 Row Supply Line Installation

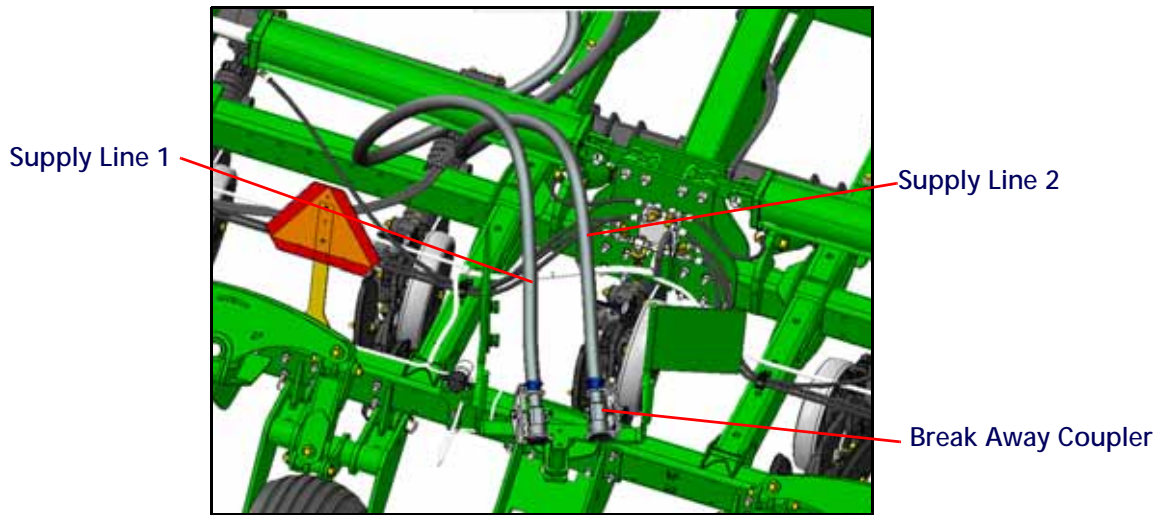
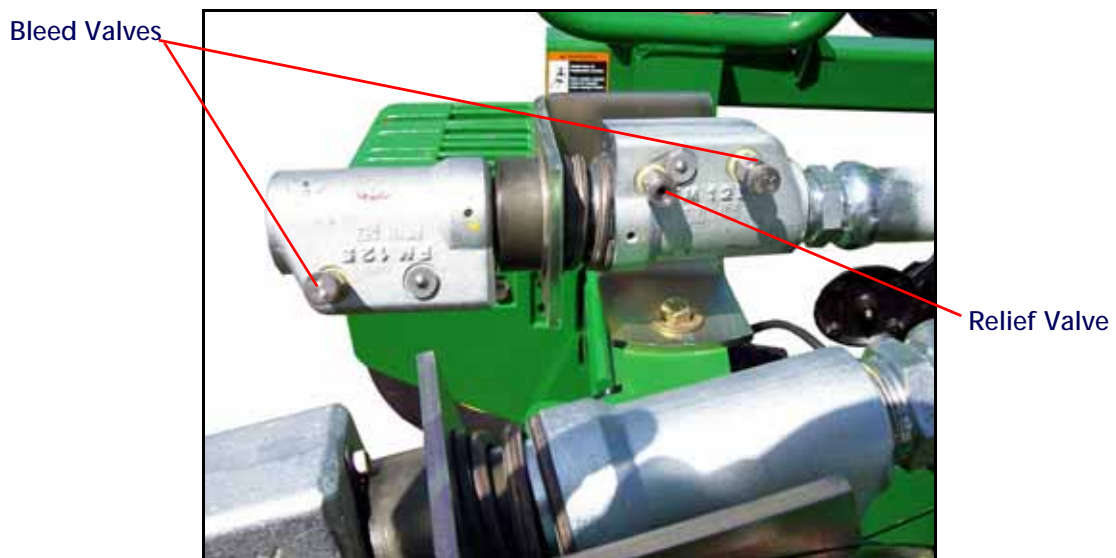

FIGURE 3. Breakaway Bleed Valve Installed



## APPLICATOR LINE INSTALLATION

1. Unfold the toolbar and lower knives as far as possible.
2. Measure the length of hose required to connect the impellicone and the applicator tube on the row furthest from the impellicone.
3. Cut the required number of applicator lines necessary to connect each of the toolbar knives to the impellicone. Each line must be equal in length to the longest applicator line.



FIGURE 4. Application Hose Cut to Equal Lengths



4. Connect the applicator lines to the pre-installed knives for each row and attach it to the knife using a hose clamp.

FIGURE 5. Application Hose Routing and Connection



5. Use the P-clamps to secure the applicator hoses to the toolbar.

FIGURE 6. Hydraulic Hose Clamp



**NOTE:** Allow for generous radius at folding points to keep hose from kinking or stretching when implement is folded or unfolded. After hose installation is complete, carefully fold and unfold the toolbar and verify hoses do not interfere with, or will be damaged by, operating the folding functions of the toolbar.

6. Horizontally coil the excess applicator hose and secure it to the non-folding center section of the toolbar.
7. Connect the applicator lines to the impellicone using the supplied hose clamps.

FIGURE 7. Liquid Applicator Lines Connected to Impellicone



## VAPOR LINE INSTALLATION

1. Route a vapor hose to the furthest vapor tube and cut to length.
2. Measure the length of the vapor line routed in step 1.
3. Cut all required vapor hoses to the length obtained in step 2.
4. Route all the vapor hoses to the vapor tubes.
5. Secure the vapor hose to the frame using existing P-clamps. Use additional steel straps or P-clamps as needed.
6. Connect the vapor hose to the vapor ports on the cooler.

## BLEED LINE HOSE ROUTING

1. Apply thread sealant to all male threads.
2. Route the bleed hose to the front of the tool bar.
3. Use the supplied mounting bracket, u-bolts, and nuts to secure the bleed hose.

FIGURE 8. Secured Bleed Hose



FIGURE 9. Attached Bleed Hose

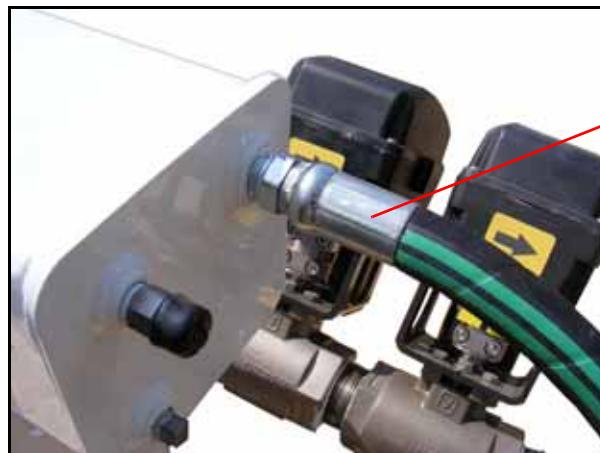

Bleed Line

4. Connect one end of the 1/2" high pressure hose to the back of the Vortex cooler and the other end to the needle valve.
5. Connect the 3/8" low pressure hose to the other side of the needle valve.
6. Route the 3/8" low pressure hose to the 3/8" hose barb tee near the cooler. This will turn the bleed off into the cooler's vapor chamber.

## EMERGENCY SHUT-OFF ROPE INSTALLATION

1. Use the provided quick link on the shut-off handle to securely tie a length of rope to the emergency shut-off valve quick link on the cooler.
2. Route the rope so that it is accessible from the tractor cab and, when pulled, the emergency shut-off valve closes completely.

FIGURE 10. Emergency Shut-off Rope Installation

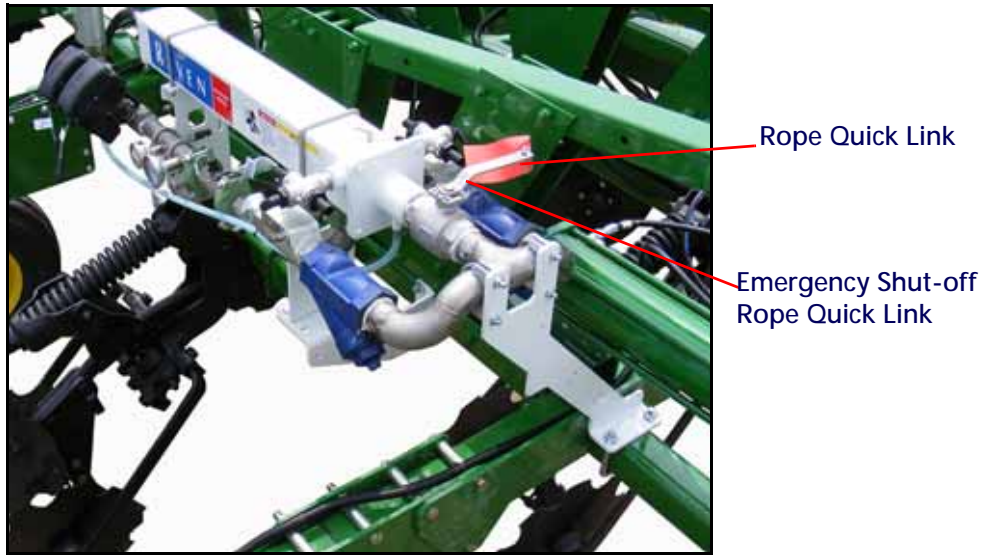

---

# CHAPTER

# REPLACEMENT PARTS

## 7

---

### REPLACEMENT PARTS

**TABLE 1. Inlet Plumbing Components**

| Part Number  | Description  |
|--------------|--|
| 063-0173-627 | 2" Inlet Shutoff Valve                             |
| 063-0173-655 | 2" Y-Strainer (Strainer ,Screen, Gaskets, Magnets) |
| 063-0173-691 | Back Check Valve W/ Relief                         |
| 063-0173-692 | Back Check Valve W/ Bleed Valve                    |
| 116-0159-755 | 2" Inlet Manifold Reversed                         |
| 219-0000-161 | 2" Strainer Gasket                                 |
| 333-9000-071 | 40 Mesh Strainer Screen                            |
| 418-0000-001 | Strainer Magnet                                    |

**TABLE 2. Vortex Cooler and Bleed Components**

| Part Number  | Description   |
|--------------|---|
| 063-0173-663 | Vortex Cooler Assembly (Cooler, Decals, Relief Valve) |
| 117-0171-591 | Seal/Hardware Kit                                     |
| 117-0171-592 | Decal Kit   |
| 214-0001-049 | Hose, 12', 1/2", NH3                                  |
| 333-0006-038 | 2-1/2" Gruv-Lok Coupling w/Gasket                     |
| 334-0001-064 | 1/4" Bleed Valve                                      |
| 334-0002-005 | Relief Valve  |
| 116-0159-752 | Weldment, Outlet Manifold                             |

**TABLE 3. Flowmeter Components**

| Part Number  | Description                             |
|--------------|---|
| 063-0171-669 | Flowmeter Sensor Assembly w/Nut         |
| 063-0173-618 | RFM 60SG Flowmeter                      |
| 117-0171-590 | RFM 60SG Internal Replacement Parts Kit |
| 333-0006-039 | 2" x 1-1/2" Gruv-Lok Coupling w/Gasket  |

**TABLE 4. Gauge Tree and Sensors Components**

| Part Number  | Description  |
|--------------|--|
| 116-0159-743 | 1-1/2" Gauge Tree Manifold   |
| 417-0001-030 | 0-250 PSI Pressure Gauge   |
| 417-0001-031 | -40F - 120F Temperature Gauge  |
| 422-0000-090 | Transducer, Pressure, 0-250 PSI, 1/4" MNPT, Stainless Steel (Metri-Pack) |
| 422-0000-119 | Transducer, Pressure, 1-5 V, 0-250 PSI, 1/4" NPT (Deutsch)               |

**TABLE 5. Control and On/Off Valve Components**

| Part Number  | Description                           |
|--------------|---------------------------------------|
| 063-0173-664 | Standard Control Valve Motor Assembly |
| 063-0173-665 | On/Off Motor Assembly                 |
| 063-0173-667 | 1-1/2" Standard Control Valve         |
| 063-0173-668 | 1-1/2" On/Off Valve Assembly          |
| 117-0171-219 | Valve Position Indicator Kit          |

**TABLE 6. Supply Hoses, Break-Away, Splitter, Section Manifold Components**

| Part Number  | Description   |
|--------------|---|
| 214-0001-048 | Hose Supply, 10', 1.5", NH3                         |
| 333-0001-031 | Fitting, 1-1/2" Swivel                              |
| 214-0001-052 | Hose, Supply, 13', 1.5" Diameter, Anhydrous Ammonia |
| 333-0002-307 | Coupler, Breakaway, 1-1/2" NH3                      |

# RAVEN

## Limited Warranty

---

### ***What Does this Warranty Cover?***

This warranty covers all defects in workmanship or materials in your Raven Applied Technology Division product under normal use, maintenance, and service when used for intended purpose.

### ***How Long is the Coverage Period?***

Raven Applied Technology products are covered by this warranty for 12 months from the date of retail sale. In no case will the Limited Warranty period exceed 24 months from the date the product was issued by Raven Industries Applied Technology Division. This warranty coverage applies only to the original owner and is non-transferable.

### ***How Can I Get Service?***

Bring the defective part and proof of purchase to your Raven dealer. If the dealer approves the warranty claim, the dealer will process the claim and send it to Raven Industries for final approval. The freight cost to Raven Industries will be the customer's responsibility. The Return Materials Authorization (RMA) number must appear on the box and all documentation (including proof of purchase) must be included inside the box to be sent to Raven Industries.

### ***What Will Raven Industries Do?***

Upon confirmation of the warranty claim, Raven Industries will (at our discretion) repair or replace the defective product and pay for the standard return freight, regardless of the inbound shipping method. Expedited freight is available at the customer's expense.

### ***What is not Covered by this Warranty?***

Raven Industries will not assume any expense or liability for repairs made outside our facilities without written consent. Raven Industries is not responsible for damage to any associated equipment or products and will not be liable for loss of profit, labor, or other damages. The obligation of this warranty is in lieu of all other warranties, expressed or implied, and no person or organization is authorized to assume any liability for Raven Industries.

**Damages caused by normal wear and tear, misuse, abuse, neglect, accident, or improper installation and maintenance are not covered by this warranty.**



## Extended Warranty

### ***What Does this Warranty Cover?***

This warranty covers all defects in workmanship or materials in your Raven Applied Technology Division product under normal use, maintenance, and service when used for intended purpose.

### ***Do I Need to Register My Product to Qualify for the Extended Warranty?***

Yes. Products/systems must be registered within 30 days of retail sale to receive coverage under the Extended Warranty. If the component does not have a serial tag, the kit it came in must be registered instead.

### ***Where Can I Register My Product for the Extended Warranty?***

To register, go online to [www.ravenhelp.com](http://www.ravenhelp.com) and select Product Registration.

### ***How Long is the Extended Warranty Coverage Period?***

Raven Applied Technology products that have been registered online are covered for an additional 12 months beyond the Limited Warranty for a total coverage period of 24 months from the date of retail sale. In no case will the Extended Warranty period exceed 36 months from the date the product was issued by Raven Industries Applied Technology Division. This Extended Warranty coverage applies only to the original owner and is non-transferable.

### ***How Can I Get Service?***

Bring the defective part and proof of purchase to your Raven dealer. If the dealer approves the warranty claim, the dealer will process the claim and send it to Raven Industries for final approval. The freight cost to Raven Industries will be the customer's responsibility. The Return Materials Authorization (RMA) number must appear on the box and all documentation (including proof of purchase) must be included inside the box to be sent to Raven Industries. In addition, the words "Extended Warranty" must appear on the box and all documentation if the failure is between 12 and 24 months from the retail sale.

### ***What Will Raven Industries Do?***

Upon confirmation of the product's registration for the Extended Warranty and the claim itself, Raven Industries will (at our discretion) repair or replace the defective product and pay for the standard return freight, regardless of the inbound shipping method. Expedited freight is available at the customer's expense.

### ***What is Not Covered by the Extended Warranty?***

Raven Industries will not assume any expense or liability for repairs made outside our facilities without written consent. Raven Industries is not responsible for damage to any associated equipment or products and will not be liable for loss of profit, labor, or other damages. Cables, hoses, software enhancements, and remanufactured items are not covered by this Extended Warranty. The obligation of this warranty is in lieu of all other warranties, expressed or implied, and no person or organization is authorized to assume any liability for Raven Industries.

**Damages caused by normal wear and tear, misuse, abuse, neglect, accident, or improper installation and maintenance are not covered by this warranty.**