



INSTALLATION MANUAL

SBGuidance Varioploughs

CAN





Contents

Preface	4
Disclaimer	5
1. Instructions for installing the SBGuidance Varioploughs	6
1.1. Overview of CAN Plough Set components	7
1.2. Overview of CAN Tractor set plough components (optional)	8
1.3. Plough set (assembled)	9
2. Assembly of plough set.....	10
2.1. Mounting the angle sensor	10
2.1.1. Mounting the sensor in sensor bracket	10
2.1.2. Mounting the angle sensor to the frame	11
2.2. Checking the manifold	13
2.3. Mounting the manifold	14
2.4. Mounting the steering controller.....	14
2.5. Installing cables/wiring	15
2.6. CAN implement harness Plough (schematic)	16
3. Set-up and calibration.....	17
3.1. Set-up via the CAN tool	17
3.2. Determining the control speeds	19
3.3. Calibrating the plough width	21
3.4. Configuring the PID controller.....	22
3.5. Setting up the plough direction sensor (optional).....	22
3.6. Configurator set-up	23
3.7. Checking the centre.....	24
3.8. Checking the plough width.....	25



3.9.	How to use Autocalibration Plow Steering	26
3.10.	What does the Autocalibration plow steering do?	26
3.11.	When to use Auto Calibration	27
3.12.	Explanation Autocalibration plow steering	27
3.13.	Which version needed?	27
3.14.	How does Autocalibration for Plow Steering work	28
4.	Annexe	29
4.1.	Pin-OUT of the STU – Plough Steering	29
4.2.	Pin-OUT of angle sensor	30
4.3.	Wiring scheme tractor set ploughs (schematic)	31



Preface

This installation manual is intended for persons responsible for installing an SBGuidance Varioplough set. The manual contains important instructions that should be complied with when commissioning, operating and servicing the SBGuidance system.

This manual has been compiled with the utmost care. SBG Precision Farming assumes no responsibility for any errors or omissions in this document.

Any comments or questions can be sent to info@sbg.nl.

SBG Precision Farming or any of its suppliers will accept no liability for physical or material damage caused whilst using the SBGuidance system.



Disclaimer



Warning!:

Always switch off the tractor before installing or repairing hydraulic and electrical components of the SBGuidance system.



Warning!:

The safety instructions contained in the manuals of the tractor or implements must be complied with at all times.



Warning!:

It is strictly prohibited to use the SBGuidance system on public roads.



Warning!:

It is strictly prohibited to leave a driving vehicle unattended whilst the SBGuidance operating system is switched on. The driver is always responsible for the direction and course of the vehicle.



Warning!:

To prevent injury or fire, replace defective fuses only with fuses of the same type and amperage.



Warning!:

The SBGuidance the operating system is not able to detect and avoid obstacles. If there is an obstacle in your path, you yourself will always need to take action for it to be avoided.



Warning!:

Only allow authorized/qualified persons to operate the system. Authorized/qualified persons are defined as: persons who have read and understood the manual, have been given instructions by a product specialist, and who are both physically and mentally fit and able to operate the system.



Caution!:

In order to prevent power surges from occurring, always start the machine first, before initializing the SBGuidance control system.



Caution!

Only touch the touch-screen with your finger or by using a special touch-screen stylus/pen. Operating the touch-screen with sharp objects may cause permanent damage to the screen.



Caution!

Always consult your supplier as to which products are best suited first before cleaning the touch-screen with chemicals or alcohol.

1. Instructions for installing the SBGuidance Varioploughs

This manual is a general guide and is not intended for any specific make or type. This chapter provides overviews of the standard components that can be supplied with the CAN tractor set.

All necessary parts are supplied, including this manual. Verify that all items listed on the packing list are actually present.



1.1. Overview of CAN Plough Set components

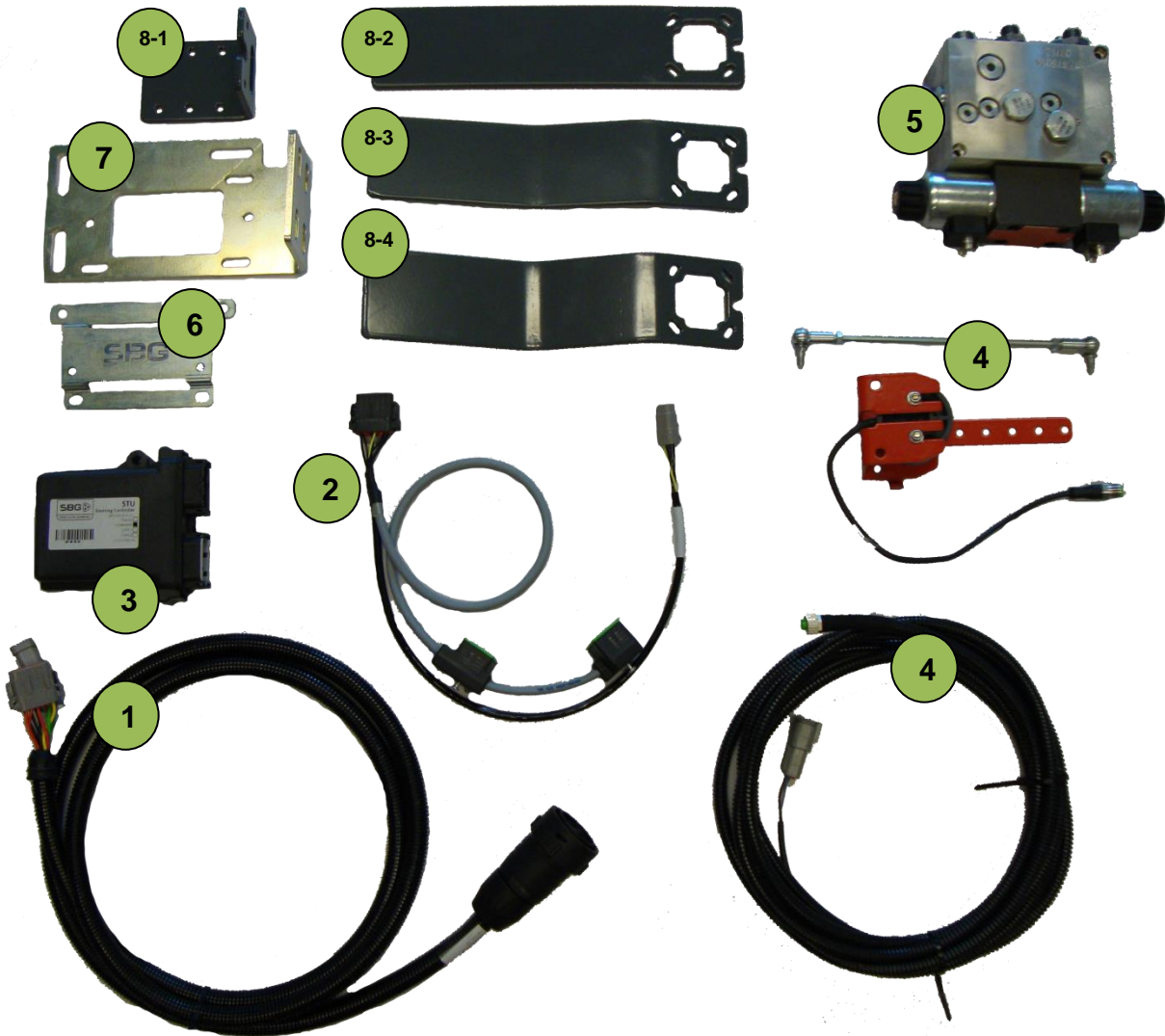

Symbol	Description
1	SBG13713-03 Implement harness plough
2	SBG13710-07 Hydraulic harness STU
3	SBG10919-02 STU – Plough Steering
4	SBG11900-04 Angle Sensor Cable + Angle Sensor 12V
5	SBG10690 Hydraulic manifold
6	SBG12705-05 STU bracket
7	SBG11823 / 11823-01 Manifold bracket
8-1	SBG11633 Angle sensor bracket 90°
8-2	SBG11630 Angle sensor bracket straight
8-3	SBG11631 Angle sensor bracket 3 cm offset
8-4	SBG11632 Angle sensor bracket 5 cm offset



1.2. Overview of CAN Tractor set plough components (optional)

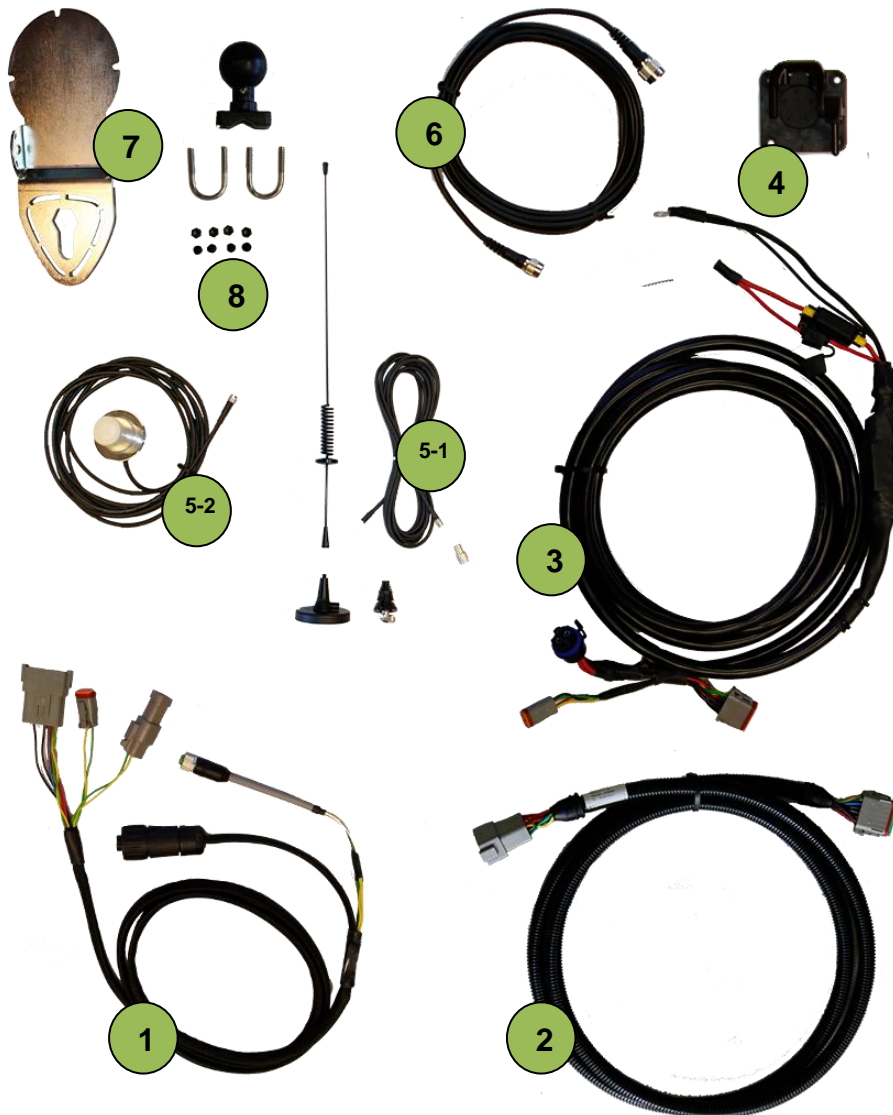

Symbol	Description
1	SBG13711-02 Harness in-cab (terminal)
2	SBG13711-20 Harness chassis (extension)
3	SBG13712-01 Power harness - Implement Ready (IR)
4	SBG13581-01 Implement socket (IBBC)
5-1	SBG10100-02 Antenna MMU4CX/L panel mount
5-2	SBG10385 GSM antenna LAIRD - 3.5M
6	SBG100 (42/43/44) GPS antenna cable (3/4.5/6 m)
7	SBG12198 GPS antenna bracket
8	SBG11043 RAM bracket terminal

i For the installation of the tractor components, refer to the SBGuidance Auto installation manual.



1.3. Plough set (assembled)

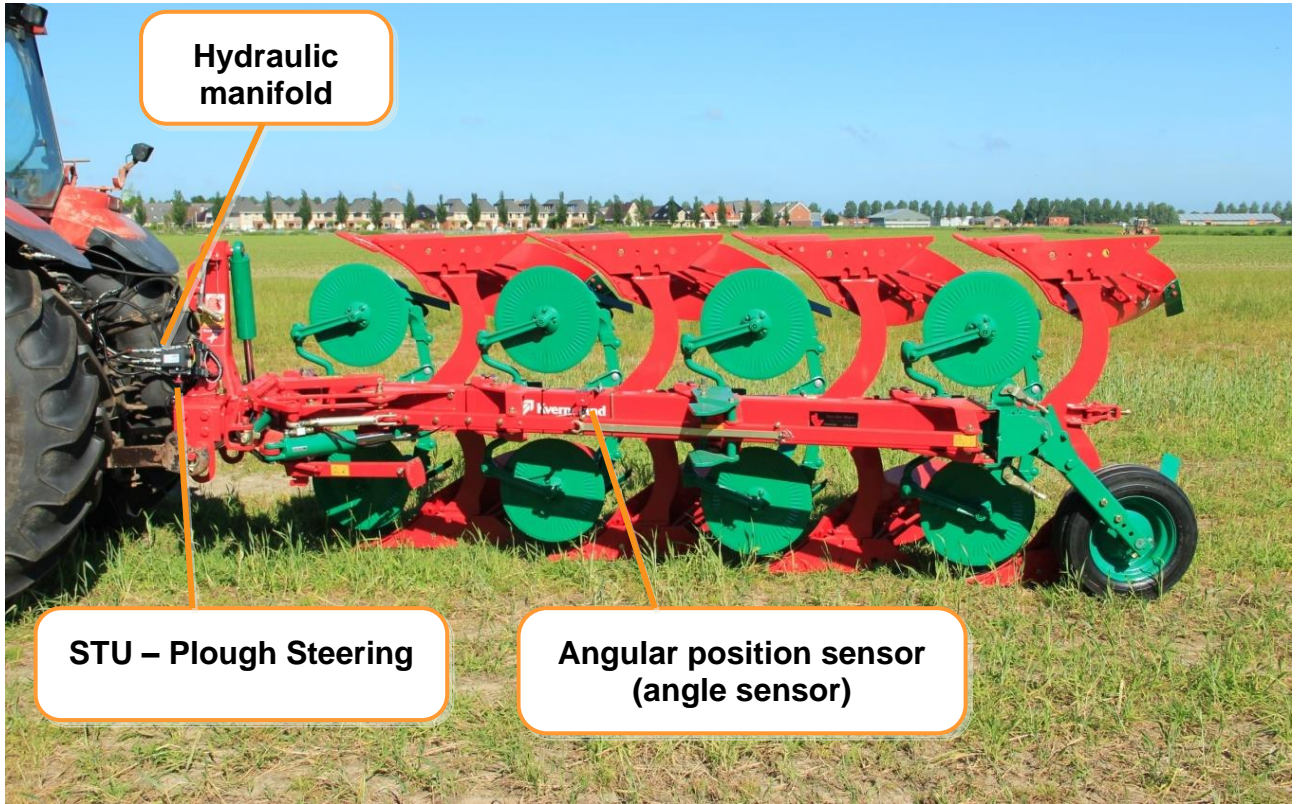



2. Assembly of plough set

It is recommended to assemble the plough set in the following order:

1. Mounting the angle sensor.
2. Checking the hydraulic manifold.
3. Mounting the hydraulic manifold and all hydraulics hoses.
4. Mounting the steering controller:
5. Installing the leads/wiring.

2.1. Mounting the angle sensor

Start by mounting the angle sensor. This measures the current plough width.

i *The angle sensor is already mounted in an angle sensor bracket when a plough control set is delivered (Figure 1).*

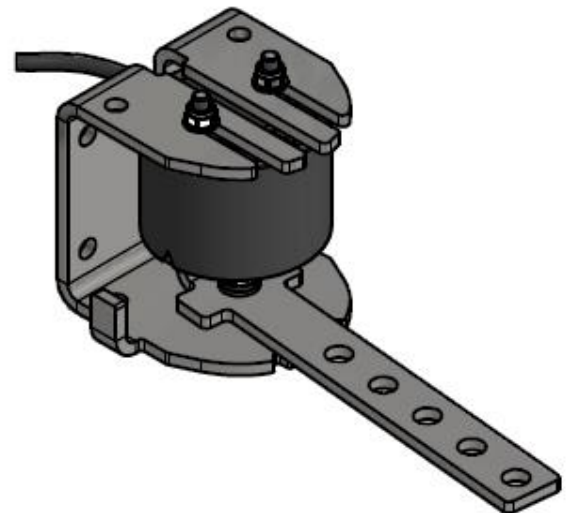

Figure 1 Angle sensor mounted in the sensor bracket

2.1.1. Mounting the sensor in sensor bracket

Follow the steps described below for mounting the angle sensor in the angle sensor bracket (Figure 2):

1. The sensor consists of two plastic parts which both need to be attached by means of M5 bolts. The smallest part needs to be attached to the sensor bracket with arm and the largest part needs to be attached to the other part of the sensor bracket.
2. The sensor bracket consists of two parts. Attach these two parts in the following order: M6 bolt, sensor bracket, chassis ring, sensor bracket, ring, spring-loaded ring and locking nut.

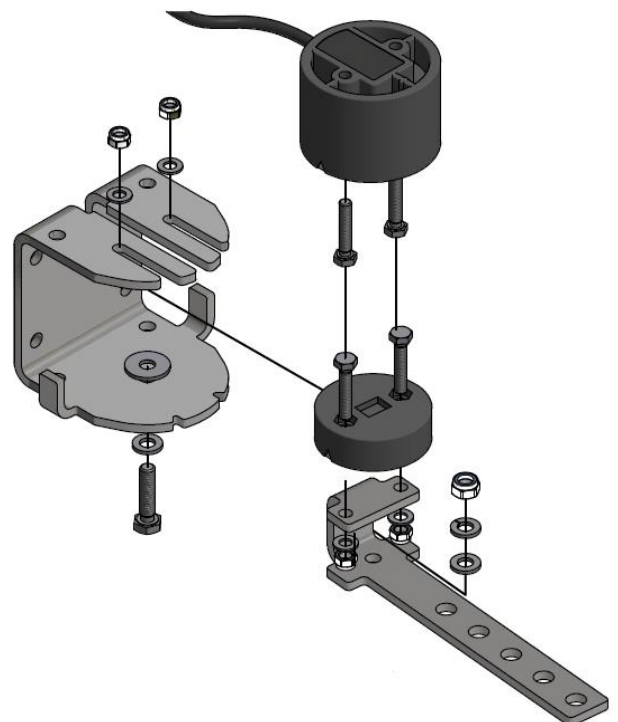

Figure 2 Mounting the angle sensor in the bracket



3. Tighten the locking nut firmly and then loosen a little so that the angle sensor is able to turn freely.

2.1.2. Mounting the angle sensor to the frame

1. Look for a place on the main chassis beam with enough space to allow the free movement of the sensor (Figure 3). The moveable width beam moves in relation to the main beam. Therefore, ensure that the arm of the angle sensor is able to move freely. The bracket for the angle sensor can be attached to the main beam with bolts. To do this, drill two 6.8 mm holes in the main beam and two 8 mm holes in the bracket. Tap an M8 screw thread in the 6.8 mm holes. If drilling is unsuccessful, the bracket can be welded to the main beam. Figure 4 shows the angle sensor mounted to a plough without moveable width beam. Figure 4 shows the angle sensor mounted to a plough without moveable width beam.



Figure 3 Angle sensor mounted to moveable width beam



Figure 4 Angle sensor mounted to plough without moveable width beam.

2. Determine the range of the angle sensor by marking off the width beam at the minimum and maximum plough width points.(Figure). Place the sensor arm in its central position in a downward direction. Set the plough to its maximum width and mark off this maximum position on the width beam. Then set the plough to its minimum width and mark off this position on the width beam. The measuring range is the distance between these marks. Mark off the centre of this range and place the plough in the centre position so that the arm corresponds to this mark.

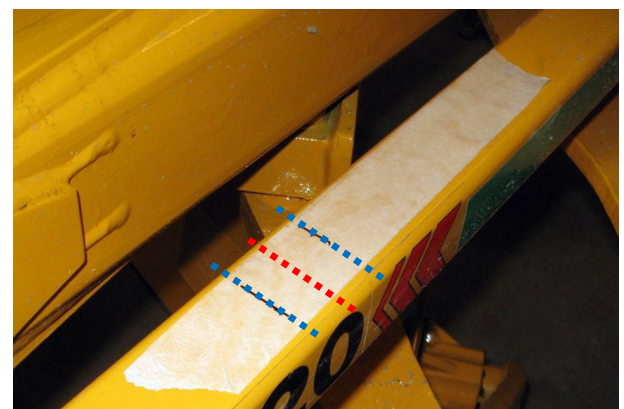

Figure 5 Range of the angle sensor on width beam.

- Place the plough and the angle sensor in the central position. Choose the hole in the sensor arm, depending on the range of the angle sensor. See Table 1 and Figure 6. Selecting the best possible hole ensures that the greatest possible voltage range is reached for the sensor. The correct position of the ball joint in the width bar can now be determined. Mark off the position where the ball joint will be attached. Drill a hole here and tap a screw thread.

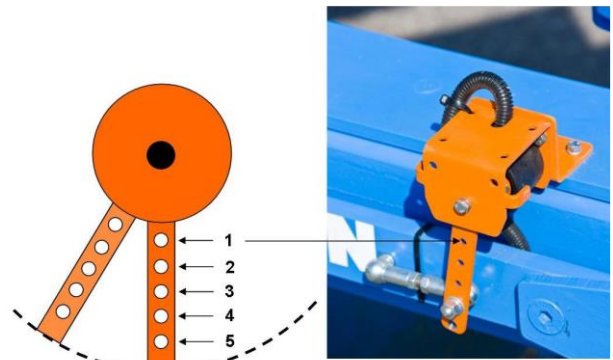

Figure 5 Holes in angle sensor arm

Table 1 Holes in angle sensor arm

Range sensor (cm)	Hole to be used in angle sensor arm
< 3.5	1
3.5 – 5.5	2
5.5 – 7.5	3
7.5 – 9.5	4
9.5 – 12.5	5

- After mounting, check whether the sensor can move freely and whether the movement remains within the linear measuring range (1.0 – 4.0 V) of the sensor.
- Then attach the sensor lead inside a protective tube along the plough towards the front. Ensure that the lead is not constricted or obstructed in any way when adjusting the plough width or when revolving the plough.



2.2. Checking the manifold

The hydraulic manifold can be used either in Load-Sense (LS) or Open Center (OC) mode. A selector plug must be used in the manifold, depending on the type of hydraulics used (Table 2, Figure 7). Check the type of selector plug (Figure 6) before mounting the manifold to the plough.

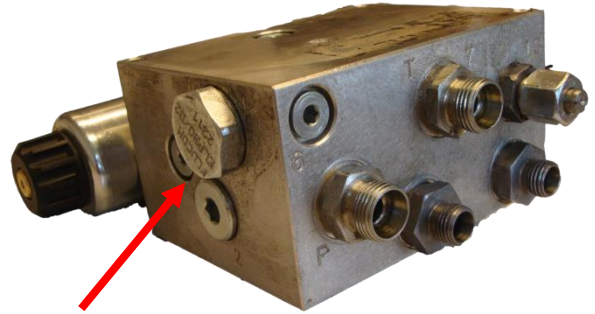

Figure 6 Selector plug

Table 2 Selector plug manifold

Type of hydraulics	Selector plug
Load Sense	SBG10810 Blind plug without imprint
Open Center	SBG10820 ELP30/D2

If the manifold is connected to the quick connectors at the rear of the tractor (external valve), the manifold must be configured to Open Center mode. The LS connection must be capped.



Figure 7 Selector plug. Left: LS. Right: OC

! *When Open Center is chosen, other selector plugs need to be used in the manifold than when Load Sense is used!*

The implement manifold is normally equipped with two dual controlled check valves (Flucom CAP20/M). If the hydraulic system of the plough uses dual controlled check valves, these must be removed from the manifold and be replaced by blind plugs (Figure 8).



Figure 8 Top: blind plug; Bottom: dual controlled check valves (Flucom CAP20/M)

i *The dual controlled check valves must be removed from the manifold if the hydraulic system of the plough is already fitted with dual controlled check valves.*

2.3. Mounting the manifold

3x M8 internal threads are already present in the manifold for mounting purposes. Attach the manifold to the manifold bracket supplied (Figure 9).

Place the manifold on the 3-point long beam of the plough in such a way that the hydraulics hoses can be easily directed towards the tractor. Ensure that the DIN connectors on the proportional valve can be connected after fitting the manifold. It is recommended to use quick connectors on the manifold for **A** and **B**. The plough width adjustment controls can also be connected if a tractor is for ploughing without the use of SBG equipment.

Load Sense

Connect the pressure line to **P**, the return line to **T** and the sensor line to **LS** on the manifold. Use the Load Sense (LS) connections of the tractor.

Open Center

Connect the pressure line to **P** and the return line to **T** on the manifold. Use the external hydraulics valve of the tractor.

2.4. Mounting the steering controller

The Steering Controller (STU) can be mounted to the manifold with the aid of an STU bracket. It is recommended to mount the STU and connectors in a downward direction. See Figure 9 for an example of how the STU is mounted.

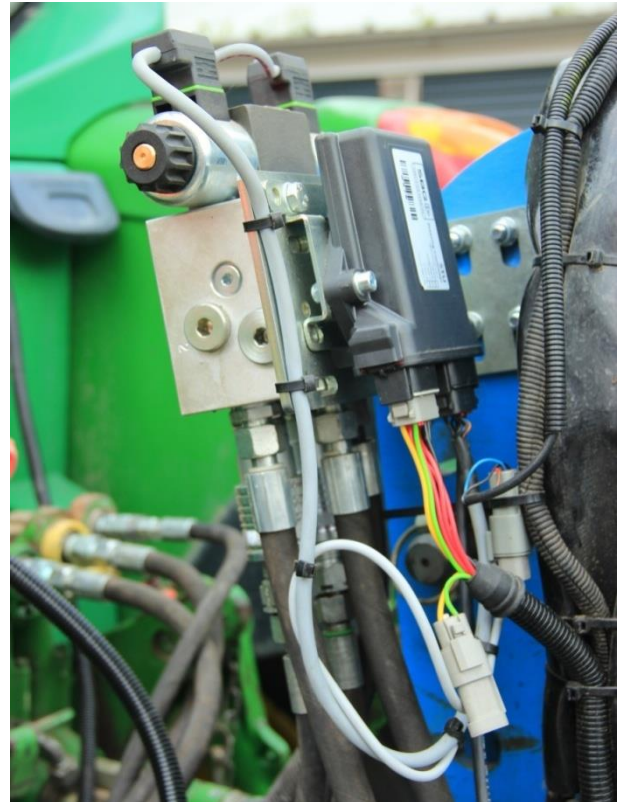

Figure 9 Manifold and Steering Controller mounted with the aid of supplied brackets



2.5. Installing cables/wiring

An Implement-ready wiring harness is required on the tractor for connecting the plough control. The IBBC connector can be used to connect the plough control (Figure 10).

Section 2.6 shows a schematic view of the connecting circuit. The CAN implement lead ensures that the STU – Plough Steering is connected to the tractor. In addition, the hydraulic harness needs to be connected to the STU. This hydraulic harness ensures the control of the proportional valve and the readout of the angle sensor.

Install the angle sensor lead along the plough width beam and hydraulic lines to the STU (Figure 11).

! *Mount the CAN implement lead in such a way that the separate conductors coming from the protective sleeve are directed downwards. This will prevent any penetration of water into the protective sleeve.*

i *Tip: Tie-wrap the leads so that they are attached free from vibration and friction.*

i *Tip: Install the leads so that they cannot be damaged.*

! *Press the connectors firmly into place until they click!*



Figure 10 IBBC bracket with connector



Figure 11 Installing angle sensor lead alongside the hydraulic lines

2.6. CAN implement harness Plough (schematic)

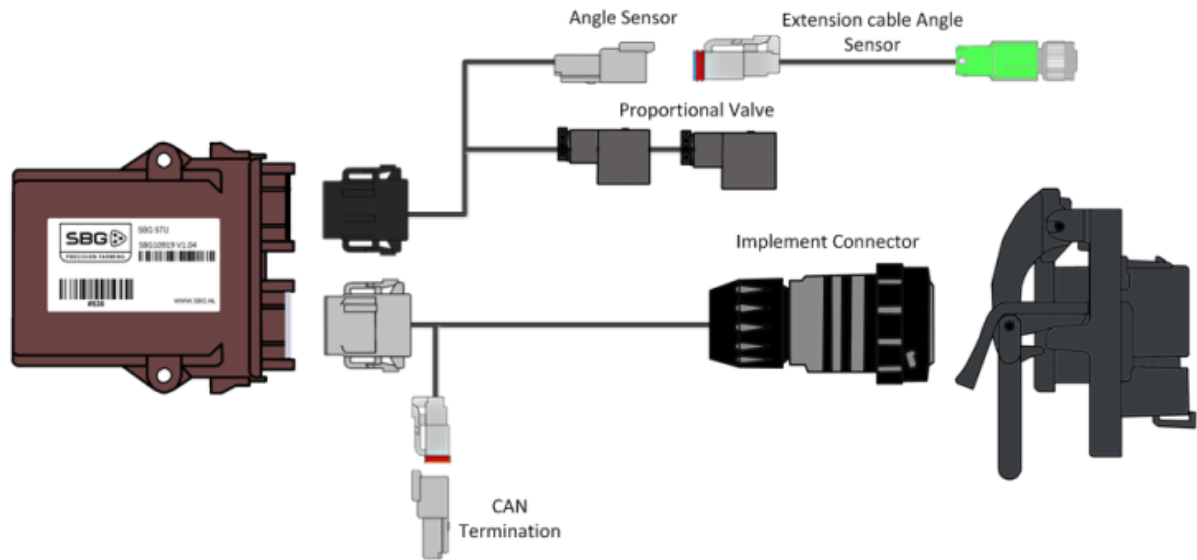

Figure 12 CAN Implement harness Plough



3. Set-up and calibration

The following software and firmware versions are required for the configuration, calibration and use of the CAN plough control unit:

- CAN-Tool 1.25 or more recent version.
- Plough control firmware *STU_Plough_1.1.0* or more recent version
- SBGuidance 3.6.0 or more recent version.

i Check the download page on www.sbg.nl for the most recent software and firmware versions.

i The STU – Plough Steering firmware can be updated from SBGuidance version 3.6.0 via the Configurator under CAN > Firmware Update. An alternative is to use the **Diagnostic Service Tool** pre-selection option in the CAN-Tool. Select **Navtronics** type for an STU.

3.1. Set-up via the CAN tool

Initialize the CAN tool. On Hardware, choose manufacturer “**SBG**” and press on *Initialize*. After initializing the connection with the CAN bus, a bus load will be displayed. Received frames must be in increasing increments. The bus load and received frames are displayed at the bottom of the screen. If this is not the case, check the lead connections.

Go to the tab page MyDevice (Figure 14) and on Pre-selection select “**Navigation Controller**”

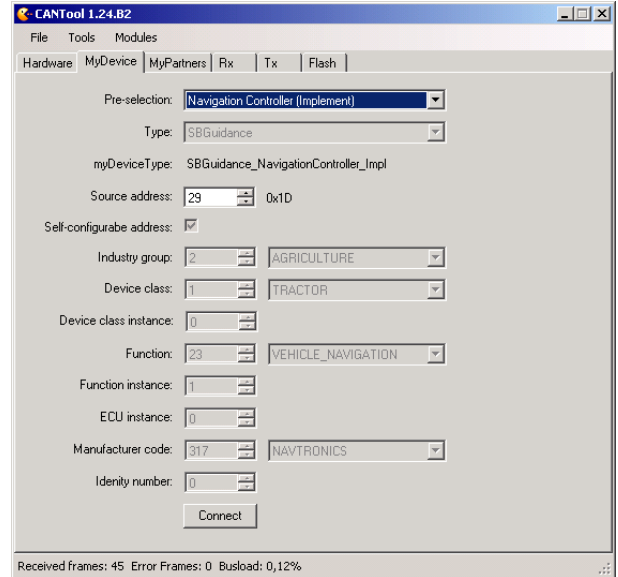

Figure 13 CAN-Tool MyDevice Implement Controller

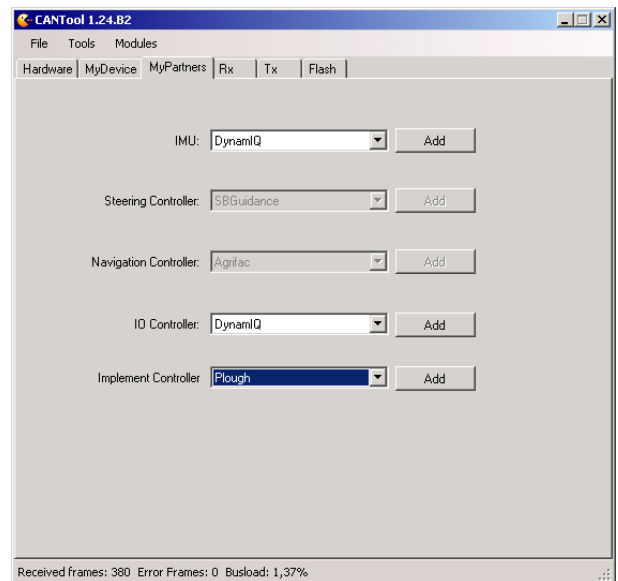

Figure 14 CAN-Tool MyPartners Plough



(Implement)". Then press on *Connect*.

Go to the tab page MyPartners (Figure 14). On Implement Controller, select "**Plough**" and press on "*Add*". This will open the set-up screen for the CAN plough control (Figure 15).

The steering controller is recognized if the status is on *Running*, if an *SW Version* is displayed and the correct type of STU is detected. In addition, a sensor value should be displayed and a yellow line should be visible in the graphic display. The sensor value should change when the plough width is adjusted.



Check whether the Steering Controller is recognized before you continue to set up and calibrate the plough control.

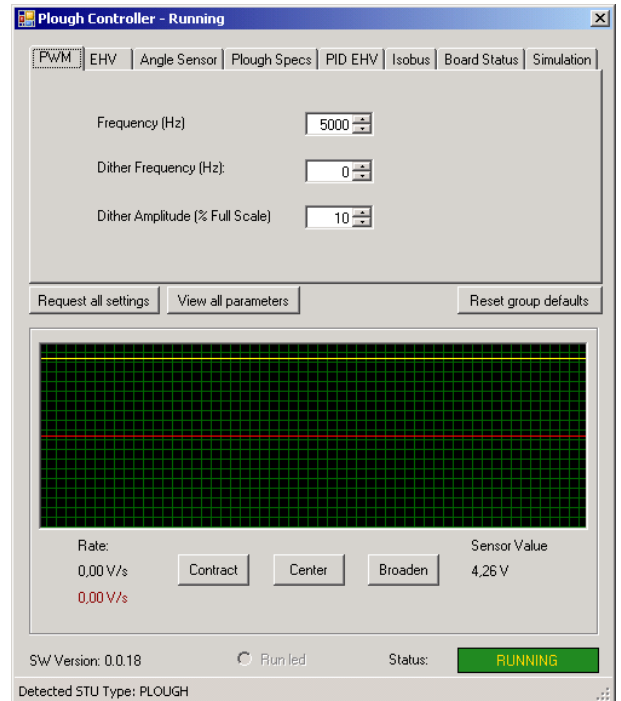

Figure 15 CAN-Tool Plough Controller



3.2. Determining the control speeds

By default, the manifold is equipped with a **proportional valve** (Figure 16). On the tab page EHV, select (Figure 17) type **PWM** for proportional control.

! When using a **black/white valve** the type of control should be set to **On/Off**. The maximum control values should then be set to 100%.

i Allow the oil from the tractor to warm up before starting the determination of the control rates.

i The control can be checked by pressing one of the Test buttons on the tab page EHV and by observing whether any of the LED lights on the DIN connectors light up.

Check whether the contracting or broadening of the plough width corresponds to the actual situation. Otherwise, check **"Invert steering"**.

Use the **"Test"** button to the right of the steering percentages to control the wheels at the maximum control speed. Start with the maximum control percentages set to 70% and decrease the values until the maximum control speed decreases.

! Set the maximum control percentages so that the actual maximum control speed is reached.

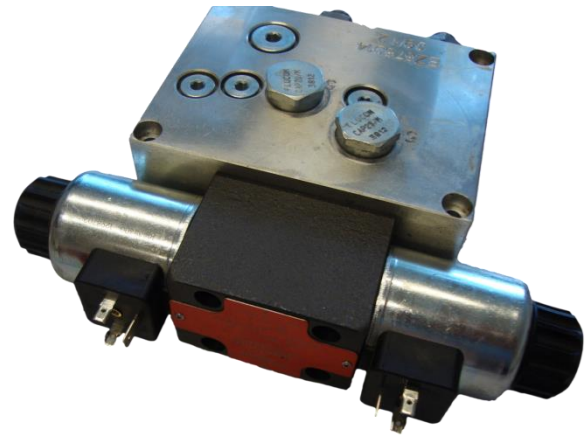

Figure 16 Implement manifold equipped with a proportional valve

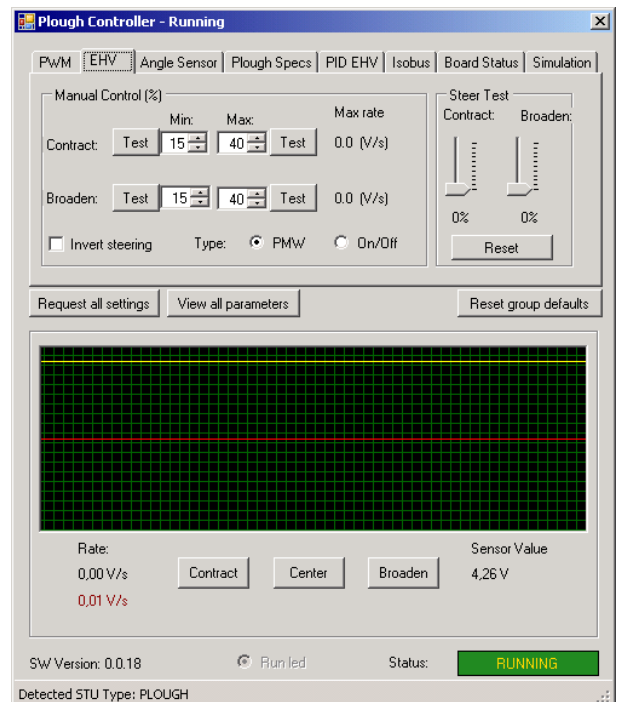

Figure 17 CAN-Tool tab page EHV



Use the “**Test**” buttons on the left of the steering percentages to control the ploughing width adjustment at the minimum control speed. Determine the control speeds for contracting and broadening independently so that both minimum control speeds correspond to approx. 0.05 V/sec.



Important: *The plough width adjustment must contract and broaden just as quick when the minimum control values apply.*



3.3. Calibrating the plough width

Calibration of the plough width is required to allow the measured sensor voltage to correspond to the total ploughing width.

1. Set up the plough in its **most contracted position** and record the sensor voltage by pressing on **Get** on the tab page Angle Sensor (20).
2. Set up the plough in its **broadest position** and record the sensor voltage by pressing on **Get** on the tab page Angle Sensor.
3. Measure the ploughing width in the **broadest position** across one or a multiple number of shares. To do this, it is handy to attach a steel tube with glue clamps to the mouldboard of the plough (Figure 18). Convert the measured width to the width across the entire number of shares. Enter the full plough width on the tab page Plough Specs under Maximum Plough Width (Figure 19).
4. Measure the plough width in the **most contracted position** across one or more shares. Convert the measured width to the width across the entire number of shares. Enter the full plough width on the tab page Plough Specs under Minimum Plough Width.

 *The plough width can also be calibrated using SBGuidance under Settings > Vehicle.*

 *After calibrating several plough widths (e.g. 35, 40, 45 cm) check whether the plough width corresponds to the actual plough width measured.*



Figure 18 Measuring the plough width



20 CAN-Tool tab page Angle Sensor

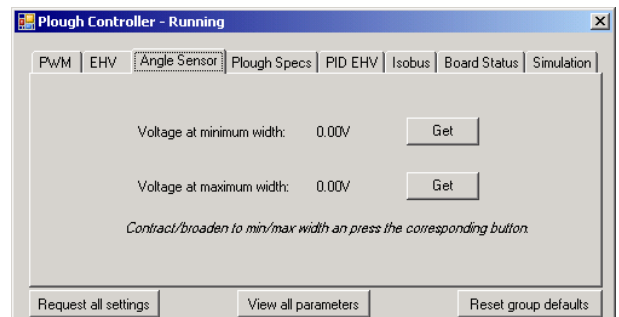
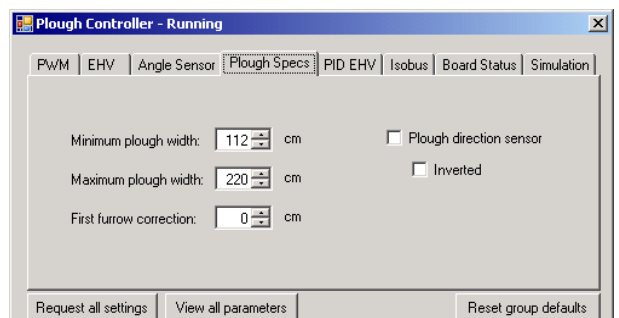

Figure 19 CAN-Tool tab page Plough Specs

3.4. Configuring the PID controller

On the tab page PID EHV (Figure 20) check the controller settings.

Gain = 100%
 Proportional gain = 10
 Integral gain = 0,01
 Differential gain = 5

i The user can adjust the response of the controls using the hydraulics settings in SBGuidance under Settings > Vehicle.

! **Attention!** The above only applies to proportional control.

3.5. Setting up the plough direction sensor (optional)

The use of a plough direction sensor (induction sensor) is optional. The plough direction or the rotating position of the plough is determined by the sensor that is mounted. On the tab page Plough Specs in the CAN-Tool, specify that a *Plough direction sensor* is used. Check that the position of the tractor corresponds to the graphic displayed in SBGuidance under Settings > Vehicle.

i A plough direction sensor can be fitted to the plough as an additional option. The sensor can be ordered as an optional part.

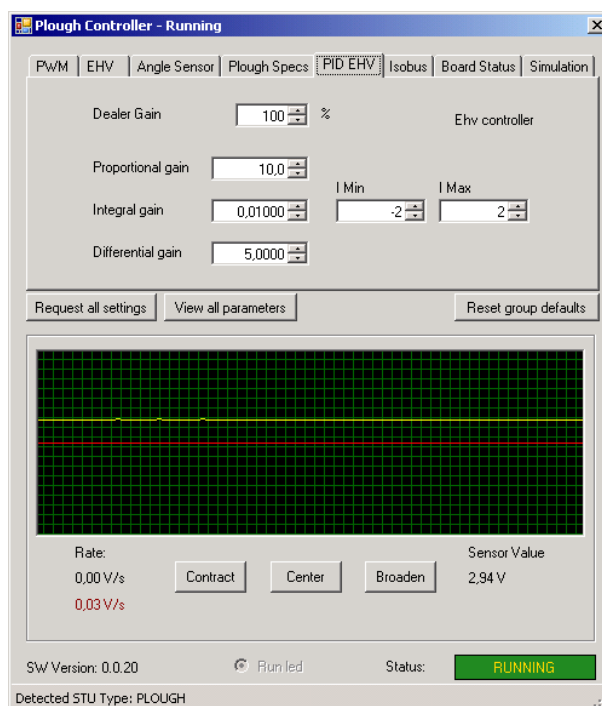

Figure 20 CAN-Tool tab page PID EHV



3.6. Configurator set-up

Use the latest software release of SBGuidance and install this on the C:/ drive of the terminal. Rename the SBGuidance folder so that the name of the client and the type of implement are included in the name. For example:
SBGuidance_Dekker_Kverneland_4schaar

Under Machine settings in the SBGuidance Configurator, set up and configure the system and implement guidance type. Select *System type* “**CAN**” and *Guidance type* “**SBGuidance Plough**”. No parameters are required on the tab page Plough.

On the tab page Machines, enter the offsets.
Offset A: above-ground height of the antenna
Offset E: distance between GPS antenna and rear axle
Offset L: wheelbase (distance between front and rear axle)

A DynamiQ can be used for ploughing as an additional option. The GPS position is then corrected to compensate for the roll of the tractor. The advantages of the use of a DynamiQ are the precise positioning on uneven surfaces, the use of the plough and ploughing operations, more precise operations at edges. If the tractor is already fitted with a DynamiQ, set up the use of “**DynamiQ**” under Machine settings on the General tab page of the Configurator, i.e. under *Orientation*. Tractors equipped with a CAN tractor set for automatic control are fitted with a DynamiQ.



Refer to the SBGuidance Auto CAN Set-up and Configuration Manual for further information on how to install SBGuidance.

3.7. Checking the centre

Drive the tractor back and forth over the same track in a field in order to determine the centre of the tractor. The centre can be adjusted with the aid of the centre adjustment, i.e. Offset D (in SBGuidance under Settings > Vehicle > Offsets). Checking the centre is important when ploughing back and forth with the same working width.

If a DynamiQ is used, the DynamiQ must first be calibrated before checking the centre. If the tractor is already equipped with a DynamiQ, this should normally already be calibrated. Otherwise, use the two-point calibration (Figure 21) in SBGuidance under Info > GPS > Orientation.

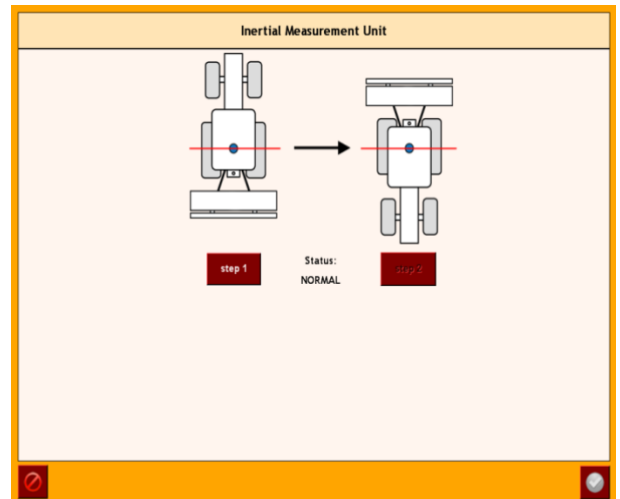

Figure 21 DynamiQ two-point calibration



3.8. Checking the plough width

If a different width is still ploughed when driving back and forth, even after checking the centre, it is then recommended to compare the actual plough width in the field with the current plough width displayed in SBGuidance.

1. Place a stake at about 3 metres from the ploughing furrow. In doing so, allow space for ploughing. Measure the exact distance between the ploughing furrow and stake.
2. Switch the plough control **off** and plough beyond the stake. Read the current plough width whilst ploughing.
3. Measure the distance between the stake and the ploughing furrow again. The difference between the two distances is the actual plough width.
4. If the actual plough width differs from the current plough width, then the first plough share is lifting more than the other shares. This can be compensated for by making corrections to the configuration of the first share. The *correction of the first share* can be entered in SBGuidance using the plough set-up wizard (Figure 22) under Set-up > Vehicle.



Instellingen ploegbesturing

Opties

Min. breedte: 150 cm

Max. breedte: 200 cm

Dode band: 2 cm

Correctie eerste schaar: 0 cm

Auto-Center: (0 cm)

Werkgang vasthouden:

1 / 2

Figure 22 Plough set-up wizard

3.9. How to use Autocalibration Plow Steering

- Have plowed at least 2 rounds so that the average cutting width of the plow is representative.
- In both working directions, press the Autocalibration button  In both working directions, press the Autocalibration button

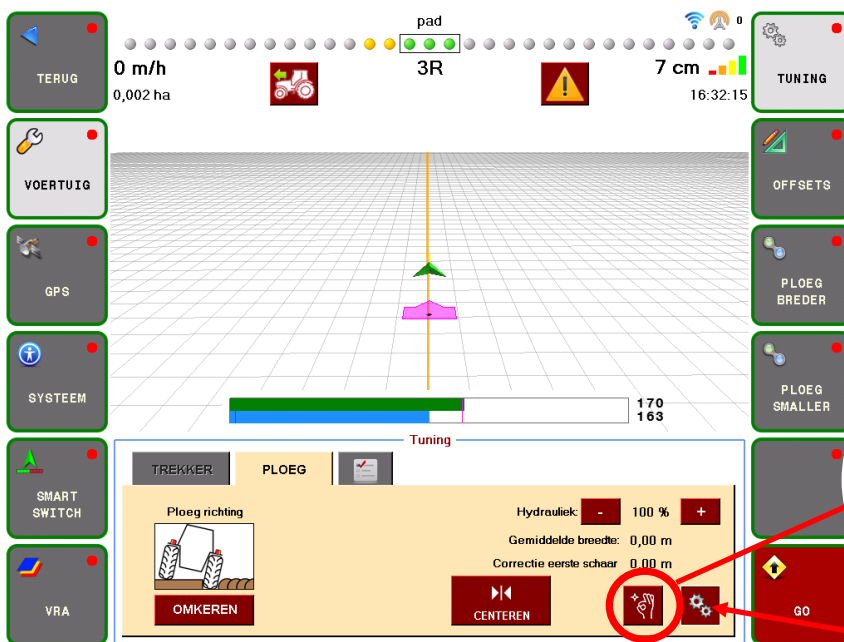

PAY ATTENTION! Press the Autocalibration button in both working directions once just before the end of the working pass.

PAY ATTENTION! Only use the Autocalibration after at least 2 rounds of plowing: When the average cutting width is representative.

 Button Auto Calibration plow steering

 Button settings for plow steering

3.10. What does the Autocalibration plow steering do?

When the Auto Calibration button is pressed, the plow settings will be adjusted based on the average width of the plow and the set working width of the field.

This is further explained in an example on the next page.



3.11. When to use Auto Calibration.

If the tractor deviates on average by more than 5 cm from the line during the working pass, the Autocalibration button can be pressed at the end of the working pass in the other working direction, at more than 10 to 15 cm you should adjust the plow.

3.12. Explanation Autocalibration plow steering.

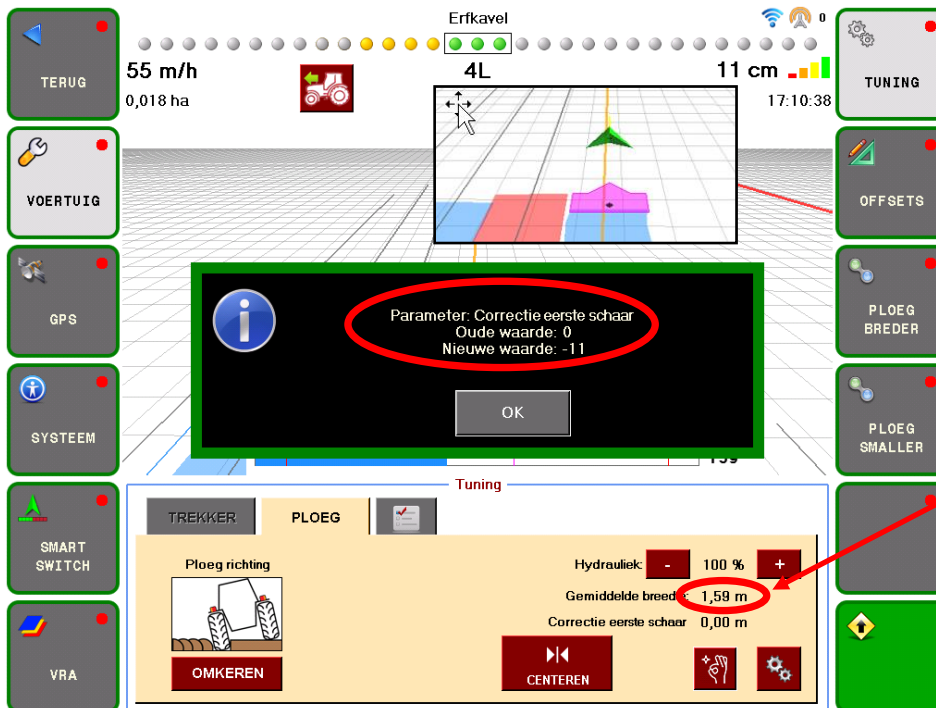

The auto-calibration button was pressed just before the end of the pass.

The set working width of this field is 1.70 meters.

The plow has plowed an average of 1.59 meters over the entire working pass.

3.13. Which version needed?

From SBGuidance 4.3.167 in combination with STU versie 4.4.9

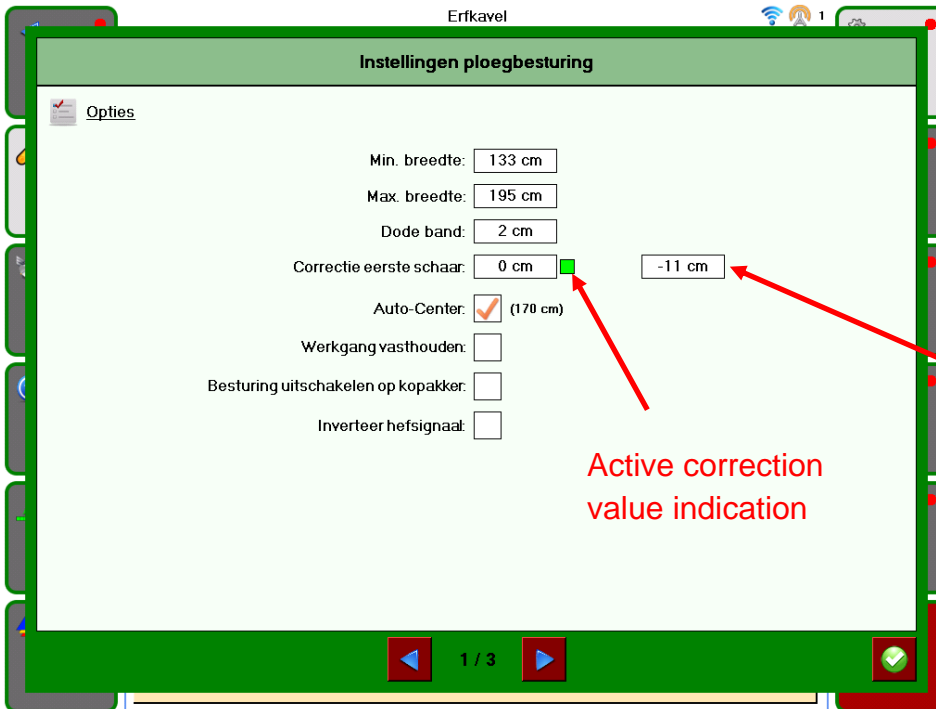

170 - 159 = 11 cm

The plow had to plow 11 centimeters narrower in this pass because the plow apparently plowed 11 cm too wide in the previous pass.

To correct this, the Autocalibration enters a value of -11 cm in Correction first furrow of the other working direction.

That is the NOT active Correction first furrow (without green indication)

3.14. How does Autocalibration for Plow Steering work.

When using the Auto Calibration, the cutting width of the plow is automatically adjusted so that the tractor will move neatly on the line in both working directions and the plow will plow the same width in both directions. The Autocalibration plow control consists of 1 button which must be pressed once in both working directions, just before the end of the working pass. When the Autocalibration button is pressed, based on the average width of the plow and the set working width, the "Correct first furrow" will be adjusted for the other working direction. If the soil type or crop changes, the Auto Calibration may have to be performed again.



4. Annexe

4.1. Pin-OUT of the STU – Plough Steering

Table 3 STU B-connector (black)

Pin	Description
1	VCC / PWM
2	ACT Ground
3	ACT Switched
4	ECU Power
5	Input 3 (no function)
6	5V sensor power (option)
7	Plough width sensor signal
8	Plough direction sensor signal (optional)
9	ECU Power (12V sensor power)
10	ECU Ground (sensor ground)
11	ACT Ground
12	VCC / PWM

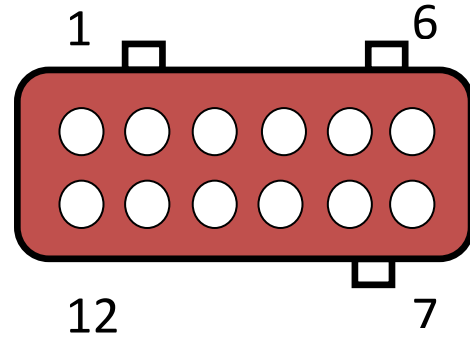
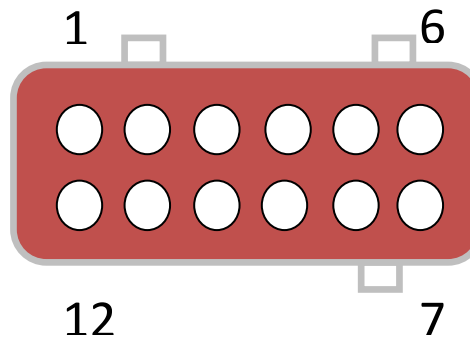

Table 4 STU A connector (grey)

Pin	Description
1	Power Actuator
2	Power Actuator
3	Power ECU
4	N.C.
5	N.C.
6	CAN High
7	CAN Low
8	N.C.
9	N.C.
10	ECU Ground
11	ACT Ground
12	ACT Ground





4.2. Pin-OUT of angle sensor

Table 5 Angle sensor 12V

Pin	Description	Wire colour
1	5V sensor power	-
2	ECU ground	Blue
3	Sensor signal	Black
4	12V sensor power	Brown



4.3. Wiring scheme tractor set ploughs (schematic)

Tractor set for single ploughs:

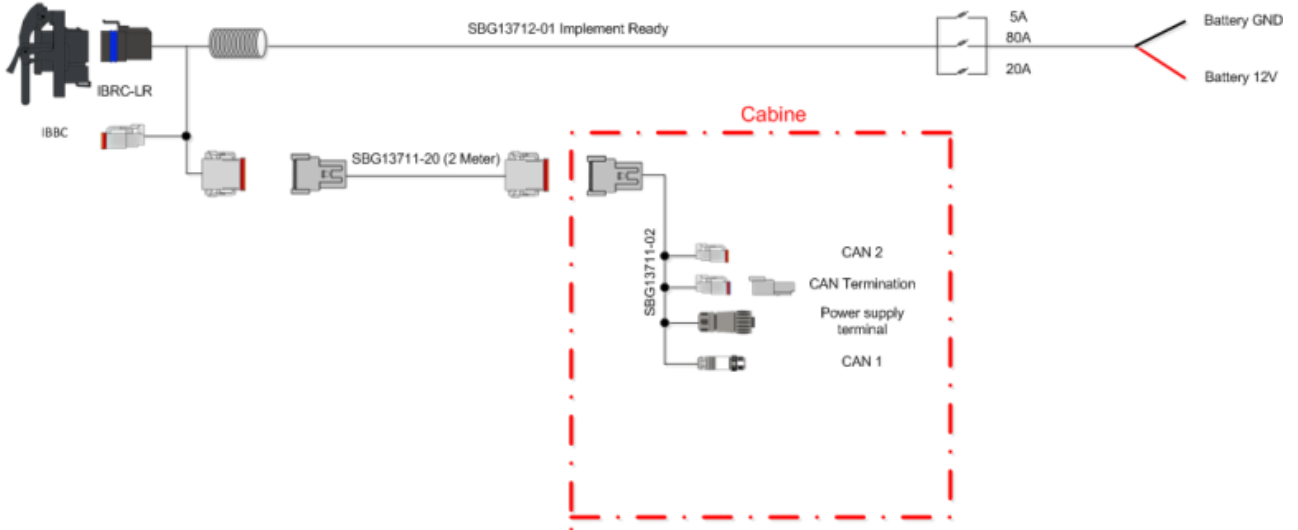

Tractor set for single ploughs with DynamIQ:

