



# INSTALLATION MANUAL

(ENGLISH) (TRANSLATED VERSION)

*SBGuidance Auto*

## **Fendt VarioGuide (Steer Ready)**

016-8000-088EN Rev. A





## Preface

This installation manual is intended for persons responsible for installing a SBGuidance Auto set on a Fendt VarioGuide (GPS Ready) tractor. The manual contains important instructions that should be complied with when commissioning, operating and servicing the SBGuidance system.

This manual has been compiled with the utmost care. SBG Precision Farming assumes no responsibility for any errors or omissions in this document.

Any comments or questions can be sent to [service-eu@ravenind.com](mailto:service-eu@ravenind.com)

**SBG Precision Farming or any of its suppliers will accept no liability for physical or material damage caused whilst using the SBGuidance system.**

The installed SBG system produces less than 70dB (A) noise.

This user guide uses a number of concepts for extra attention to a few things.



### Hint!:

Gives suggestions to make it easier to perform certain tasks



### Pay attention!:

Alerts the user for potential problems.



### Be careful!:

Indicates that the device may possibly be damaged.



### Warning!:

Indicates that there is a danger of personal injury.

### SBG precision farming

Hoornseweg 22

NL-1775 RB Middenmeer

E-Mail: [info@sbg.nl](mailto:info@sbg.nl)

Web: [www.sbg.nl](http://www.sbg.nl)

Phone.: +31 (0)227 54 93 00

## Disclaimer

**Warning!:**

Always switch off the tractor before installing or repairing hydraulic and electrical components of the SBGuidance system.

**Warning!:**

The safety instructions contained in the manuals of the tractor or implements must be complied with at all times.

**Warning!:**

It is strictly prohibited to use the SBGuidance system on public roads.

**Warning!:**

It is strictly prohibited to leave a driving vehicle unattended when the SBGuidance system is switched on. The driver is always responsible for the direction and course of the vehicle.

**Warning!:**

To prevent injury or fire, replace defective fuses only with fuses of the same type and amperage.

**Warning!:**

The SBGuidance the operating system is not able to detect and avoid obstacles. If there is an obstacle in your path, you will always need to take action for it to be avoided.

**Warning!:**

Only allow authorized/qualified persons to operate the system. Authorized/qualified persons are defined as: persons who have read and understood the manual, have been given instructions by a product specialist, and who are both physically and mentally fit and able to operate the system.







**Warning!**

In case of system failure or breakdown switch of the tractor and disconnect the electrical power source to avoid further damage. Contact your dealer for further instructions on how to repair your system.

**Warning!**

The system contains moving parts! Make sure the immediate environment is clear of people before operating the system.



-  **Warning!**  
Always wear personal protective equipment when operating/adjusting/repairing the system outside of the tractor cab.
  
-  **Caution!**  
In order to prevent power surges from occurring, always start the machine first, before initiating the SBGuidance control system.
  
-  **Caution!**  
Only touch the touch-screen with your finger or by using a special touch-screen stylus/pen. Operating the touch-screen with sharp objects may cause permanent damage to the screen.
  
-  **Caution!**  
Always consult your supplier as to which products are best suited first before cleaning the touch-screen with chemicals or alcohol.
  
-  **Please note!**  
If the terminal is not used for a long period, better remove the terminal from the tractor and store in a heated environment. This will extend the life span of the electronic components.
  
-  **Please note!**  
To prevent theft, it is better to not let the terminal and GPS-antenna unattended in the tractor on the field.

## Contents

Preface.....	2
Disclaimer.....	3
Contents .....	5
1 Components overview.....	6
1.1. Overview of electrical components .....	6
1.2. Overview of mechanical components.....	7
2. Tractor kit build up .....	9
3. Mounting harness .....	10
3.1. CAN Implement Ready (IR) harness .....	10
3.2. Mount harness.....	10
4. Mounting GPS- and Radio/UMTS- antenna .....	14
4.1. Mounting standard GPS-antenna bracket .....	14
4.2. Mounting radio-antenna .....	15
4.3. Mounting GSM- en SlingShot GPS-antenna's.....	16
4.4. Mounting GPS and/or GSM (Laird) antenna in Fendt cabinroof.....	17
5. Mounting DynamIQ.....	18
6. Mounting terminal .....	19
7. Calibration steering angle sensor and steering valve (Fendt).....	20
7.1. Calibrate steering angle sensor.....	20
7.2. VarioGuide-steeringvalve (2403) calibration .....	23
8. Software settings (SBGuidance).....	26
8.1. Starting automatic steering (Fendt VarioGuide, standaard) .....	27
8.2. Starting automatic steering (Fendt VarioGuide (Integrated)).....	27



## 1 Components overview

### 1.1. Overview of electrical components

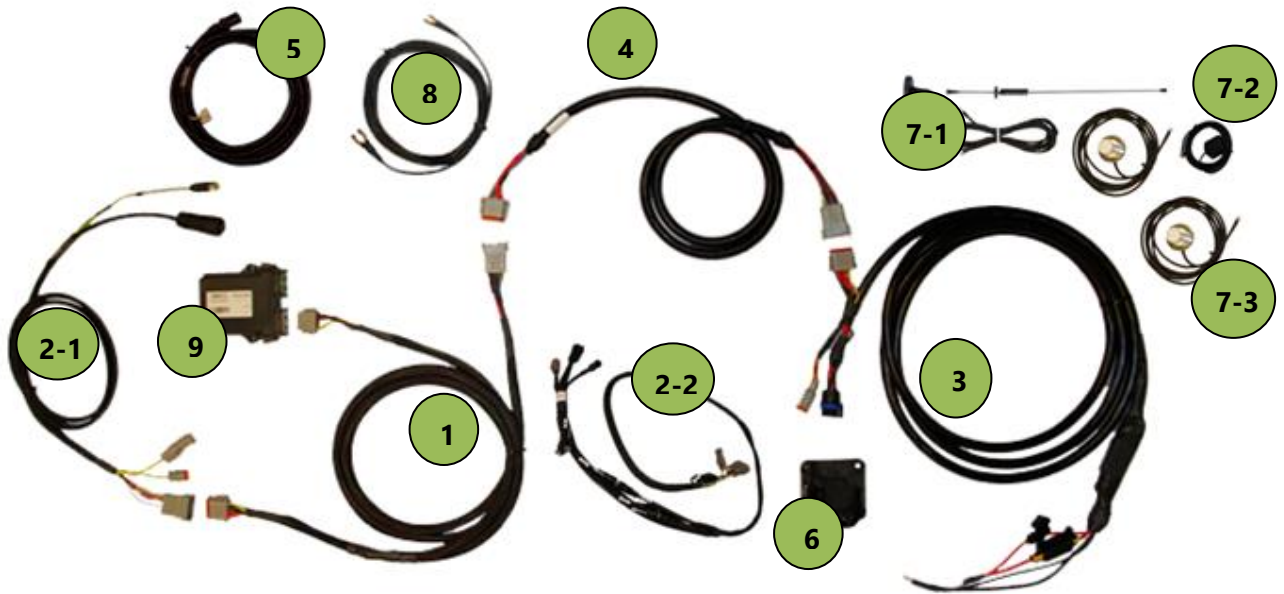

#	Part Number:	Description
1	11158000228	HRNS, IN-CAB, DYNAMIQ
2-1	11158000129	HRNS, IN-CAB, TERMINAL, GEOSTR
2-2	11158000064	HRNS, IN-CAB, TERMINAL, VIPER4
3	11158000141	HRNS, POWER, BASIC
3	11158000060	HRNS, POWER, IMPLEMENT READY
4	11158000214	HRNS, CHASSIS, EXTENSION, 2M
5	11158000225	HRNS, FENDT VARIOGUIDE
6	14084002131	Implement socket (IBBC)
7-1	11178000313	KIT, RADIO ANTENNA TRC, MAGNET
7-2	11218000003	ANTENNA, 4G/3G UMTS LAIRD 3.5M
7-3	10638000015	ANTENNA, PATCH, 4.5M
8	1115800011(0/1/2)	CBL, ANT. 3 / 4.5 / 6M, TNC-N
9	10630173862	DynamIQ ISO - Tractor



## 1.2. Overview of mechanical components

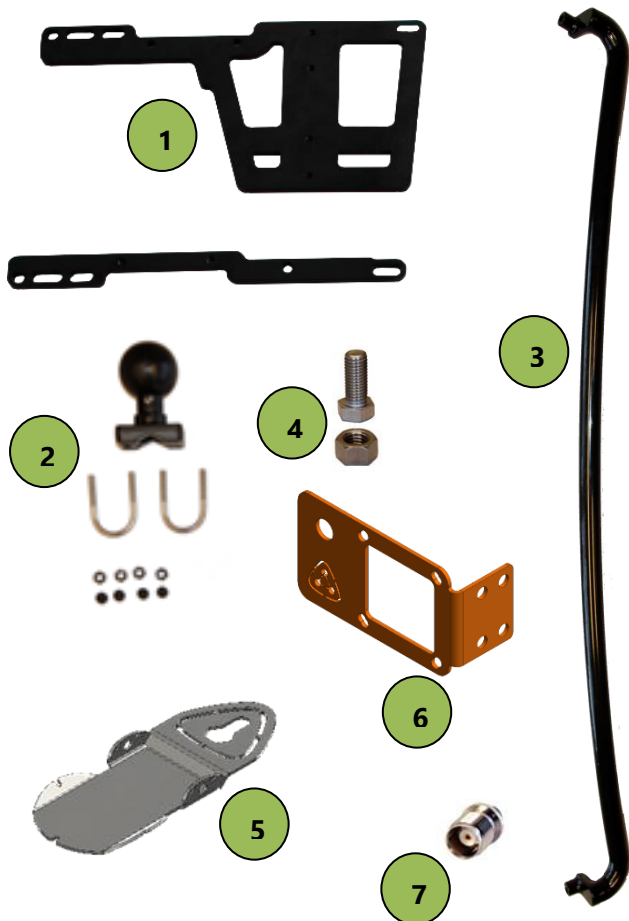

#	Part Number	Description
1	11078000125	BRACKET, DYNAMIQ, V4
2	11030001040	MOUNT, 1" RAIL, RAM D
3	11078000069	BRACKET, RAM, CAB FENDT A POST (Visio plus cabine, 500 en 700-SCR series)
4	11178000311	KIT, BOLT AND NUT UNC, ANTENNA
5	11078000081	BRACKET, GPS/RADIO ANT GENERIC
6	11078000006	BRACKET, IBBC, IR
7	14074001024	TNC Dummy
-	11178000341	KIT, MOUNTING, TRACTOR





## 2. Tractor kit build up

It is recommended to carry out the build up of the tractor in the following order:

1. Mount the entire wire harness from the battery
2. Mount harness on Fendt VarioGuide (R009)
3. Mount GPS antenna and radio/gsm- antenna(s) + cables
4. Mount DynamiQ in cabin
5. Mount Terminal



Figure 1 Overview Fendt VarioGuide components



### 3. Mounting harness

There are two kinds of harnesses available at SBG, a CAN Basic Harness or an Implement Ready.

The Basic harness can only be used for tractor steering. If the tractor is mounted with this harness there is **no** possibility to use the tractor for implement steering (TWIN, plough).

#### 3.1. CAN Implement Ready (IR) harness

The Implement Ready harness ensures that the tractor can be used for tractor and implement steering. Mounting the implement is possible through the IBBC-connector. The harness is mounted from the battery to the IBBC-connector at the back side of the tractor.

#### 3.2. Mount harness

The CAN basic harness and the CAN Implement harness are divided in the following harnesses (ranked in order from the battery):

1. Power harness: This harness comes from the battery and goes to the rear axle along the chassis, wrapped in a hard casing.
2. Extension harness: Extends the Power harness to the In-Cab harness, wrapped in a hard casing.
3. In-Cab harness (DynamIQ): This harness comes from the extension harness and goes inside the cabin, wrapped in a braided sleeve casing. A branch is made to the DynamIQ.
4. Harness in-cab (Terminal): This harness comes from the In-Cab harness (DynamIQ) to the terminal. At a Fendt VarioGuide version the terminating resistor will be removed. After that the Fendt VarioGuide harness will be mounted on that.



Figure 2 CAN-connector Fendt VarioGuide Harness

5. Fendt VarioGuide harness: this harness comes from the In-Cab harness (Terminal) to the Fendt R009 connector (Figure 2). Figure 3 shows the location of the CAN-connection on a 500 and 700 serie. Figure 4 shows the location at a 800 and 900 serie.

**General location:**

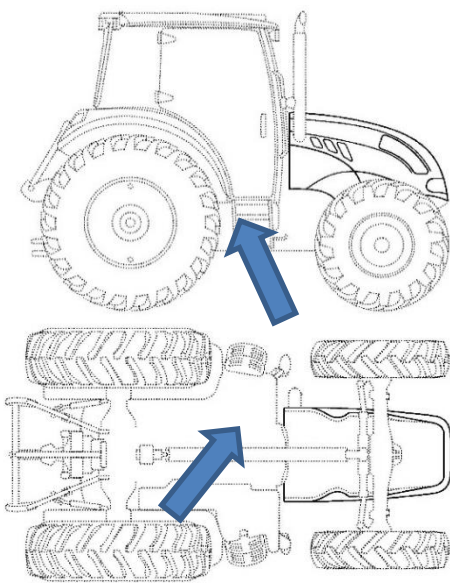

**Fendt 500 SCR:**



**Fendt 700 SCR:**



Figure 3 CAN-connection Fendt VarioGuide 500/700





In Figure 5 is a schematic overview of the SBG CAN harness on a Fendt VarioGuide shown.

Furthermore there are some general instructions for mounting an SBG harness:

- Mount the harness, if there is no battery switch installed, always directly on the battery. That means the positive (red) and the negative (black).
- If a battery switch is used, the harness has to be mounted after the battery switch.
- Mount the terminal harness together with the GPS- and radio/GSM-cable in one jamb.
- Use tie-wraps to mount all the cables vibration and scrape free.

**!** **Pay attention!** Important to mount the harness at all times at last on the battery after mounting all the cables and controllers!

**!** Be sure the cables won't damage during the installation!

**!** Push all connectors until they snap to be sure the connectors are properly connected!

**General location:**

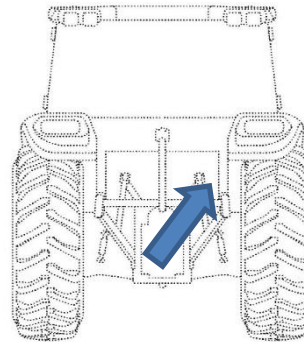

**Fendt 800 S4:**

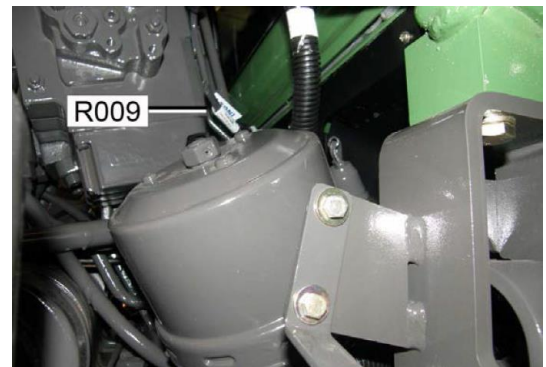

**Fendt 900 S4:**

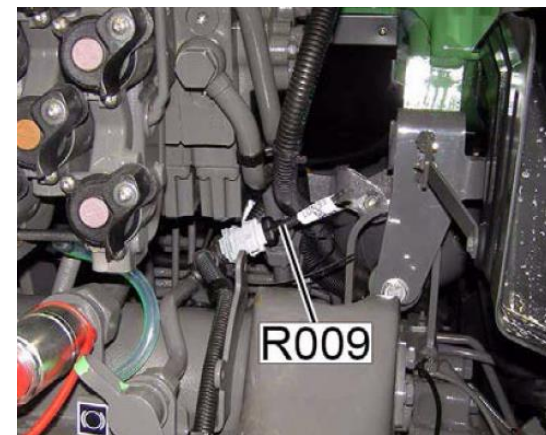

**Fendt 800/900 SCR:**

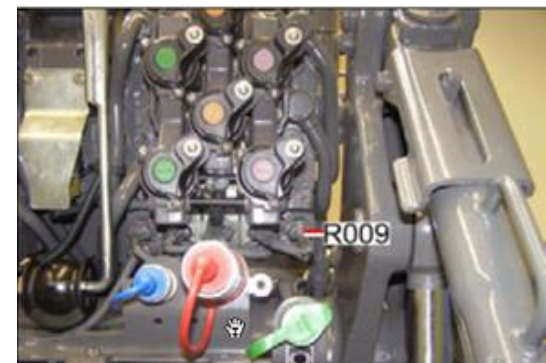

Figure 4 CAN-connection Fendt VarioGuide 800/900

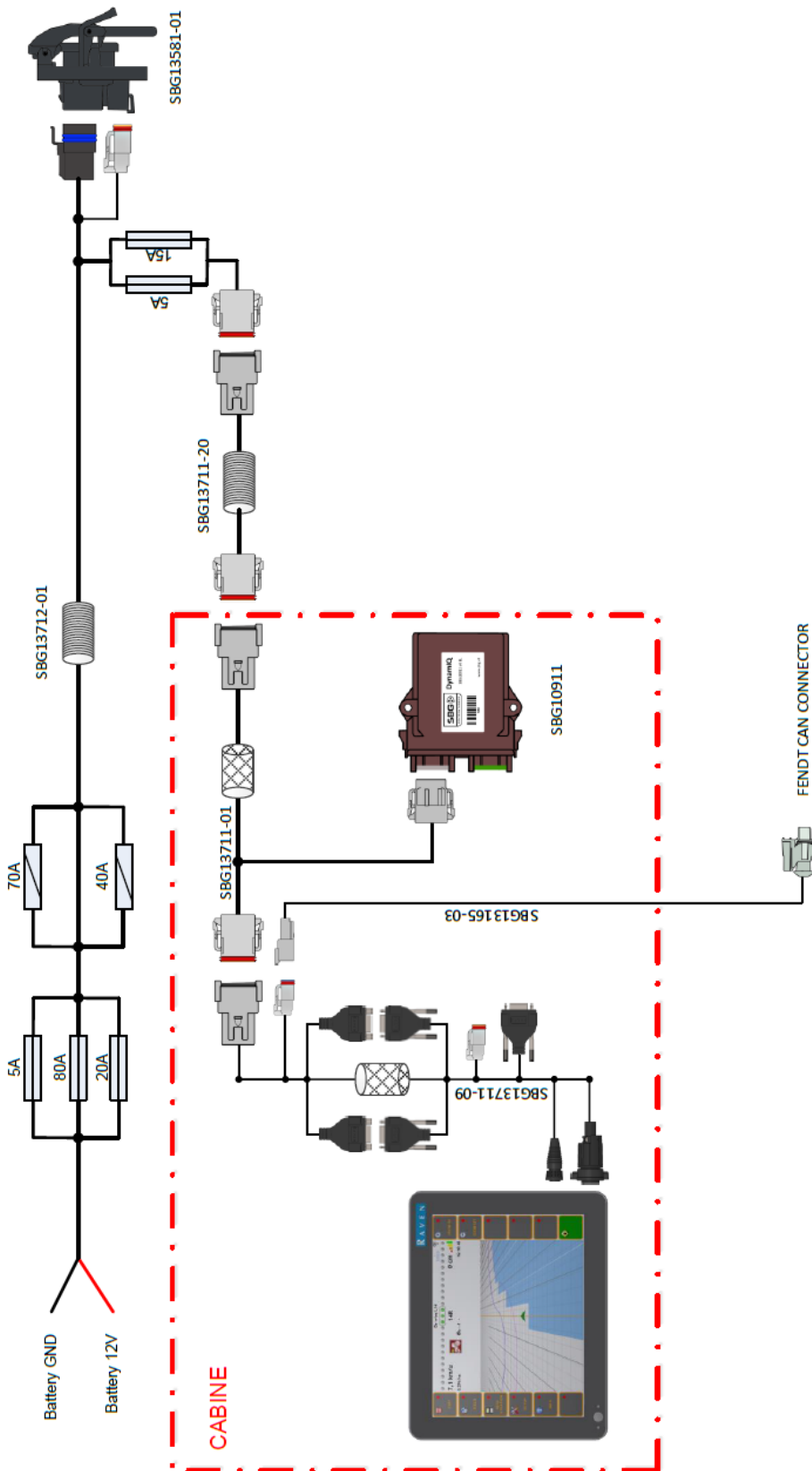

Figure 5 Systemoverview Fendt VarioGuide



## 4. Mounting GPS- and Radio/UMTS- antenna

The GPS antenna can be mounted in two ways on a Fendt VarioGuide tractor:

- Standard installation on the roof (see 4.1 till 4.3)
- Installation in the roof (see 4.4)

### 4.1. Mounting standard GPS-antenna bracket

Figure 6 shows an example of a standard GPS-antenna (with a radio-antenna in this case) mounted on a standard GPS-antenna bracket. A GPS-dummy and a UNC bolt + nut are also mounted. The standard GPS-antenna bracketed can be mounted with double sided tape on the cabinroof.

For mounting a GPS-antenna a few general instructions are applicable:

- Mount the GPS-antenna at least 60 cm in front of the rear axle.
- Mount the GPS-antenna in the middle of the tractor.
- Mount the GPS-antenna on the supplied UNC bolt.
- Mount the TNC-dummy on de GPS-antenna bracket (Figuur 6).
- When a Geostar terminal is used, the side of the biggest connector (N-connector) has to go inside the cabin. At Viper 4 terminals there is no difference between the connectors of the antenna cable.
- Mount the GPS-antennacable properly so it can't be damaged. Hide the cables in the cabin interior.
- Mount the GPS antenna cables in a way water can not flow down into the cabin.



**Figuur 6** Standaard GPS-antenne bracket + UNC bout en moer.



### 4.2. Mounting radio-antenna

Figure 7 shows the standard radio-antenna with magnetic base. Preferably, use the standard antenna. Table 1 shows the components of the standard radio antenna.

Table 1: parts radio antenna

Teken	Omschrijving
1	Radio-antenna
2	Antennacable
3	Connector to terminal
4.1	Magnetic base
4.2	Panel-mount (optional)

The following terms and conditions apply the installation of a radio-antenna:

- Mount the radio-antenna preferably with magnetic base on the standard GPS-antenna bracket. (Figure 6)
- If a steel construction is present on the cabin roof place the radio-antenna on top of the construction in stead of placing it next to the construction.
- Place the magnetic base on a sufficiently large steel surface, at least the size of the standard GPS antenna bracket. Especially with larger distances from the base station, a bigger steel substrate can improve the signal strenght and prevent problems.

Optionally a panelmount antenna (Figure 8) can be used fot mounting. For this antenna are the same terms and conditions applyable as the standard GPS-antenna bracket with magnetic base.



Figure 7 radio-antenna components



Figure 8 Mounted radio-antenna with panel mount



### 4.3. Mounting GSM- en SlingShot GPS-antenna's

At a Fendt VarioGuide a GSM antenna can be mounted inside the roof. For this see paragraph 4.4. This paragraph covers the installation on the roof. (Figure 9)

When a terminal is equipped with a SlingShot, two GSM antennas and a SlingShot GPS antenna (Figure 10) has to be mounted on the roof. The GSM antenna's should preferably be mounted as far away as possible from each other (at least 1.0 meter) for example on the left and right side of the roof on the supplied antenna brackets.

It is important to meet the following conditions at all times:

- Place the two GSM antenna's at least 1.0 meter from each other.
- The GPRS/UMTS-antenna's and the SlingShot GPS patch antenna are equipped with a magnetic base and has to be mounted on top of the cabin roof.
- Antenna's must have a clear view all around.
- Use a metal plate with double sided tape if the GPS-antenna's and GPRS/UMTS antenna will be mounted separately.



Figure 9 Mounting antennes on the roof



Figure 10 SlingShot GPS-antenna

#### 4.4. Mounting GPS and/or GSM (Laird) antenna in Fendt cabinroof

Remove the lining of the roof hatch. (Figure 11)



Figure 11 Roof hatch Fendt VarioGuide

Disconnect the roof hatch (12 x M6 bolts; Figure 12).



Figure 12 Lining removed

Mount the GPS-antenna's like it's shown in Figure 13. Be sure the GPS-antenna is in the middle of the plate.

##### *Corrections through SlingShot;*

Inside the roofplate is space for a GSM-antenna. One of the GSM-antenna's can be placed in here. The other GSM-antenna has to be placed at least 1.0 meter from this antenna. The SlingShot GPS Patch antenna has to be mounted also on the cabin roof. It is also a possibility to place both GSM-antennas on the roof. (Figure 9)

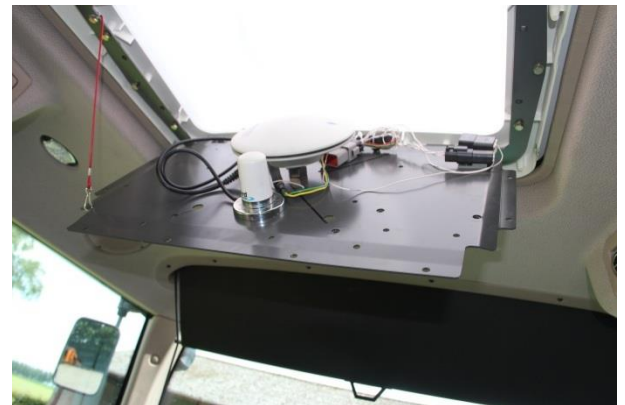

Figure 13 Roof hatch mounted with GPS and Laird antenna

##### *Corrections through Radio*

Place the radio-antenna on the roof and not inside the roof hatch.



## 5. Mounting DynamIQ

The following orders are presented for mounting the DynamIQ:

- Mount the DynamIQ preferably on the right side of the seat. Use the standard DynamIQ mounting plate (Figure 14). Use M8 connecting nuts to extend the bolts of the seat.
- The DynamIQ may only be mounted lying (with the sticker upwards) The connectors may be oriented in 4 directions (0, 90, 180, 270 degrees)
- The standard installation of a DynamIQ is lying (sticker upwards) and with the connectors to the back of the tractor. (like in Figure 14) A different orientation must be set in the software!



Figure 14 DynamIQ on mounting plate



## 6. Mounting terminal

Voor een deugdelijke montage van de terminal in een Fendt wordt de Fendt Terminal bracket (SBG11850-01) gebruikt. Deze wordt gemonteerd aan de A-stijl waarna de RAM-buisbevestiging aan deze stijl kan worden gemonteerd (Figuur 15).

For a proper installation of the terminal in a Fendt, a Fendt Terminal bracket will be used. (SBG11850-01). This bracket is mounted on the A-jamb. The RAM arm can be mounted on this bracket.

The following orders are presented for mounting the Terminal:

- Mount the terminal vibration free with a strong bracket. Multiple brackets are available.
- Hide all te cables in one jamb.
- Be sure the terminal is focused on the driver.
- Be sure the driver has got a clear view after installing the terminal.



**Tip:** fit the terminal in such a way that it doesn't take away the view of the top of the right fender, but also the inside of the front wheel to the ground is still visible.



Figuur 15 Terminal aan ISO bevestiging A-stijl.



## 7. Calibration steering angle sensor and steering valve (Fendt)

The information in this chapter is a copy of a Fendt manual. No rights can be derived from this information.

**Danger:** Be sure there are no persons or objects in the steering area during calibration!

### Work instructions:

- Use the handbrake (be sure the handbrake is activated)
- Start the engine

### 7.1. Calibrate steering angle sensor



Confirm the warning- and error messages on the control panel with ESC.



Press RETURN. The first main menu is shown on the display.



Press multiple times on one of the buttons till symbol (A) starts flashing.



Press RETURN. The second main menu is shown on the display.



Press multiple times on one of the buttons till symbol (A) starts flashing.



Confirm with RETURN

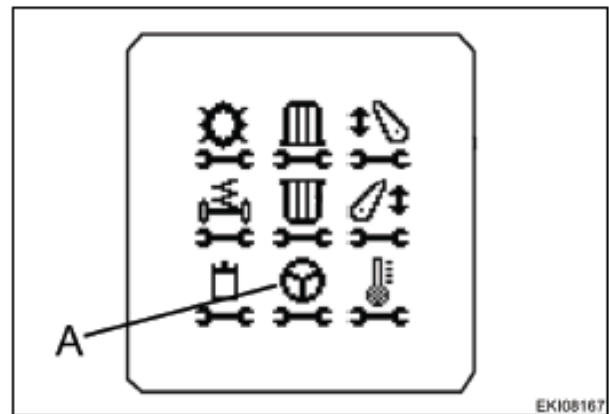
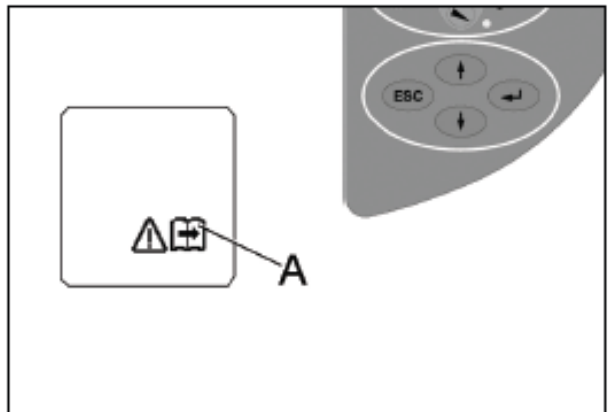
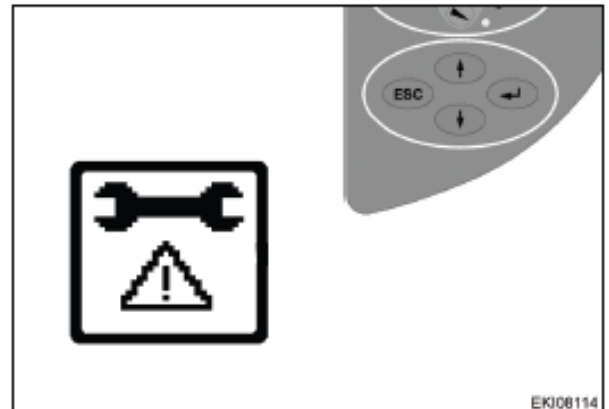



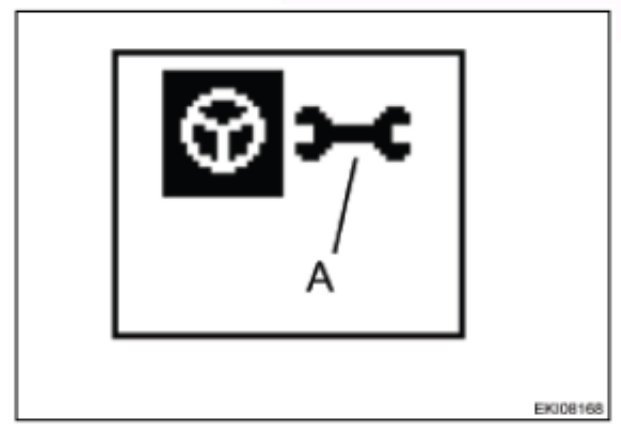

 Press multiple times on one of the buttons till symbol (A) starts flashing.

 Confirm with RETURN



Inputcode **2401**.

 Press multiple times on one of the button till the inputcode is shown.

 Confirm with RETURN



Turn the steeringwheel till the left stop and hold it.

Confirm with RETURN.

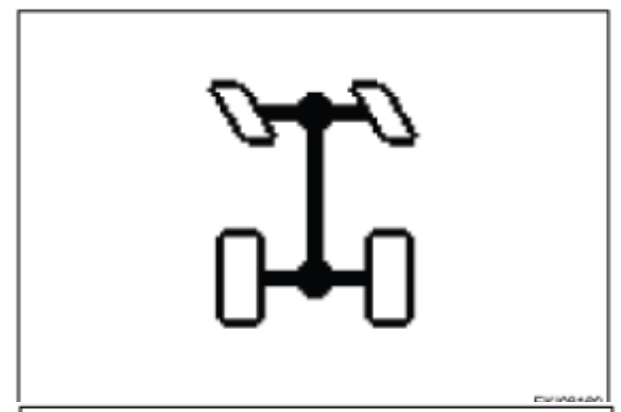

Turn the steeringwheel till the right stop and hold it.

Confirm with RETURN.

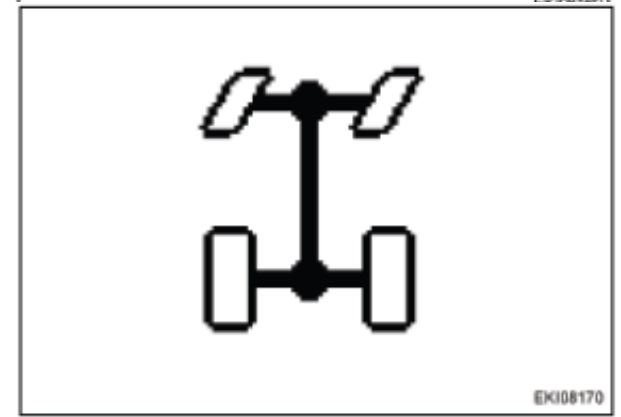



Turn the steering wheel to the middle position and check if the wheels are completely straight.

**Note:** Release the handbrake and drive slowly forwards. Hold the wheels in middle position.



Confirm with RETURN.

When the calibration is finished, the message **O.K.** is shown and the new sensor settings will be saved.

**Note:** The settings will only be saved if the ignition key is in "0" position. Shut down the tractor and wait for at least 30 seconds before the tractor will be started again.

Als verkeerde waarden worden vastgesteld of aan bepaalde voorwaarden niet wordt voldaan, wordt de melding **ERROR** weergegeven.

If incorrect values are established or certain conditions aren't met, an ERROR message is displayed.

**2401** = calibrationcode

**FXX** = errorscode

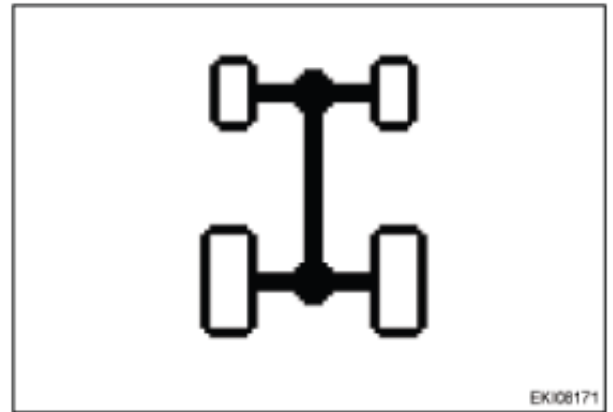

## 7.2. VarioGuide-steeringvalve (2403) calibration

**Danger:** Be sure there are no persons or objects in the steering area during calibration! The front wheels can steer automatic and without warning during calibration.

**Opmerking:** During the calibration the free range of the valve will be determined

### Note the following:

- Do not leave the driver seat
- Start the engine
- Tractor is stationary
- Front wheels are in middle position
- Do not turn the steering wheel

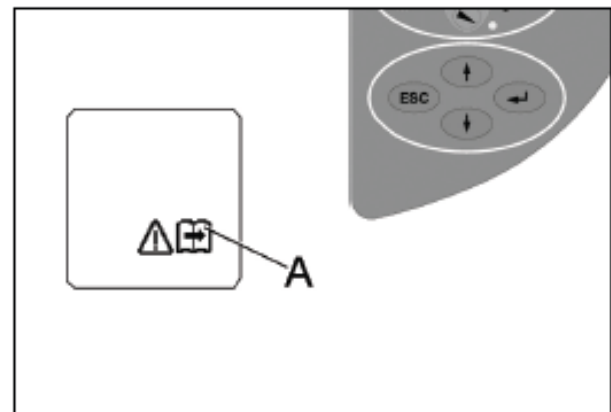
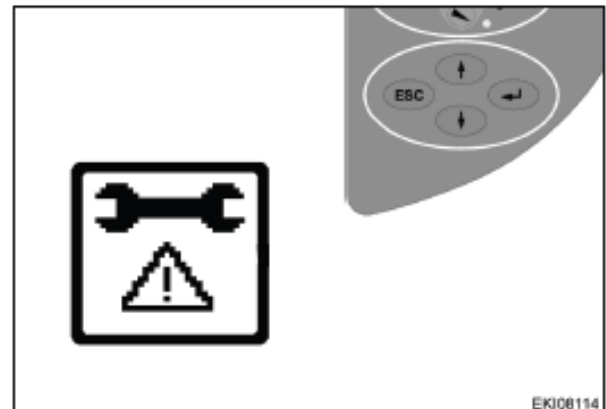

Confirm the warning- and error messages on the control panel with ESC.









Press RETURN. The first main menu is shown on the display.







Press multiple times on one of the buttons till symbol (A) starts flashing

-  Press RETURN. The second main menu is shown on the display..
-  Press multiple times on one of the buttons till symbol (A) starts flashing
-  Press multiple times on one of the buttons till symbol (A) starts flashing
-  Confirm with RETURN.
-  Press multiple times on one of the buttons till symbol (A) starts flashing
-  Press multiple times on one of the buttons till symbol (A) starts flashing
-  Bevestig met RETURN.

Inputcode **2403**.

-  Press multiple times on one of the buttons till the inputcode is shown.
-  Press multiple times on one of the buttons till the inputcode is shown.
-  Confirm with RETURN.

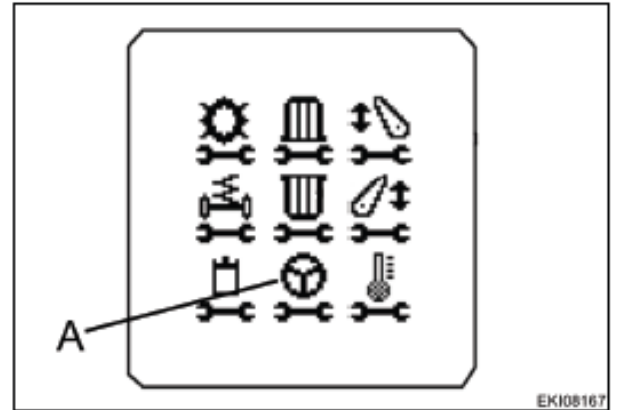

EKI08167

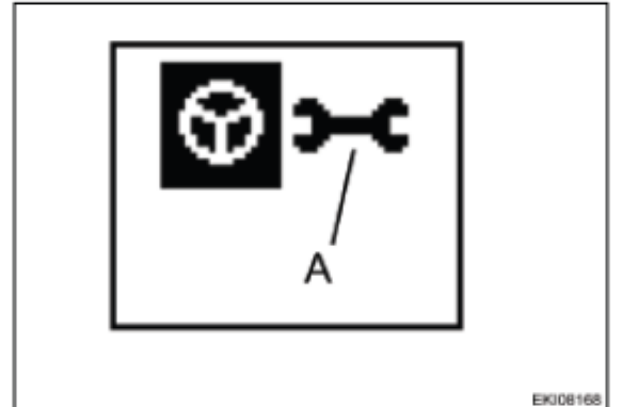

EKI08168



EKI07829

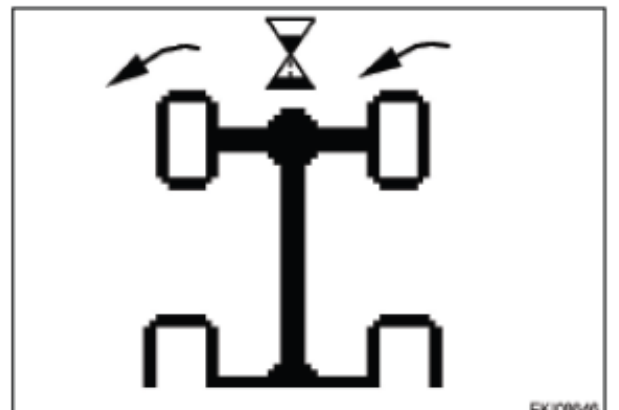

EKI08246

The next image is shown.

**Note:**

- The calibration is automatic (about 5 minutes maximum).
- Do not turn the steering wheel
- Do not leave the driver seat

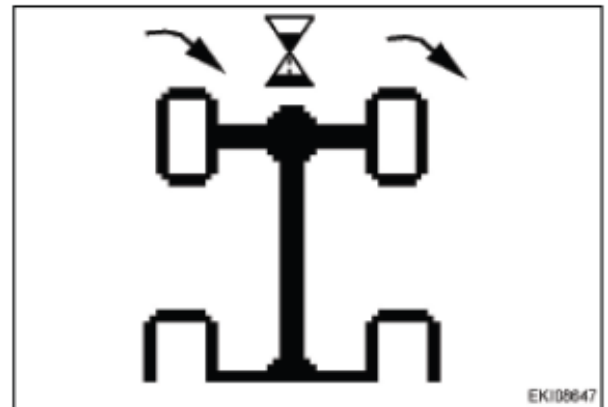

The next image is shown

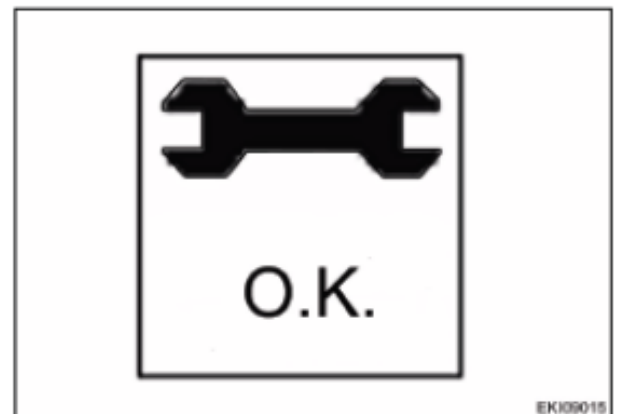

When the calibration is finished, the message **O.K.** is shown and the new sensor settings will be saved.

**Note:** The settings will only be saved if the ignition key is in "0" position. Shut down the tractor and wait for at least 30 seconds before the tractor will be started again.

Als verkeerde waarden worden vastgesteld of aan bepaalde voorwaarden niet wordt voldaan, wordt de melding **ERROR** weergegeven.



If incorrect values are established or certain conditions aren't met, an ERROR message is displayed.

**2401** = calibrationcode

**FXX** = errorscode



## 8. Software settings (SBGuidance)

Create a new machine profile and add it in the Loader with an obvious name.



**Important:** Follow the instructions of the Configuration manual – SBGuidance Auto CAN for configuration SBGuidance Configurator, creating profiles and calibrating the DynamIQ

Select *Fendt VarioGuide* or *Fendt VarioGuide (Integrated)* (Figure 16) at Steering Controller in the ISOBUS tab.

If *Fendt VarioGuide* is selected, the user can start the automatic steering with the GO button on the terminal (standard)

If *Fendt VarioGuide (Integrated)* is selected it's possible to start the automatic steering with the Teach-In buttons (GO/END) of the Fendt-joystick.



**Pay attention:** If the Fendt-joystick is used for starting the automatic steering it's no longer possible to start the automatic steering on the SBGuidance terminal.

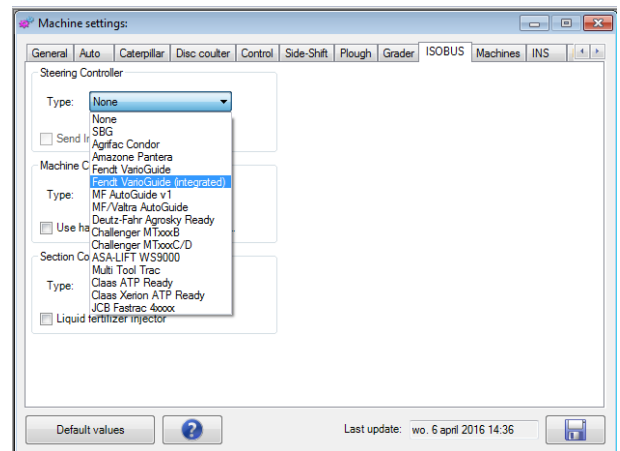

**Figure 16 Steering Controller**



### 8.1. Starting automatic steering (Fendt VarioGuide, standard)

After starting the SBGuidance software the automatic steering on the Fendt tractor has to be switched on before the automatic steering can be started. To do this press the two white buttons (first the right one, then the left one) with the symbol of a steering wheel. The buttons are in the Fendt console. (Figure 17)



Figure 17 Console Fendt

After this the GO button on the SBG / Raven terminal can be switched on and the automatic steering starts.

The activation of the two white buttons in the Fendt console is only necessary if SBGuidance is restarted (again).

### 8.2. Starting automatic steering (Fendt VarioGuide Integrated)

**i** **Pay attention;** the integrated function is not available if Fendt software version 7.81 or higher is installed on the tractor.

After starting the SBGuidance software the automatic steering on the Fendt tractor has to be switched on before the automatic steering can be started. To do this press the right white button (with a steering wheel symbol). After this button is activated the automatic steering can be switched on and off with the left white button.

**i** **Pay attention;** in contrast to the standard configuration this steering becomes directly active after the button is switched on.

The starting of the automatic steering can now be linked to the GO/END buttons on the joystick.

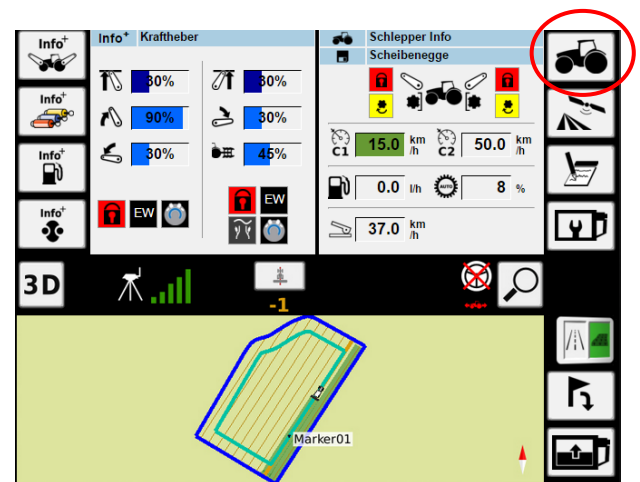

Figure 18 Console Fendt



- Press the tractor icon (Figure 18)

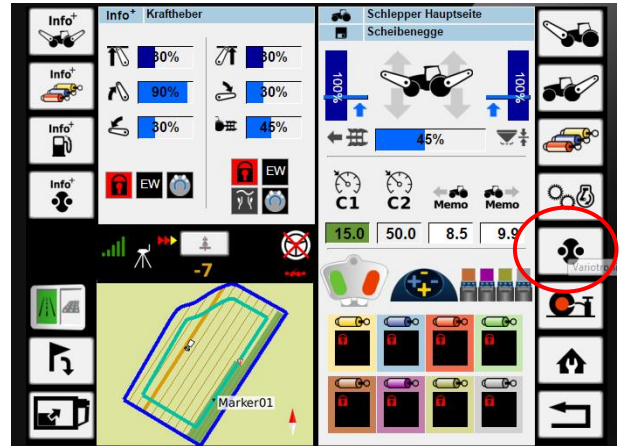

Figure 19 Console Fendt

- Press the button with the 'GO/END' icon (Teach-In) (Figure 19)

- Unblock the Teach-in function by pressing the block/deblock button.

- Press the 'Edit Offline' button (Figure 20)

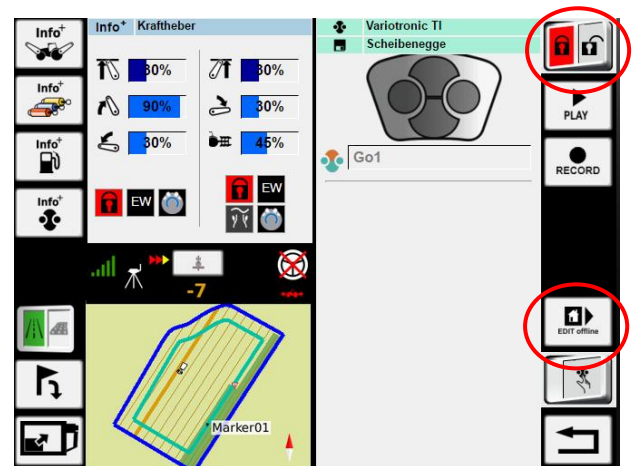

Figure 20 Console Fendt

- Press the GO/END button that is desired for switching the automatic steering on/off.
- Select the actions who will be linked to the selected button.

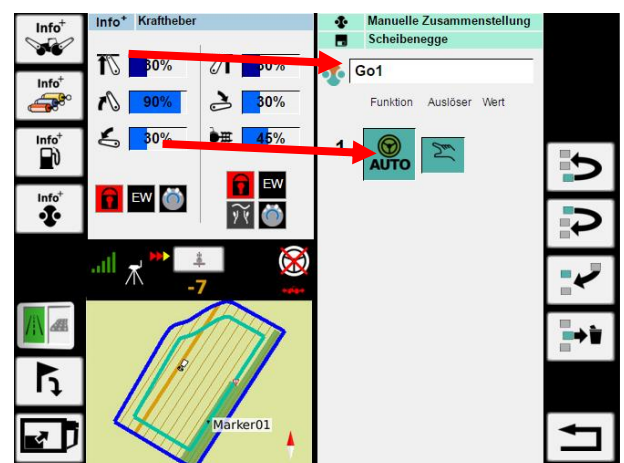

Figure 21 Console Fendt

The screen shows, like Figure 21, which actions are linked with the selected buttons.