



INSTALLATION MANUAL

SBGuidance Side-Shift

Side-Shift and Drawbar steering

(Original Instructions)







Table of contents

Preface	5
Disclaimer	6
1. Instructions for installing SBGuidance Side-Shift.....	7
1.1. Overview of basic components for the Side-Shift/Drawbar steering	9
1.2. Overview Side-Shift adapter frame and cylinders (optional)	10
1.3. Assembled Side-Shift frame	11
2. Installation basic components.....	12
2.1. Installing the Side-Shift cylinder.....	12
2.2. Checking the hydraulic manifold	13
2.3. Mounting the hydraulic manifold	13
2.4. Mounting of the Steering Controller	14
2.5. Mounting of the angle sensor	14
2.5.1. Mounting of the angle sensor in the bracket.....	15
2.5.2. Side-Shift steering.....	15
2.5.3. Drawbar steering.....	16
2.6. Mounting of the GPS-Antenna.....	17
2.7. Mounting of the DynamIQ.....	17
2.8. Placing and connecting cabling	18
2.9. CAN implement harness (schematics).....	19
3. Configuration and calibration	20
3.1. Configuration CAN-Tool.....	20
3.2. Determine control speeds.....	21
3.2.1. Proportional steering	22



- 3.2.2. Pulse steering24
- 3.3. Calibrating angle sensor25
- 3.4. Configuration PID controllers26
- 3.5. Configurator set-up27
- 3.6. Calibrating DynamIQ27
- 3.7. Checking centre adjustments.....28
- 4. Annex29
 - 4.1. Pin-out STU connectors.....29
 - 4.2. Pin-out Angle sensor30



Preface

This configuration manual is intended for persons responsible for installing an SBGuidance Side-Shift set. The manual contains important instructions that should be complied with when commissioning, operating and servicing the SBGuidance system.

This manual has been compiled with the utmost care. SBG Precision Farming assumes no responsibility for any errors or omissions in this document.

Any comments or questions can be sent to service-eu@ravenind.com.

SBG Precision Farming nor any of its suppliers will accept no liability for physical or material damage caused whilst using the SBGuidance system.

The installed SBG systems produces less than 70 dBA.

SBG precision farming

Hoornseweg 22

NL-1775 RB Middenmeer

E-Mail: info@sbg.nl

Web: www.sbg.nl

Phone.: +31 (0)227 54 93 00

Disclaimer



Warning!:

Always switch off the tractor before installing or repairing hydraulic and electrical components of the SBGuidance system.



Warning!

The system contains moving parts! Make sure the immediate environment is clear of people before operating the system



Warning!

Always wear personal protective equipment when operating/adjusting/repairing the system outside of the tractor cabin.



Warning!

In case of system failure or breakdown switch of the tractor and disconnect the electrical power source to avoid further damage. Contact SBG for further instructions on how to repair your system.



Warning!:

The safety instructions contained in the manuals of the tractor or implements must be complied with at all times.



Warning!:

It is strictly prohibited to use the SBGuidance system on public roads.



Warning!:

It is strictly prohibited to leave a driving vehicle unattended whilst the SBGuidance steering system is switched on. The driver is always responsible for the direction and course of the vehicle.



Warning!:

In order to prevent personal injury or fire, defective or blown fuses may only be replaced by fuses of the same type and amperage.



Warning!:

The SBGuidance steering system is not capable of identifying and avoiding obstacles. Any obstacles along the driving path must be avoided by the driver.



- !** **Warning!:**
Only allow authorized/qualified persons to operate the system. Authorized/qualified persons include: Persons who have read and understood the operating manual and who are both physically and mentally fit to operate the system.
- !** **Caution!:**
Always start the machine first, before activating the SBGuidance steering system in order to prevent the occurrence of a peak voltage.
- !** **Caution!:**
Only touch the touch-screen with your finger or by using a special touch-screen stylus/pen. Operating the touch-screen with sharp objects may cause permanent damage to the screen.
- !** **Caution!:**
Only clean the screen using a damp cloth. Never use caustic or other aggressive substances.
- i** **Please note!**
If the terminal is not used for a long period, better remove the terminal from the tractor and store in a heated environment. This will extend the life span of the electronic components.
- i** **Please note!**
To prevent theft, it is better to not let the terminal and GPS-antenna unattended in the tractor on the field.

1. Instructions for installing SBGuidance Side-Shift

This manual is a general guide and is not intended for any specific brand or type. This section provides an overview of all basic components. The exact content of the Side-Shift steering set depends on brand and type of machine.

All necessary parts are supplied, including this manual. Verify that all items listed on the packing list are actually present.



1.1. Overview of basic components for the Side-Shift/Drawbar steering

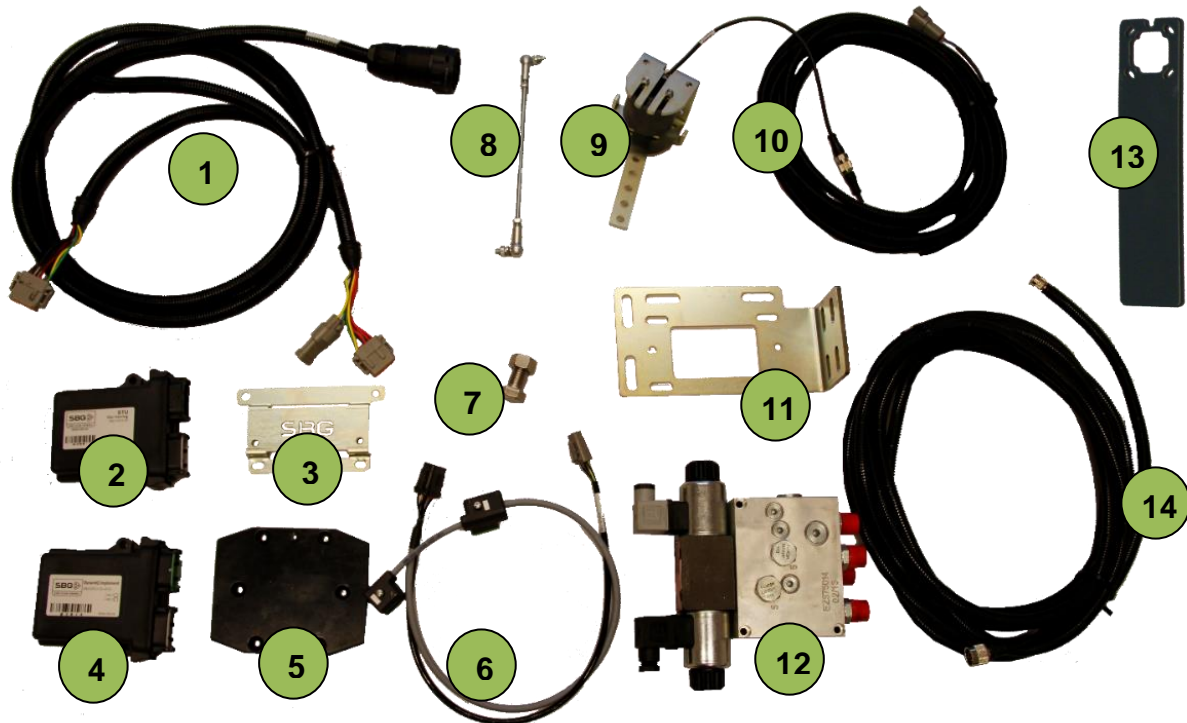

Sign	Part-number	Description
1	SBG13713-01	Harness Implement 4,0 m – TWIN
2	SBG10919-07	STU – Side-Shift Steering
3	SBG12705-05	STU bracket
4	SBG10911-01	DynamiQ Implement
5	SBG12700	DynamiQ universal bracket
6	SBG13710-07	Hydraulic harness STU
7	SBG10002	GPS-antenna bolt
8	SBG10095-01, SBG10090	Thread with junction balls
9	SBG11901-06	Angle Sensor 12V 90° in bracket
10	SBG11901-08	Angle Sensor Cable (5,0 m)
11	SBG11823-01	Manifold bracket
12	SBG10690	Hydraulic manifold implement
13	SBG11630	Angle Sensor bracket straight
14	SBG10048	GPS-antenna Lead (6,0 m)

1.2. Overview Side-Shift adapter frame and cylinders (optional)

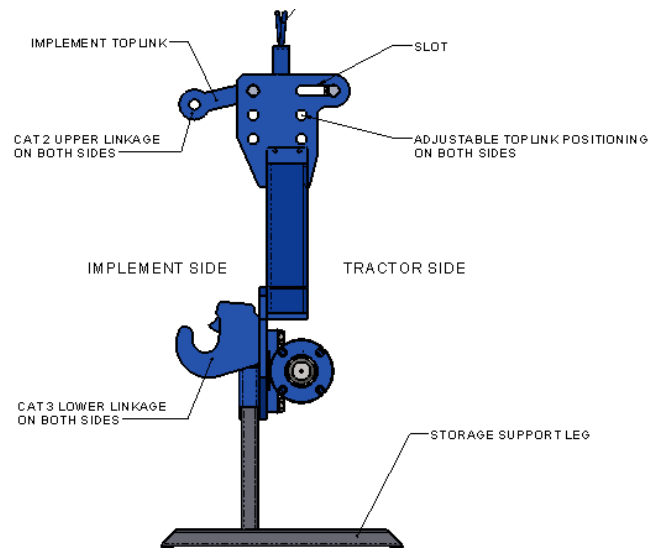
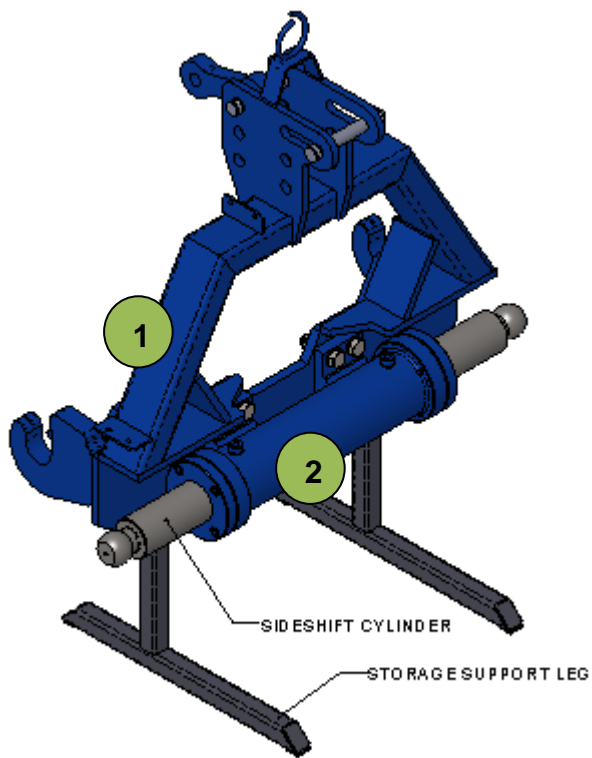

Sign	Part-number	Description
1	SBG12400	Side-Shift frame (excl. cylinder)
2a	SBG10650	Side-Shift cylinder Cat 2 2000 kg
2b	SBG10651-01	Side-Shift cylinder Cat 3 4500 kg
2c	SBG10652	Side-Shift cylinder Cat 3 8000 kg

1.3. Assembled Side-Shift frame

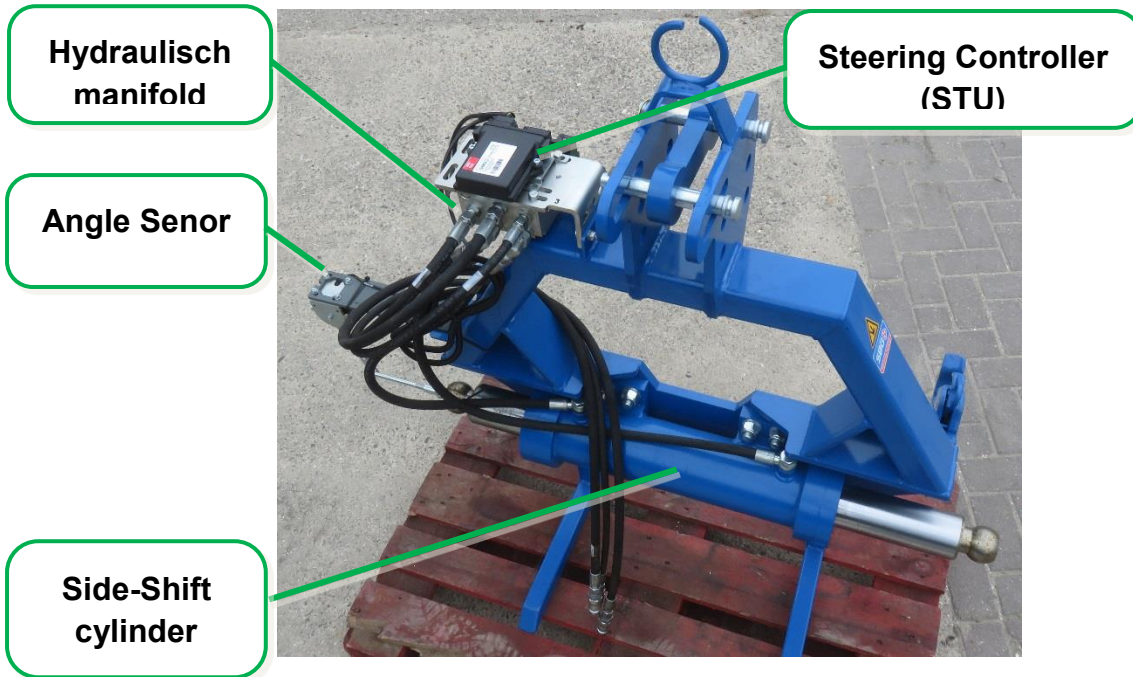

- i** When using the Side-Shift adapter frame it's advised to place both GPS-antenna and DynamIQ on the attached implement. Keep the distance to the cylinder as short as possible! In case of frequent implement changes the DynamIQ could be placed on the adapter frame.
- i** Specific installation and safety instructions can be found in the Installation Manual – Side-Shift Implement Frame.

2. Installation basic components

It's advised to install the Side-Shift or drawbar steering in the order as listed below:

1. Installing the Side-Shift cylinder (if necessary).
2. Checking the hydraulic manifold.
3. Mounting of the manifold and connecting the hydraulic hoses.
4. Mounting the Steering Controller.
5. Mounting the angle sensor.
6. Mounting the GPS-antenna.
7. Mounting the DynamIQ.
8. Placing and connecting cabling

2.1. Installing the Side-Shift cylinder

Start with mounting the hydraulic cylinder. The cylinder is available in three weight categories 2; 4,5 and 8 ton. It's possible to either mount directly to the implement or to use the adapter frame. In the adapter frame it's possible to mount different types of mounted implements.

When mounting the cylinder directly to the existing implement it's important to place the cylinder the same way as the original linkage points, this prevents the machine from getting further behind the tractor.

 *Make sure that at the limits of the linkage (up and down) and at the limits of the Side Shift cylinder (left and right), the PTO shaft can move free without hitting the frame.*

 *Make sure the Side-Shift cylinder is in its center position before lifting the implement.*



2.2. Checking the hydraulic manifold

The hydraulic implement manifold is suited for use in both Load-Sense (L.S.) and Open Center (O.C.) hydraulic systems. Depending on the type of installation a different type of selector plug must be installed in the manifold (Table 1, Figure 2).

Check the type of the selector plug (Figure 1) before mounting the manifold.

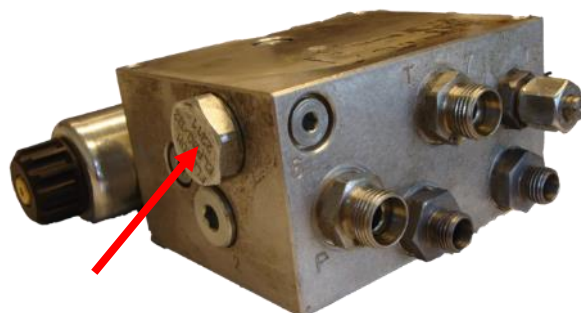

Figure 1 Selector plug

Table 1 Selector plug manifold

Type of hydraulics	Selector plug
Load Sense	SBG10810 Blind plug without imprint
Open Center	SBG10820 ELP30/D2

If the manifold is connected to the auxiliary hydraulic connectors at the rear of the tractor, the manifold must be configured in Open Center mode. The LS connector must be capped.

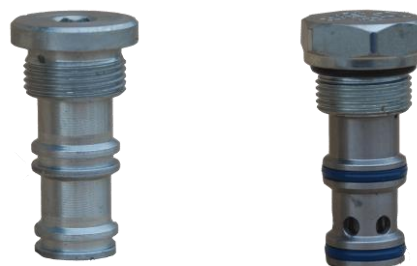

Figure 2 Selector plug. Left: L.S. Right O.C.

! *When Open Center is chosen, other selector plugs need to be used in the manifold than when Load Sense is used!*

2.3. Mounting the hydraulic manifold

For mounting purposes the manifold is equipped with 3x M8 holes with internal thread. Attach the manifold to the supplied manifold bracket (Figure 3).

Place the manifold in such a way that the hydraulic hoses from the manifold can be easily directed towards the tractor and the control cylinder. Ensure that the DIN connectors on the valve can be connected after fitting the manifold. Connect the control cylinder to A and B of the manifold.



Figure 3 Manifold and STU mounted on Side-Shift frame

Load Sense

Connect the pressure line to **P**, the return line to **T** and the sensor line to **LS** on the manifold. Use the Load Sense (L.S.) connections of the tractor.

Open Center

Connect the pressure line to **P** and the return line to **T** on the manifold. Use the external hydraulic valve of the tractor.



Figure 4 Manual control hydraulic valve

i The Side-Shift cylinder can also be manually steered by pressing the pin on the proportional valve (Figure 4)

2.4. Mounting of the Steering Controller

The Steering Controller (STU – Side-Shift steering) can be mounted to the manifold with the aid of an STU bracket (Figure 3). Mounting the controller to the frame of the implement is also an option.

It is recommended to mount the STU flat or with the connectors directed downwards, to prevent water collecting on the connectors.

2.5. Mounting of the angle sensor

The angle sensor measures the exact position of the Side-Shift cylinder or drawbar. When using Side-Shift steering, an angle sensor is needed to show the current position of the cylinder in the software and to use the “Auto-Center” functionality.

i In a Side-Shift steering kit an angle sensor is delivered in an angle sensor bracket (Figure 5) by standard.

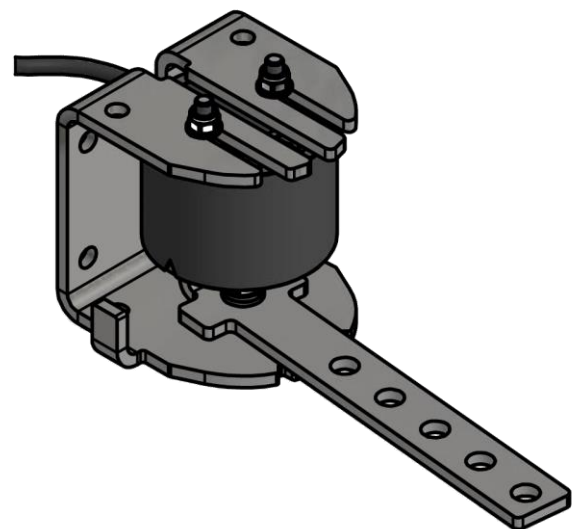

Figure 5 Angle sensor mounted in bracket



2.5.1. Mounting of the angle sensor in the bracket

Use the following description to mount the angle sensor in the bracket (Figure 6):

1. The sensor consists of two parts, both need to be mounted with M5 bolts. The smallest piece (little disc) needs to be mounted to the “arm”-bracket and the biggest piece (sensor housing) needs to be mounted to the “U”-shaped bracket.
2. The sensor bracket consists of two parts. Mount those parts in the following order: M6 bolt, washer, “U”-shaped bracket, fender washer, “arm”-bracket, washer, split lock washer and nylon insert lock nut.
3. Fasten the lock nut at its fullest then loosen a little.



Before mounting check if the sensor disc can move freely in the sensor housing when turning the sensor arm.

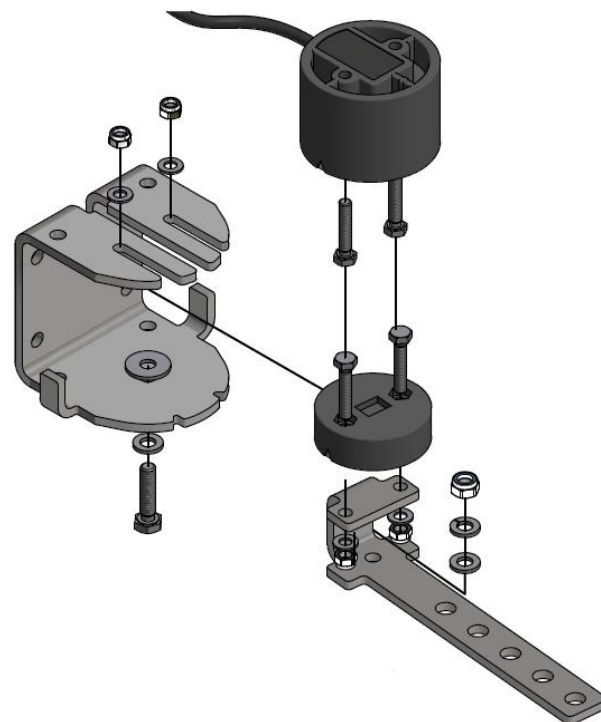

Figure 6 overview of angle sensor bracket

2.5.2. Side-Shift steering

When using side-shift steering the angle sensor needs to be connected to the side-shift cylinder. At the end of the cylinder a hole with internal thread is present for easy mounting of the angle sensor connection.

The installation needs to be done in such a way that the position of the angle sensor is in line with the side-shift cylinder and the threaded rod is an extension between the cylinder and the angle sensor arm (Figure 7).



Figure 7 Mounting angle sensor Side-shift steering top view

i In a Side-Shift steering kit an angle sensor is delivered in an angle sensor bracket by standard.

Keep in mind that the max angle of the sensor is around 90°. A good reference position is to have the 8th hole in the sensor arm on the same line as the side-shift cylinder (Figure 8). Cut the threaded rod between the ball joints at the desired length, make sure the cylinder is in its middle position and the sensor arm is facing straight downwards when doing so. The center voltage of the angle sensor will now correspond with the center position of the cylinder.

i The range of measurement of the angle sensor lies between 0,5 and 4,5V.

When using the Side-Shift adapter frame a metal strip is placed for installing the angle sensor bracket (Figure 9).

2.5.3. Drawbar steering

When using a drawbar steering the angle sensor needs to be placed near the articulation joint of the drawbar (Figure 10). Determine the position of the angle sensor bracket by moving the drawbar in its outer left and right position. The angle that the arm of the angle sensor bracket makes in outer left and right position should be more or less the same. Keep in mind that the maximum angle of the sensor is around 90°. It's desirable that the angle sensor makes a total angle of 90° between the outer left and outer right position. However, the system will also function when the total angle is smaller.

! The sensor housing needs to be mounted facing downwards so moisture and filth cannot get trapped in the sensor.



Figure 8 Mounting angle sensor Side-Shift steering side view



Figure 9 Mounting angle sensor Side-shift adapter frame



Figure 10 Mounting angle sensor drawbar steering



2.6. Mounting of the GPS-Antenna

The most suited antenna position depends on the implement that's being used.

When using mounted implements with Side-Shift steering it's advised to mount the antenna as close to the cylinder as possible (Figure 11). When using trailed machines with drawbar steering it's advised to mount the antenna as close to the articulation joint of the drawbar as possible (Figure 12).

It's advised to always try to place the GPS-antenna in the middle of the implement. The GPS-antenna needs to be mounted as low as can be without obstructing the antennas line of sight (an angle of 20° from the horizon). If the cabin roof is the highest point, it isn't necessary to place the GPS-antenna higher than the roof. If distance between roof and antenna increase the height of the GPS-antenna can be decreased.

 *Use a telescopic bracket for mounting the GPS-antenna. In that case, if field conditions don't provide enough satellite reception it is always possible to elongate the bracket to get better satellite signal.*

2.7. Mounting of the DynamiQ

Mount the DynamiQ terrain compensation on a flat surface free from vibrations and preferably with the connectors pointing to the rear (default configuration). A good place to do this would be on the main frame of the machine.



Figure 11 GPS-antenna position on Side-Shift steering

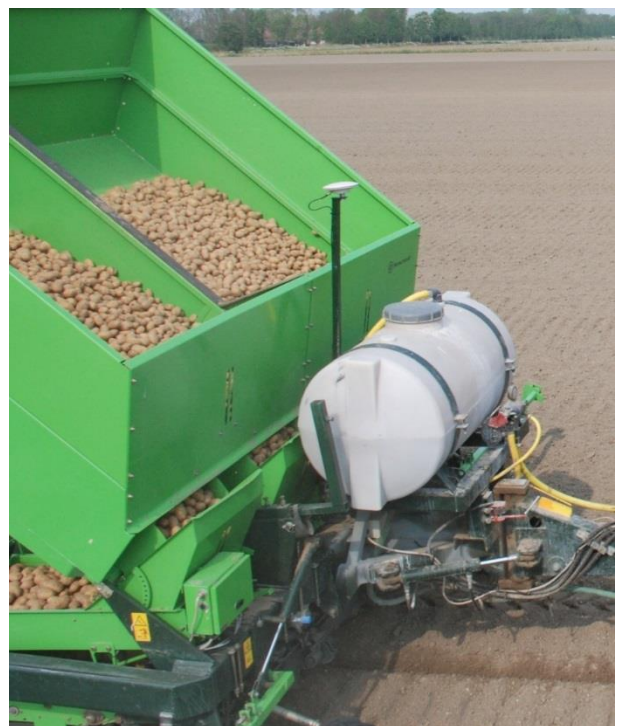

Figure 12 GPS-antenna position on drawbar steering

2.8. Placing and connecting cabling

An Implement-ready wiring harness is required on the tractor for connecting the Side-Shift or drawbar steering. The IBBC connector ensures that connection (Figure 13).

Section 2.9 shows a schematic view of the lead connecting circuit. The CAN implement lead ensures that the STU and DynamIQ are connected to the tractor. In addition, the hydraulic harness needs to be connected to the STU. This hydraulic harness ensures the control of the hydraulic valve and the readout of the angle sensor.

A panel mount antenna connection mounted on the IBBC bracket is optional (Figure 14). An antenna cable/lead can be concealed in the cabin between the terminal and the IBBC bracket.



Figure 13 IBBC bracket with connector

! *Mount the CAN implement lead in such a way that the separate conductors coming from the protective sleeve are directed downwards. This will prevent any penetration of water into the protective sleeve.*

! *Ensure that the leads are not damaged when installed.*

i *Tip: Tie-wrap the leads so that they are attached free from vibration and friction.*

! *Press the connectors firmly into place until they click!*



Figure 14 IBBC bracket with panel mount for antenna connection

2.9. CAN implement harness (schematics)

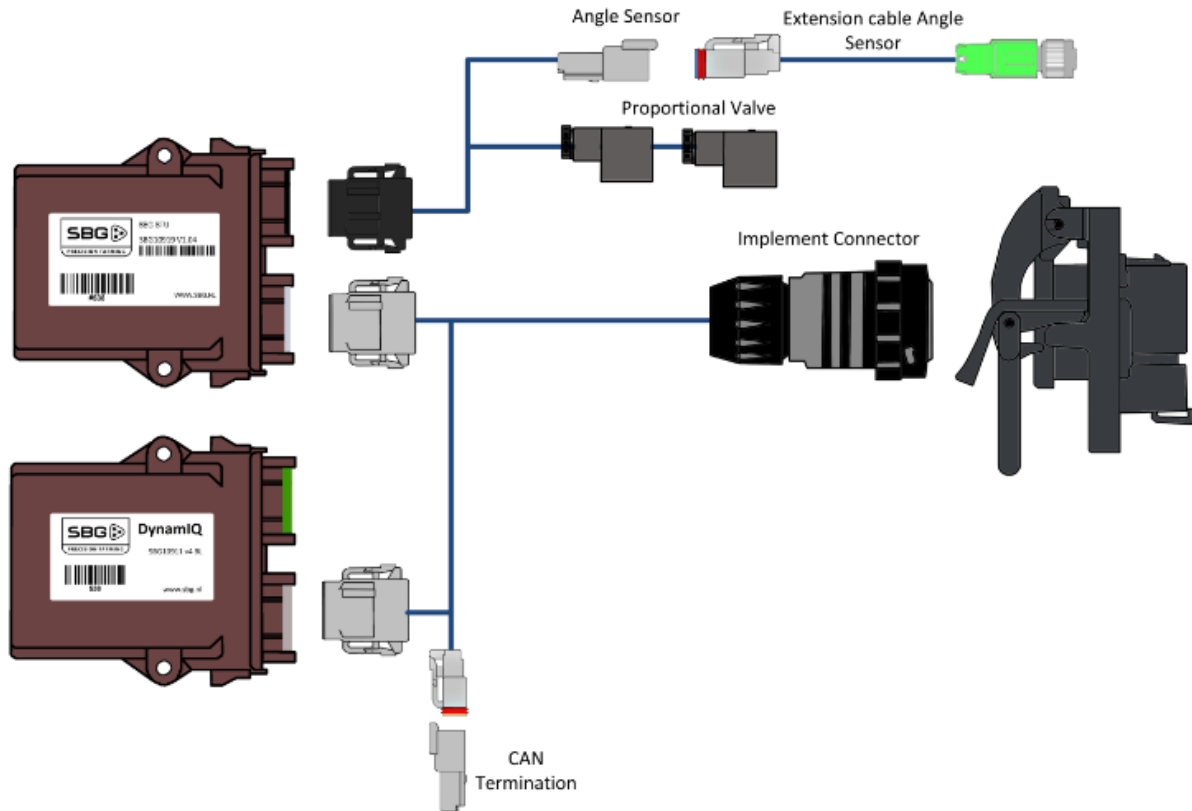



Figure 15 CAN implement harness

3. Configuration and calibration

The following software and firmware versions are required for the set-up, calibration and use of the CAN Side-Shift controller:

- CAN-Tool 1.28 or more recent version.
- Side-Shift steering firmware *STU_Side-Shift_2.0.30* or more recent version
- SBGuidance 3.8.2 or more recent version.

 Check the download page on www.sbg.nl for the most recent software and firmware versions.

 View Configuration manual – CANbus controllers for updating a steering controller.

3.1. Configuration CAN-Tool

Startup the CAN tool. At Hardware, choose manufacturer “**Viper 4**” in case of a Viper4 terminal and “**SBG**” in case of a GeoSTAR terminal and press on *Initialize*.

After initializing the connection with the CAN bus, a bus load must be displayed. Received frames must be in increasing increments. The bus load and received frames are displayed at the bottom of the screen. If this is not the case, check the lead connections.

Go to the tab page MyDevice (Figure 16) and at Pre-selection select “**Navigation Controller (Implement)**”. Then press “*Connect*”.

Go to the tab page MyPartners (Figure 17). At Implement Controller press “*Add*”. This will

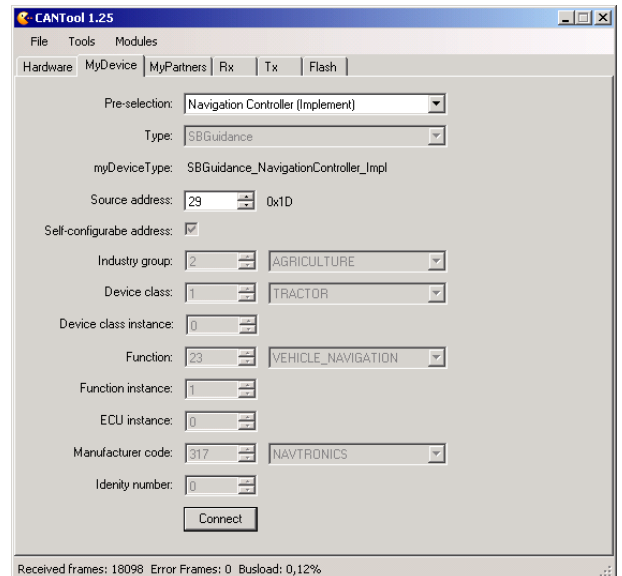

Figure 16 CAN-Tool MyDevice Implement Controller

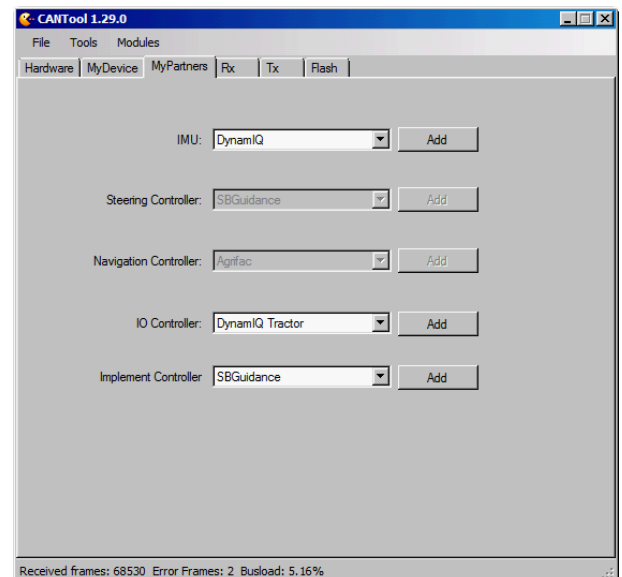

Figure 17 CANTool Mypartners Implement Controller



SBGuidance Side-Shift I Version 1.1 | CAN

open the set-up screen for the CAN Side-Shift steering (Figure 18).

The steering controller is recognized if the status is on *Running*, if an *SW Version* is displayed and the correct type of STU is detected. In addition, a sensor value should be displayed and a yellow line should be visible in the graphic display. The sensor value should change when the steering system is used.

! *Check whether the Steering is recognized before you continue to set up and calibrate the Side-Shift steering.*

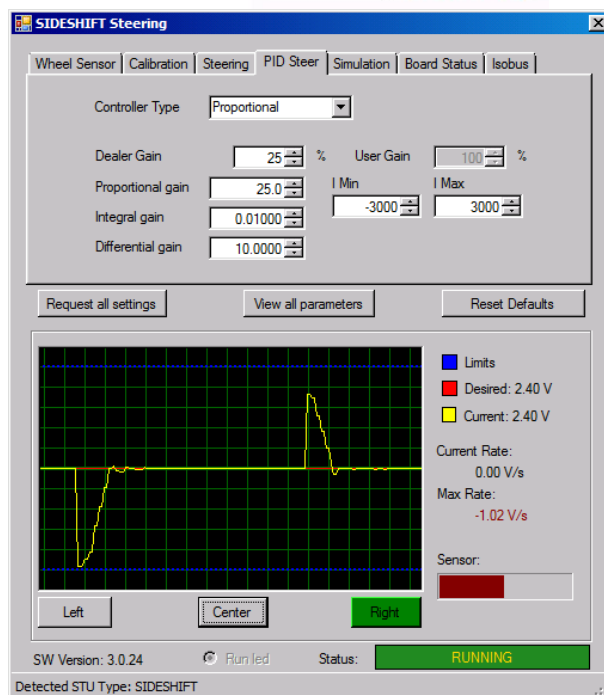

Figure 18 CANTool Side-Shift Steering

3.2. Determine control speeds

By default, the manifold is equipped with a proportional valve (Figure 19). When using Side-shift steering two different types of controls can be selected:

- Proportional controls
- Pulse controls

In most cases the proportional controls will work just fine in combination with a proportional hydraulic valve. In some cases when using heavy machines where GPS-antenna is mounted relatively far behind the Side-Shift cylinder, better performance can be achieved by using the pulse controls.

! *When the manifold is equipped with a on/off hydraulic valve it's only possible to use the pulse controls. See chapter 3.2.2.*

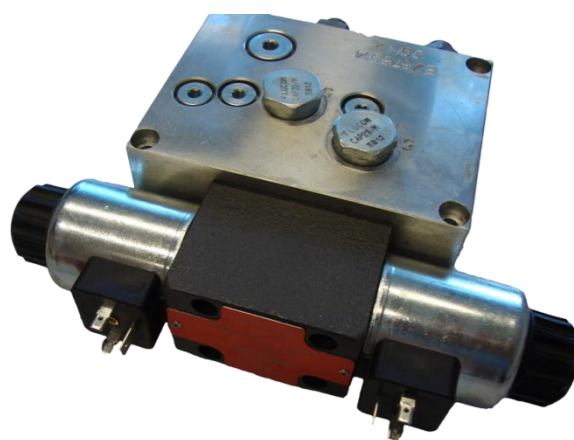

Figure 19 Implement manifold equipped with proportional valve

i Allow the oil from the tractor to warm up before starting the determination of the control rates.

i The steering can be checked by pressing one of the Test buttons on the tab page Steering and by observing whether any of the LED lights on the DIN connectors light up.

3.2.1. Proportional steering

1. In tab named "PID Steer" (Figure 18) select at "Controller Type": "Proportional"
2. Go to tab "Steering" (Figure 20). Check if steer left makes the cylinder steer left, if not mark the "L/R Inv" check box.
3. Use the "Test" button to the right of the control percentages to determine the maximum control speeds. Set up the max speeds for left and right in such a manner that the corresponding speed is between 0,8 – 1,0V/s. Make sure the actual speeds of left and right is more or less the same.

i Limit the max speeds between 0,8 – 1,0V/s

4. Use the "Test" buttons on the left of the control percentages to steer at the minimum control speed. Determine the left and right control speeds independently so that both minimum control speeds correspond to approximately 0.04 V/sec. The Side-Shift cylinder should respond immediately if the minimum values are set. Otherwise, increase the minimum control values.

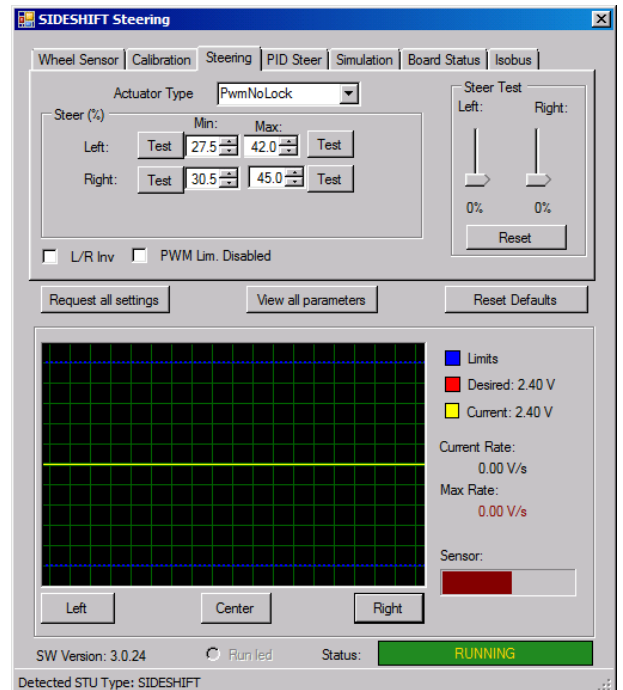

Figure 20 CANTool tab Steering

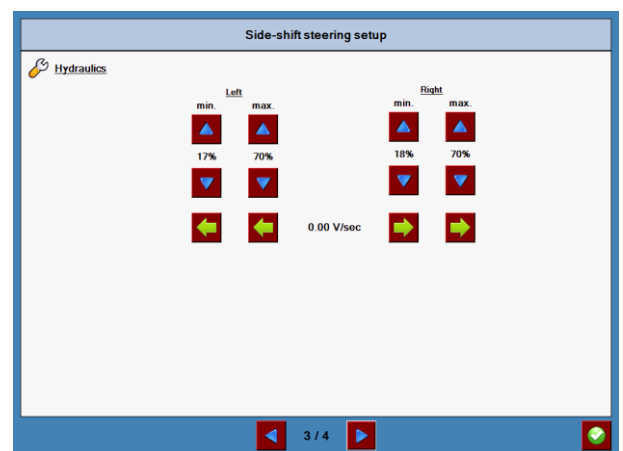





Figure 21 Calibration wizard SBGuidance; steering



-  *Determine the minimum control values in the central range (i.e. from the straight forward position).*

-  **Important:** *When minimum control values are applied, the control response to the left or to the right should be just as quick.*

-  **Important:** *The Side-Shift cylinder should respond immediately if the minimum values are set.*

-  *The minimum steering percentages can be fine-tuned in the SBGuidance user software too (Figure 21).*

3.2.2. Pulse steering

1. In tab named "PID Steer" (Figure 22) select at "Controller Type": "On/Off"
2. Go to tab "Steering" (Figure 23). Check if steer left makes the cylinder steer left, if not mark the "L/R Inv" check box.
3. Set the max. steering percentage to 100% when using an On/Off type hydraulic valve on the manifold. To do this select "PWM Lim. Disabled" and fill in 100% for both left and right. The steering speed needs to be adjusted using the mechanical choke valve present on the manifold.

If a proportional hydraulic valve is used the max steering percentages need to be set in such a manner that in case of a small steering input (pulse length of 300ms) the Side-Shift cylinder only moves about 1 cm. The max. steer percentages can also be determined when the SBGuidance software is active by setting the steering in "auto" mode and evaluating the movement of the cylinder. Adjust the max. steering percentages to adjust the movement of the cylinder. Make sure the actual speeds of left and right is more or less the same.

i Set max steering percentages to 100% for **On/Off hydraulic valves**.

i Limit the max steering percentages when using a **Proportional hydraulic valve!** In field operation the steering percentages can be altered in SBGuidance when fine-tuning is needed (Figure 21).

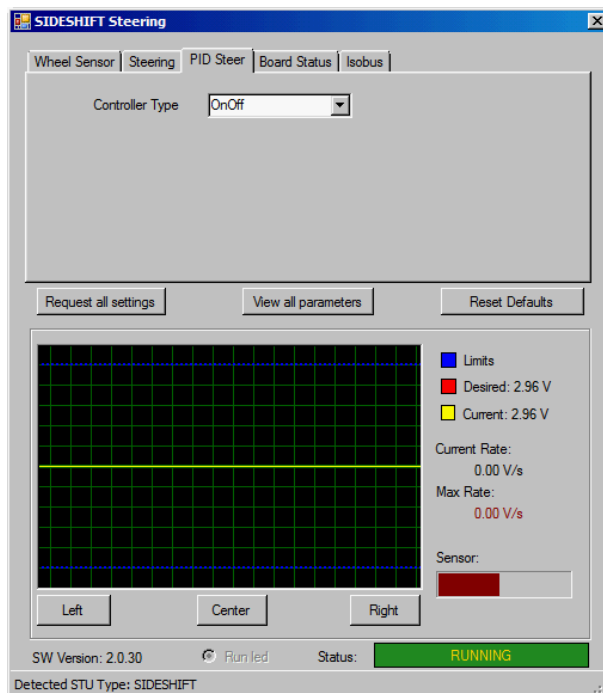

Figure 22 CANTool tab PID Steer On/Off

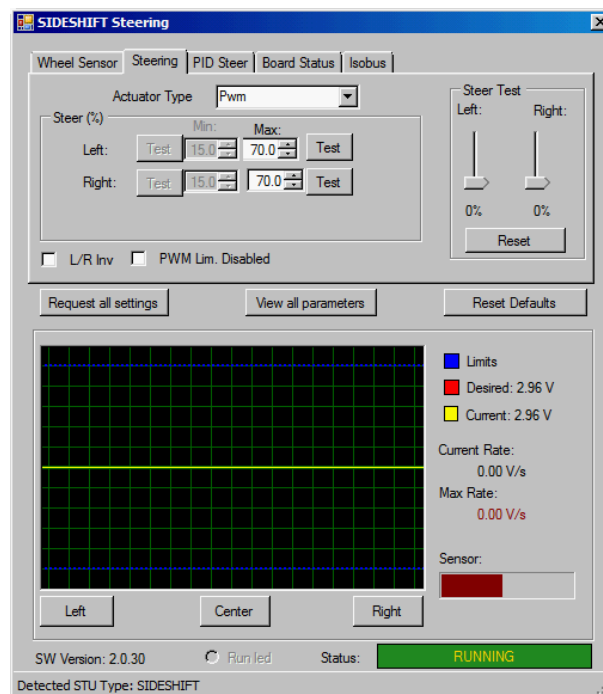

Figure 23 CANTool tablad Steering On/Off

3.3. Calibrating angle sensor

The angle sensor serves to provide feedback relating to the actual position of the Side-Shift cylinder or drawbar. Side-Shift steering uses the angle sensor for displaying the actual cylinder position in the software and making the “Auto-Centre” functionality useable. This is why calibrating the angle sensor is so important. Calibration can be performed from the tab Wheel Sensor (Figure 24), but also in SBGuidance (Figure 25).

1. Set both the left and right angle sensor limits by putting the cylinder/drawbar in its most outer position and save the corresponding voltages.
2. Determine the centre value of the angle sensor by cylinder/drawbar to the straight forward position and by pressing the Centre button.
3. Check the centre voltage when testing in the field. Read the centre voltage in the Calibration Wizard of SBGuidance (Figure 25) after driving for at least 50 metres in the automatic control mode. The centre voltage is used when Auto-Centre functionality is active.

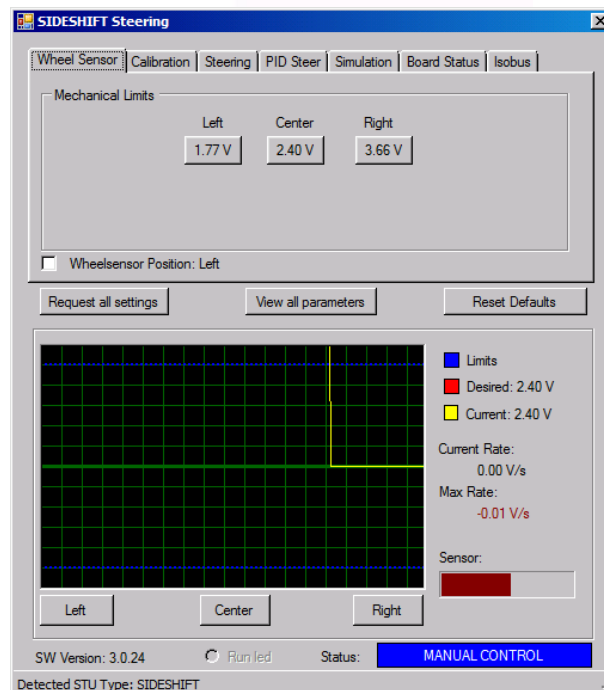

Figure 24 CAN-Tool tab Wheel Sensor

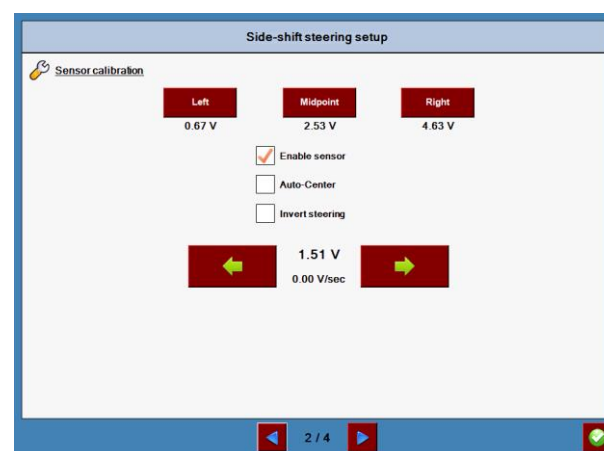

Figure 25 Calibrationwizard SBGuidance Angle Sensor

3.4. Configuration PID controllers

When using a proportional hydraulic valve the aggressiveness of the steering can be tuned in the ‘PID Steer’ tab. Use the default settings for the PID controllers as shown in Figure 26. The response of the controllers can be adjusted by changing the dealer gain percentages.

i Dealer gain PID Steer = hydraulic percentage

Increase the hydraulic percentage (PID Steer Dealer Gain) to obtain a more aggressive position control response.

The lower the max steering speed are set, the higher the hydraulic percentage can be.

Determine the gain in the field. Increase the hydraulic setting in SBGuidance if steering moves to slow to 0 cm deviation (Figure 27).

i The user can adjust the hydraulic setting in SBGuidance under Settings > Vehicle > Tuning > tab page Implement (Figure 27).

If adjusting the hydraulic value doesn’t have an immediate effect on getting the steering to work accurate, it may be necessary to change the min steering percentages. If the steering doesn’t react fast enough, increase both min steering percentages with 1%. If steering remains restless, try decreasing both min steering percentages with 1%.

i Pulse steering needs to be fine-tuned using the pulse-length and pulse-distance values (Settings > Vehicle > Tuning > tab page Implement).

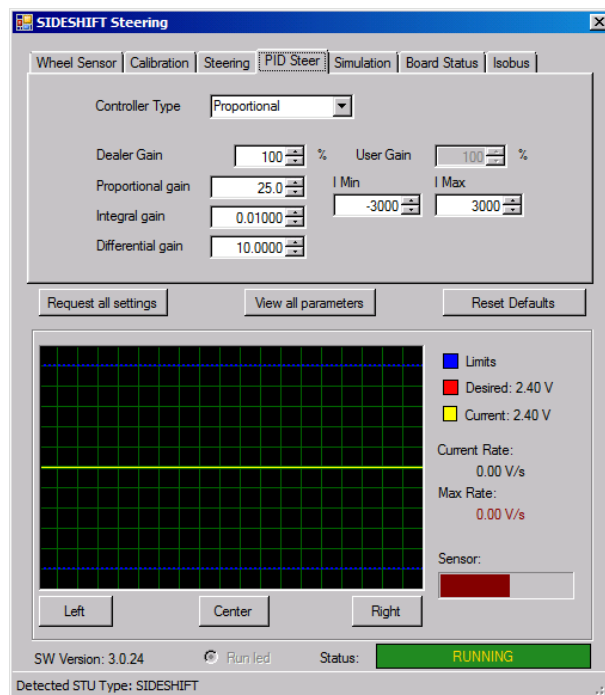

Figure 26 CAN-Tool tab PID Steer

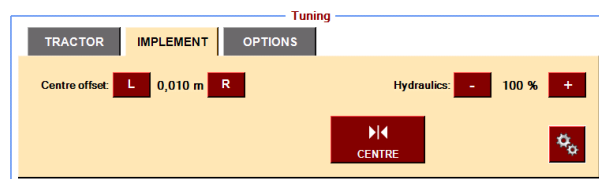

Figure 27 SBGuidance Side-Shift menu



3.5. Configurator set-up

Add an machine-profile to the loader screen and name it appropriately.

i Refer to the SBGuidance Auto CAN set-up and configuration manual for further information on how to install SBGuidance and make machine profiles.

Open SBGuidance Configurator for this machine-profile. Under Machine settings in the SBGuidance Configurator, set up and configure the system and guidance type. Select system type “**CAN**” and Guidance type “**SBGuidance Side-Shift**”. For the Orientation, select “**DynamiQ**”. If Side-Shift steering is used in a Twin-steering system, settings need to be set at **AUX**. If only Side-Shift steering is used settings need to be set at **Main**.

No parameters are required on the tab Side-Shift.

On the tab Machines, enter offset A (antenna height).

3.6. Calibrating DynamiQ

Calibrate the DynamiQ using the two-point calibration method. Calibration (Figure 28) can be performed in SBGuidance under INFO > GPS > Orientation > tab page Implement.

i Refer to the SBGuidance Auto CAN set-up and configuration manual for further information on how to install and calibrate the DynamiQ.

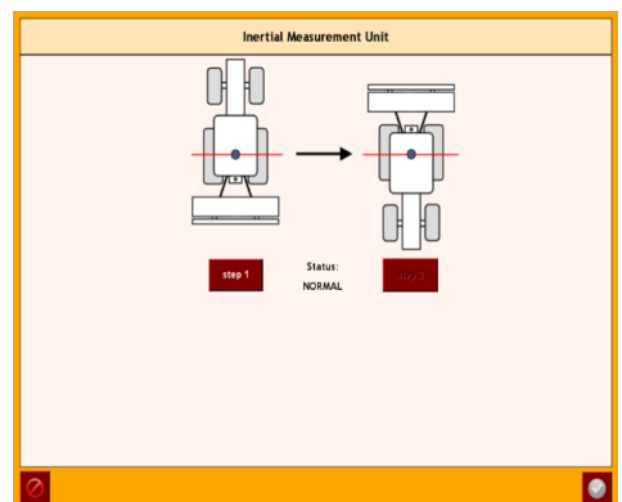

Figure 28 DynamiQ two-point calibration

3.7. Checking centre adjustments

The centre position of the Side-Shift system is important in order to ensure the correct successive follow-up of work operations. If the DynamiQ is calibrated and the GPS antenna is positioned physically in the centre of the implement, generally only a few cm need to be corrected.

Follow the steps described below:

1. First check the centre of the tractor.
Does the tractor drive back and forth in the same track?
2. The stabilization of the hitch must be locked.
3. Check that the correct working width has been entered.
4. Ensure that the Side-Shift system steers accurately with minimal or no deviations before the distance to the next furrow is measured.
5. Adjust the centre of the implement by half the measured error. The centre can be adjusted with the aid of the centre offset (Figure 29) in SBGuidance under Settings > Vehicle > Tuning > tab page Implement).

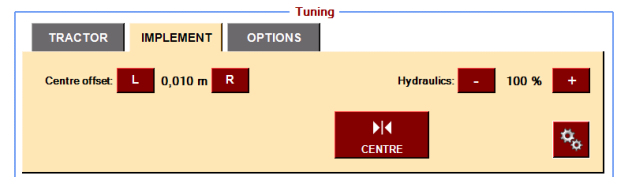

Figure 29 Centre offset Side-Shift Steering

4. Annex

4.1. Pin-out STU connectors

Table 2 STU B-connector (Black)

Pin	Description
1	VCC / PWM
2	ACT Ground
3	ACT Switched
4	ECU Power
5	Input 3 (no function)
6	5V sensor power (optional)
7	Angle sensor signal
8	Input 2 (no function)
9	ECU Power (12V sensor power)
10	ECU Ground (sensor ground)
11	ACT Ground
12	VCC / PWM

Table 3 STU A-connector (Gray)

Pin	Description
1	ACT Power
2	ACT Power
3	ECU Power
4	N.C.
5	N.C.
6	CAN High
7	CAN Low
8	N.C.
9	N.C.
10	ECU Ground
11	ACT Ground
12	ACT Ground



4.2. Pin-out Angle sensor

Table 4 Deutsch DTM06-4S angle sensor 12V

Pin	Description	Wire colour
1	5V sensor power	-
2	ECU ground	Blue
3	Sensor signal	Black
4	12V sensor power	Brown