



# INSTALLATION MANUAL

(English) (Translated version)

## SBGuidance Auto **SBG hydraulics (non steer-ready)**

016-8000-095EN Rev. A1





## Content

Content .....	3
Preface.....	5
Disclaimer.....	6
1. Instructions for installing the SBGuidance Auto on tractors .....	9
1.1 Overview of standard electronic components .....	10
1.2 Overview of standard mechanical components.....	11
1.3 Overview of make or type specific mechanical components .....	12
1.4 Make and type specific wheel angle sensor brackets.....	13
1.5 Overview of vehicle components .....	14
2. Tractor set assembly.....	15
3. Mounting the manifold and hydraulics .....	15
3.1 Hydraulic installation load sense .....	16
3.2 Connecting the shuttle valve.....	17
3.3 Hydraulic installation open center .....	18
3.4 Pressure relief valve .....	19
3.5 Hydraulic system on tractors with gear pump and load sense orbitrol connection .....	20
3.6 Mounting and connecting the steering controller .....	21
4. Mounting the wiring harness.....	23
4.1 CAN Basic Power harness.....	23
4.2 CAN Implement Ready (IR) Power harness.....	23
4.3 Installing the cable harnesses.....	24
4.4 Extra options in the wiring harness.....	26
4.4.1 TÜV options.....	26



4.4.2	ISOBUS RoadSwitch .....	28
4.4.3	Remote Go .....	28
5.	Mounting wheel angle sensor .....	29
5.1	Mounting spy-cable .....	29
5.2	Mounting the wheel angle sensor .....	30
5.2.1	Mounting of wheel angle sensor housing to standard front axle .....	30
5.2.2	Mounting the sensor disc .....	32
5.3	Heavy-duty Carraro front axle with independent suspension .....	36
6.	Mounting GPS and radio/gsm antenna .....	37
6.1	Mounting the standard GPS antenna bracket .....	38
6.2	Mounting of brand-dependent GPS antenna bracket .....	39
6.3	Mounting one's own design of GPS antenna bracket .....	39
6.4	Mounting Raven 600S antenna .....	40
6.5	Mounting the radio antenna .....	41
6.6	Mounting the GPRS/UMTS antenna .....	42
6.7	Mounting GPS Patch antenna .....	43
7.	Mounting DynamIQ ISO .....	45
8.	Installing the terminal .....	47
9.	Annexes .....	49
9.1	Pin-out Steering Controller .....	49
9.2	Schematic overview of system .....	50
9.3	Systematic overview Implement ready .....	51
9.4	Mounting 600S GPS-antenna .....	52

## Preface

This installation manual is intended for persons responsible for installing a SBGuidance Auto set with SBG hydraulics. The manual contains important instructions that should be complied with when commissioning, operating and servicing the SBGuidance system.

This manual has been compiled with the utmost care. SBG Precision Farming assumes no responsibility for any errors or omissions in this document.

Any comments or questions can be sent to [service-eu@ravenind.com](mailto:service-eu@ravenind.com).

**SBG Precision Farming or any of its suppliers will accept no liability for physical or material damage caused whilst using the SBGuidance system.**

The installed SBG system produces less than 70dB (A) noise.

This user guide uses a number of concepts for extra attention to a few things:



**Tip!:**

Provides recommendations on how certain activities can be performed much easier.



**Please note!:**

Indicates certain problems that the user should take note of.



**Caution!:**

Indicates that the machine can be damaged.



**Warning!:**

Indicates a risk of injury.

**SBG precision farming**

Hoornseweg 22

NL-1775 RB Middenmeer









E-Mail: [info@sbg.nl](mailto:info@sbg.nl)

Web: [www.sbg.nl](http://www.sbg.nl)

Phone: +31 (0)227 54 93 00



## Disclaimer

-  **Warning!**  
Always switch off the tractor before installing or repairing hydraulic and electrical components of the SBGuidance system.
-  **Warning!**  
The safety instructions contained in the manuals of the tractor or implements must be complied with at all times.
-  **Warning!**  
It is strictly prohibited to use the SBGuidance system on public roads.
-  **Warning!**  
It is strictly prohibited to leave a driving vehicle unattended when the SBGuidance system is switched on. The driver is always responsible for the direction and course of the vehicle.
-  **Warning!**  
To prevent injury or fire, replace defective fuses only with fuses of the same type and amperage.
-  **Warning!**  
The SBGuidance the operating system is not able to detect and avoid obstacles. If there is an obstacle in your path, you will always need to take action for it to be avoided.
-  **Warning!**  
Only allow authorized/qualified persons to operate the system. Authorized/qualified persons are defined as: persons who have read and understood the manual, have been given instructions by a product specialist, and who are both physically and mentally fit and able to operate the system.
-  **Warning!**  
In case of system failure or breakdown switch of the tractor and disconnect the electrical power source to avoid further damage. Contact your dealer for further instructions on how to repair your system.
-  **Warning!**  
The system contains moving parts! Make sure the immediate environment is clear of people before operating the system.



**Warning!**

Always wear personal protective equipment when operating/adjusting/repairing the system outside of the tractor cab.



**Caution!**

In order to prevent power surges from occurring, always start the machine first, before initiating the SBGuidance control system.



**Caution!**

Only touch the touch-screen with your finger or by using a special touch-screen stylus/pen. Operating the touch-screen with sharp objects may cause permanent damage to the screen.



**Caution!**

Always consult your supplier as to which products are best suited first before cleaning the touch-screen with chemicals or alcohol.



**Please note!**

If the terminal is not used for a long period, better remove the terminal from the tractor and store in a heated environment. This will extend the life span of the electronic components.



**Please note!**

To prevent theft, it is better to not let the terminal and GPS-antenna unattended in the tractor on the field.



Intentionally left blank



## 1. Instructions for installing the SBGuidance Auto on tractors

This manual is a general guide and is not intended for any specific make or type. This chapter provides overviews of the standard components that can be supplied with the tractor sets. The number of parts in the delivery will depend on the make and type of tractor for which the set is intended.

All necessary parts are supplied, including this manual. Verify that all items listed on the packing list are actually present.



### 1.1 Overview of standard electronic components

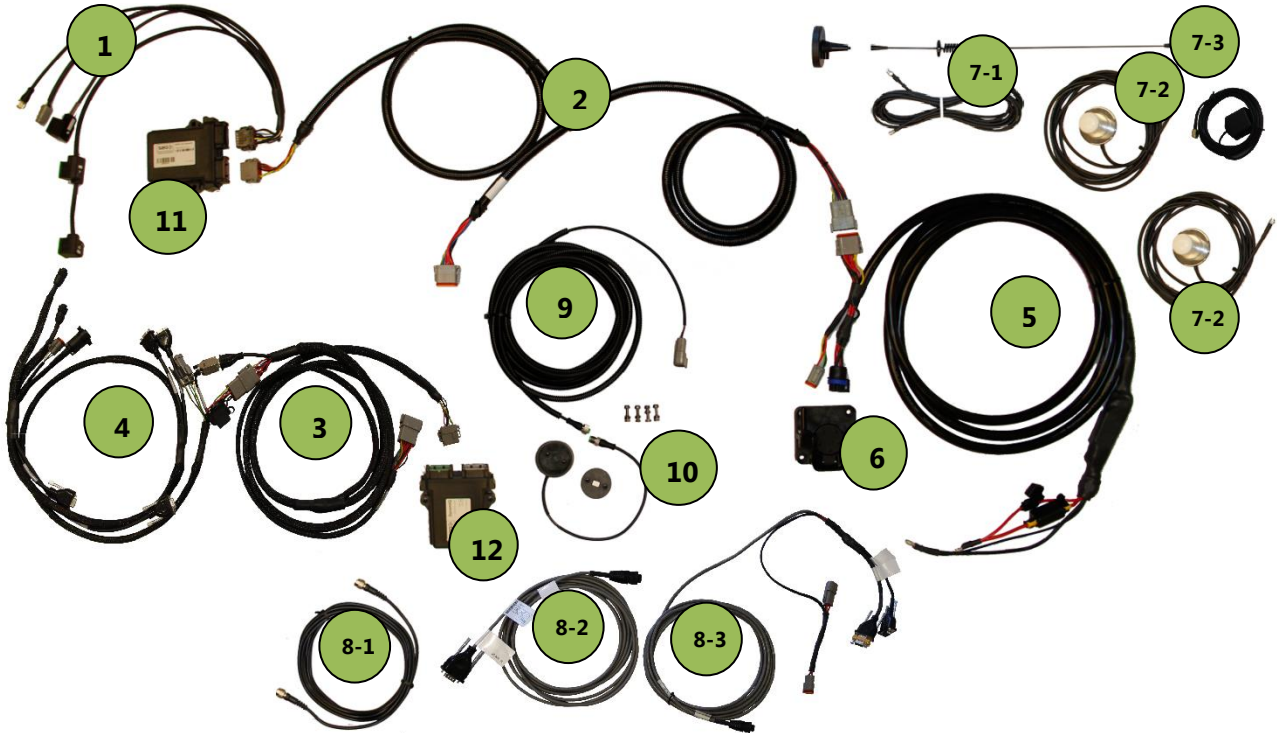

Symbol	Order no.	Description
1	SBG13710-06	Harness STU - Manifold V3
2	SBG13711	Harness chassis (hydraulics)
3	11158000063	Harness in-cab (DynamIQ ISO)
4	11158000064	Harness in-cab VPR4 ISO
5	SBG13712	Power harness - Basic
5	SBG13712-01	Power harness - Implement Ready (IR)
6	SBG13581-01	Implement socket (IBBC)
7-1	SBG10100-02	Radio antenna with magnetic base
7-2	SBG10385	GSM antenna LAIRD - 3,5M
7-3	10638000015	Field hub GPS patch antenna 4,5m
8-1	SBG10043-01	GPS antenna cable TNC-TNC 4,5m
8-2	11150171890	Cable 12' modem to receiver
8-3	11158000011	Cable, 600S to Viper 4
9	SBG11901-01	Wheel angle sensor 12V 90° 35CM
10	SBG11901-08	Harness wheel angle sensor 5m
11	SBG10919-02	Tractor Steering Controller
12	10630173862	DynamIQ ISO - Tractor



**Tip!:**

To mark the cables at the terminal side, a set of labels is provided with the antenna cables,. A set of SMA-grips is provided to moderate the connection of the GSM and GPS Patch antennas to the Slingshot.

### 1.2 Overview of standard mechanical components

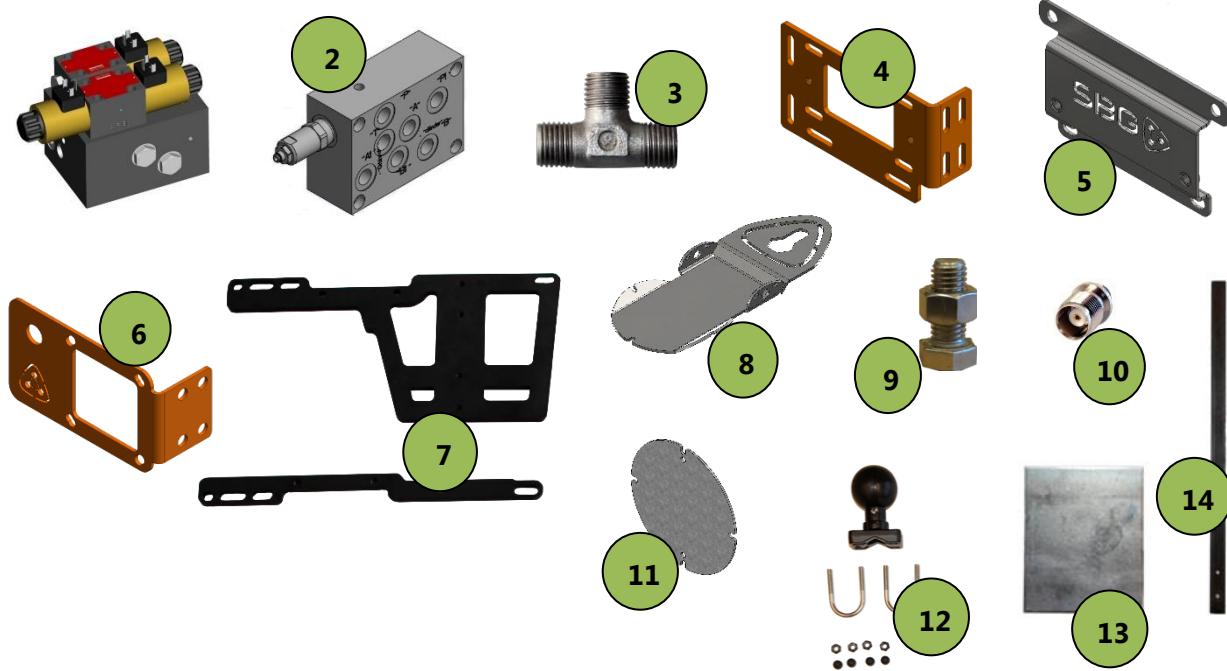

Symbol	Order no.	Description
1	SBG10660-02	Manifold V3.1 (load sense)
2	SBG10661-02	Manifold add-on O.C. V2
3	SBG10710	Shuttle valve 8L (load sense)
4	SBG11823-01	Manifold V3 bracket universal
5	SBG12705-05	Steering Controller bracket
6	SBG12705	IBBC bracket (only with CAN IR harness)
7	SBG12700-01	DynamIQ ISO mounting bracket V4
8	SBG12198	GPS/Radio bracket universal
9	SBG10002	UNC bolt en nut
10	SBG10010	TNC dummy
11	SBG12244	Radio/GSM roof mounting plate
12	SBG11043	RAM U-Bolt Base
13	SBG12120	Wheel angle sensor mounting plate universal 90x110
14	SBG12000	Wheel angle sensor mounting strip
	SBG10021-02	Mounting kit

**i Tip!:** Shuttle valves in sizes 10L, 12L and a CNH shuttle valve (ORFS) are available on request.

**i Tip!:** The provided mounting kit SBG10021-02 contains all fasteners for the components.



### 1.3 Overview of make or type specific mechanical components

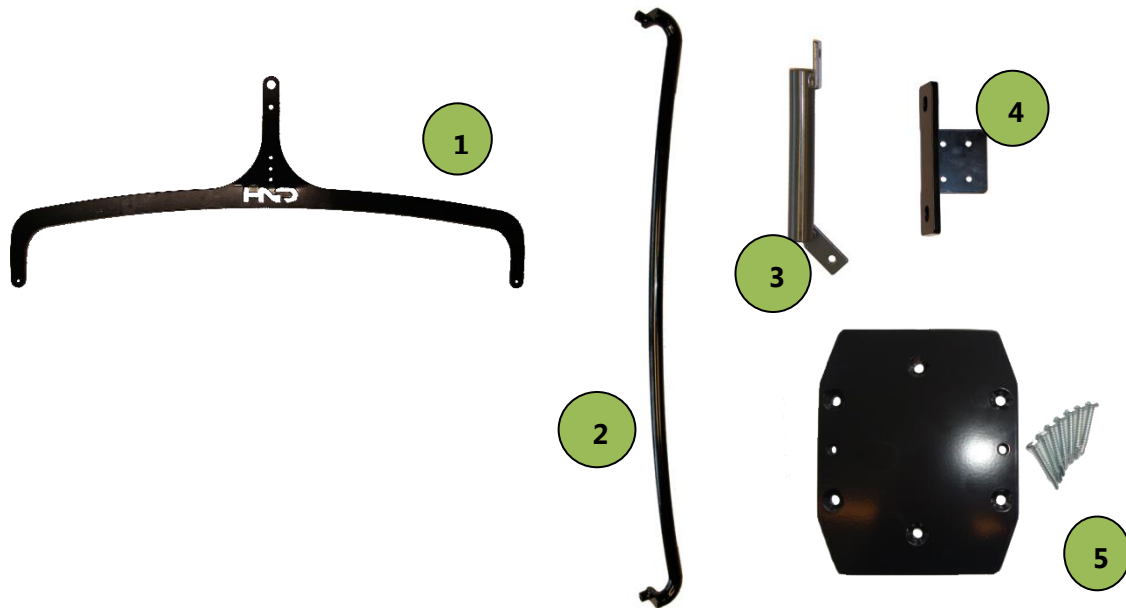

Symbol	Order no.	Description
1	SBG12194	CNH – GPS-antenna bracket (T6000, T7000, T6, T7 en Case Maxxum/Puma)
2	SBG11850-01	Fendt SCR RAM bracket (Visio plus cab, 500 en 700-SCR series)
3	SBG11850	Fendt RAM bracket (Fendt Vario 400, 700, 800 en 900-series met com3-cab)
4	SBG11154	RAM mounting bracket cab e.g. for JD/CNH (for tractors with universal (120mm) mounting points)
5	SBG12700	DynamIQ ISO mounting bracket v1 (universal)

1.4 Make and type specific wheel angle sensor brackets

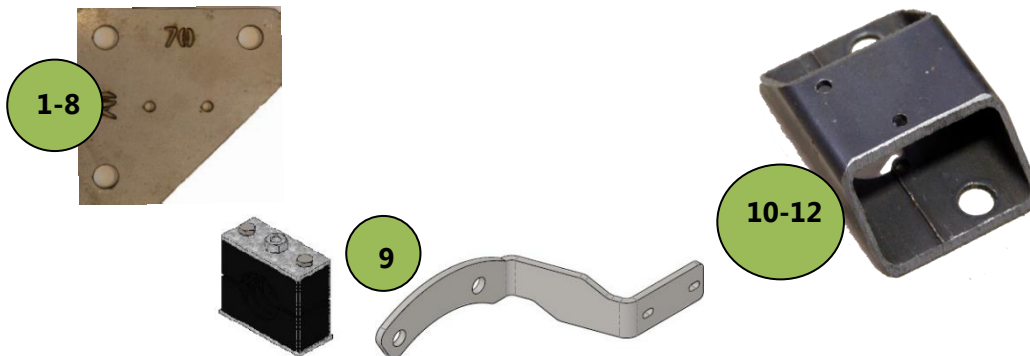

Symbol	Order no.	Description
1	SBG12120-01	Wheel angle sensor bracket 60x70 (John Deere 6x30 4-cylinder)
2	SBG12120-02	Wheel angle sensor bracket 60x80 (Fendt 7xx-8xx)
3	SBG12120-03	Wheel angle sensor bracket 60x90
4	SBG12120-04	Wheel angle sensor bracket 50x60
5	SBG12120-05	Wheel angle sensor bracket 66x66 (John Deere 6xxx 4-cylinder)
6	SBG12120-10	Wheel angle sensor bracket 76x76 (John Deere 6x20/6x30 6-cylinder)
7	SBG12120-11	Wheel angle sensor bracket 70x70 ( Fendt 4xx, Valtra 6x50, Valtra N-series & T-series)
8	SBG12120-12	Wheel angle sensor bracket 112x92
9	SBG12120-22	Wheel angle sensor brackets Carraro front axle V2
10	SBG12123	Wheel angle sensor bracket pipe 65.3 mm
11	SBG12123-01	Wheel angle sensor bracket pipe 88 mm
12	SBG12123-03	Wheel angle sensor bracket pipe 73.5 mm



**Tip!:**

The indicated measurements of the wheel angle sensor brackets are center bolt hole to center bolt hole.



### 1.5 Overview of vehicle components

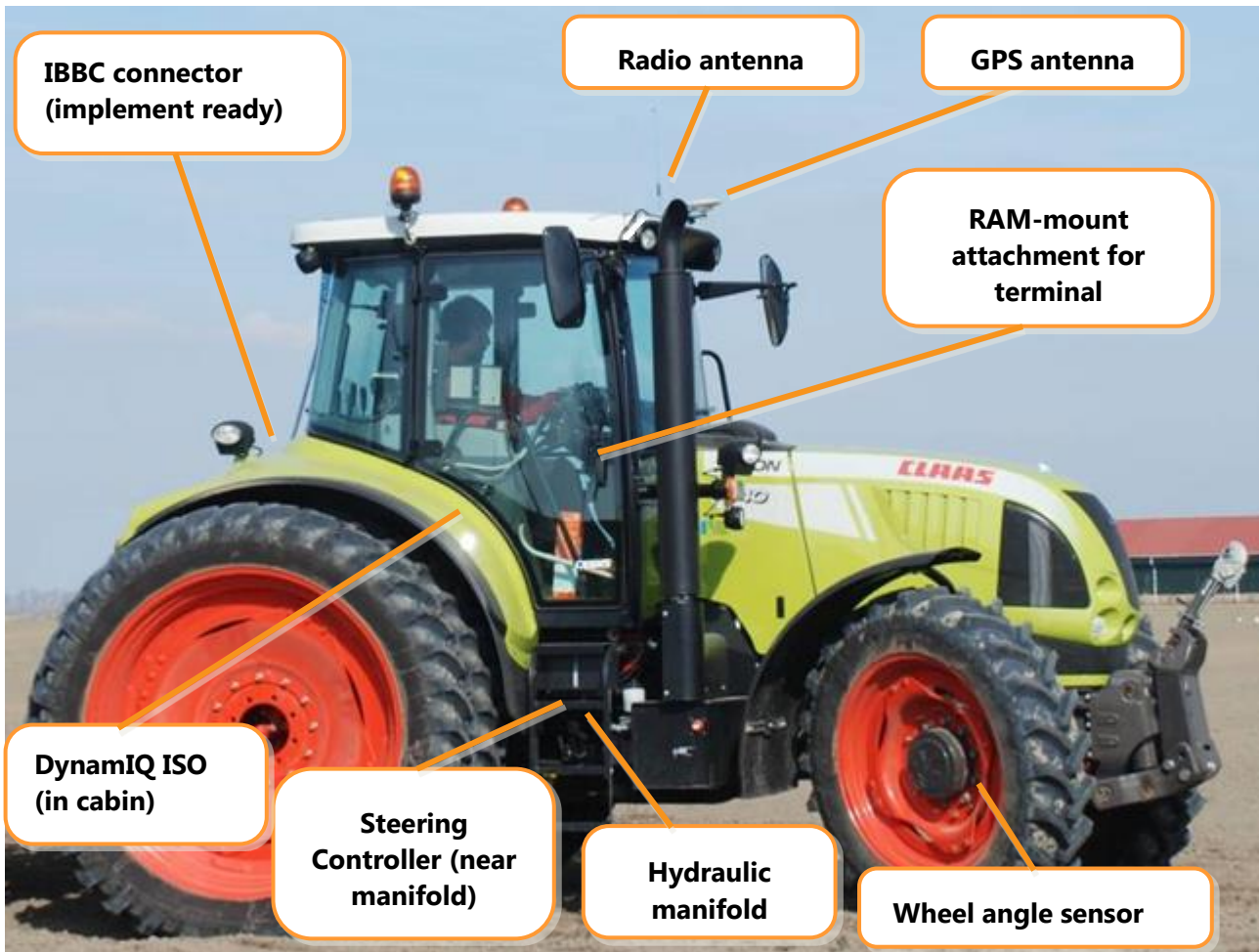

## 2. Tractor set assembly

It is recommended to assemble the tractor set in the following order:

1. Mount the hydraulic manifold and all hydraulic hoses.
2. Mount the steering controller to the hydraulic manifold.
3. Mount the entire wiring harness from the battery.
4. Mount the wheel angle sensor and cable.
5. Mount the GPS antenna and radio/GSM antennas and all antenna cables.
6. Mount the DynamIQ ISO.
7. Mount the terminal.

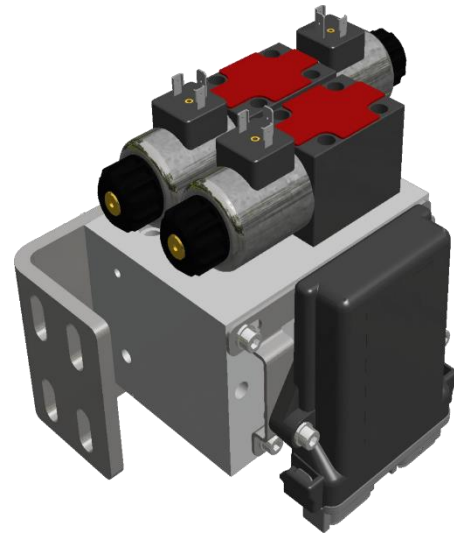

Figure 1 Manifold bracket with a manifold and steering controller mounted.

## 3. Mounting the manifold and hydraulics

Figure 1 shows a manifold mounted onto a manifold bracket with four M8 bolts. The manifold bracket is preferably mounted at the right hand side of the tractor (Figure 2). This is usually the side of the tractor with the most space.



**Pay attention!:**

*Make sure the connectors of the valves and the pressure sensor can still be connected after mounting the manifold.*



Figure 2 Mounted manifold and steering controller.



### 3.1 Hydraulic installation load sense

The manifold should be connected between the hoses leading from the steering orbitrol to the steering cylinder(s). To do so, the hoses must be disconnected, preferably on an existing connection between a pipe line and a hose.

Connect the hoses from the steering orbitrol to **A1** and **B1** on the manifold. Connect the hoses to the steering cylinders to **A** and **B** on the manifold (Figure 3 and Figure 4).

Connect the pressure line, return line and the LS line of the hydraulic pump to the **P**, **T** and **LS** of the manifold. When needed refer to the hydraulic drawing of the tractor to find the correct connections on the tractor.

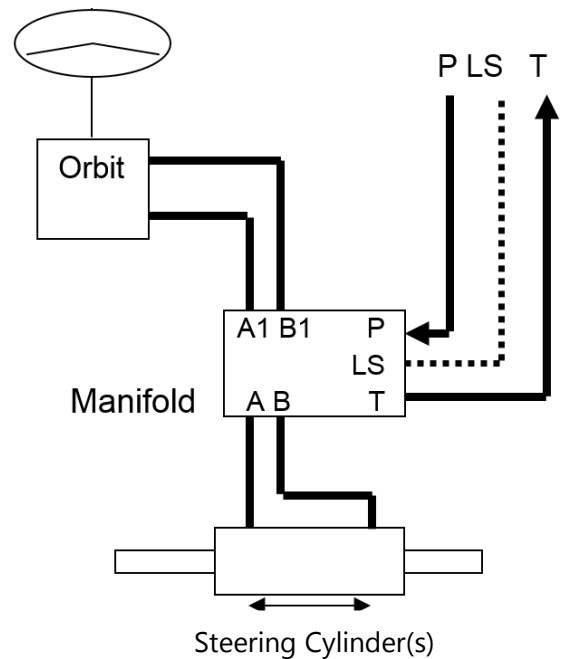

Figure 3 Load sense connecting circuit.



**Caution!**

*If there are separate hydraulic systems with separate oil tanks on the tractor, the manifold must be connected to the system in which the steering orbitrol and steering cylinder are included in.*



**Tip!**

*Mark the lines twice with 'A' and 'B', before disconnecting them.*



**Tip!**

*SBG Precision Farming can supplies hose kits for different types of tractors. Please inquire about the possibilities.*

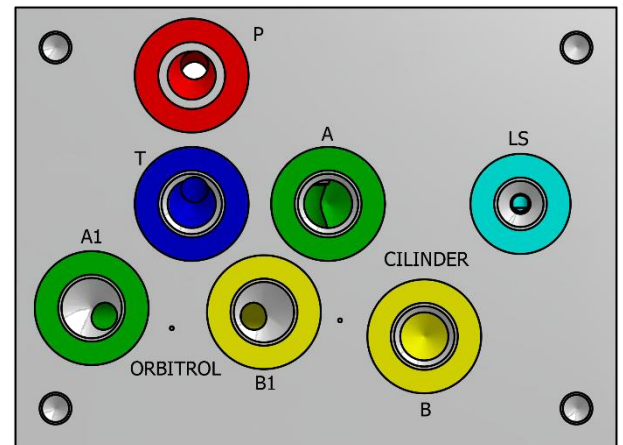

Figure 4 Connections for the hydraulic load sense manifold.



### 3.2 Connecting the shuttle valve

A shuttle valve should be installed in the load sense line. See Figure 5 for proper mounting and orientation of the shuttle valve. This way, when in rest, the ball inside the shuttle valve floats inside the valve, which will benefit the response for the load sense signal. In addition, it is important that the shuttle valve is installed as close to the pump as possible.



Figure 5 Top view of shuttle valve for mounting in the load sense line.



**Tip!:**

*In case the wheels of the tractor steering, as soon as the hydraulics of the tractor are operated; a non-return valve should be mounted in the load sense line from the manifold. The non-return valve should let oil pass from the manifold to the check valve/pump and should block in opposite direction.*



**Tip!:**

*A shuttle valve for CNH tractors can be provided by SBG (order no. SBG10713) or the local CNH dealer (order no. 82018814).*



### 3.3 Hydraulic installation open center

The manifold v3 open center consists of the standard load sense manifold v3 with an add-on open center part (Figure 6).

The pressure line that normally runs from the hydraulic pump to the steering orbitrol, should be connected to the **P** of the add-on open center part. Then connect a line between **P1** of the manifold and the pressure line of the orbitrol. Connect the **T** of the manifold to a tank inlet (Figure 7 and Figure 8).

Connect the hoses leading from the orbitrol to **A1** and **B1** on the manifold. Connect the hoses to the steering cylinders to **A** and **B** of the manifold (Figure 7 and Figure 8).

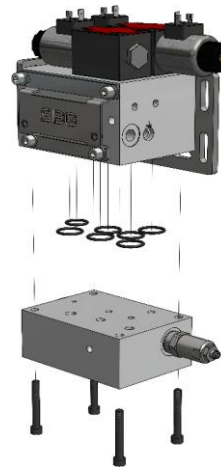

**Figure 6 Add-on part of the open center manifold.**

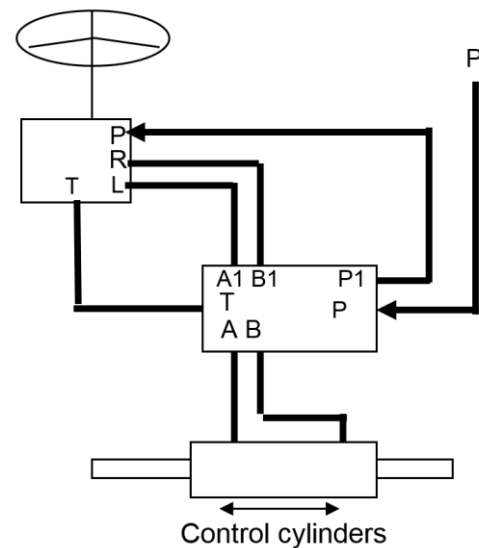

**Figure 7 Open center connection circuit.**

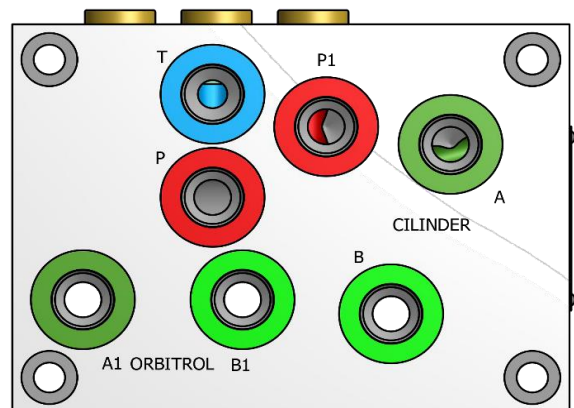

**Figure 8 Connections of the hydraulic open center manifold.**

### 3.4 Pressure relief valve

A pressure relief valve is mounted to the add-on part of the open center manifold (Figure 9). This pressure relief valve must be set to the maximum allowable control pressure of the steering system. The default setting of the pressure relief valve is about 180 bar. Determine the maximum pressure of the steering system before mounting the manifold. Follow the next steps:

- Mount a pressure gauge in the pressure line between the hydraulic pump and the steering orbitrol.
- Steer the front wheels to one side and keep steering until the maximum pressure is reached.
- Read out the value on the pressure gauge.

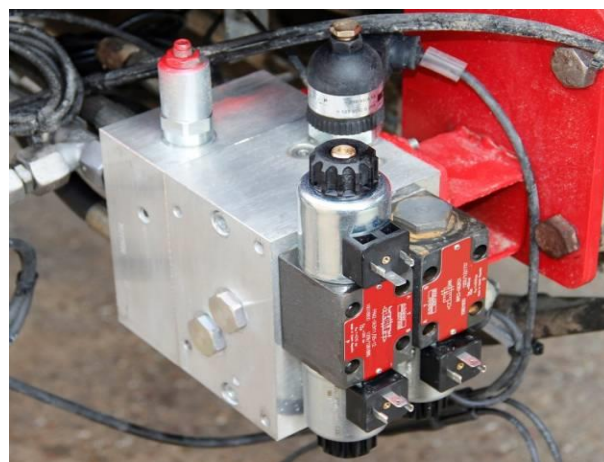

Figure 9 Open center manifold.

After mounting the manifold. Set the maximum pressure of the pressure relief valve, equal to the maximum pressure of the steering system. Follow the next steps:

- Mount a pressure gauge in the pressure line between the hydraulic pump and the manifold.
- Loosen the locking nut of the pressure relief valve.
- Loosen the pressure relief valve two turns counter clockwise.
- Steer the front wheels to one side, using the CANtool. And keep steering until the maximum pressure is reached.
- Read out the value on the pressure gauge.
- Adjust the pressure relief valve until the pressure is equal to the pressure it was before mounting the manifold.
- Secure the pressure relief valve with the locking nut.

For steering the wheels with the CANtool, see: '016-8000-100EN-A Configuration manual - SBGuidance Auto – CAN - 4.x'.



### 3.5 Hydraulic system on tractors with gear pump and load sense orbitrol connection

Tractors with a gear-type pump and equipped with an orbitrol with load sense connection fitted with a load sense priority valve. This concerns most Valtra models (Advanced, Versu and Direct) and for some Deutz-Fahr models.

This enables the use of a standard load sense manifold with a shuttle valve. Because the maximum pressure is normally limited by the steering orbitrol, an additional pressure relief valve needs to be installed in the pressure line to the manifold.

The load sense signal should be connected to the existing load sense line from the steering orbitrol by using the shuttle valve supplied. Preferably mount the shuttle valve horizontally. Connect the hydraulics hoses as indicated in Figure 10.

Determine the maximum pressure of the steering system before mounting the manifold. The maximum pressure of the additional pressure relief valve should be set equal to the maximum pressure of the steering system, before mounting the manifold.

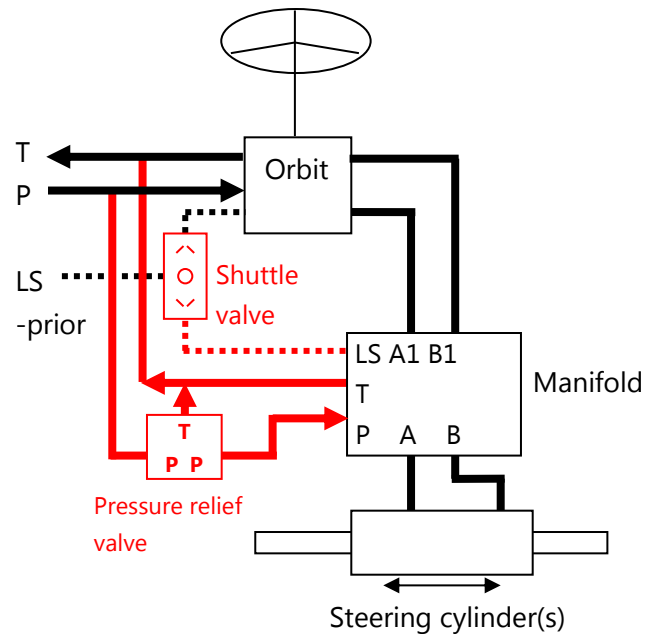

**Figure 10** Connecting circuit for LS priority valve.

### 3.6 Mounting and connecting the steering controller

The steering controller bracket can be mounted to the manifold. The steering controller can then be fitted to the manifold bracket (Figure 11).

Important notes when mounting the controller:

- Mount the steering controller with connectors directed downwards to prevent the ingress of water.
- Do not mount the steering controller too close to parts which have a high temperature (for example, the exhaust system of the tractor).

Connect the DIN connectors marked "Left" and "Right" to the proportional valve. Connect the DIN connector marked "Lock" to the shut-off valve. Connect the 4-pin Phoenix M12 connector to the pressure sensor of the manifold.

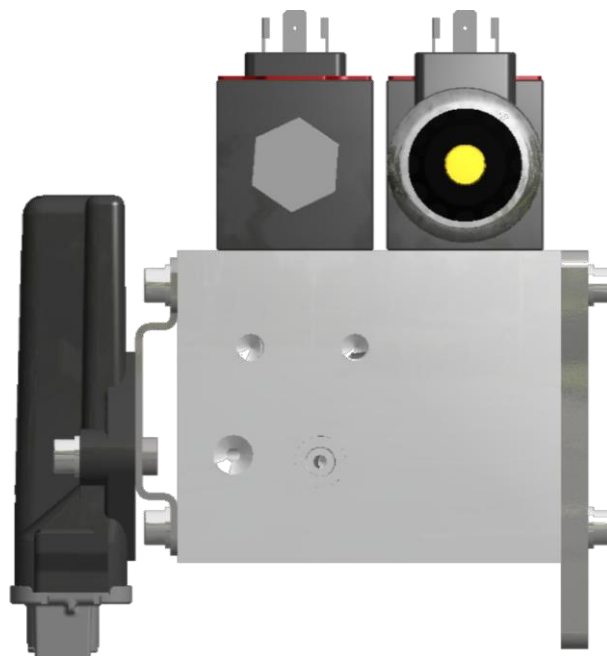

Figure 11 Side view of the steering controller fitted to the manifold.



#### Pay attention!:

The torque of the pressure sensor in the manifold V3 is 50 Nm. It is not necessary to check this at delivery of a completely assembled manifold. However, make sure, when replacing the pressure sensor, that it is tightened with the correct torque.



Intentionally left blank

## 4. Mounting the wiring harness

The total SBG cable harness exist of several cables, from the battery to the terminal (see Figure 53 and Figure 54). SBG offers two power harness options; the CAN Basic harness or the Implement Ready (IR) harness. As an in-cab terminal harness SBG offers a harness to connect the Viper 4(+) or the older GeoStar terminal. With an adapter harness it is also possible to connect a Viper 4(+) to the GeoStar terminal harness.

### 4.1 CAN Basic Power harness

The basic harness can only be used for tractor steering. If the tractor is fitted with this harness, it is not possible to use the tractor for implement steering (TWIN, plough).

### 4.2 CAN Implement Ready (IR) Power harness

With an Implement Ready harness the tractor can be used both for tractor and implement steering. The IBBC connector can be used to connect an implement (Figure 12). The Implement Ready power harness runs from the battery to the IBBC connector at the rear of the tractor. It branches off to connect the STU chassis harness and contains fuses near the split.



Figure 12 IBBC bracket with connector.



### 4.3 Installing the cable harnesses

Both the CAN basic harness and the CAN implement ready harness are divided into the following harnesses (in order from the battery):

1. Power harness: an Implement Ready power harness is mounted from the battery to the rear of the tractor. A Basic power harness is mounted from the battery to the chassis harness. Make sure that the relays and fuses are mounted in a dry, clean and accessible spot (Figure 13).
2. Chassis harness: runs along the chassis of the tractor and is wrapped in a hard casing. The harness branches off to the steering controller.
3. In-cab harness (DynamIQ ISO): runs from the chassis harness into the cab and is wrapped in a braided sleeve casing. It branches off to the DynamIQ ISO.
4. Terminal harness: runs from the the In-Cab harness (DynamIQ ISO) to the terminal. The terminal harness is connected with two connectors to the in-cab harness (DynamIQ ISO). When using a Raven 600S GPS receiver, the 600S harness is connected to the terminal harness too (see Figure 55).

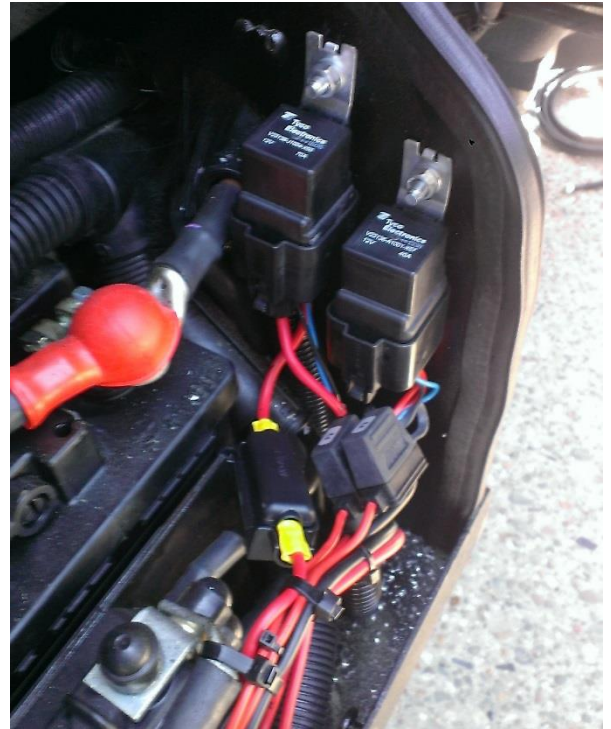

**Figure 13 Relays and fuses of the power harness.**

Figure 53 and Figure 54 of the annexes show the schematic drawings of both the CAN basic harness and the CAN Implement harness.

In addition, a number of guidelines have been established for the assembly of both types of cable harnesses:

- Mount the relays fixed and in a dry, clean and accessible spot (Figure 13).
- The red wire is + (12V). The black wire is (ground). Make sure that the first part of the red wire (part in between battery and fuses) cannot damage during operation.



- If necessary the positive and negative wires, in between the battery and the fuses, can be shortened. Be sure to use cable sockets with the correct size for proper connection.
- If a ground switch is used, connect the wiring harness behind the ground switch (not at the battery side of the ground switch!).
- If a main (12V) switch is used in the red wire, connect the wiring harness behind the main switch (not at the battery side of the main switch!).
- If no main switch is used, always connect the wiring harness directly to the battery.
- If the system is connected to a 24 Volt machine, always use a 24V to 12V converter. Never connect between the two batteries of a 24V machine!
- Lead the terminal harness along with the GPS and radio/GSM antenna cables through one pillar of the cab.
- Tie-wrap the wires so they are attached free from vibration and friction.

**Caution!**

*It is Important to ensure that the wiring harness is always connected to the battery AFTER installing all wires and controllers!*

**Tip!**

*The pinning of the connectors in the wiring harness is described in section 9.1.*



## 4.4 Extra options in the wiring harness

### 4.4.1 TÜV options

A 'master switch' and an 'operator presence cable' should be mounted to meet the standards of the German TÜV approval (Figure 14).

The 'master switch' can be used to switch ACT-power and ECU-power off during road transport of the vehicle. The switch must be mounted within view and reach of the driver. The switch is available in two sizes, 44x22mm and 36x21mm.

The switch can be connected to the terminal harness by using the supplied short connection cable (Figure 15).

Take the following steps to connect the switch:

- Remove the wedge from the 12 pin DT connector of the terminal harness.
- Remove the wedge from the 4 pin DT connector of the short connection cable.
- Remove the blue wire, pin 8 from the 12 pin DT connector.
- Insert the blue wire of the short connection cable as pin 8 from the 12 pin DT connector (Figure 16).
- Insert the blue wire of the terminal harness as pin 3 from the 4 pin DT connector.
- Remove the seals from the cavities of pin 1 and pin 12 of the 12 pin DT connector.
- Insert the red wire of the short connection cable as pin 1 of the 12 pin DT connector.
- Insert the black wire of the short connection cable as pin 12 of the 12 pin DT connector (Figure 17).
- Re-insert the wedges in both DT connectors.
- Connect the harness with the master switch to the 4 pin DT connector (Figure 18).



**Figure 14 Master switch.**

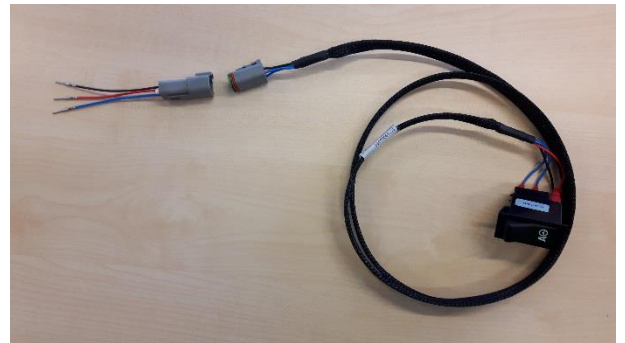

**Figure 15 Cable master switch.**

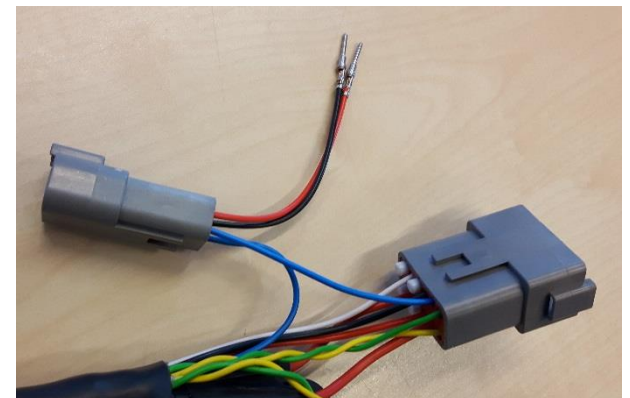

**Figure 16 The short cable on the terminal harness.**

An 'operator presence cable' connects the seat switch of the tractor to the DynamIQ ISO. A few seconds after the driver has left the seat, the automatic steering will be deactivated.

To connect the seat switch to the DynamIQ ISO, disconnect the current connectors of the seat switch of the tractor and mount the SBG seat switch cable in between these connectors. Cables for various types of tractors are available on request.

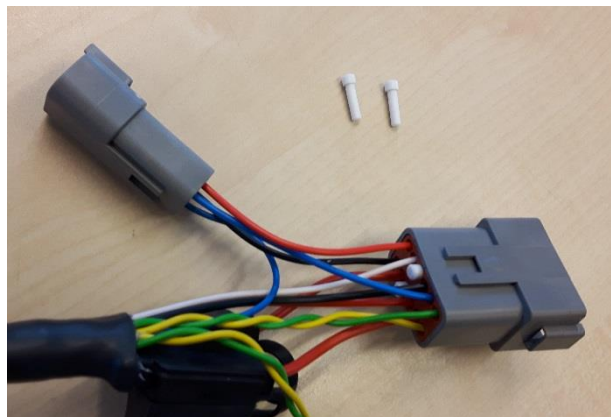

**Figure 17** The short connection cable on the terminal harness.



**Figure 18** Master switch connected to the terminal harness.



#### 4.4.2 ISOBUS RoadSwitch

The ISOBUS RoadSwitch (Figure 19) can be used as a master switch, which switches ACT-power and ECU-power off during road transport.

The ISOBUS RoadSwitch can also be used to connect an ISOBUS Virtual Terminal. With this module the tractor is actually ISOBUS Ready. The ISOBUS implement can be connected directly to the SBG IBBC connector on the back of the tractor.

The RoadSwitch has a T-cable which should be mounted in between the harness in-cab VPR4 ISO (11158000064) and the harness in-cab DynamIQ ISO (11158000063). The RoadSwitch should be installed on a clearly visible and easily accessible position (Figure 19).



**Figure 19 Raven Roadswitch.**

#### 4.4.3 Remote Go

To activate the steering system it is possible to mount an external button (SBG13710-20; Figure 20). This button can be installed in the armrest or console of the machine and should be connected to the DynamIQ ISO. For this option a SmartRemote license is necessary.

For more information about the installation and configuration in the software, see the: '016-8000-037NL-A Configuration manual – IO Controller DynamIQ'.



**Figure 20 Remote GO.**

## 5. Mounting wheel angle sensor

For a correct operation of the SBG system a wheel angle sensor is necessary. In various types of tractors a factory fitted wheel angle sensor is already mounted in the front axle. For different tractor types a 'spy cable' is available at SBG to use the factory fitted wheel angle sensor for the SBG system. When a spy cable is used it is not necessary to install a SBG wheel angle sensor. Ask SBG for more information about the availability for a specific tractor brand or type.

### 5.1 Mounting spy-cable

Take the following steps to mount a wheel angle sensor spy-cable:

1. Follow the cable from the wheel angle sensor on the front axle of the tractor to the first connection in this cable.
2. Disconnect the connectors.
3. Connect the spy-cable in between the connectors.
4. Connect the wheel angle sensor 5M cable to the M12 connector of the spy-cable.
5. Mount the spy-cable in a clean and dry position (Figure 21).



Figure 21 Spy cable mounted on a CNH tractor.



## 5.2 Mounting the wheel angle sensor

Figure 22 and Figure 23 show a detailed view of the structure of a wheel angle sensor assembly. Table 1 also lists the components shown in Figure 22.

**Table 1 Wheel angle sensor components.**

Symbol	Description
1	Sensor housing
2	Sensor disc
3	Mounting bracket 3mm
4	Mounting strip 20x 3mm
5	2 x M5 x 16mm (countersunk head)
6	2 x M5 x 30mm

### 5.2.1 Mounting of wheel angle sensor housing to standard front axle

1. If the front wheels are straight, the screws of the sensor housing and sensor disc should be aligned with the front axle. In case of a 12V wheel angle sensor, it is also important that the sensor disc is rotated in such a way that the triangles in the disc and the sensor housing (Figure 24) are properly aligned. Only then will the wheel angle sensor produce a voltage reading.
2. The sensor housing and sensor disc must be aligned EXACTLY on the pivot point of the stub axle. The centre-to-centre distance of the mounting holes is 28 mm.



**Please note!:**

*With a 12V wheel angle sensor, the triangles on the sensor housing and sensor disc must be pointing in the same direction!*

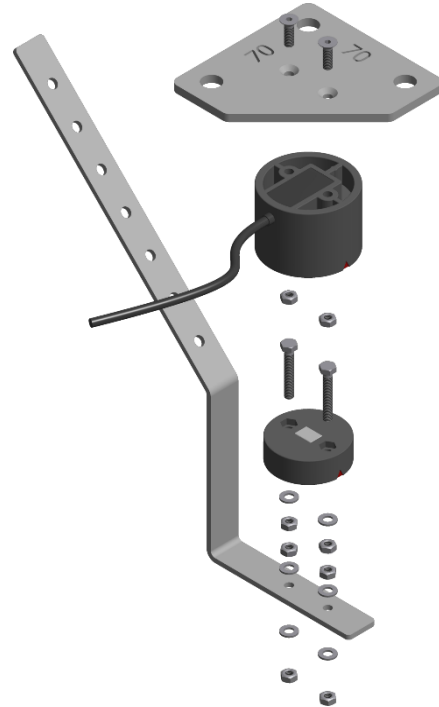

**Figure 22 Schematic overview of wheel angle sensor with mounting bracket and strip.**

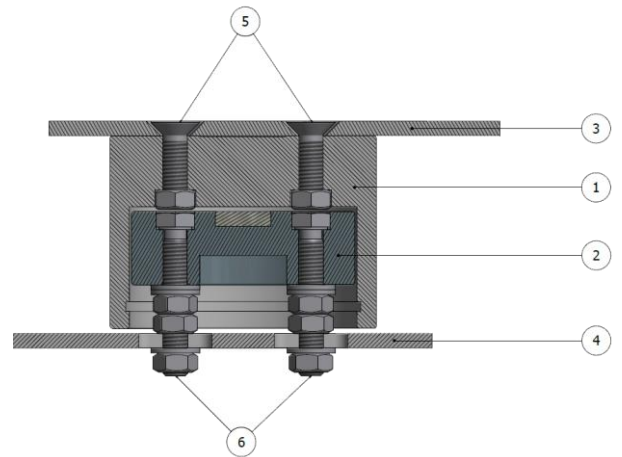

**Figure 23 Schematic drawing of wheel angle sensor when mounted.**

3. If there is a grease nipple at the bottom of the stub axle (stub axle with triangle), then a special U-shaped bracket is to be used for the wheel angle sensor housing (Figure 25 and Figure 26). See section 1.4 for the available wheel angle sensor mounting brackets.
4. It is recommended to assemble the sensor housing on the bottom side of the axle stub. Install the sensor housing with the wire pointing backwards.

**! Caution!**

*Sensor housing should always be mounted upright to prevent the accumulation of dirt.*

5. Mount the sensor housing with the M5X16 bolts (allen bolt, countersunk head). Countersink the drill holes in the wheel angle sensor mounting bracket beforehand, so the heads of the M5 bolts are fully countersunk in the mounting bracket when tightened (Figure 23). To prevent damage to the inside of the the sensor housing, make sure the M5 bolts are not too long.
6. The connecting cable can be provided with a protective sleeve for longer life. Feed the cable via the stub axle and direct it over the top (stub axle/pivot point) of the front axle so that the wire is not pinched or constricted.



Figure 24 Triangular markings on the 12V wheel sensor.



Figure 25 Steering angle sensor on New Holland.



Figure 26 Stub axle with grease nipple.



### 5.2.2 Mounting the sensor disc

1. Mount the sensor disc without spacers on the provided 20x3 strip (Figure 27).
2. Mount the sensor disc in the sensor housing and mark where the first bend should be made (about 10 cm from the beginning). The first bend should be as close as possible to the sensor disc and be positioned as tight as possible against the stub axle housing to prevent damage by crops or soil (Figure 27 and Figure 28). The most extreme wheel position is usually the tightest position of the strip. Do not bend the strip too sharply.
3. Mark the position of the second bend in the strip until the sensor disc fits nice and flat in the sensor housing. On the other side, the strip must rest just underneath and against the front axle. The strip should rest on the sensor housing. Cut the strip to the correct length.
4. The wheel angle sensor strip should now be mounted to the bottom of the front axle (Figure 28). Mark the location of the holes on the strip and drill two 5 mm holes in the strip at approximately 30 mm apart.
5. Hold the strip with disc in the correct position and drill the first hole in the front axle with a 5 mm drill bit (about 10-15 mm deep). Drill into the thickest part of the front axle. Not too deep!



Figure 27 Disc on the strip without spacers.



Figure 28 Strip with second bend and shortened.



#### Caution!

Ensure that the hole does not wear out when drilling (drill clean and straight). When drilling, ensure that the strip is under tension when positioned against the sensor housing so as to prevent the strip from vibrating. So, drill slightly higher!



6. Tap the first thread in the hole drilled into the front axle using a M6 screw-thread tapping attachment. Now fasten the strip with one M6 bolt (Figure 29).
7. Drill the second hole in the front axle with a 5 mm drill bit. Remove the strip again and tap the second screw thread in the hole in the front axle.
8. Drill the second hole in the wheel angle sensor strip with 6 mm drill bit. Fasten the strip with two M6 bolts.
9. Make sure the sensor disc falls nice and flat into the sensor housing and the strip also lies flat and under tension on both sides of the disc positioned against the sensor housing. Press with your thumb against the end of the strip and check if the strip bounces back easily without friction (Figure 35 and Figure 36). The sensor disc may only have a little bit of friction in the sensor housing.
10. If necessary, bend the strip a little bit. Two Bahco's are useful tools to do this (Figure 30).
11. Remove the strip again and mount the sensor disc on the bottom of the strip (Figure 31).
12. Mount the strip again with two M6 bolts on the front axle.
13. Check if the sensor disc is properly centered with the sensor housing. The strip has to lie flat under slight pretention against the sensor housing (Figure 31). Also turn the wheels to make sure the sensor housing remains properly centered in various wheel positions.

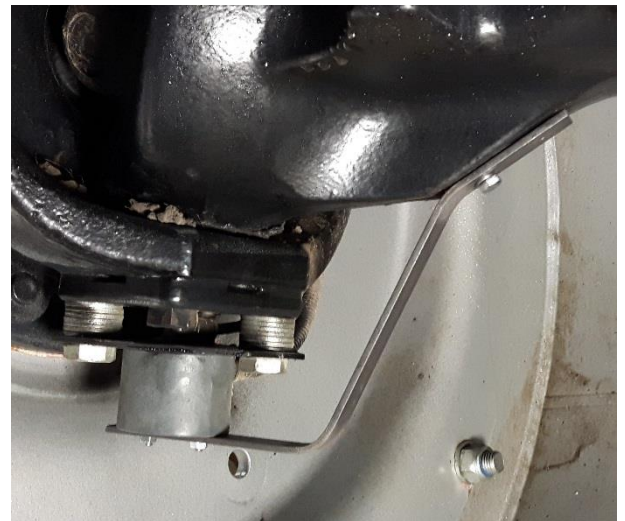

Figure 29 Strip on the front axle with one bolt.



Figure 30 Bend the strip with the help of two Bahco's.

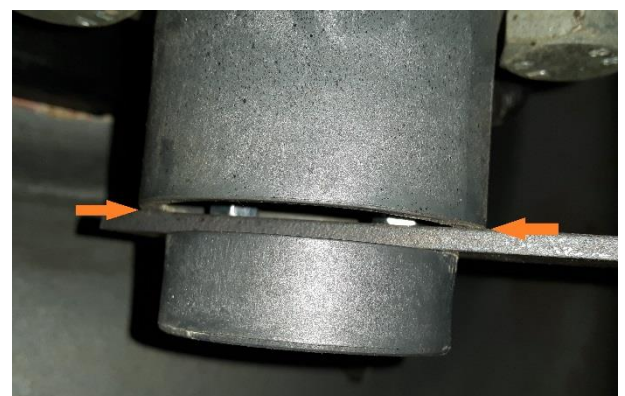

Figure 31 Disc at the other side of the strip.



14. Remove the strip again from the front axle. Then mount the strip again to the front axle with the aid of M5 X 30 bolts, raised with two nuts and two washers on each side. Mount on the proper side of the strip (Figure 32) and pay attention to the orientation of the disc (Figure 24). The triangular marker must be on the correct side.
15. Make sure the sensor magnet (Figure 33) in the sensor disc is completely clean (no iron fillings) before being mounted. Clean the sensor magnet with compressed air if necessary (Figure 34). Mount the strip back on the front axle.
16. Check again if the sensor disc lies under slight pretention against the sensor housing (Figure 35). Push with your thumb to the end of the wheel angle sensor strip to check this. The sensor disc may only have a little bit of friction in the sensor housing. The sensor disc should bounce back easily and without friction (Figure 36).



**Caution!**

*The sensor disc should be in a fully centered position within the sensor housing. The strip should be able to flex in a downward direction.*



**Figure 32** Wheel angle sensor disc mounted with spacers.



**Figure 33** Dirty wheel angle sensor magnet.



**Figure 34** Cleaning wheel angle sensor magnet.

**i** **Tip!:**  
*It is often useful to drill bigger holes (slots) in the wheel angle sensor strip for the sensor disc. Allow the nuts to be loose-fit when mounting the strip. The disc then centers itself automatically. Do not forget to tighten the nuts again.*

**!** **Caution!:**  
*Make sure the magnet of the wheel angle sensor is completely clean (no iron fillings) before mounting it. Cleaning the wheel angle sensor magnet with compressed air can prevent problems.*

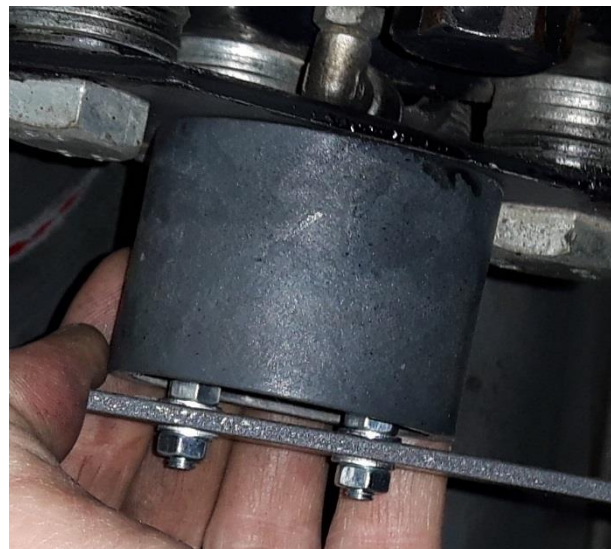

Figure 35 Centre and friction check of wheel angle sensor.

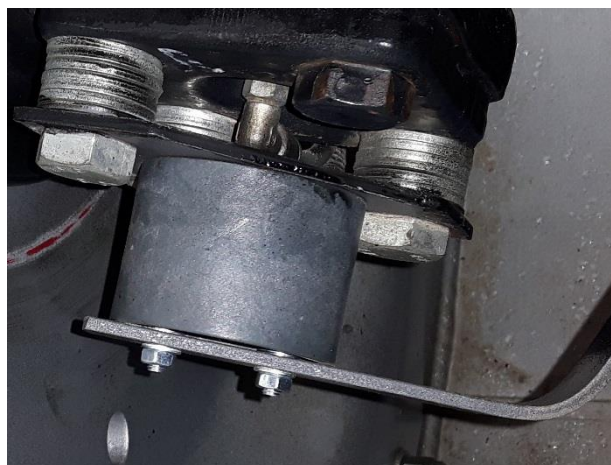

Figure 36 Correct mounted wheel angle sensor.



### 5.3 Heavy-duty Carraro front axle with independent suspension

Tractors with the heaviest type of Carraro front axle with independent suspension must be fitted with a special wheel angle sensor bracket (Figure 37). This type of assembly requires a wheel angle sensor with a much wider range (180°) in connection with the larger wheel turn (blue coloured wheel angle sensor). The wheel angle sensor should be mounted at the right sight behind the front axle of the tractor (Figure 37).

Required parts:

- 180° wheel angle sensor
- Wheel angle sensor bracket
- M8 threaded stub with nuts
- 2x M8 ball joint
- Carraro front axle wheel angle sensor bracket
- Carraro front axle tie rod bracket

Method of mounting:

- Install the wheel angle sensor to the bracket.
- Mount the bracket to the front axle.
- Set the arm of the sensor approximately 20 degrees off center (Figure 38). This means that the ball and socket joint of the wheel angle sensor are flush with the ball joint of the control rod. This in order to prevent, when fully to the left, the arm of the sensor and the threaded rod with the ball joints scissors with each other.
- Cut the threaded rod to measure. The ball joints are center to center 180mm long. Fit the clamp to the tie rod and the threaded rod with ball joints.
- After mounting check the mechanism by steering fully left and right.



**Figure 37 Carraro front axle.**

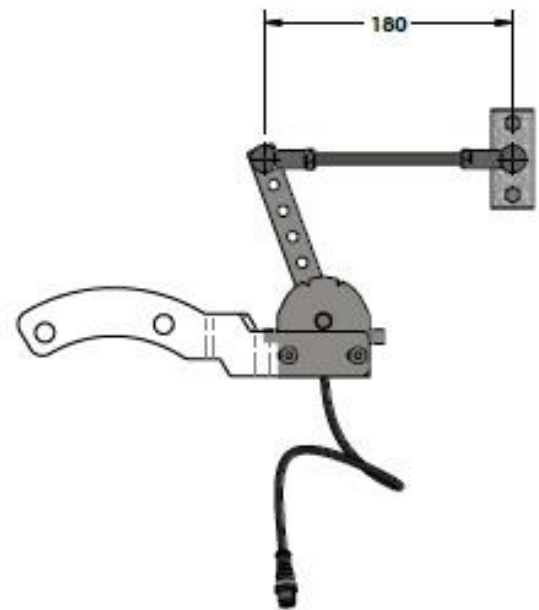

**Figure 38 Sensor with brackets.**

## 6. Mounting GPS and radio/gsm antenna

For receiving GPS satellites, a GPS antenna should be mounted (Figure 39 and Figure 40). Different antennas are available for receiving RTK corrections. Which antenna has to be mounted, is depending on the type of modem of the GPS terminal.

When using a built-in radio modem, a radio-antenna should be mounted. With a Slingshot modem, two GPRS / UMTS antennas and a GPS patch antenna should be mounted.

When all types of modems are used, all the antennas of above has to be mounted.

Label all the antenna cables with the correct label. This makes it easier for the operator, to connect the antennas to the correct connections on the modem and GPS terminal.



Figure 39 Septentrio GPS-antenna.

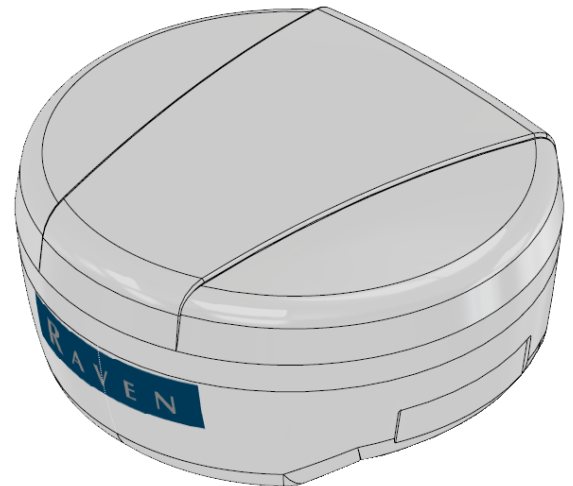

Figure 40 Raven 600S GPS-antenna.



## 6.1 Mounting the standard GPS antenna bracket

Figure 41 shows an example of the structure of standard GPS antenna equipment, which consists of a standard GPS antenna bracket, a GPS dummy and an UNC bolt + nut. The standard GPS antenna bracket can be taped to the cab roof using double-sided adhesive tape.

The following guidelines must be observed when installing the GPS antenna:

- The GPS antenna must be mounted at least 60 cm in front of the rear axle.
- Mount the GPS antenna in the centre of the tractor.
- Mount the GPS antenna using the UNC bolt included.
- Fasten the TNC-dummy to the GPS antenna bracket.
- Wire the antenna cable connector with the largest connector through to the inside of the cabin.
- Fasten the antenna cable so that it cannot become pinched anywhere and conceal inside the cabin upholstery, together with the GPS patch antenna cable, radio antenna cable or UMTS antenna cable.
- Mount the antenna cable in such a way that no water is allowed to flow along the cable into the cabin.
- Label the antenna cable inside the cabin with label 'GPS1'.



Figure 41 Standard GPS-antenna bracket with UNC nut and bolt and TNC-dummy.

## 6.2 Mounting of brand-dependent GPS antenna bracket

If appropriate and available (check availability at SBG!) a specific brand of GPS antenna bracket can be used. The same guidelines as described in section 6.1 apply to the installation.

## 6.3 Mounting one's own design of GPS antenna bracket

When there is no brand-specific GPS antenna bracket available, and the mounting bracket of a standard GPS antenna bracket is not possible, you can design your own. For your own design, apply broadly the same guidelines as for a standard GPS antenna bracket (Section 6.1), with a number of additions:

- Always mount the GPS antenna on the UNC bolt (hole: Ø 16 mm) included.
- Mount the TNC dummy at all times (hole: Ø 9 mm).
- Optionally support the GPS antenna bracket with the aid of a vibration damper.



#### 6.4 Mounting Raven 600S antenna

Nowadays, it is also possible to use SBGuidance Auto in combination with a Raven 600S antenna (Figure 42).

In this manual the installation of the 600S antenna is explained. For the configuration of this antenna see the English configuration manual: '016-8000-025EN-A - Configuration manual – 600S smart antenna'.

On the bottom side of the 600S antenna, two magnets are built-in for attaching the antenna to steel surfaces. The new version of the GPS antenna bracket has a slope on both sides, so that the 600S antenna is well centred on the GPS antenna bracket (Figure 42). The GPS antenna bracket has to be mounted on the front of the cabin roof.

See Figure 55 for the connection schematics of the 600S cabling. An adapter/split cable is supplied with this antenna. The antenna is connected through this adapter cable and the '600S to Viper 4' cable to the terminal harness. The adapter cable should remain to the GPS antenna when it is removed from the tractor.

If also a Slingshot modem is used for RTK corrections, a 'modem to receiver' cable has to be connected. Make sure that the connectors on the roof are provided with protective caps (Figure 44). With these protective caps no dust and water can enter the connectors.

Furthermore, the following guidelines must be observed when installing the GPS antenna:

- Mount the GPS-antenna with the connectors backwards (Figure 43).
- Mount the GPS-antenna at least 60 centimetres in front of the rear axle.

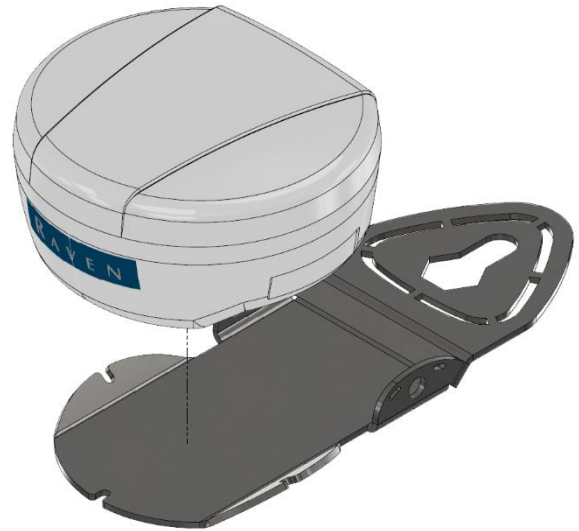

**Figure 42 Raven 600S antenne.**



**Figure 43 Raven 600S antenna on a cabin.**



**Figure 44 Cables to the Raven 600S antenna.**



### 6.5 Mounting the radio antenna

Figure 45 shows the standard radio antenna with magnetic base. Preferably, this standard antenna should be used. The components of this standard antenna are shown in Table 2.

**Table 2 Standard parts for radio antenna.**

Symbol	Description
1	Radio antenna
2	Antenna cable
3	Magnetic base

A number of specific conditions should be met before mounting the radio antenna:

- Preferably mount the radio antenna with the magnetic base on the standard GPS antenna bracket (Figure 41).
- Do not mount the radio antenna next to a steel construction, but above it.
- Mount magnetic base on a sufficiently large steel surface (at least the size of the standard GPS antenna bracket). A larger steel base surface can improve signal strength and prevent problems, especially at greater distances (> 9 km).
- Label the antenna cable inside the cabin with label 'Radio'.



**Figure 45 Components radio antenna.**



## 6.6 Mounting the GPRS/UMTS antenna

If a SlingShot modem is used, in addition to the GPS-antenna, two GPRS / UMTS antennas and a GPS patch should be mounted.

The GPRS / UMTS-antennas should be mounted at least 100 cm of each other (like the CNH antenna-bracket in Figure 47). If a standard GPS-antenna bracket is mounted, one of the GPRS / UMTS-antennas should be mounted on this bracket (Figure 46). The second GPRS / UMTS-antenna should be mounted on a metal bracket on the cabin (Figure 48).

It is important that the following conditions are met at all times:

- The GPRS/UMTS antenna is equipped with a magnetic base and must be placed on top of the cabin.
- The antenna should have a clear reception all round.
- Label the antenna cables inside the cabin with labels 'Cellular' and 'Diversity' (Figure 49).
- Mount a grey SMA grip on both connectors (Figure 49).



**Figure 46** GPS antenna bracket with a Laird UMTS antenna.



**Figure 47** Case New Holland with GPS-antenna, GPS patch antenna and two GPRS/UMTS antenna's.



**Figure 48** GPRS/UMTS-antenna and GPS patch antenna on a metal bracket.

### 6.7 Mounting GPS Patch antenna

When using a SlingShot modem also a GPS Patch antenna should be mounted (Figure 48). The GPS Patch antenna is magnetic. Mount the GPS Patch antenna always on the roof of the cabin. Be careful with mounting the GPS patch antenna; the GPS patch antenna cable is quite thin and fragile. Label the GPS Patch antenna cable inside the cabin with label 'GPS' and mount a blue SMA grip to the connector (Figure 49).



Figure 49 Antenna cables with labels and SMA-grip set.



Intentionally left blank.

## 7. Mounting DynamIQ ISO

The following guidelines have been established for mounting the DynamIQ ISO:

- Preferably, place the DynamIQ ISO next to and to the right of the seat. Use the standard DynamIQ ISO mounting bracket.
- If it is not possible to attach the DynamIQ ISO to the seat bolts, the DynamIQ ISO should be attached in an appropriate place in the cabin that is free from vibrations.
- A DynamIQ ISO may only be mounted in a horizontal position (with the sticker side up). The connectors may be orientated in four directions (0, 90, 180, 270 degrees).
- By default, the orientation of the DynamIQ ISO is set to: horizontal position with connectors pointing towards the rear (as shown in Figure 50). Any other orientation should be set in the software!



Figure 50 DynamIQ ISO mounted next to the seat.



Intentionally left blank.

## 8. Mounting the terminal

The following guidelines have been established for mounting the terminal (Figure 51):

- Always contact the customer about the terminal position in the cabin.
- Always use a RAM-D or RAM-C ball attachment.
- Mount the terminal free of vibrations with a solid bracket. A variety of mounting brackets are available for this purpose.
- Conceal all cables in one pillar (e.g. A-pillar or B-pillar).
- Mount in such a way that the display is directed straight towards the driver.
- Mount in such a way that driver has a clear view all around.



### Tip!:

Mount the terminal in such a way that it does not obstruct the view of the driver over the top of the right-hand fender, but also so that the inside of the front wheel on the ground is still clearly visible.

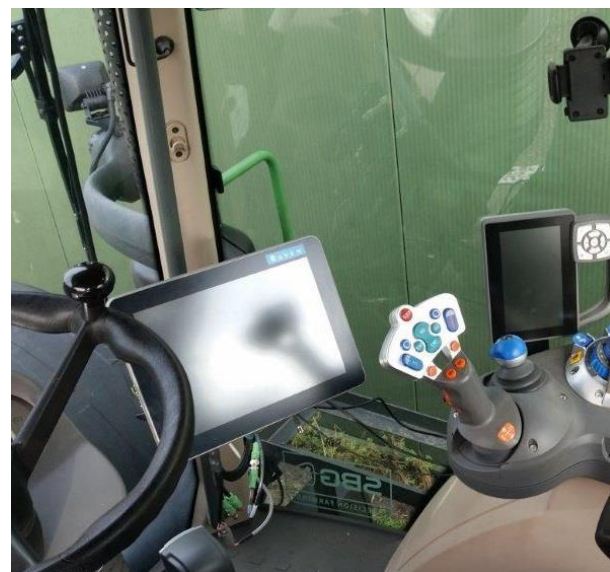

Figure 51 Viper 4+ mounted to A-pillar.



Figure 52 GeoStar terminal mounted to ISO attachment of A-pillar.



Intentionally left blank.



## 9. Annexes

### 9.1 Pin-out Steering Controller

Table 3 STU B-connector (black)

Pin	Description	Colour
1	VCC / PWM	Black
2	Actuator ground	Black
3	Shut-off valve	Black
4	Pressure sensor (12V)	Black
5	Pressure sensor signal	Green/yellow
6	Wheel angle sensor power (+5V)	Black
7	Wheel angle sensor signal	Black
8	N.C.	N.C.
9	Wheel angle sensor power (+12V)	Black
10	ECU ground	Green/yellow
11	Actuator ground	Green/yellow
12	VCC / PWM	Black

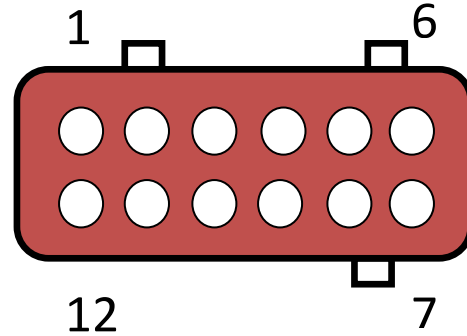
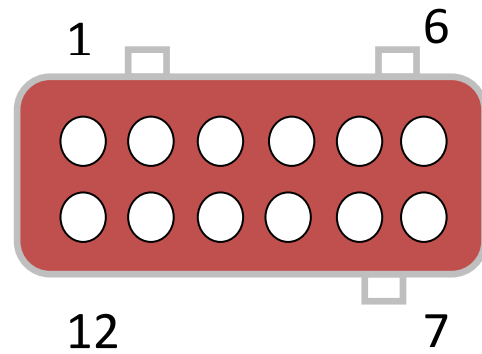

Table 4 STU A-connector (grey)

Pin	Description	Colour
1	Actuator power	Red
2	Actuator power	Red
3	ECU power	Red
4	N.C.	N.C.
5	N.C.	N.C.
6	CAN High	Yellow
7	CAN Low	Green
8	N.C.	N.C.
9	N.C.	N.C.
10	ECU ground	Black
11	Actuator ground	Black
12	Actuator ground	Black





9.2 Schematic overview of system

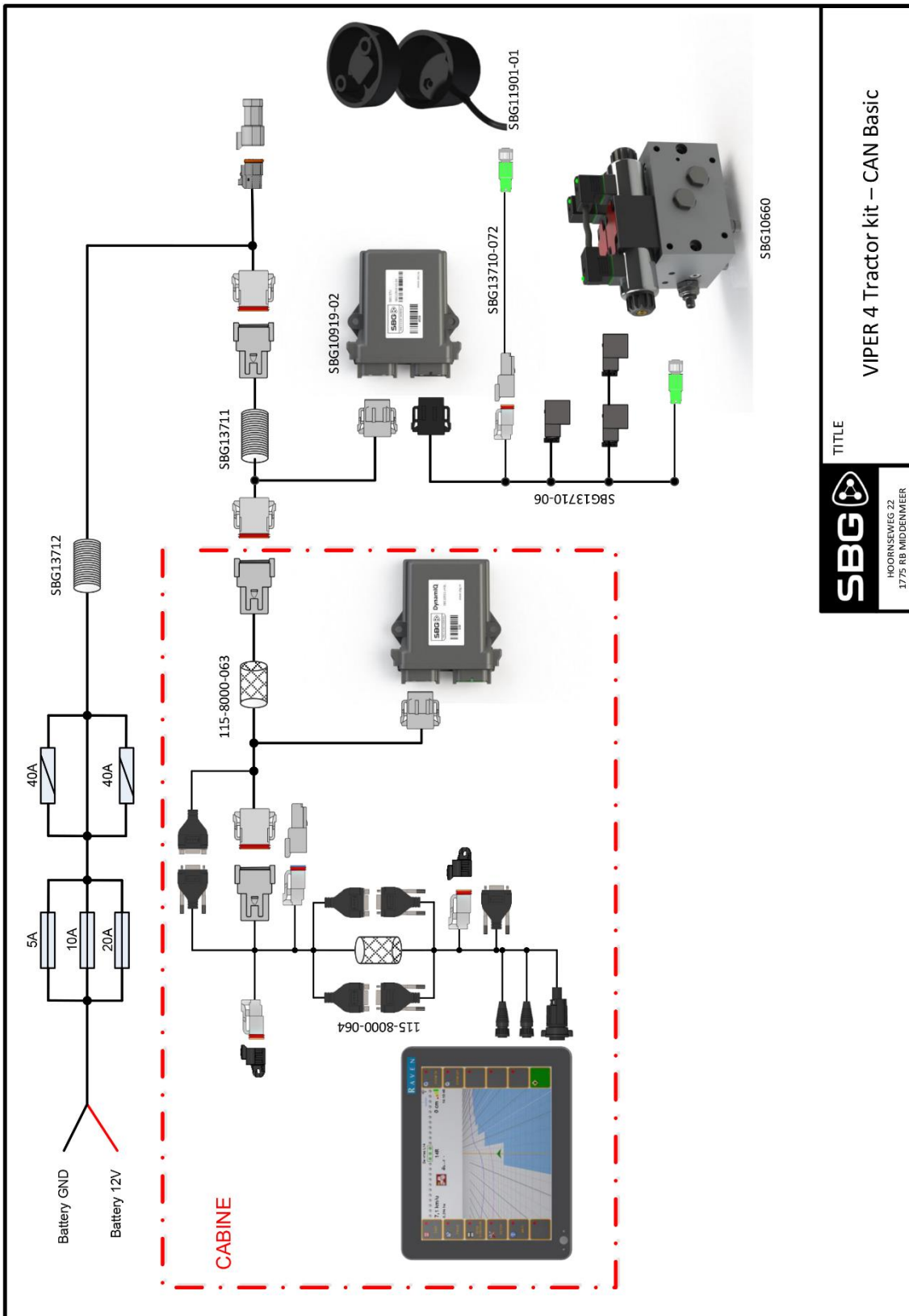

TITLE

**SBG**

HOORNSEWEG 22  
1775 RB MIDDENMEER

VIPER 4 Tractor kit – CAN Basic

Figure 53 System overview with Basic Power Harness.

9.3 Systematic overview Implement ready

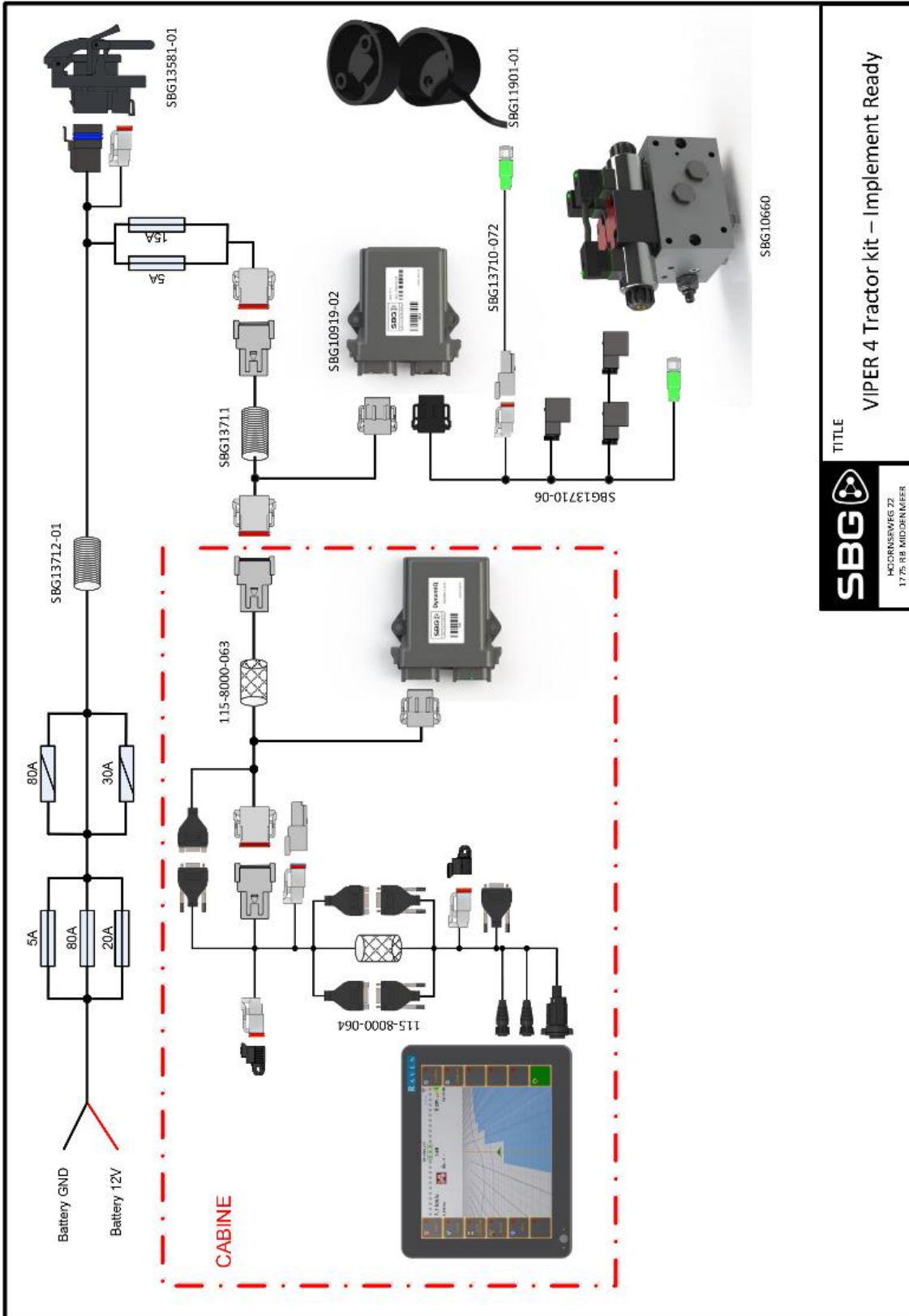

TITLE  
VIPER 4 Tractor kit – Implement Ready

**SBG**  
HOORNSEWEG 22  
1775 RB MIDDENMEER

Figure 54 System overview Implement Ready.



9.4 Mounting 600S GPS-antenna

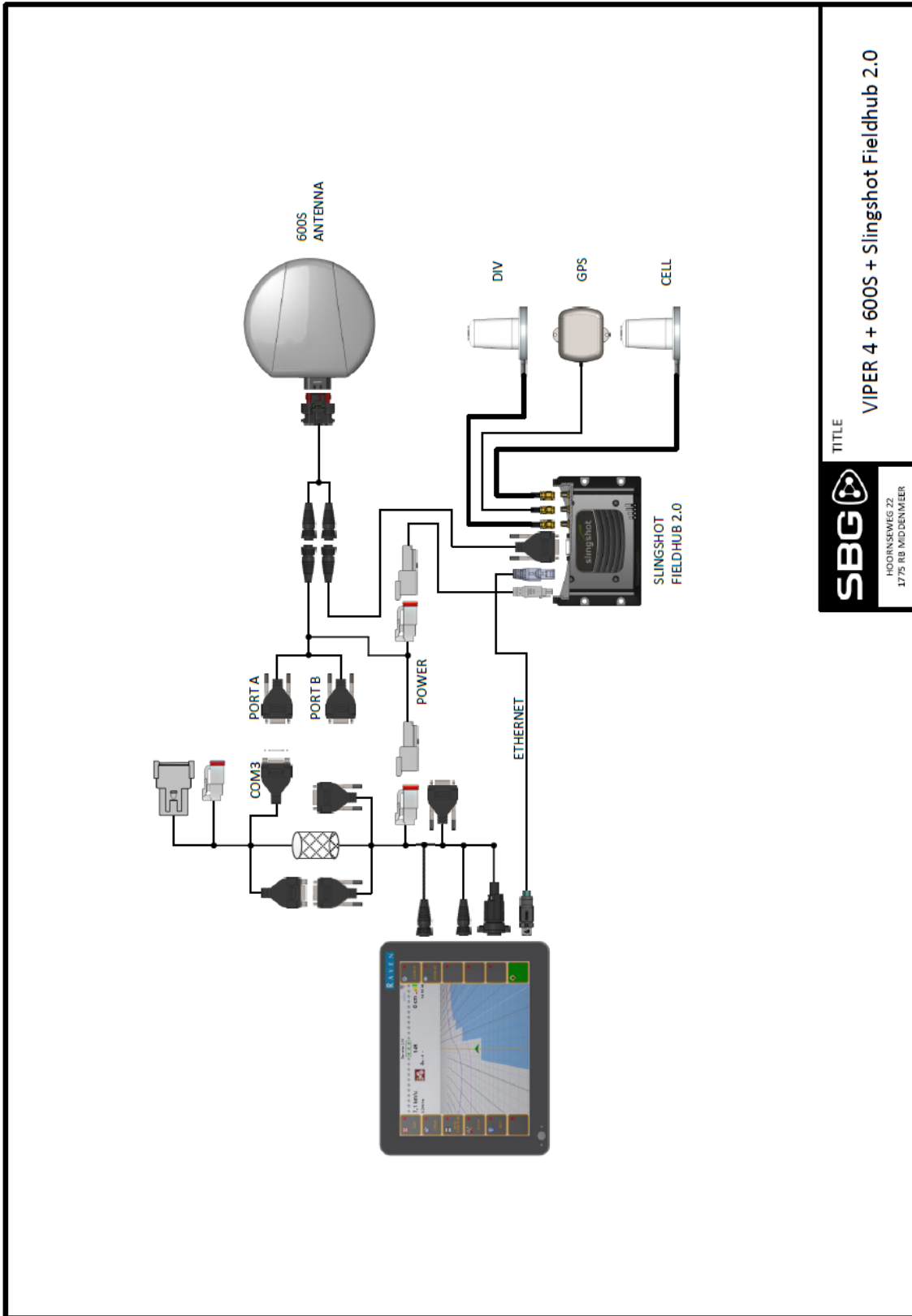

TITLE  
VIPER 4 + 600S + Slingshot Fieldhub 2.0

**SBG**  
HOORNSEWEG 22  
1775 RB MIDDENMEER

Figure 55 Mounting 600S antenna.